



2013 
DODGE CHALLENGER



CHALLENGER R/T CLASSIC SHOWN IN BILLET SILVER METALLIC.

BORN OF MUSCLE AND RAISED ON TECHNOLOGY, THIS IS THE STUFF OF LEGENDS. IT ARRIVES WITH THE DNA OF ITS LEGENDARY FOREFATHER, 21ST-CENTURY MECHANICS, AND MODERN COMFORTS. INTENSE HANDLING DYNAMICS AND LEADING-EDGE COMPONENTS TRANSFER HARDCORE POWER TO THE ROAD, EARNING IT SERIOUS STREET RESPECT. SCULPTED WITH A LEAN, LOW PROFILE AND MENACING THROWBACK STYLE, THERE IS NO DOUBT WHO AND WHERE IT CAME FROM. THIS UNMISTAKABLE ICON IS THE 2013 DODGE CHALLENGER.

HERITAGE-INSPIRED STYLING // INTIMIDATING MUSCLE CAR RUMBLE // UNMATCHED PERSONALIZATION OPTIONS WITH STRIPES, COLORS, AND WHEELS // NEW RALLYE REDLINE AND BLACKTOP PACKAGES // 305-HORSEPOWER AWARD-WINNING 3.6L DOHC PENTASTAR® VARIABLE VALVE TIMING (VVT) V6 ENGINE DELIVERING 27 MPG HIGHWAY* // AVAILABLE 375-HORSEPOWER HEMI® V8 // AVAILABLE DIE-CAST STEERING WHEEL-MOUNTED PADDLE SHIFTERS // CLASS-EXCLUSIVE^{(1)†} FIVE-PASSENGER SEATING // 2012 POLK AUTOMOTIVE LOYALTY AWARD WINNER // CARS.COM 2012 SHOPPERS' CHOICE AWARD WINNER // 2012 *CONSUMERS DIGEST* BEST BUY AWARD WINNER // J.D. POWER APEAL AWARD

*BASED ON EPA ESTIMATED 18 CITY/27 HWY MPG.

†A NOTE ABOUT THIS BROCHURE: ALL DISCLAIMERS AND DISCLOSURES CAN BE FOUND ON THE LAST PAGE.



Challenger



POWER IS NOTHING
WITHOUT CONTROL

CHALLENGER R/T CLASSIC SHOWN IN BILLET SILVER METALLIC WITH 20-INCH ALUMINUM WHEELS.



RAW POWER IS ONE THING. HAVING THE CHOPS TO BACK IT UP IS ANOTHER. CHALLENGER'S AVAILABLE COMBINED PERFORMANCE FEATURES STAND AS A UNITED FRONT TO BRING DRIVERS THE BEST COMBINATION OF MOVEMENT AND CONTROL. CHALLENGER'S SUSPENSION GEOMETRY WORKS TOGETHER WITH REAR-WHEEL DRIVE TO OFFER AN IMPRESSIVE RIDE AND PRECISE HANDLING ACROSS A DYNAMIC RANGE. THE CLASS-EXCLUSIVE^[1] INDEPENDENT FIVE-LINK REAR SUSPENSION IS TUNED TO PROVIDE A COMFORTABLE RIDE AND SUPERIOR HANDLING, THANKS TO LOWER UNSPRUNG MASS, WHICH HELPS MAINTAIN BETTER TIRE CONTACT WITH THE GROUND AND REDUCES REAR ROAD NOISE. THE ELECTRONIC STABILITY CONTROL (ESC)^[2] SYSTEM MONITORS STEERING INPUT AND VEHICLE MOTION TO HELP KEEP THE DRIVER IN COMMAND OF THE VEHICLE. THE SYSTEM AUTOMATICALLY SENSES WHEEL SLIPPAGE AND RESPONDS IMMEDIATELY TO HELP REGAIN CONTROL. THE STANDARD FOUR-WHEEL DISC BRAKES BRING SUBSTANTIAL BRAKING POWER WITH ANTILOCK AND BRAKE ASSIST. OR IN OTHER WORDS, IT'S ENGINEERING THAT HELPS YOU STOP ON A DIME.



375 HP

25 HWY MPG*

AVAILABLE 5.7-LITER HEMI® V8 VARIABLE VALVE TIMING (VVT) ENGINE. IT STARTS WITH A LEGENDARY NAMEPLATE UNDERFOOT — HEMI V8 — DELIVERING 0–60 MPH IN THE LOW FIVE-SECOND RANGE, AN INTOXICATING EXHAUST NOTE, AND RESPONSIVE DRIVING DYNAMICS. ADD IN FUEL SAVER TECHNOLOGY† AND VVT TO GIVE THIS ENGINE STUNNING POWER AND EFFICIENCY CREDENTIALS. THE 5.7-LITER HEMI V8 BOASTS 375 HORSEPOWER AND A WHOPPING 410 LB-FT OF TORQUE WHEN EQUIPPED WITH THE SIX-SPEED CLOSE RATIO MANUAL TRANSMISSION, AND 372 HORSEPOWER AND 400 LB-FT OF TORQUE WHEN PAIRED WITH THE AVAILABLE FIVE-SPEED AUTOMATIC TRANSMISSION WITH PADDLE SHIFTERS AND AUTOSTICK. WHEN EQUIPPED WITH FUEL SAVER TECHNOLOGY,‡ THE COMPUTER USES SOPHISTICATED ALGORITHMS TO SEAMLESSLY TRANSITION FROM EIGHT CYLINDERS TO FOUR CYLINDERS WHEN FULL POWER IS NOT REQUIRED, HELPING TO PROVIDE INCREASED FUEL ECONOMY OF 25 HIGHWAY MPG.*

*BASED ON EPA ESTIMATED 16 CITY/25 HIGHWAY MPG WITH FIVE-SPEED AUTOMATIC TRANSMISSION.

† WHEN EQUIPPED WITH FIVE-SPEED AUTOMATIC TRANSMISSION.

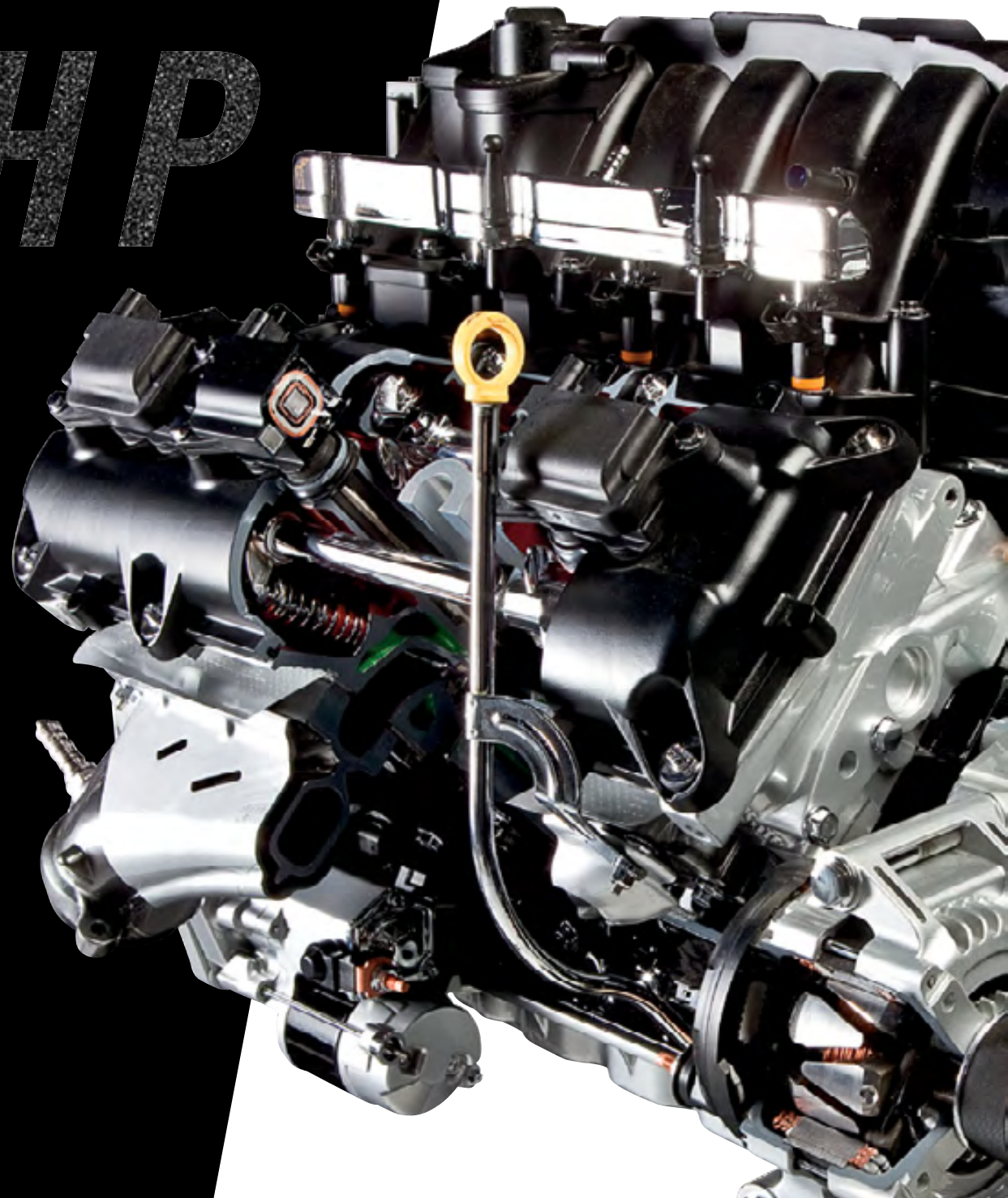



305 HORSEPOWER 27 HWY MPG[‡]

3.6L DOHC PENTASTAR[®] VVT V6 ENGINE. FROM A HIGH-PRESSURE DIE-CAST ALUMINUM BLOCK TO FULLY INDEPENDENT DUAL-CAM PHASING, SEQUENTIAL PORT FUEL INJECTION, AND HIGH-FLOW INTAKE AND EXHAUST PORTS, THIS POWERHOUSE APPLIES SOME OF THE MOST ADVANCED AUTOMOTIVE ENGINE TECHNOLOGY. THE RESULT IS AN EXCEPTIONAL BLEND OF HIGH TORQUE, FUEL EFFICIENCY, LOW EMISSIONS, AND FIRST-RATE NOISE, VIBRATION, AND HARSHNESS (NVH) CONTROL. THE ONLY THING BETTER THAN NUMBERS LIKE 305 HORSEPOWER AND 268 LB-FT OF TORQUE WITH AN EPA ESTIMATED FUEL ECONOMY OF 27 HIGHWAY MPG[‡] IS THE ENGINE'S DURABILITY-ENHANCING FEATURES — LIKE AN ADVANCED OIL FILTER SYSTEM THAT HELPS TO ELIMINATE OIL SPILLS AND CONTAINS AN INCINERABLE FILTER ELEMENT FOR MORE EFFICIENT DISPOSAL.

‡BASED ON EPA ESTIMATED 18 CITY/27 HIGHWAY MPG.



SRT[®] HEMI[®] V8

392-CUBIC-INCH SRT HEMI V8 ENGINE WITH 470 HORSEPOWER. IT GEARS UP WITH AN ACTIVE INTAKE MANIFOLD AND HIGH-LIFT CAMSHAFT WITH CAM PHASING, PROVIDING MAXIMUM LOW-END TORQUE AND HIGH-END POWER FOR A REMARKABLE 470 HORSEPOWER AND 470 LB-FT OF TORQUE. WITH AN IMPRESSIVELY FLAT TORQUE CURVE, THE SRT HEMI V8 DELIVERS MOMENTOUS POWER FOR STRONG STANDING STARTS AND PASSING MANEUVERS. MODELS EQUIPPED WITH THE AUTOMATIC TRANSMISSION RECEIVE FUEL SAVER TECHNOLOGY THAT ALLOWS THE ENGINE TO DEACTIVATE FOUR CYLINDERS WHEN EIGHT ARE NOT NEEDED, CREATING THE PERFECT FORMULA OF POWER, EFFICIENCY, AND WISE CONSUMPTION.



CHALLENGER SRT® 392 SHOWN IN JAZZ BLUE PEARL.

A large, stylized white 'SRT' logo is positioned vertically on the left side of the page, set against a solid black background. The letters are bold and blocky, with a slight shadow effect.

*BANKING ON ITS HIGH-
PERFORMANCE BIRTHRIGHT.*



THERE'S STREET CRED AND THERE'S TRACK CRED. CHALLENGER SRT® HAS SERIOUS CREDENTIALS IN BOTH. IT WAS BORN TO PERFORM AND COMES TO THE TABLE WITH A 0-60 MPH TIME IN THE HIGH FOUR-SECOND RANGE, REACHES A TOP SPEED OF 182 MPH WITH THE MANUAL TRANSMISSION, AND STRIKES WITH A 470-HORSEPOWER 392-CUBIC-INCH SRT HEMI® V8, A SOPHISTICATED THREE-MODE ADAPTIVE DAMPING SUSPENSION (WITH AUTO, SPORT, AND TRACK MODES), LAUNCH CONTROL, AND 20-INCH FORGED POLISHED ALUMINUM WHEELS WITH BLACK POCKETS. AVAILABLE IN A VARIETY OF EXTERIOR COLORS AND SRT DUAL CENTER STRIPES IN SILVER HIGH GLOSS, BLACK HIGH GLOSS, RED HIGH GLOSS, AND MEDIUM GRAY METALLIC HIGH GLOSS. IT HAS A BRIGHT GRILLE SURROUND AND A BOLD "392 HEMI" BADGE THAT GRACES THE FENDERS AND IS EMBOSSED ON THE ENGINE VALVE COVERS. THE 18-SPEAKER HARMAN KARDON® AUDIO GROUP IS ALSO AVAILABLE. HIT DRIVESRT.COM FOR THE FULL DETAILS.



RETRO DONE RIGHT. INFLUENCED BY MORE THAN 40 YEARS OF INTERIOR DESIGN AND INNOVATION, CHALLENGER'S "FOUR BOMB" TUNNEL-STYLE GAUGES AND AVAILABLE RACE-INSPIRED PEDALS NOD TO THE ORIGINAL. A THICK-RIMMED LEATHER-WRAPPED THREE-SPOKE STEERING WHEEL FEATURES INTEGRATED AUDIO AND CRUISE CONTROLS. MODELS WITH A FIVE-SPEED AUTOMATIC TRANSMISSION FEATURE AVAILABLE PERFORMANCE-INSPIRED DIE-CAST STEERING WHEEL-MOUNTED PADDLE SHIFTERS. KEEP THE TUNES TIGHT WITH THE AVAILABLE HARMAN KARDON® AUDIO GROUP, FEATURING 18 PREMIUM HIGH-PERFORMANCE SPEAKERS AND A 900-WATT DIGITAL AMPLIFIER. DEPENDING ON MODEL, CHALLENGER OFFERS PREMIUM CLOTH OR HEATED NAPPA LEATHER-TRIMMED SEATS AND A SIX-WAY POWER DRIVER'S SEAT. WITH MORE INTERIOR VOLUME THAN FORD MUSTANG OR CHEVY CAMARO,^[1] EVERYONE CAN SPREAD OUT. THE REAR DELIVERS SERIOUS SPACE WITH A STANDARD FOLD-DOWN CENTER ARMREST WITH CUP HOLDERS AND SEATING FOR THREE PASSENGERS, MAKING IT THE ONLY VEHICLE IN ITS CLASS TO OFFER FIVE-PASSENGER SEATING.^[1] THE 60/40 SPLIT-FOLDING REAR SEATS WITH TRUNK ACCESS EASILY ACCOMMODATE LARGER ITEMS AND PROVIDE ENTRY TO THE BEST-IN-CLASS^[1] REAR CARGO STORAGE VOLUME.

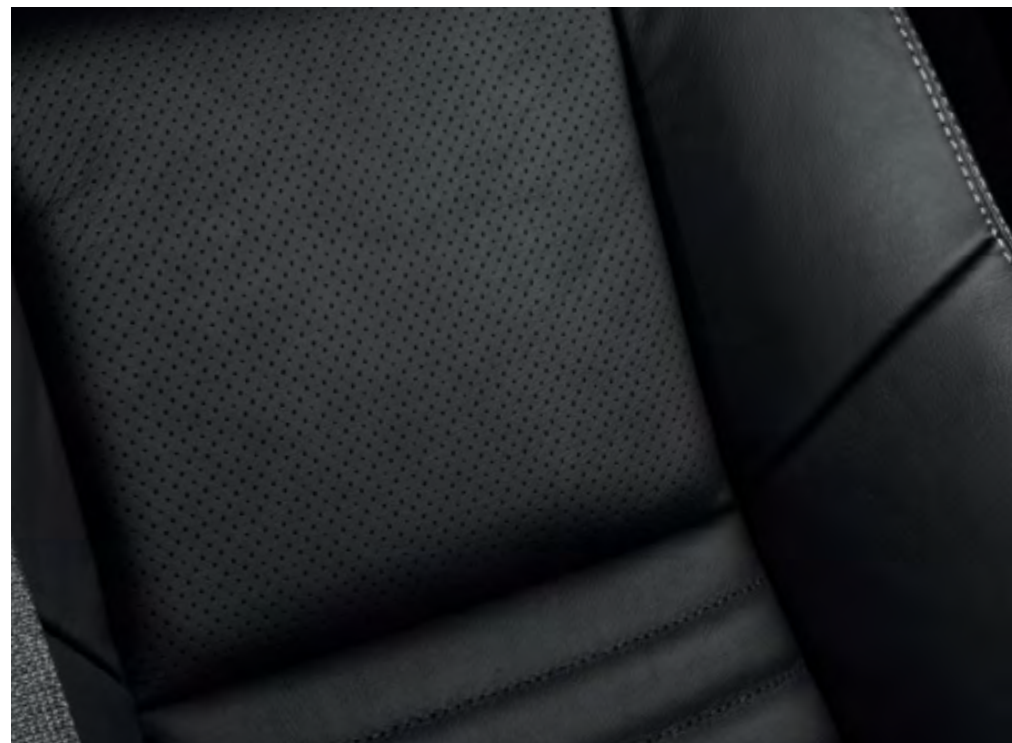



CHALLENGER R/T PLUS SHOWN WITH DARK SLATE GRAY LEATHER-TRIMMED SEATS AND FIVE-SPEED AUTOSTICK.



RALLYE REDLINE PACKAGE SHOWN IN PITCH BLACK.



RALLYE REDLINE. WHAT'S DIFFERENT ABOUT THIS CHALLENGER? FOR STARTERS, IT MIGHT BE AS CLOSE AS A PRODUCTION CAR GETS TO LOOKING COMPLETELY CUSTOM. USING CHALLENGER SXT PLUS AS ITS FOUNDATION, RALLYE REDLINE OFFERS ITSELF IN FOUR MENACING COLORS: BILLET SILVER METALLIC, GRANITE CRYSTAL METALLIC, BRIGHT WHITE, OR PITCH BLACK. A UNIQUE THICK REDLINE RED HOOD-TO-TAIL RACING STRIPE, DISTINCTIVE 20-INCH BLACK CHROME ALUMINUM WHEELS WITH RED LIP AND BACKBONE, P245/45ZR20 BSW ALL-SEASON PERFORMANCE TIRES, REAR BODY-COLOR SPOILER, AND DUAL RECTANGULAR EXHAUST TIPS SET THE STANDARD FOR THE RACE-INSPIRED EXTERIOR. HEATED NAPPA LEATHER-TRIMMED SPORT SEATS IN DARK SLATE GRAY OR AVAILABLE RADAR RED GIVE THE COCKPIT AMPED-UP ATTITUDE. STEERING WHEEL-MOUNTED DIE-CAST PADDLE SHIFTERS AND SELECTABLE SPORT MODE OFFER THE DRIVER A MORE PERFORMANCE-ORIENTED FEEL. THE DASHBOARD IS SIMPLE, CLEAN, AND CLASSIC DODGE CHALLENGER. OTHER STANDARD FEATURES INCLUDE PARKSENSE® REAR PARK ASSIST,^[3] UCONNECT® VOICE COMMAND^[4] WITH BLUETOOTH® STREAMING AUDIO, AND A BOSTON ACOUSTICS® SIX-SPEAKER SOUND SYSTEM. RALLYE REDLINE'S HUSTLE COMES FROM THE 3.6-LITER PENTASTAR® V6 ENGINE. WITH 305 HORSEPOWER AND 268 LB-FT OF TORQUE, THIS CHALLENGER'S ACCELERATION IS FURTHER ENHANCED THANKS TO ITS 3.06 REAR AXLE RATIO.



CHALLENGER R/T CLASSIC.

CORPORAL STRIPES. MAJOR ATTITUDE.
STAND OUT AND BE NOTICED WITH
A SCRIPTED CHALLENGER FENDER
BADGE THAT PAYS HOMAGE TO THE
ORIGINAL, CLASSIC DUAL BODYSIDE
STRIPES, UNIQUE 20-INCH ALUMINUM
WHEELS, AND HIGH INTENSITY
DISCHARGE (HID) HEADLAMPS.



CHALLENGER R/T CLASSIC SHOWN IN HEMI ORANGE.*
*LATE AVAILABILITY.

STRIPE OPTIONS. IN THE GOLDEN AGE OF MUSCLE, THE ONLY THING BETTER THAN OWNING A MUSCLE CAR WAS OWNING ONE UNLIKE ANY OTHER. IN THAT SPIRIT, CHALLENGER OFFERS SEVERAL STRIPE OPTIONS, REMINISCENT OF THOSE FROM THE 1970S. CHECK OUT THE DETAILS BELOW.



R/T HOOD-TO-FENDER STRIPES



RALLYE REDLINE CENTER STRIPE



R/T CLASSIC DUAL BODYSIDE STRIPES



SRT® 392 DUAL CENTER STRIPES

**CHALLENGER
COLOR/STRIPE AVAILABILITY**

	R/T AND R/T PLUS HOOD-TO-FENDER STRIPES	RALLYE REDLINE CENTER STRIPE	R/T CLASSIC DUAL BODYSIDE STRIPES	SRT 392 DUAL CENTER STRIPES
JAZZ BLUE PEARL	●○		●○	●●●●
BILLET SILVER METALLIC	●●	●	●●	●●●●
BRIGHT WHITE	●●	●	●●	●●●●
PITCH BLACK	●●○	●	●●○	●●●
REDLINE TRI-COAT PEARL	●○		●○	●●●
GRANITE CRYSTAL METALLIC	●●●○	●	●●○	●●●●
PHANTOM BLACK TRI-COAT PEARL	●●○		●●○	●●●

● = Silver, ● = Black, ● = Red, ○ = White, ● = Gray



CHALLENGER SXT PLUS SHOWN IN PITCH BLACK WITH AVAILABLE 20-INCH CHROME-CLAD WHEELS.



WELL-CONNECTED

ENGINEERED WITH TECHNOLOGY, CHALLENGER AND UCONNECT® HELP KEEP YOU CLOSE TO YOUR FAVORITE PEOPLE, MUSIC, AND PLACES.

UCONNECT FEATURES EASY-TO-NAVIGATE ICONS FOR RADIO AND SIRIUSXM SATELLITE RADIO^[5] * CONTROLS, PERSONAL DEVICES SUCH AS AN IPOD® OR SMARTPHONE, CLIMATE CONTROLS, AND AVAILABLE NAVIGATION AND BLUETOOTH® COMPATIBLE PHONES. BRING ALONG YOUR OWN TUNES VIA REMOTE USB PORT WITH IPOD MOBILE DEVICE CONTROL OR BLUETOOTH WIRELESS STREAMING. THE USB PORT CAN ALSO CHARGE YOUR COMPATIBLE DEVICES.

WITH AVAILABLE VOICE COMMAND^[4] AND FRONT- AND REAR-MOUNTED STEERING WHEEL CONTROLS, THERE'S NO TAKING YOUR HANDS OFF THE WHEEL OR EYES OFF THE ROAD. GIVE VOICE COMMANDS FOR THINGS LIKE PHONE OPERATION, RADIO/CD FUNCTIONS, AND ACCESSING YOUR DIGITAL MEDIA PLAYERS.

OPT FOR GARMIN® NAVIGATION FOR TURN-BY-TURN DIRECTIONS, LANE GUIDANCE, OR LOCATING NEARBY RESTAURANTS, SHOPPING, HOSPITALS, OR LOCAL POINTS OF INTEREST. ADD AVAILABLE SIRIUSXM TRAFFIC^[5] * FOR COMPREHENSIVE TRAFFIC INFORMATION SENT DIRECTLY TO YOUR CHALLENGER. THIS INCLUDES UPDATED INFORMATION ON TRAFFIC SPEED AND FLOW, ACCIDENTS, CONSTRUCTION, AND ROAD CLOSURES. CHOOSE SIRIUSXM TRAVEL LINK^[5] TO BRING LOCAL AND NATIONAL WEATHER FORECASTS, FUEL PRICES FOR LOCAL GAS STATIONS, IN-GAME AND FINAL SPORTS SCORES, WEEKLY SPORTS SCHEDULES, AND LOCAL MOVIE THEATER LISTINGS RIGHT TO YOUR VEHICLE. FOR MORE INFORMATION GO TO DRIVEUCONNECT.COM *FIRST YEAR OF SERVICE IS INCLUDED.



5 YEAR / 100,000 MILE
POWERTRAIN WARRANTY[®]

OFFERING OVER 45 STANDARD AND AVAILABLE SAFETY AND SECURITY FEATURES, REASSURANCE IS ENGINEERED INTO EVERY CHALLENGER.

RAIN BRAKE SUPPORT. INVALUABLE IN WET CONDITIONS. WHEN THE WINDSHIELD WIPERS HAVE BEEN ACTIVATED, IT PULSES THE BRAKE PADS CLOSER TO THE SPINNING ROTOR — HELPING KEEP THE ROTORS AND PADS DRY FOR GREATER CONTROL AND OPERATOR SECURITY. **AIR BAGS.^[7]** ADVANCED MULTISTAGE FRONT AIR BAGS, SUPPLEMENTAL FRONT-SEAT SIDE-MOUNTED AIR BAGS, AND SUPPLEMENTAL SIDE-CURTAIN AIR BAGS FOR FRONT AND REAR OUTBOARD OCCUPANTS ARE ALL STANDARD. **TIRE PRESSURE MONITORING SYSTEM.** STANDARD PRESSURE SENSORS IN THE TIRE VALVES ALLOW FOR AUTOMATIC DETECTION AND NOTIFICATION WHEN TIRE PRESSURE IS LOW. **ACTIVE HEAD RESTRAINTS.^[8]** IN THE EVENT OF A REAR-END COLLISION, THE HEAD RESTRAINT MOVES FORWARD AND UPWARD TO DECREASE THE SPACE BETWEEN THE HEAD RESTRAINT AND THE OCCUPANT'S HEAD, THEREBY HELPING TO REDUCE THE CHANCE OF INJURY. **ELECTRONIC STABILITY CONTROL (ESC).^[2]** A STANDARD VEHICLE-WIDE NETWORK OF SAFETY SENSORS PROVIDES INSTANT AID WHEN THE SENSORS DETECT THAT YOU'RE VEERING OFF YOUR INTENDED PATH. THIS ROBUST SYSTEM INCLUDES ANTILOCK BRAKE SYSTEM (ABS) WITH BRAKE ASSIST AND ALL-SPEED TRACTION CONTROL. **IMPROVED CRUMPLE ZONES.** DESIGNED TO DIVERT AND DISSIPATE IMPACT ENERGY AWAY FROM THE PASSENGER COMPARTMENT, HELPING TO MINIMIZE INJURIES IN THE EVENT OF AN ACCIDENT. **SENTRY KEY[®] ENGINE IMMOBILIZER.** THE VEHICLE IS PREVENTED FROM STARTING UNLESS THE KEY FOB CONTAINING A UNIQUE EMBEDDED CODE IS PRESENT. **HILL START ASSIST.** AUTOMATICALLY APPLIES THE BRAKES MOMENTARILY TO HELP PREVENT ROLLBACK ON HILLS AND INCLINES. **PARKSENSE[®] REAR PARK ASSIST.^[3]** WHEN IN REVERSE, THIS AVAILABLE SYSTEM USES SENSORS TO DETECT THE PRESENCE OF OBJECTS IN THE BACKUP PATHWAY AND PROVIDES AN AUDIBLE AND VISUAL WARNING.

SAFETY. SECURITY.

ADVANCED MULTISTAGE FRONT AIR BAGS^[7]

HIGH-STRENGTH STEEL BODY

PARKSENSE[®] REAR PARK ASSIST^[3]

ACTIVE HEAD RESTRAINT SYSTEM^[8]

CRUMPLE ZONES

SUPPLEMENTAL SIDE-CURTAIN AIR BAGS^[7]

FOUR-WHEEL ANTILOCK DISC BRAKES

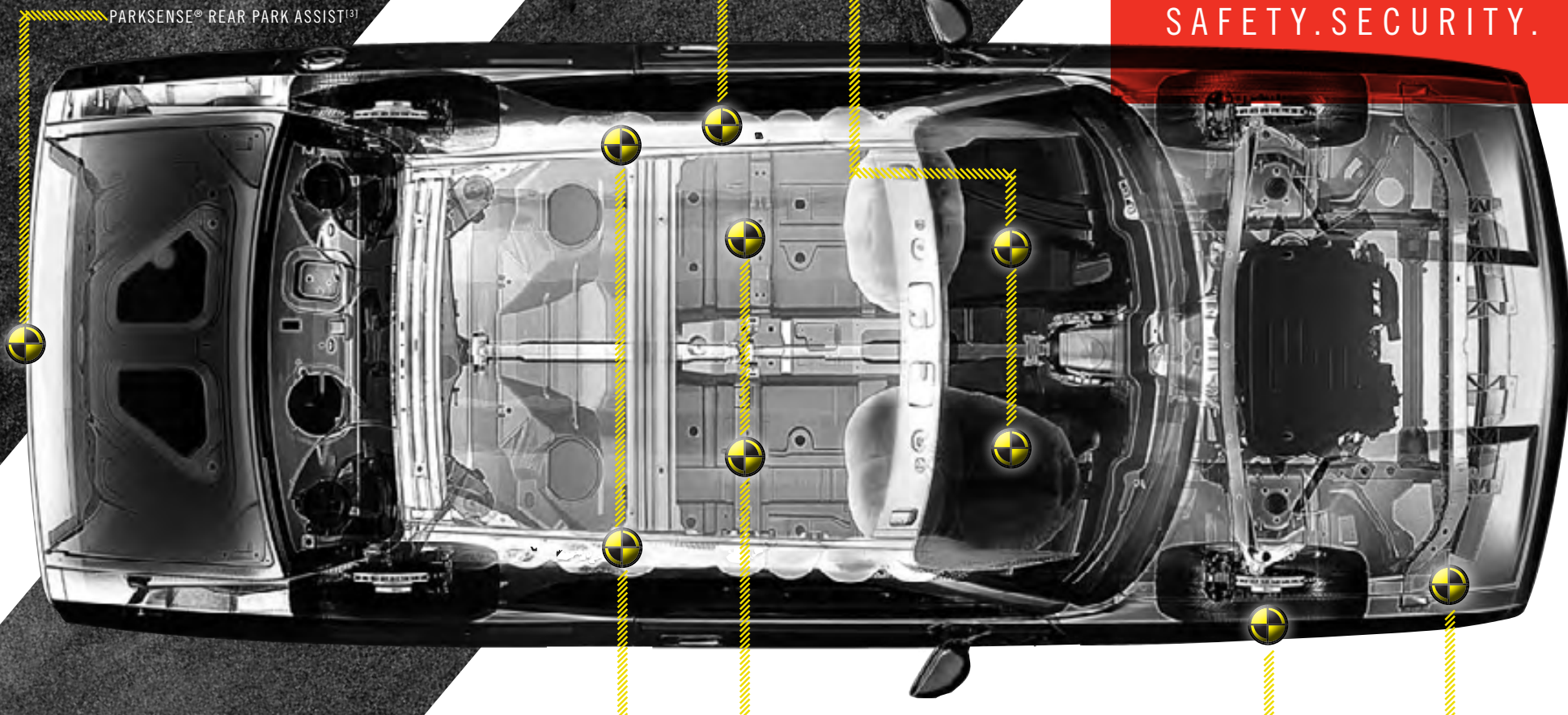



CHALLENGER R/T SHOWN IN PITCH BLACK WITH MOPAR® T/A HOOD, R/T RED STRIPE DECAL KIT, 20-INCH BLACK CLASSIC WHEELS, CALIPER COVER KIT, AND BLACK CHROME GRILLE SURROUND.

AUTHENTIC DODGE ACCESSORIES

SEE YOUR DEALER FOR A BROCHURE OF THE FULL LINE OF AUTHENTIC ACCESSORIES FOR YOUR DODGE CHALLENGER.



WITH YOU EVERY MILE. MOPAR IS WITH YOU THE MOMENT YOU GET YOUR NEW KEYS AND FOR EVERY MILE THEREAFTER. IT'S A BRAND THAT HELPS MAINTAIN AND MAKE YOUR RIDE YOUR OWN WITH PARTS AND ACCESSORIES OF EVERY KIND — ALL ORIGINAL EQUIPMENT DESIGNED BY THE SAME ENGINEERS OF YOUR VEHICLE — SPECIFICALLY FOR YOUR MODEL. IT'S NOT GUESSWORK, IT'S ABOUT GETTING-IT-RIGHT-THE-FIRST-TIME SATISFACTION WITH HIGH-QUALITY MATERIALS THAT HAVE BEEN THOROUGHLY TESTED FOR THE LONG HAUL. MOPAR ALSO ASSURES YOU WITH EXPERT TECHNICIANS WHO KNOW YOUR MAKE AND MODEL BEST, VEHICLE PROTECTION PLANS, EXPRESS LANE SERVICE, AND AN ONLINE OWNER CONNECT WEB SITE (REGISTER AT OWNERS.DODGE.COM). WELCOME TO MOPAR NATION. LEARN MORE ABOUT THE WORLD OF MOPAR AND ALL IT HAS TO OFFER AT MOPAR.COM



CHALLENGER SXT

POWERTRAIN

- 3.6L DOHC Pentastar® Variable Valve Timing (VVT) 24V V6
305 horsepower and 268 lb-ft of torque
5-speed automatic transmission with AutoStick

SELECT STANDARD EQUIPMENT

- 18-inch aluminum wheels
- Dual rear exhaust with bright tips
- Bright fuel filler door
- Twin hood scoops
- Premium cloth seating
- Keyless Enter 'n Go with proximity sensor
- Push button start
- Remote keyless entry
- Power 10-way driver's seat including power 4-way lumbar adjust
- Leather-wrapped tilt/telescoping steering wheel with cruise and audio controls
- Automatic Temperature Control (ATC)
- Trip computer
- Power windows and locks
- Power adjustable exterior mirrors
- Uconnect® 130 AM/FM/CD/MP3 radio with 6 speakers
- Active front head restraints^[8]
- 6 standard air bags,^[7] including driver and front-passenger air bags, side-curtain air bags, and front-seat side-mounted air bags
- 4-wheel antilock disc brakes
- Electronic Stability Control (ESC)^[2] with Hill Start Assist, Ready Alert Braking (RAB), All-Speed Traction Control, Brake Assist, and Rain Brake Support

SELECT OPTIONAL EQUIPMENT

- SiriusXM Satellite Radio^[5] with 1-year subscription
- Sound Group
- ParkSense® Rear Park Assist^[3]
- 3.06 rear axle ratio
- Uconnect Voice Command^[4] with Bluetooth®



CHALLENGER SXT PLUS

POWERTRAIN

- 3.6L DOHC Pentastar VVT 24V V6
305 horsepower and 268 lb-ft of torque
5-speed automatic transmission with AutoStick

SELECT STANDARD EQUIPMENT OVER SXT

- Premium Nappa leather-trimmed seats
- Heated front seats
- Fog lamps
- Automatic headlamps
- ParkSense Rear Park Assist^[3]
- Uconnect hands-free phone
- Auto-dimming rearview mirror with microphone
- 6 Boston Acoustics® speakers with 276-watt amplifier
- SiriusXM Satellite Radio^[5] with 1-year subscription
- Sun visors with illuminated vanity mirrors
- Remote USB port

SELECT OPTIONAL EQUIPMENT

- Super Sport Group (SS/T)
- Electronics Convenience Group
- Sound Group II
- Harman Kardon® Audio Group
- Uconnect 430N with 6.5-inch touch screen, Garmin® Navigation, and CD/DVD/MP3 radio
- Uconnect 730N with 6.5-inch touch screen, premium navigation, and CD/DVD/MP3 radio
- Power sunroof
- 20-inch polished forged aluminum wheels (requires Super Sport Group (SS/T))
- 20-inch chrome-clad aluminum wheels
- 3.06 rear axle ratio



CHALLENGER R/T

POWERTRAIN

- 5.7L HEMI® VVT V8
375 horsepower and 410 lb-ft of torque
TREMEC® 6-speed manual transmission
- 5.7L HEMI VVT V8 with Fuel Saver Technology
372 horsepower and 400 lb-ft of torque
5-speed automatic transmission with AutoStick

SELECT STANDARD EQUIPMENT OVER SXT

- Fog lamps
- Automatic headlamps
- Body-color rear spoiler
- Performance steering
- Performance suspension
- Antispin rear differential (6-speed manual transmission)
- Bright pedals (6-speed manual transmission)
- Steering wheel-mounted paddle shifters (5-speed automatic transmission)
- SiriusXM Satellite Radio^(S) with 1-year subscription
- Uconnect® Voice Command⁽⁴⁾ with Bluetooth®
- Auto-dimming rearview mirror with microphone
- Sun visors with illuminated vanity mirrors

SELECT OPTIONAL EQUIPMENT

- 5-speed automatic transmission
- 20-inch chrome-clad aluminum wheels
- Antispin rear differential (5-speed automatic transmission)
- Electronics Convenience Group
- Sound Group II
- Uconnect 430N with 6.5-inch touch screen, Garmin® Navigation, and CD/DVD/MP3 radio
- Uconnect 730N with 6.5-inch touch screen, premium navigation, and CD/DVD/MP3 radio
- Power sunroof
- Super Track Pak
- ParkSense® Rear Park Assist⁽³⁾
- Hood-to-fender stripes (Black, Red, or Silver)



CHALLENGER R/T PLUS

POWERTRAIN

- 5.7L HEMI VVT V8
375 horsepower and 410 lb-ft of torque
TREMEC 6-speed manual transmission
- 5.7L HEMI VVT V8 with Fuel Saver Technology
372 horsepower and 400 lb-ft of torque
5-speed automatic transmission with AutoStick

SELECT STANDARD EQUIPMENT OVER R/T

- Premium Nappa leather-trimmed seats
- Heated front seats
- 6 Boston Acoustics® speakers with 276-watt amplifier
- Power heated mirrors
- ParkSense Rear Park Assist⁽³⁾
- Temperature and compass gauge
- Universal Garage Door Opener
- Security alarm
- Tire pressure monitoring display
- Remote start

SELECT OPTIONAL EQUIPMENT

- 5-speed automatic transmission
- 20-inch chrome-clad aluminum wheels
- Antispin rear differential (5-speed automatic transmission)
- Sound Group II
- Harman Kardon® Audio Group
- High Intensity Discharge (HID) headlamps
- Uconnect 430N with 6.5-inch touch screen, Garmin Navigation, and CD/DVD/MP3 radio
- Uconnect 730N with 6.5-inch touch screen, premium navigation, and CD/DVD/MP3 radio
- Power sunroof
- Super Track Pak
- Hood-to-fender stripes (Black, Red, or Silver)



CHALLENGER R/T CLASSIC

POWERTRAIN

- 5.7L HEMI® VVT V8
375 horsepower and 410 lb-ft of torque
TREMEC® 6-speed manual transmission
- 5.7L HEMI VVT V8 with Fuel Saver Technology
372 horsepower and 400 lb-ft of torque
5-speed automatic transmission with AutoStick

SELECT STANDARD EQUIPMENT OVER R/T PLUS

- Unique 20-inch polished aluminum wheels with Black pockets (late availability)
- P245/45ZR20 BSW All-Season performance tires
- Functional hood scoops
- Dual R/T bodyside stripes (Black, Red, or White)
- Classic Challenger script badge
- Classic R/T badging
- High Intensity Discharge (HID) headlamps
- 3.92 rear axle ratio

SELECT OPTIONAL EQUIPMENT

- 20-inch polished forged aluminum wheels
- 5-speed automatic transmission
- Antispin rear differential (5-speed automatic transmission)
- Sound Group II
- Harman Kardon® Audio Group
- Uconnect® 430N with 6.5-inch touch screen, Garmin® Navigation, and CD/DVD/MP3 radio
- Uconnect 730N with 6.5-inch touch screen, premium navigation, and CD/DVD/MP3 radio
- Power sunroof
- Super Track Pak
- Stripe Delete



CHALLENGER SRT® 392

POWERTRAIN

- 392-cu-in SRT HEMI V8
470 horsepower and 470 lb-ft of torque
TREMEC 6-speed manual transmission
- 392-cu-in SRT HEMI V8
470 horsepower and 470 lb-ft of torque
5-speed automatic transmission with AutoStick

SELECT STANDARD EQUIPMENT OVER R/T CLASSIC

- Performance Nappa leather-trimmed seats with perforated suede inserts
- SRT unique leather-trimmed heated steering wheel
- 20-inch forged polished aluminum wheels with Black pockets
- P245/45ZR20 BSW All-Season performance tires
- Dual center stripes (Black, Gray, Red, or Silver)
- Launch Control
- Uconnect 430 with 6.5-inch touch screen and CD/DVD/MP3 radio
- 3-mode adaptive damping high-performance suspension
- Brembo® 4-piston brake calipers
- 4-wheel antilock disc performance brakes
- Tire service kit
- SRT performance pages integrated in Electronic Vehicle Information Center (EVIC)

SELECT OPTIONAL EQUIPMENT

- 5-speed automatic transmission
- 20-inch forged Black Vapor Chrome aluminum wheels
- Power sunroof
- Uconnect 430N with 6.5-inch touch screen, Garmin Navigation, and CD/DVD/MP3 radio
- Uconnect 730N with 6.5-inch touch screen, premium navigation, and CD/DVD/MP3 radio
- P245/45ZR20 / P255/45ZR20 performance tires
- Harman Kardon Audio Group
- Stripe Delete

COOL GEAR FOR YOUR CHALLENGER...



CHALLENGER RALLYE REDLINE

POWERTRAIN

- 3.6L DOHC Pentastar® Variable Valve Timing (VVT) 24V V6
305 horsepower and 268 lb-ft of torque
5-speed automatic transmission with AutoStick

SELECT STANDARD EQUIPMENT OVER SXT PLUS

- Unique 20-inch Black Chrome aluminum wheels with Red lip and backbone
- P245/45ZR20 BSW All-Season performance tires
- Rear body-color spoiler
- Unique Red center hood-to-tail stripe
- 3.06 rear axle ratio
- 4-wheel antilock disc performance brakes
- Performance steering
- Performance suspension
- Sport mode
- Steering wheel-mounted paddle shifters

SELECT OPTIONAL EQUIPMENT

- Electronics Convenience Group
- Power sunroof
- Sound Group II
- Harman Kardon® Audio Group
- Uconnect® 430N with 6.5-inch touch screen, Garmin® Navigation, and CD/DVD/MP3 radio
- Uconnect 730N with 6.5-inch touch screen, premium navigation, and CD/DVD/MP3 radio

CHALLENGER R/T BLACKTOP

POWERTRAIN

- 5.7L HEMI® VVT V8 375 horsepower and 410 lb-ft of torque
TREMEC® 6-speed manual transmission
- 5.7L HEMI VVT V8 with Fuel Saver Technology
372 horsepower and 400 lb-ft of torque
5-speed automatic transmission with AutoStick

SELECT STANDARD EQUIPMENT OVER R/T AND R/T PLUS

- Unique 20-inch Gloss Black aluminum wheels and center caps
- P245/45ZR20 BSW All-Season performance tires
- Unique hood-to-tail dual stripe in Matte Charcoal with Red perimeter
- Unique Black grille
- Unique Black fuel filler door
- Performance steering with variable displacement
- Sport suspension
- High-performance ABS brakes
- Available with Dark Slate Gray or Radar Red interior and Pitch Black, Granite Crystal Metallic, or Billet Silver Metallic exterior

SELECT OPTIONAL EQUIPMENT

- 5-speed automatic transmission
- Antispin rear differential (5-speed automatic transmission)
- Electronics Convenience Group (R/T)
- Uconnect 430N with 6.5-inch touch screen, Garmin Navigation, and CD/DVD/MP3 radio
- Uconnect 730N with 6.5-inch touch screen, premium navigation, and CD/DVD/MP3 radio
- Sound Group II
- Harman Kardon Audio Group (R/T Plus)
- Power sunroof
- ParkSense® Rear Park Assist⁽³⁾ (R/T)
- High Intensity Discharge (HID) headlamps (R/T Plus)

...OR FOR YOURSELF

CHECK OUT AN EXTENSIVE LINE OF GIFTS AND GEAR FOR THE DODGE ENTHUSIAST. FROM AUTHENTIC APPAREL TO DIE-CAST REPLICAS FOR THE COLLECTOR, AS WELL AS ELECTRONICS AND OFFICE SUPPLIES, ALL LIFESTYLE ITEMS ARE AS BOLD AS YOUR DODGE VEHICLE. REFER TO DODGE.COM/LIFE FOR OUR FULL PRODUCT LINEUP.

DODGE.COM/LIFE



GO MOBILE

TAKE A MULTIMEDIA TOUR OF YOUR VEHICLE ON YOUR MOBILE DEVICE. VISIT THE CHRYSLER GROUP LLC PAGE IN iTunes® FROM YOUR SMARTPHONE OR iPad® TO DOWNLOAD THE MOST UP-TO-DATE VEHICLE APPS. LOG ON TO THE DODGE.COM MOBILE SITE FOR AN AT-A-GLANCE REVIEW OF WHAT YOU NEED TO KNOW ABOUT YOUR DODGE VEHICLE. EXPERIENCE VISUAL AND INTERACTIVE DEMONSTRATIONS WHILE GAINING ACCESS TO PRODUCT INFORMATION AT YOUR FINGERTIPS, WHEREVER YOU GO.



CHALLENGER WHEELS

- A 18-inch aluminum
(standard on SXT, SXT Plus, R/T, and R/T Plus)
- B 20-inch chrome-clad aluminum
(optional on SXT Plus, R/T, and R/T Plus)
- C 20-inch polished aluminum with Black pockets (standard on R/T Classic; late availability)
- D 20-inch polished forged aluminum
(optional on R/T Classic)
- E 20-inch Gloss Black aluminum
(standard on R/T Blacktop)
- F 20-inch Black Chrome with Red lip and backbone (standard on Rallye Redline)
- G 20-inch polished forged aluminum with Black pockets (standard on SRT® 392)
- H 20-inch forged Black Vapor Chrome aluminum (optional on SRT 392)



CHALLENGER INTERIORS

A Momentum cloth/Wallace II cloth in Dark Slate Gray
(standard on SXT and R/T)

B Nappa leather trim with Nappa Axis perforated inserts in Dark Slate Gray
(standard on SXT Plus, Rallye Redline, R/T Plus, and R/T Classic)

C Nappa leather trim with Nappa Axis perforated inserts in Dark Slate
Gray/Radar Red (optional on SXT Plus, Rallye Redline, R/T Plus, and R/T Classic)

D Nappa leather trim with perforated suede inserts in Dark Slate Gray
(standard on SRT® 392)

E Nappa leather trim with perforated suede inserts in Radar Red
(optional on SRT 392)

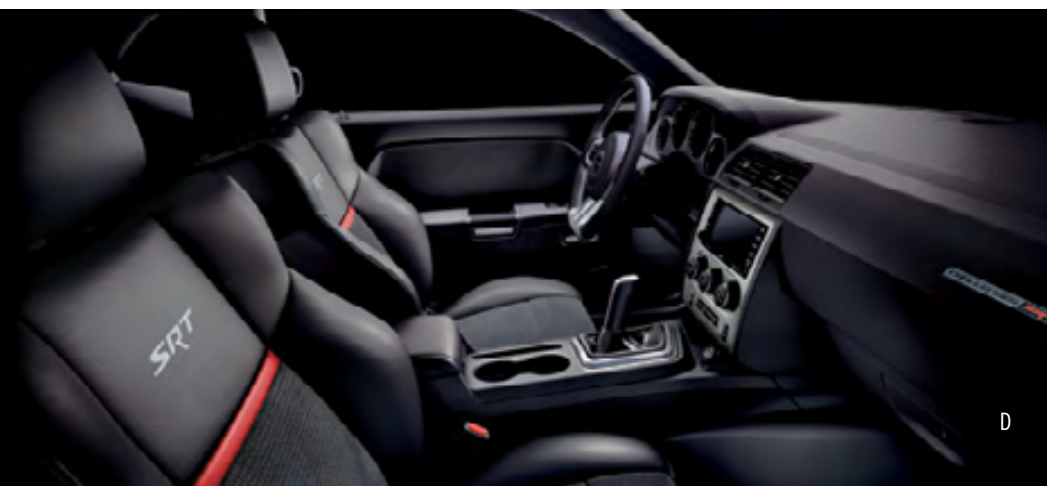

CHALLENGER EXTERIORS

- 1 JAZZ BLUE PEARL
- 2 REDLINE TRI-COAT PEARL
- 3 PHANTOM BLACK TRI-COAT PEARL
- 4 GRANITE CRYSTAL METALLIC
- 5 PITCH BLACK
- 6 BRIGHT WHITE
- 7 BILLET SILVER METALLIC

NOT ALL MODELS AVAILABLE IN ALL COLORS.
SEE YOUR DEALER FOR DETAILS.

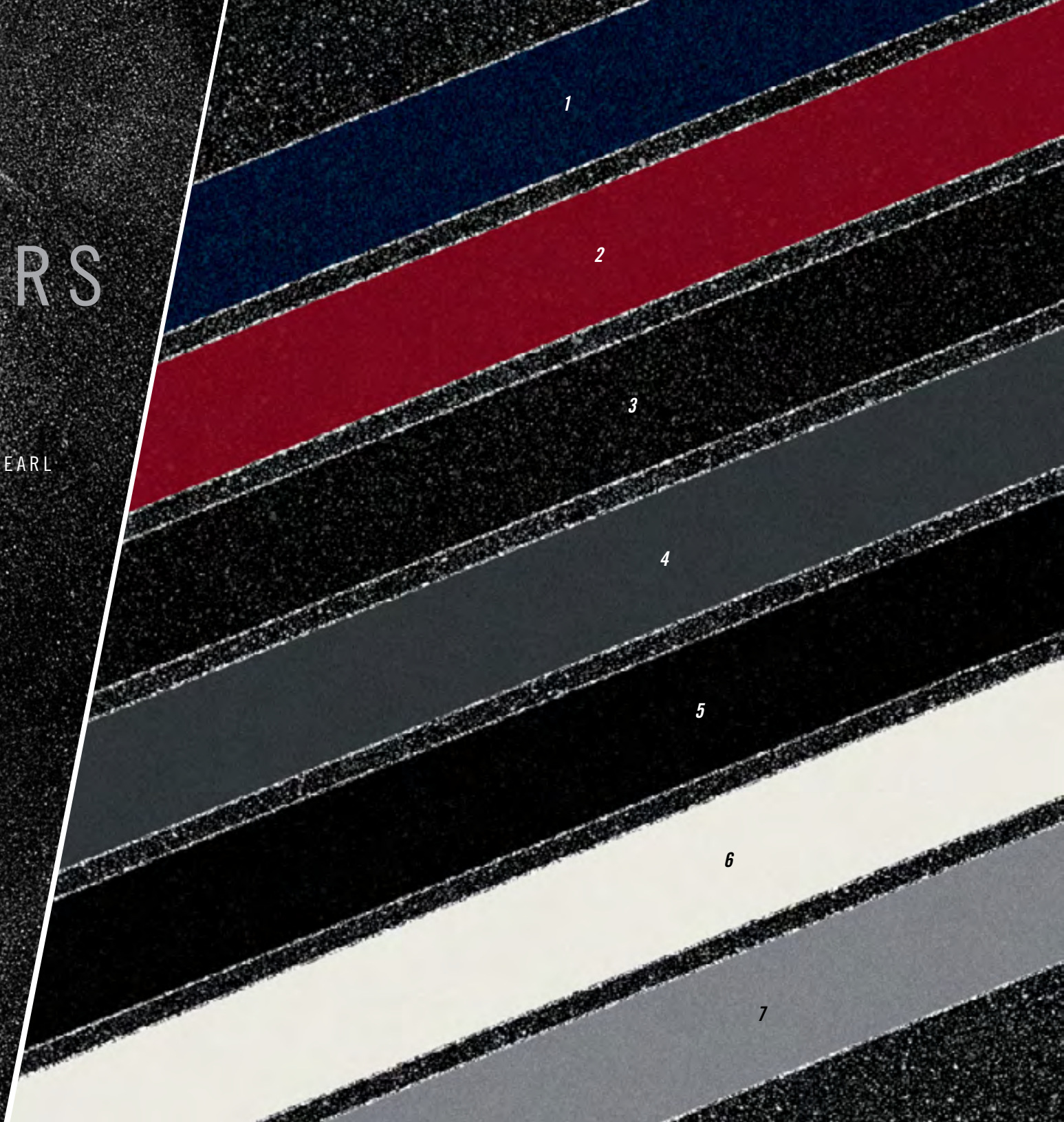



// DODGE.COM/CHALLENGER



CHALLENGER R/T PLUS SHOWN IN BILLET SILVER METALLIC.



CHALLENGER



CHARGER



DART



AVENGER



GRAND CARAVAN



DURANGO



JOURNEY



DODGE.COM // 800-4ADODGE

DODGE IS A REGISTERED TRADEMARK OF CHRYSLER GROUP LLC.



Join our community on Facebook, follow us on Twitter, and check us out on YouTube.

[1] Based on latest available competitive information and Ward's Middle Specialty Vehicle segmentation. [2] No system, no matter how sophisticated, can repeal the laws of physics or overcome careless driving actions. Performance is limited by available traction, which snow, ice, and other conditions can affect. When the ESC warning lamp flashes, the driver needs to use less throttle and adapt speed and driving behavior to prevailing road conditions. Always drive carefully, consistent with conditions. Always wear your seat belt. [3] Always check entire surroundings before backing up. [4] Requires Uconnect Phone. [5] Sirius services require subscriptions, sold separately after the 12-month trial included with new vehicle purchase. If you decide to continue your service at the end of your trial subscription, the plan you choose will automatically renew and bill at then-current rates until you call SiriusXM at 1-866-635-2349 to cancel. See SiriusXM Customer Agreement for complete terms at siriusxm.com. All fees and programming subject to change. Sirius satellite service is available only to those at least 18 and older in the 48 contiguous U.S., D.C., and P.R. (with coverage limitations). Our Internet radio service is available throughout our satellite service area and in AK and HI. Traffic information not available in all markets. See siriusxm.com/traffic for details. ©2012 Sirius XM Radio Inc. Sirius, XM and all related marks and logos are trademarks of Sirius XM Radio Inc. [6] Transferable. See dealer for complete details and a copy of the 5-Year/100,000-Mile Powertrain Limited Warranty. [7] The Advanced Front Air Bags in this vehicle are certified to the new U.S. federal regulations for advanced air bags. Children 12 years old and younger should always ride buckled up in a rear seat. Infants in rear-facing child restraints should never ride in the front seat of a vehicle with a passenger front air bag. All occupants should always wear their lap and shoulder belts properly. [8] Always sit properly with the head restraint properly adjusted. Never place anything in front of the head restraint. About this catalog: Since the time of publication, some of the information you'll find in this brochure may have been updated. Ask your dealer for details. Some of the equipment shown or described throughout this catalog may be available at extra cost. Specifications, descriptions, illustrative materials, and all competitive comparisons contained herein are as accurate as known at the time this brochure was approved for publication. Chrysler Group LLC reserves the right to discontinue models at any time or change specifications without notice or without incurring obligation. Options may be required in combination with other options. For the price of the model with the equipment you desire, or verification of specifications contained here, see your Dodge dealer. iPod, iPad, and iTunes are registered trademarks of Apple Inc. All rights reserved. Sirius, XM and all related marks and logos are trademarks of Sirius XM Radio Inc. Bluetooth is a registered trademark of Bluetooth SIG, Inc. Garmin and the Garmin logo are registered trademarks of Garmin, Ltd. or its subsidiaries and are registered in one or more countries, including the U.S. Boston Acoustics and the Boston Acoustics logo are registered trademarks of Boston Acoustics, Inc. All rights reserved. The Best Buy Seal and other licensed materials are registered certification marks and trademarks of Consumers Digest Communications, LLC, used under license. For award information, visit ConsumersDigest.com. Goodyear is a registered trademark of The Goodyear Tire & Rubber Company. All rights reserved. Brembo is a registered trademark of Freni Brembo S.p.A. TREMEC is a registered trademark of Transmisiones y Equipos Mecanicos, S.A. de C.V. Harman Kardon and logo are registered trademarks of Harman International Industries, Inc. Facebook and logo are registered trademarks of Facebook, Inc. The Twitter logo is a service mark of Twitter, Inc. The YouTube logo is a trademark of Google Inc. Dodge, Challenger, Avenger, Charger, Dart, Durango, Grand Caravan, Journey, HEMI, Mopar, ParkSense, Pentastar, R/T, Blacktop, SXT, Sentry Key, SRT, and Uconnect are registered trademarks of Chrysler Group LLC. ©2012 Chrysler Group LLC. All rights reserved.