

# CHEVROLET



1937 Chevrolet, 2-dr. sedan, AA

**1937**

**CHEVROLET**  
**1937**  
**SPECIFICATIONS**

PREPARED BY  
ENGINEERING DEPARTMENT  
CHEVROLET DIVISION  
GENERAL MOTORS CORPORATION  
DETROIT, MICHIGAN

LITHOGRAPHED IN U.S.A.  
NOVEMBER 1936

## CHEVROLET 1937 SPECIFICATIONS

## FOREWORD

The following specifications are prepared by the Chevrolet Engineering Department for use by authorized persons within the Chevrolet organization. All data contained herein pertain to cars and trucks manufactured for domestic use only. No information is

furnished concerning specially built cars or trucks or those exported to other countries. Except where noted, all data quoted are for cars and trucks with regular equipment. All 1937 specifications which are the same as 1936 specifications are denoted by the symbol  $\phi$ .

## TABLE OF CONTENTS

<u>Section</u>	<u>Sheet</u>
Contents	1
Serial Numbers; Models; Symbols	2
Weights of Passenger Cars	3
Weights of Trucks	4
Exterior Dimensions of Passenger Cars	5
Interior Dimensions of Passenger Cars	6-7
Luggage Space	8-9
Sedan Delivery, Coupe Pickup and Truck Dimensions	10-14
Frame; Front Wheel Alignment	15
Front Suspension	16-17
Clutch; Steering	18
Springs	19-20
Shock Absorbers; Transmission	21
Rear Axle	22
Propeller Shaft; Universal Joints	23
Brakes	24
Engine and Power Curves	25-31
Engine RPM and Piston Speed Charts	32-33
Wheel and Tires	34-35
Electrical; Tools	36-38
Splines	39
Anti-Friction Bearings	40
Lubrication Chart	41

## CHEVROLET 1937 SPECIFICATIONS

Supersedes Sheet No. 2 Dated 11-18-36

SERIAL NUMBERS		PASSENGER CARS			TRUCKS	
Designation Letters		MASTER DELUXE	MASTER	HALF TON	1 1/2 TON	
		GA	GB	GC	SA = 131-1/2" Single SB = 131-1/2" Dual @ SC = 157" Single SD = 157" Dual @	
Vehicle Serial Numbers	Numbers	Each designation letter starts with 1001, and follows in numerical sequence at each Plant.				
	Location	On plate under hood on right side of cowl panel.				
Engine Serial Numbers	Numbers	#1 and up in numerical sequence.				
	Prefix	None		K	T	
	Location	Stamped on right side of engine case just in front of fuel pump.				
Trans. Serial Numbers	Trans. - Toledo				Prefix - TB	
	Saginaw	Prefix - SA		Prefix - SM		
	Muncie Prod.	Prefix - MP		Prefix - M		
		Each prefix will start with 00001 & run up to 99999 when prefix will change to next alphabetical letter, as follows, SA to SB, MP to MR, etc.				
	Location	Stamped on milled surface on top of rear end of trans. case.				
Rear Axle Serial Numbers	Numbers	No mark	Prefix - C	Reg. - No mark	Reg. prefix - TR	
		Numerical sequence #1001 and up			Opt. prefix - HTR	
	Location	Stamped in casting on top forward end of differential carrier.				

@ - "Gross allowable weights" sheet #4.

PASSENGER CAR SYMBOLS	MASTER DELUXE (DMAS)	MASTER (MAS)
Chassis	FCB	FCB
Sedan	SED	SED
Club Sedan (Sport Sedan)	CSED	CSED
Coach	COA	COA
Town Sedan	TSED	TSED
Coupe 2 (Business Coupe)	CPE2	CPE2
Sport Coupe	SCPE	----
Cabriolet	----	CBL
Sedan Delivery	----	SDL

TRUCK AND BODY SYMBOLS	HALF TON	1 1/2 TON	
	112" WB	131-1/2" WB	157" WB
Chassis with cowl-single rear wheels	GCH	UCH	ULCH
-dual rear wheels	----	DCH	DLCH
Chassis with cab-single rear wheels	CGAB	UCAB	ULCA
-dual rear wheels	----	DCAB	DLCA
Chassis, cab and pickup body	CCEX	----	----
Two-unit open express body (Pickup)	PUB	UX	----
Pickup top used with pickup body	PUBT	----	----
Chassis with panel body	CPAN	UPAN	----
Panel body	CPN	UPN	----
Single unit express body (Canopy Express)	CXST	UXST	----
Closed suburban body (Carryall suburban)	CCS	----	----
Dual wheel chassis, cab and stake body	----	DST	DLST
Platform	----	UPLA	DPLA
Stake rack used with above platform	----	USTA	DSTA
Stock rack used with above platform	----	----	DSTO
Express platform body	----	----	DPLX
Express racks used with above platform	----	----	DSTX

REVISIONS: Engine Serial Number Location Revised

# CHEVROLET 1937 SPECIFICATIONS

Supersedes Sheet No. 3 Dated 11-18-36

PASSENGER CAR WEIGHTS	MASTER DELUXE		MASTER	
	Shipping	Curb	Shipping	Curb
Chassis				
On front wheels				
On rear wheels				
Sedan	2935#	3055#	2845#	2965#
On front wheels	1500#	1515#	1425#	1440#
On rear wheels	1435#	1540#	1420#	1525#
Sport Sedan	2960#	3080#	2885#	3005#
On front wheels	1495#	1510#	1420#	1435#
On rear wheels	1465#	1570#	1465#	1570#
Coach	2910#	3030#	2800#	2920#
On front wheels	1485#	1500#	1415#	1430#
On rear wheels	1425#	1530#	1385#	1490#
Town Sedan	2935#	3055#	2830#	2950#
On front wheels	1480#	1495#	1405#	1420#
On rear wheels	1455#	1560#	1425#	1530#
Coupe 2 (Business Coupe)	2840#	2960#	2770#	2910#
On front wheels	1520#	1570#	1445#	1495#
On rear wheels	1320#	1410#	1325#	1415#
Sport Coupe	2880#	3000#		
On front wheels	1515#	1530#	- - -	- - -
On rear wheels	1365#	1470#		
Pickup Coupe				
On front wheels	- - -	- - -		
On rear wheels				
Cabriolet			2790#	2910#
On front wheels	- - -	- - -	1445#	1460#
On rear wheels			1345#	1450#
Sedan Delivery			2810#	2950#
On front wheels	- - -	- - -	1425#	1475#
On rear wheels			1385#	1475#

Shipping weight is the total weight of the vehicle less passengers, gasoline and water. This includes front and rear bumpers (bumper guards on Master Deluxe), spare tire and tire cover where required.

Truck shipping weight is the total weight of the truck less load, driver, spare tire, gasoline and water, but with oil and grease.

Curb weight is the weight of the vehicle ready to drive. It is the shipping weight plus gasoline and water.

**TRUCK GROSS ALLOWABLE WEIGHTS.**

(Chassis, Cab, Body, driver and payload).

- Half Ton 4400#
- Half Ton (6.00-20-6) 4600#
- 1 1/2 Ton (32 x 6-8)S. 7600#
- 1 1/2 Ton (6.00-20-6)D. 9300#
- 1 1/2 Ton (32 x 6-10)D. (Auxiliary Springs) 11300#
- 1 1/2 Ton (6.50-20-6) front, (32 x 6-10)D. rear, Auxiliary Springs and Governor 12300#

TRUCK WEIGHTS	HALF TON		1 1/2 TON			
	112" W.B.		131-1/2" W.B.		157" W.B.	
	Shipping	Curb	Shipping	Curb	Shipping	Curb
Chassis with cowl	2190#	2320#	3030#	3225#	3075#	3270#
On front wheels	1335#	1395#	1685#	1765#	1760#	1850#
On rear wheels	855#	925#	1345#	1460#	1315#	1420#
Chassis and cab	2575#	2715#	3590#	3585#	3435#	3530#
On front wheels	1535#	1620#	1910#	1990#	1985#	2075#
On rear wheels	1040#	1095#	1480#	1595#	1450#	1555#
Chassis, cab and pickup	2805#	2945#			- - -	- - -
On front wheels	1530#	1615#			- - -	- - -
On rear wheels	1275#	1330#			- - -	- - -
Panel truck	3030#	3160#			- - -	- - -
On front wheels	1465#	1525#			- - -	- - -
On rear wheels	1565#	1635#			- - -	- - -
Single unit express (Canopy Express)	3060#	3180#			- - -	- - -
On front wheels	1500#	1560#			- - -	- - -
On rear wheels	1550#	1620#			- - -	- - -
Carryall Suburban			- - -	- - -	- - -	- - -
On front wheels			- - -	- - -	- - -	- - -
On rear wheels			- - -	- - -	- - -	- - -

## CHEVROLET 1937 SPECIFICATIONS

Supersedes Sheet No. 4 Dated 11-18-36

TRUCK WEIGHTS (Continued)	1 1/2 TON			
	131-1/2" W.B.		157" W.B.	
	Shipping	Curb	Shipping	Curb
Dual chassis and cowl	3120#	3300#	3200#	3380#
On front wheels (6.00-20-6 ply)	1665#	1745#	1735#	1825#
On rear wheels (6.00-20-6 ply)	1455#	1555#	1465#	1555#
Dual chassis and cab	3490#	3670#	3560#	3740#
On front wheels (6.00-20-6 ply)	1890#	1970#	1970#	2060#
On rear wheels (6.00-20-6 ply)	1600#	1700#	1590#	1680#
Dual chassis and cab	3550#	3745#	3630#	3825#
On front wheels (6.00-20-6 ply)	1875#	1955#	1975#	2065#
On rear wheels (32 x 6-8 ply)	1675#	1790#	1655#	1760#
Dual chassis and cab	3720#	3935#	3790#	4005#
On front wheels (6.00-20-6 ply)	1865#	1945#	1965#	2050#
On rear wheels (32 x 6-10 ply)	1855#	1995#	1825#	1955#
Dual chassis and cab			3640#	3835#
On front wheels (32 x 6-8 ply)	- - -	- - -	1995#	2085#
On rear wheels (32 x 6-8 ply)			1645#	1750#
Dual chassis and cab			3875#	4090#
On front wheels (32 x 6-10 ply)	- - -	- - -	2040#	2125#
On rear wheels (32 x 6-10 ply)			1835#	1965#
Dual stake			4890#	5105#
On front wheels (32 x 6-10 ply)	- - -	- - -	2100#	2185#
On rear wheels (32 x 6-10 ply)			2790#	2920#
Dual stake	4295#	4475#	4595#	4775#
On front wheels (6.00-20-6 ply)	1870#	1950#	2025#	2125#
On rear wheels (6.00-20-6 ply)	2425#	2525#	2570#	2660#
Dual stake	4370#	4565#		
On front wheels (6.00-20-6 ply)	1880#	1940#	- - -	- - -
On rear wheels (32 x 6-8 ply)	2510#	2625#		
Dual stake	4535#	4730#	4805#	5020#
On front wheels (6.00-20-6 ply)	1840#	1915#	2025#	2110#
On rear wheels (32 x 6-10 ply)	2695#	2835#	2780#	2910#
Dual stake			4655#	4850#
On front wheels (32 x 6-8 ply)	- - -	- - -	2040#	2130#
On rear wheels (32 x 6-8 ply)			2615#	2720#

TRUCK BODY WEIGHTS	HALF TON	1 1/2 TON	
	112" W.B.	131-1/2" W.B.	157" W.B.
Cab		480#	
Flat face cowl		76#	
Cowl and windshield		105#	
Pick-up box	230#	460#	- -
Top and curtains for above box	100#	- -	- -
Carryall suburban	1048#	- -	- -
Panel	928#	1077#	- -
Single unit (Canopy) express	890#	1012#	- -
Side and rear screens for above body	60#	75#	- -
Platform	- -	515#	694#
Stake racks	- -	290#	341#
Stock racks	- -	- -	589#
Express platform	- -	- -	680#
Express racks	- -	- -	376#

REVISIONS: Chassis and body weights added

# CHEVROLET 1937 SPECIFICATIONS

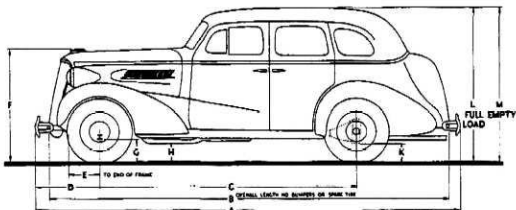
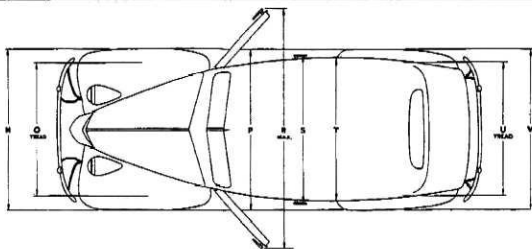

## EXTERIOR DIMENSIONS

	MASTER DELUXE					MASTER						
	SPORT SEDAN	TOWN SEDAN	SEDAN	COACH	BUSINESS COUPE	SPORT COUPE	SPORT SEDAN	TOWN SEDAN	SEDAN	COACH	BUSINESS COUPE	CARRI- OLET
A	184-7/8	184-7/8	187-1/4	187-1/4	184-7/8	187-1/4	184-7/8	184-7/8	187-1/4	187-1/4	184-7/8	187-1/4
B	173-1/4	173-1/4	171-3/4	171-3/4	171-3/4	171-3/4	173-1/4	173-1/4	171-3/4	171-3/4	171-3/4	171-3/4
C	112-1/4	112-1/4	112-1/4	112-1/4	112-1/4	112-1/4	112-1/4	112-1/4	112-1/4	112-1/4	112-1/4	112-1/4
D	27-7/8	27-7/8	27-7/8	27-7/8	27-7/8	27-7/8	27-7/8	27-7/8	27-7/8	27-7/8	27-7/8	27-7/8
E	15-1/2	15-1/2	15-1/2	15-1/2	15-1/2	15-1/2	15-1/2	15-1/2	15-1/2	15-1/2	15-1/2	15-1/2
F	48-1/2	48-1/2	48-1/2	48-1/2	48-1/2	48-1/2	49-9/16	49-9/16	49-9/16	49-9/16	49-9/16	49-9/16
G	9-3/8	9-3/8	9-3/8	9-3/8	9-3/8	9-3/8	8-5/8	8-5/8	8-5/8	8-5/8	8-5/8	8-5/8
H	8-1/4	8-1/4	8-1/4	8-1/4	8-1/4	8-1/4	9	9	9	9	9	9
K	8-1/2	8-1/2	8-1/2	8-1/2	8-1/2	8-1/2	8-1/2	8-1/2	8-1/2	8-1/2	8-1/2	8-1/2
L	66-7/8	66-7/8	66-7/8	66-7/8	66-1/8	66-1/8	66-7/8	66-7/8	66-7/8	66-7/8	66-1/8	66-1/4
M	87-3/4	87-3/4	87-3/4	87-3/4	87-1/4	87-1/4	88-3/8	88-3/8	88-3/8	88-3/8	87-1/4	87-3/8
N	69-3/4	69-3/4	69-3/4	69-3/4	69-3/4	69-3/4	69-3/4	69-3/4	69-3/4	69-3/4	69-3/4	69-3/4
O	57-1/4	57-1/4	57-1/4	57-1/4	57-1/4	57-1/4	56-3/8	56-3/8	56-3/8	56-3/8	56-3/8	56-3/8
P	70-1/4	70-1/4	70-1/4	70-1/4	70-1/4	70-1/4	70-1/4	70-1/4	70-1/4	70-1/4	70-1/4	70-1/4
Q												
R												
S	67-1/4	67-1/4	67-1/4	67-1/4	67-1/4	67-1/4	67-1/4	67-1/4	67-1/4	67-1/4	67-1/4	67-1/4
T	62-1/2	62-1/2	62-1/2	62-1/2	62-1/2	62-1/2	62-1/2	62-1/2	62-1/2	62-1/2	62-1/2	62-1/2
U	27-9/16	27-9/16	27-9/16	27-9/16	27-9/16	27-9/16	27-9/16	27-9/16	27-9/16	27-9/16	27-9/16	27-9/16
V	89-5/16	89-5/16	89-5/16	89-5/16	89-5/16	89-5/16	89-5/16	89-5/16	89-5/16	89-5/16	89-5/16	89-5/16

Note: - Car height figures depend on tire pressures, load and load distribution.

# CHEVROLET 1937 SPECIFICATIONS

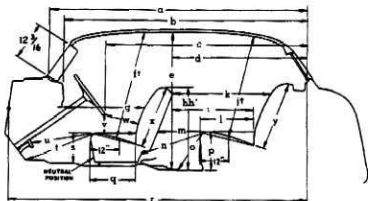

↑ Taken 15" over from car.

## PASSENGER CARS

	SPORT SEDAN	TOWN SEDAN	SEDAN	COACH	BUSINESS COUPE	SPORT COUPE	CABRI- OLET
a	92"	92"	92"	92"	61-1/4"	61-1/4"	66-1/2"
b	86-7/8"	86-7/8"	86-7/8"	86-7/8"	56"	56"	61-3/8"
c	73"	73"	73"	73"	42-1/4"	42-1/8"	47-1/2"
d	49-1/2"	49-1/2"	49-1/2"	49-1/2"	18-1/2"	17-3/4"	- -
e	48-1/8"	48-1/8"	48-1/8"	48-1/8"	- -	- -	- -
f	36-7/8"	36-7/8"	36-7/8"	36-7/8"	36-1/4"	36-1/4"	36-3/4"
g	29"	29"	29"	29"	29"	29-1/2"	29"
h	30-1/2"	30-1/2"	30-1/2"	30-1/2"	31-1/4"	30-1/2"	- -
h'	30-1/2"	29"	30-1/2"	29"	31-1/4"	- -	30-1/4"
i	30-1/8"	30-1/8"	30-1/8"	30-1/8"	- -	- -	- -
j	35-1/2"	35-1/2"	35-1/2"	35-1/2"	- -	- -	- -
k	37"	37"	37"	37"	- -	- -	- -
l	18-5/8"	18-5/8"	18-5/8"	18-5/8"	- -	- -	- -
m	35-3/4"	35-3/4"	35-3/4"	35-3/4"	- -	- -	- -
n	42-1/2"	43-1/2"	42-1/2"	41-1/2"	- -	- -	- -
o	37-9/16"	37-9/16"	37-9/16"	37-9/16"	- -	34-1/8"	34-1/8"
p	13-5/8"	13-5/8"	13-5/8"	13-5/8"	- -	- -	- -
q	18-3/16"	18-3/16"	18-3/16"	18-3/16"	18-3/16"	16-3/16"	18-3/8"
r	106"	106"	106"	106"	75-1/8"	75-1/8"	80-1/2"
s	12-3/4"	12-3/4"	12-1/2"	12-3/4"	12-3/4"	12-3/4"	- -
t	37-3/4"	37-3/4"	37-3/4"	37-3/4"	37-3/4"	37-3/4"	37-3/4"
u	34-5/8"	34-5/8"	34-5/8"	34-5/8"	34-5/8"	34-5/8"	34-5/8"
v	6-7/8"	6-7/8"	6-7/8"	6-7/8"	6-7/8"	6-7/8"	6-7/8"
w	11-3/8"	11-3/8"	11-3/8"	11-3/8"	11-3/8"	11-3/8"	11-3/8"
x	23-1/2"	23-1/2"	23-1/2"	23-1/2"	23-1/2"	23-1/2"	- -
y	25-3/4"	25-3/4"	25-3/4"	25-3/4"	- -	- -	- -

h = MASTER DELUXE

h' = MASTER

@ - This dimension measured in car.



# CHEVROLET 1937 SPECIFICATIONS

Supersedes Sheet No. 7 Dated 11-18-36

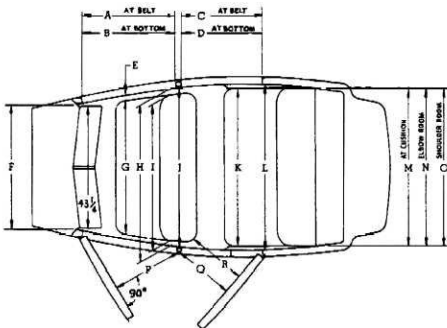

PASSENGER CARS

	SPORT SEDAN	TOWN SEDAN	SEDAN	COACH	BUSINESS COUPE	SPORT COUPE	CADRI- OLET
A	32-5/8"	42-5/8"	32-5/8"	42-5/8"	38-3/8"	38-3/8"	39-7/16"
B	32-1/2"	43"	32-1/2"	43"	38"	38"	
C	28"	--	28"	--	--	--	--
D	17"	--	17"	--	--	--	--
E	2"	3"	2"	3"	3"	3"	3"
F	44-1/4"	44-1/4"	44-1/4"	44-1/4"	44-1/4"	44-1/4"	44-1/4"
G	46"	46"	48"	46"	46"	46"	46"
H	52"	53"	52"	54"	53"	53"	
I	48"	45-1/2"	48"	45-1/2"	46"	45-1/2"	
J	52"	54"	52"	54-1/2"	54"	54"	
K	52-1/2"	49-1/2"	52-1/2"	50"	--	--	--
L	54"	--	54"	--	--	--	--
M	45"	45"	45"	45"	--	43"	43"
N	56"	52"	56"	52-1/2"	--	--	--
O	52-1/2"	52-1/2"	52-1/2"	52-1/2"	--	--	--
P	25"	37"	28"	38"	34"	34"	
Q	20"	--	22"	--	--	--	--
R	19"	--	20"	--	--	--	--

Ⓢ - This dimension measured in car.

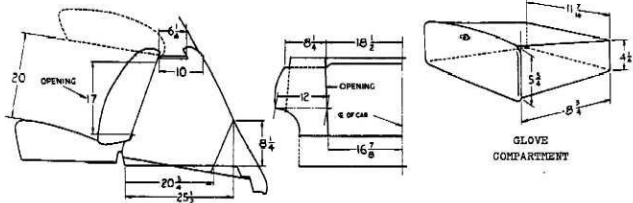
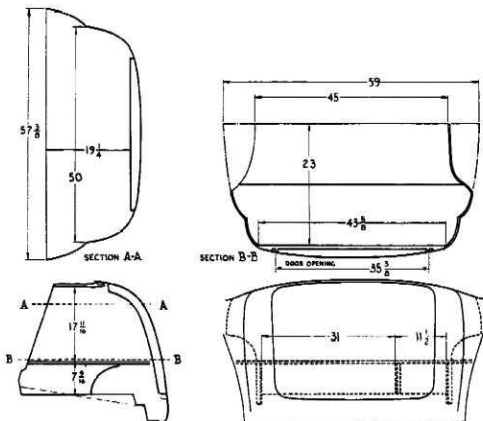

# CHEVROLET 1937 SPECIFICATIONS

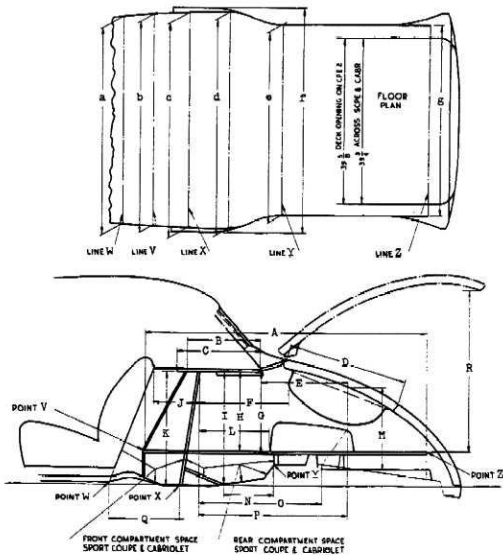

	SPORT COUPE	CABRIOLET	BUSINESS COUPE
A	- -	- -	64-3/4"
B	- -	- -	17"
C	18"	19-1/4"	18-1/2"
D	27-5/8"	27-5/8"	- -
E	20-5/8"	21-3/4"	- -
F	21"	21-1/2"	- -
G	19-1/2"	15-1/2"	- -
H	- -	- -	19"
I	28-1/2"	22-1/2"	- -
J	11"	12"	- -
K	27"	23"	- -
L	17-1/8"	17-5/8"	- -
M	18-1/2"	18-1/2"	- -

(CONTINUED)			
	SPORT COUPE	CABRIOLET	BUSINESS COUPE
N	11-1/4"	11-1/4"	- -
O	28-3/8"	28-7/8"	- -
P	34-1/2"	36"	- -
Q	16-5/8"	16-5/8"	- -
R	- -	- -	39-1/4"
a	48-3/4"	48-3/4"	- -
b	- -	- -	50"
c	50-3/4"	50-3/4"	- -
d	50-3/4"	50-3/4"	- -
e	44-3/4"	44-3/4"	44-3/4"
f	- -	- -	54-1/4"
g	- -	- -	44"

# CHEVROLET 1937 SPECIFICATIONS

Supersedes Sheet No. 10 Dated 11-18-35

Unless otherwise specified, all vertical dimensions are given for loaded condition.

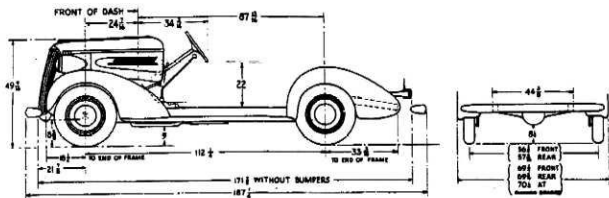

PASSENGER CAR CHASSIS

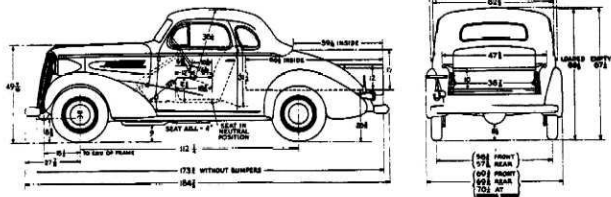

COUPE PICKUP  
(Master Chassis)

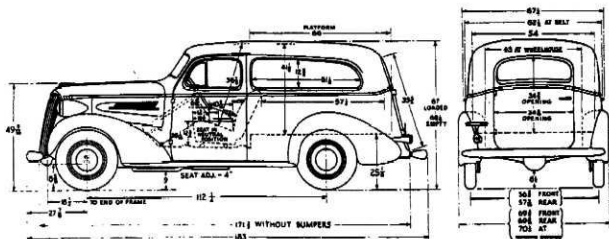

SEDAN DELIVERY (Master Chassis)

# CHEVROLET 1937 SPECIFICATIONS

Supersedes Sheet No. 11 Dated 11-18-36

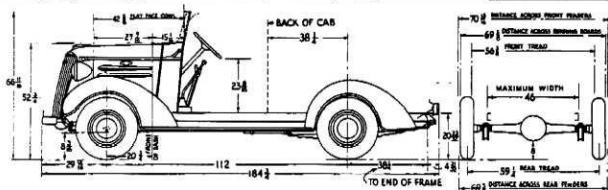

HALF TON CHASSIS

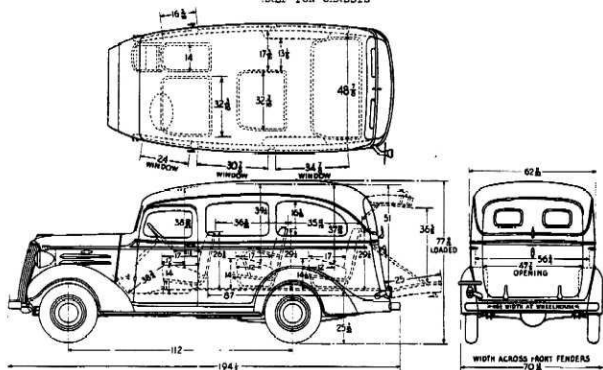

HALF TON  
CARRYALL SUBURBAN

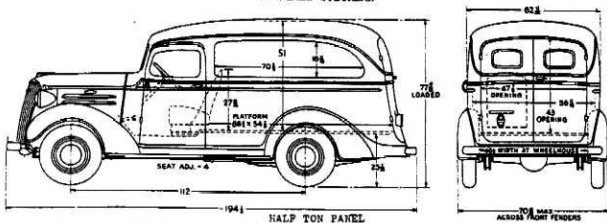

HALF TON PANEL

# CHEVROLET 1937 SPECIFICATIONS

Supersedes Sheet No. 12 Dated 11-18-36

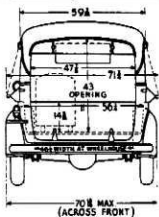
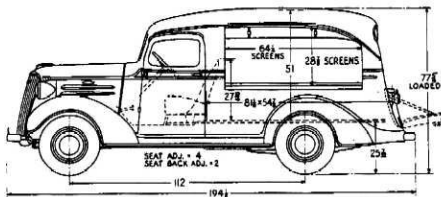

HALF TON CANOPY EXPRESS

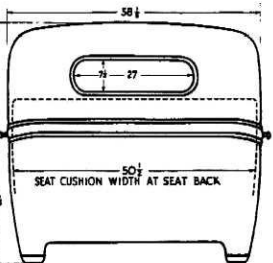
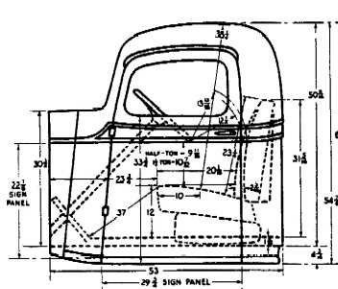

DOOR OPENING WIDTH AT BELT - 28"

TRUCK CAB  
(Used on HALF TON  
& 1 1/2 TON Chassis)

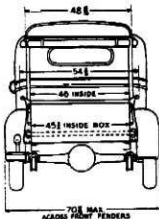
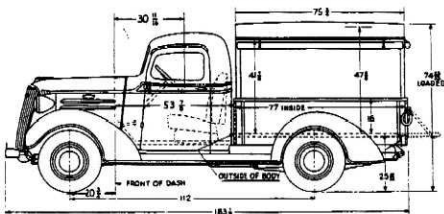

HALF TON PICKUP

# CHEVROLET 1937 SPECIFICATIONS

Supersedes Sheet No. 13 Dated 11-18-36

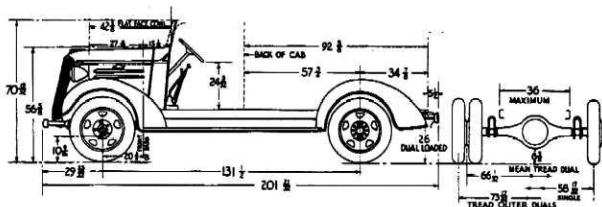

131-1/2" 1 1/2 TON CHASSIS

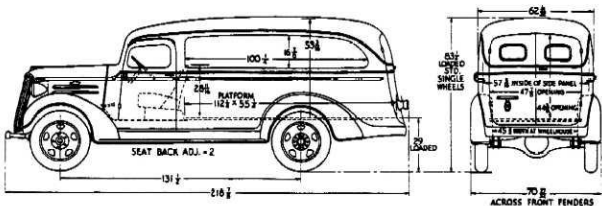

131-1/2" 1 1/2 TON PANEL

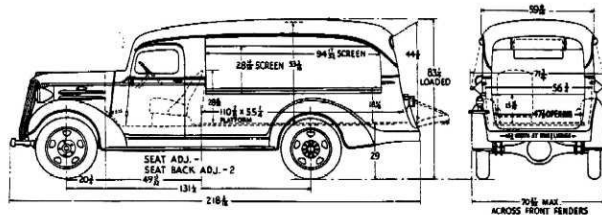

131-1/2" 1 1/2 TON CANOPY EXPRESS

# CHEVROLET 1937 SPECIFICATIONS

Supersedes Sheet No. 14 Dated 11-18-36

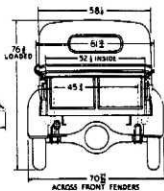
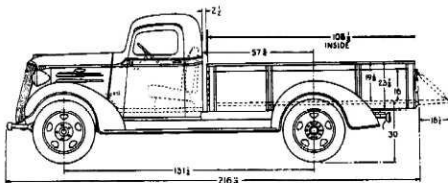

131-1/2" 1 1/2 TON  
OPEN EXPRESS PICKUP

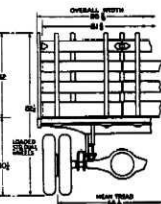
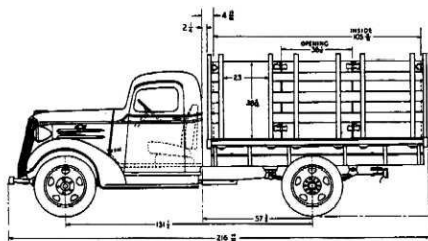

131-1/2" 1 1/2 TON STAKE

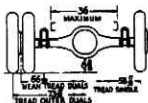
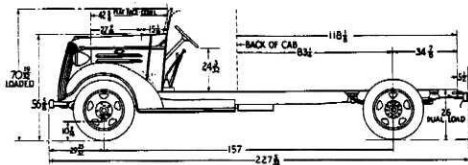

157" 1 1/2 TON TRUCK  
CHASSIS



# CHEVROLET 1937 SPECIFICATIONS

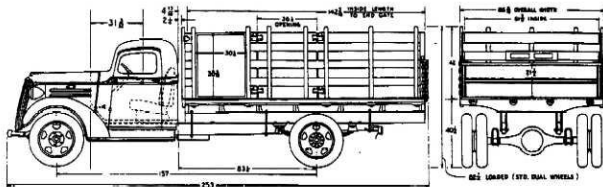

157" 1 1/2 TON  
STAKE EXPRESS

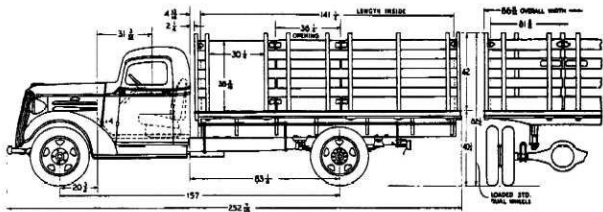

157" 1 1/2 TON STAKE

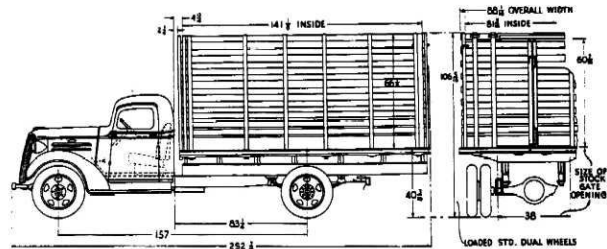

157" 1 1/2 TON STOCK RACK

## CHEVROLET 1937 SPECIFICATIONS

Supersedes Sheet No. 15 Dated 11-16-36

FRAME		PASSENGER CARS	TRUCKS		
			HALF TON	1 1/2 TON	
Type		"Box Girder"	Conventional		
Cross members		4 (3 box section, one L section) and engine rear support.	5, channel and box section.	131-1/2" WB - 5 157" WB - 6 Channel and box sections	
Overall length		160-15/16"	169-49/64"	131-1/2" WB - 185-25/64" 157" WB - 210-57/64"	
Width	at front	27-9/16"	25-45/64"⊕	25-49/64"⊕	
	at rear	44-3/8"	46"	36"⊕	
Total taper per foot		— — — —	1.694"	1.632"	
Side rail	Construction	Box section	Channel section		
	Depth	4-31/64"	5-3/4"⊕	7"⊕	
	Flange width	3-7/8"	2-1/4"⊕	2-3/8"⊕	
	Thickness	3/32" box section 5/32" double flanges	9/64"⊕	7/32"⊕	
	Section modulus	1.597 cu.in.	2.30 cu.in.⊕	4.87 cu.in.⊕	
	Kickup	front	3-5/8"	None⊕	None
		rear	6-1/16"	4"⊕	None
Material	Specification	GMC #1025 hot rolled pressed steel.⊕			
	Elastic limit	41,000 pounds per square inch.⊕			
	Elongation in 2"	35% to 40%.⊕			

⊕ Note: At spring eye centerline and outside of side rail intersection.

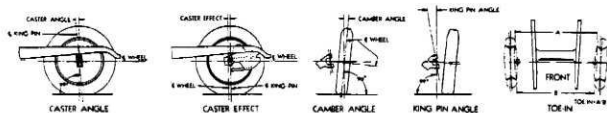

FRONT WHEEL ALIGNMENT	PASSENGER CARS		TRUCKS	
	MASTER DELUXE	MASTER	HALF TON	1 1/2 TON
King pin angle	7° 45'±	7° 10'± 1°	7° 10'± 1°	7° 10'± 1°
Camber	1/4° to 3/4°	1/2° to 1-1/2°±	1/2° to 1-1/2°±	1/2° to 1-1/2°±
Gaster	36°	26 15' ± 1/2	1° 45' ± 1/2	2° 45' ± 1/2°
Toe-in	1/16" to 3/32"±	5/64" to 1/8"±	5/64" to 1/8"±	5/64" to 1/8"±
Tread	57-17/64"±	56-3/8"±	55-3/8"±	55-1/16"
Wheel travel for steering (from neutral to stop)	37°	36°	36°	30-1/2°
Wheel setting	L.H. 4-15/16"±	Inside 23°	In 23°	In 23°
	R.H. 4-11/16"±	Outside 20°	Out 20°	Out 20°

⊕ - Caster effect at wheel of Master Deluxe (Knee action) is obtained by trailing wheel center behind center of king pin. Caster, king pin angle and camber are taken from frame with approved Chevrolet gauge with curb weight

on spindles.

Wheel setting is measured from bottom of king pin support to bottom of brake flange plate under curb load.

# CHEVROLET 1937 SPECIFICATIONS

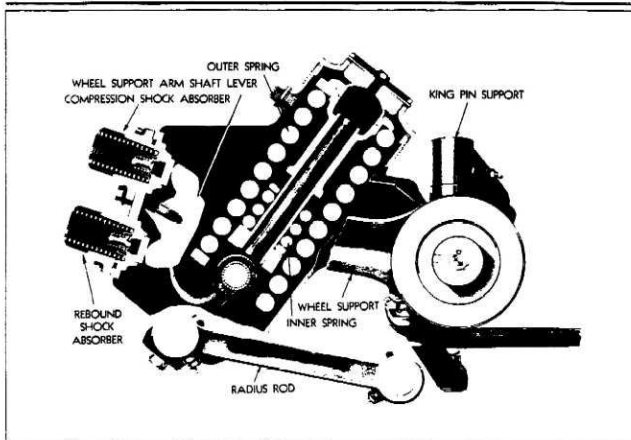

MASTER DELUXE PASSENGER CAR KNEE ACTION FRONT SUSPENSION  
DESCRIPTION WHEEL TRAVEL

At each wheel two large coil springs mounted one within the other and fully enclosed in a pressed steel housing are actuated by leverage of wheel support arm. Radius rod from unit to brake flange prevents unit from turning. Units are attached to frame king pin support member.

For steering ..... 37° from neutral to stop  
Vertical ..... 2-7/8" normal setting to bumper  
Ratio - wheel to spring ..... 3.62 to 1

Effect of wheel travel on spring pressure:  
Wheel travels on a vertical path from normal setting position 2-1/8" at the rate of 125 pounds per inch and another 23/32" at the rate of 550 pounds per inch. During the 2-1/8" wheel travel the outer spring travels 5/8" and during the 23/32" wheel travel both springs travel 1/4" at the rate of 6820 pounds per inch.

Springs	Outer	Inner
Type	Coil	
Material	Silico Manganese Steel	
Gauge (Dia.)	11/16"	7/16"
Free Length	9-11/16"	1-27/32"
Working Length	8" at 2520# Load	1-21/32" at 1000# Load
Coils, Number	11	4
Coils O.D.	3-19/32"	1-31/32"
Compression (Lbs./inch)	1520	5300

#### WHEEL SUPPORT BEARINGS

Type ..... Special rollers  
Number of rollers - Inner ..... 42  
- Outer ..... 49  
Roller - diameter ..... 3/32"  
- length, - Inner ..... 1-5/16"  
- length, - Outer ..... 31/32"

#### SPRING FREQUENCY

At curb load ..... 79 cycles per minute  
At full load ..... 76 cycles per minute

# CHEVROLET 1937 SPECIFICATIONS

MASTER DELUXE PASSENGER CAR KNEE ACTION FRONT SUSPENSION (CONTINUED)  
ARM SHAFT LEVER BEARING SPINDLE

Type ..... Special rollers\*  
Number ..... 32\*  
Roller - diameter ..... 3/32"\*  
- length ..... 51/32"\*

Attachment ..... Pressed  
into wheel support arm and peened\*  
Dia.-At inner bearing ..... 1.1890 - 1.1895\*  
-At outer bearing ..... .7490 - .7495\*

WHEEL BEARINGS

Make ..... New Departure\*  
Number - Inner ..... 909002\*  
- Outer ..... 909001\*

KING PIN BEARINGS

Type ..... Floating bushings  
Length ..... 1-5/16"

KING PIN

Diameter ..... .866"

KING PIN THRUST BEARING

Type ..... Special ball\*  
Location ..... Above knuckle\*

FRONT AXLE		PASSENGER			TRUCKS		
		MASTER		HALF TON	1 1/2 TON		
Type	Reversed Elliott modified I-beam section						
I-beam	Height	2"		2-1/8"	2-11/32"		
	Width	1-5/8"		1-3/4"	2-1/16"		
	Flange thickness (nominal)	1/4"		7/32"	5/16"		
	web	7/32"		1/4"	3/8"		
Road clearance at full load		8-5/8"		8-3/16"	10-9/16"		
King pin	Diameter	.7355"-.7340"			.9210"-.9215"		
	Material	Cold drawn steel					
King pin bushings	Type	Cast bronze		Hard rolled bronze*			
	Outside diameter	.9208-.9215		.859	1.0465"		
	Length	1-17/64"		1-17/64"	1-17/64"		
King pin thrust bearings	Type	Special ball*					
	Location	Below axle*					
Wheel bearing	Make	New Departure					
	Number-Inner	909002*		909026*			
	Number-Outer	909001*		909025*			
Spindle diameter	Inner	1.1890"-1.1895"		1.4081"-1.4056"			
	Outer	.7490"-.7495"		.8427"-.8432"			

# CHEVROLET 1937 SPECIFICATIONS

## CLUTCH

Type .....	Single dry plate	Total area-Pass. cars	
Pedal } Pass. & 1/2 TON - On brake main cyl.*		and HALF TON .....	65.87 sq.in.*
Mounting } 1/2 TON truck - On clutch housing*		1 1/2 TON Truck .....	95.72 sq.in.*
Clutch springs .....	Nine*	CLUTCH BEARINGS	
Total clutch spring pressure ....	1017 lbs.*	Throwout bearing-material ..	Carbon graphite*
Clutch rated torque capacity ...	192 ft.lbs.	Inside diameter ...	1-1/2"*
Pressure levers .....	Three*	Outside diameter ...	2-3/8"*
Clutch fork .....	Pivot mounted on ball*	Thickness .....	3/4"*
Clutch drive .....	Thru radial posts*	Thrust bearing-material .....	Cast iron*
Driving discs .....	One*	Clutch pilot bearing-make ...	New Departures*
Driven discs .....	One*	-number .....	907109*
Disc vibration insulation ..	Cushion springs	FLYWHEEL	
	at hub*	Diameter .....	13-5/16"
		Assembly weight .....	36.4 lbs.
		Material .....	Cast iron*
		Ring gear- type .....	Steel, shrunk on*
		teeth .....	139
		teeth in mating gear .....	9*
		width .....	1/2"*

## DISC FACING

Material .....	Asbestos composition*
Inside diameter .....	6-1/4"*
Thickness .....	.128" - .128"*
Outside dia.-Pass. cars and HALF TON ...	9"*
-1 1/2 TON Truck .....	10"*

STEERING	PASSENGER CARS		
	MASTER DELUXE	MASTER	TRUCKS
Type of linkage	Pore and aft*		
Type of gearing	Semi-reversible worm and ball bearing roller sector.*	Semi-reversible worm and sector*	
Gear	Ratio	17-1/2 to 1*	16 to 1
	Mainshaft dia.	3/4"*	
	Column dia.	1-1/2"*	
	Column adj.	No*	
Wheel	Type	Three spoke thin grip*	
	Material	Rubber and steel*	
	Diameter	17-5/16"*	
	Turns		
Minimum turning diameter	Right hand		
	Left hand		
Min. turning dia. within a walled circle	Right hand		
	Left hand		
Pitman arm shaft diameter	1.1255" - 1.1245"*		1.1235" - 1.1240"*

# CHEVROLET 1937 SPECIFICATIONS

SPRINGS		PASSENGER		TRUCK	
GENERAL DATA		MASTER-FRONT	ALL-REAR	1/2 TON REAR	1 1/2 TON REAR
Type	Semi-elliptic*				
Material	Chrome Vanadium 1 1/2 TON front only*				Silico manganese steel*
Type of leaf ends	Tapered*		Curled down*		Flat*
	SDL-curved down		1 1/2 TON front flat		
Shackle	Location	At rear*		At front*	At rear*
	Type	Threaded*			Plain*
Shackle Pins	Material	Cold drawn steel*			
	Diameter	21/32", 11 threads per inch. Ends taper from 9/16" dia. down at rate of 1-1/2 inches per foot.*			
Spring Eye Bolt	Material	Cold drawn steel*	Harden steel*	Cold drawn steel*	
	Diameter	11/16"*	1/2"*	11/16"*	7/8"*
	Type	Threaded for eye bushings*	Inlox; rubber and steel bushing*	Plain*	
Front Bushing	Material	Cold drawn steel*			Bronze*
	Diameter	7/8 O.D.*	1/2 I.D.*	7/8 O.D.*	1-9/64 O.D.
	Length	1-3/4"*	2.408*	1-3/4"	2-1/2"
	Housing				
	Mat'l. O.D. Length	None*	Steel 1-5/32" Dia.* 2"	None*	
Rear Bushing	Type	Harden for shackle pin*	Plain*	Threaded for shackle pin*	Plain*
	Material	Cold drawn steel*		Bronze*	Cold drawn steel*
	O.D.	7/8"*			1-9/64"*
	Length	1-3/4"			2-1/2"
Spring attachment to axle	2 U Bolts per spring*				
Spring U bolt	Material	Hot rolled steel*			
	Diameter	1/2"*			
Spring bumper	Solid rubber				
Spring covers	None*	Sheet metal D:AS*	None*		
Spring mounting	Parallel*		6°4'(1/2 TON) 7°49'(1 1/2 TON) included angle	8°4' included angle	Parallel*
Distance between spring centers	42-5/16 DNAS 28-1/8 MASTER	44-11/16"	28-15/16"	42-1/2"	42"*

# CHEVROLET 1937 SPECIFICATIONS

PASSENGER CAR SPRINGS	MASTER DELUXE				MASTER			
	Rear		Front		Rear			
	All but Bus, Cpe & Spt.Cpe	Bus. Spt. Cpe Cpe	Pass. Cars	Sedan Deliv.	All but Cpe,Sed. Del. & Cabriolet	Cabriolet & Bus. Coupe	Sedan Deliv.	
Number of leaves	8	7	9		8			
Gauge of leaf #1	.238"	.238"	.203"	.258"	.238"	.238"	.259"	
2	.238"	.238"	.203"	.238"	.238"	.238"	.259"	
3	.238"	.220"	.220"	.238"	.238"	.220"	.238"	
4	.238"	.220"	.220"	.220"	.238"	.220"	.238"	
5	.238"	.220"	.203"	.220"	.238"	.220"	.238"	
6	.220"	.220"	.203"	.220"	.220"	.220"	.238"	
7	.220"	.220"	.203"	.220"	.220"	.220"	.238"	
8	.220"	-	.203"	.220"	.220"	-	.238"	
9	-	-	.220"	-	-	-	-	
Total thickness	1.850"	1.876"	1.878"	1.814"	1.850"	1.676"	1.948"	
Spring length	49"		36"		49"			
Width	1-3/4"							
Working height	1/16"		7/16"		1/16"			
Load at working height	900# to 1000#	715# to 785#	580# to 640#		900# to 1000#	715# to 785#	1000# to 1100#	
Deflection	129#/"	105#/"	235#/"		129#/"	105#/"	150#/"	
Frequency (cycles per minute)								
At curb load								
At full load								

TRUCK SPRINGS	HALF TON		1 1/2 TON				
	Front	Rear	Front	All except UPAN			UPAN
				Rear	Auxiliary <sup>2</sup>	Both	Rear
Number of leaves	8 <sup>2</sup>		9 <sup>2</sup>	10 <sup>2</sup>	8 <sup>2</sup>	16 <sup>2</sup>	8 <sup>2</sup>
Gauge of leaf #1	.284"	.300"	.340"	.340"	.340"	-	.312"
2	.284"	.300"	.284"	.340"	.340"	-	.312"
3	.259"	.300"	.284"	.340"	.340"	-	.312"
4	.259"	.300"	.284"	.340"	.340"	-	.312"
5	.259"	.300"	.259"	.340"	.340"	-	.284"
6	.259"	.300"	.259"	.340"	.340"	-	.284"
7	.259"	.300"	.259"	.3125"	-	-	.284"
8	.259"	.300"	.259"	.3125"	-	-	.284"
9	-	-	.259"	.3125"	-	-	-
10	-	-	-	.3125"	-	-	-
Total thickness	2.122"	2.400"	2.487"	3.290"	2.040"	3.330"	2.384"
Length	36"	54-1/8"	36"	48"	31-1/2"	-	48"
Width	1-3/4"		2-1/2"				
Working height	3/16"	7/16"	23/32"	7/16"	-	-	1"
Load at working height	710# to 790#	1100# to 1200#	900# to 1000#	2800# to 3100#	-	-	1425# to 1575#
Deflection rate	475#/"	200#/"	645#/"	840#/"	1610#/"	-	490#/"

<sup>2</sup> - Auxiliary springs engage at load of 1700# each.

# CHEVROLET 1937 SPECIFICATIONS

Supersedes Sheet No. 21 Dated 11-18-35

## SHOCK ABSORBERS

MASTER DELUXE		MASTER AND HALF TON		
	FRONT	REAR	FRONT	REAR
Make	Delco Products Company (Hydraulic)*			
Type	Double acting*	Single acting*	Single acting*	
Valve Code Numbers	1B (Compression) 1B (Rebound)	2BE	5G MASTER 4CG HALF TON	5G MASTER 3CG HALF TON

TRANSMISSION		PASSENGER CARS AND HALF TON TRUCK		1 1/2 TON TRUCK
Type		Selective synchromesh, silent second*		Conventional selective*
Shift type		Standard*		
Number of speeds		3 forward 1 reverse*		4 forward 1 reverse*
Constant mesh gears type		Helical*		Spur*
Synchromesh gears		Second and third*		None*
Transmission location		In unit with engine*		
Torque capacity (ft.lb.)		192		
Reverse	Number	Two*		
Idler	Inside diameter	.7515-.7525		.876 - .877*
Bearings	Length	3/4"		1-1/2**
	Material	Rolled bronze		Rolled brass*
Mainshaft Bearing	Make	Front-Hyatt Rear-New Departure		
	Number Front	590782		
	Number Rear	954168		
Counter Shaft Bearings	Material	Rolled bronze		
	Make	Chevrolet		
	Size or no. Front	.8875 I.D. - 1.008 O.D. x 1-1/4" long*		142260*
	Size or no. Rear	.8875 I.D. - 1.008 O.D. x 1-1/4" long		121856*
Clutch	Make	New Departure*		
Gear Brg.	Number	954141		903209*
2nd. Speed Gear	Outside diameter	1.060-1.061		- -
	Length	1-3/4"		- -
Bearing	Material	Copper plated surface		
	NODELS	DHAS	MASTER	HALF TON
Speedometer gear ratios		3.166 to 1	2.8 to 1	3 to 1* (2.8 - 1 opt)
Power take-off		None*		6 bolt S.A.E. Std. **
Gear Ratios	First	2.94		7.226*
	Second	1.68		3.478*
	Third	Direct		1.711*
	Fourth	None		Direct*
	Reverse	2.94		7.148*
Maximum Torque of gear set (ft.lbs.)	First speed	474**		1172**
	Second speed	271**		561**
	Third speed	170		276**
	Fourth speed	- -		170
	Reverse	474**		1152**

\* - Power take-off on left side; at 1000 engine RPM, the 33 tooth gear meshing meshing with take off is running 425 RPM.

\*\* - 95% efficiency assumed.



# CHEVROLET 1937 SPECIFICATIONS

Supersedes Sheet No. 22 Dated 11-18-36

REAR AXLE		PASSENGER CARS		TRUCKS		
		MASTER DELUXE	MASTER	1/2 TON	1 1/2 TON	
Type		Semi-floating*		Full-floating*		
Gross Rating		3000#	3000#	3300#	9800#	
Housing		Pressed steel banjos*			Seamless tubular steel banjo	
Final Drive Type		Hypoid gear		Spiral bevel gear		
Gear Ratio		4.222	3.727	4.111* (3.818 opt.)*	5.429* (5.166 opt.)*	
Ring Gear Teeth		38	41	37* (42)*	38* (37)*	
Pinion Teeth		9	11	9* (11)*	7* (8)*	
Gear Backlash		.005" to .007"		.005" to .010"		
Pinion Mounting		Overhung*			Straddle*	
	Adjustment	Shims and tapered collars*			None*	
Pinion Shaft	Front Bearing	905306		905206*		
	Number	905306		905309*		
	Rear Bearing	Hyatt*		New Departure*		
	Number	125630*		901305*		
Thrust	Against front pinion bearings*					
Differential Type		Two pinions*		Four pinions*		
Side Bearing	Make	Hyatt		New Departure*		
Number		127861		902100*		
Wheel Bearing	Make	Hyatt*		954186		
Number		111103		111104*		
				Inner 144527 Outer 144525		
Axle Shaft	Type	Wheel end upset*			Drive flange forged*	
	Material	H.R. Steel G.M.C. X 3140-A*				
	Normal Dia.	31/32"		1-1/16"		
				1-7/16"		
Minimum Road Clearance (Loaded)		8-1/2"		8"		
				8-5/8"		
Tread		57-9/16"		59-1/4"		
				58-17/32" Single 66-1/32" Dual (Mean) 73-17/32" Dual (Outer)		
Drive Torque		Thru torque tubes				
Total	First speed	12.407	10.966	12.083	39.22*	44.56*
Gear	Second speed	7.089	5.266	6.905	18.88*	21.45*
Reductions	Third speed	4.222	3.727	4.111	9.29*	10.55*
	Fourth speed	- -	- -	- -	5.428*	6.166*
	Reverse	12.407	10.966	12.083	38.80*	44.07*

Axle Shaft Torque (ft. lb.)	First speed	1792	1585	1745	5665	6435
	Second speed	1023	905	998	2725	3098
	Third speed	610	538	595	1541	1522
	Fourth speed	- -	- -	- -	784	890
85% eff.	Reverse	1792	1585	1745	5606	6370

Axle shaft torque (ft. lbs.) using optional gear ratios (1/2 TON)						
	3-speed transmission			4 speed transmission		
	Gear Ratio	Torque	Gear Ratio	Torque	Gear Ratio	Torque
First speed	11.22	1021	27.0	2061*	29.7	2061*
Second speed	6.42	928	13.27	1015	14.28	2061*
Third speed	3.82	552	6.54	944	7.04	1015
Fourth speed	- -	- -	3.32	552	4.111	894
Reverse	11.22	1021	27.25	2061*	29.35	2061*

\* - Maximum allowable torque for both axles.

# CHEVROLET 1937 SPECIFICATIONS

UNIVERSAL JOINTS		PASSENGER CARS AND HALF TON TRUCKS		1 1/2 TON TRUCKS	
				Front Joint	Rear Joint
Location		End of transmission*			Connects front and rear propeller shafts*
Type		Steel yoke and rings*		Steel yoke and spider*	
Yokes	Material	DF nickel chromium steel*		DF carbon steel*	
	Pin diameter	.6865"-.6875*		.716"-.717*	
Bearings	Length	5/8"		.708"-.728"	
	Number	Four*			
	Distance between pin bearing centers	2-3/4**		2-15/16**	
	Clearance, on diameter, between pin and bearing.	.002"-.005**		.001"-.003**	
Type of ends		Splined*			
Front Yoke	Number	10		10*	
	Inside diameter	.849 - .857"		1.184 - 1.186*	
Splines	Outside diameter	.985"-.993"		1.380 - 1.388*	
	Number	10*			
Rear Yoke	Inside diameter	.907"-.915**		1.1145 - 1.1195*	
	Outside diameter	1.057"-1.065**		1.306 - 1.321*	
Lubrication		Self, from transmission*			Self, from front shaft; plus pressure type fitting*

PROPELLER SHAFT	PASSENGER CARS			TRUCKS	
	MASTER DELUXE	MASTER	HALF TON	1 1/2 TON	
Type	Tubular*			Solid*	
Material	Nickel-chromium steel ends; carbon steel tube*				Nickel chromium steel*
Number used	One*			Two, for split shaft power take-off*	
Type of ends	Splined*				
Splines at ends	10*				
Shaft length	59-1/4"		58-29/64"	Front- 131-1/2" W.B., 22-7/8" 157" W.B. -17/64" Rear- 53-11/64**	
Connection to pinion shaft	Splined sleeve held by rivets				

# CHEVROLET 1937 SPECIFICATIONS

BRAKES		MASTER DELUXE AND MASTER		TRUCKS	
		1/2 TON		1 1/2 TON	
Service Type		Hydraulic 4 wheel, internal expanding, articulated shoe*			
Brake Drum	Diameter	11"		14" front* 16" rear*	
	Type	Composite; cast iron rim with cooling ribs; prestressed steel web*		Steel stamping*	
Lining	Width	1-3/4"		2" front* 3" rear*	
	Thickness	.137-.194*		.243 - .250*	
	Total effective area	168-1/4 sq.in.*		330.2 sq.in.*	
	Clearance	Adjust to slight drag; back off 4 notches*		Adjust to slight drag. Front, back off 4 notches. Rear, 2/3 screw turn*	
	Material	DMAS full moulded. All others semi-moulded.			
Main Cylinder	Diameter	1"	1"	1-1/4"	
	Piston travel for full pedal stroke	1-5/16"	1-5/16"	1.267"	
Wheel Cylinder	Diameter - front	1-1/4"	1-1/4"	1-1/4"	
	Diameter - rear	1-3/16"	1-3/16"	1-1/2"	
	Piston travel for full pedal stroke	.110"		.130"	
Braking pressure	Front	52-1/2%*	52-1/2%*	30.7%*	
	Rear	47-1/2%*	47-1/2%*	69.3%*	
Pedal ratio		4.83 to 1*	5.03 to 1*	6.167 to 1*	
Hydraulic ratio		11.89 to 1*	11.89 to 1*	9.759 to 1*	
Average overall ratio pedal movement to brake shoe movement		57.40 to 1*	59.9 to 1*	50 to 1*	
Pedal travel		5-11/32"	6-1/8"	7-3/8"	
Pedal mounting		With main cylinder to frame*		On clutch housing*	
Pedal pads		DMAS: Rubber* - All others steel*			
Hand brakes-type		Cut-in system on 2 rear service brakes actuated mechanically and entirely separate from Hydraulic system. Pull rods and cables operate two shoes in each brake thru toggle linkage*			
Brake area (hand)		76-1/8 sq.in.*		214.0 sq.in.*	
Lever mounting		To frame*		To transmission*	
Brake system capacity		3/4 pint approximately*			
Fluid recommended		Above zero		Below zero	
				-10°	
				-20°	
		30°		-30°	
				Consistently -10°	
				Delco No.	
				#5*	
				#6*	
				#3*	
				#1*	

# CHEVROLET 1937 SPECIFICATIONS

ENGINE PERFORMANCE		PASSENGER CARS		TRUCK	
				HALF TON	1 1/2 TON
Horse- Power	Rated (SAE)	29.4			
	Max. BHP (Adv.)	85 at 3200 RPM		78 @ 3200 RPM	
	Per cu.in. displacement	.393		.360	
	Max. engine speed (adv.)	4000 RPM			
	Max. torque (advertised)	170 ft.lbs.at 900 to 2000 RPM		170 ft.lbs. 850 to 1550	
	Max. BMEP @ 60 F (Less accessories)	116 @ 800 RPM			
Compression	Nominal	152# @ 1000 RPM-159# @ 2000 RPM			
Pressure	At cranking RPM	112# @ 65 RPM			
Piston	Displacement	216.6 cu.in.			
Displace- ment	Per ton mile (cu.ft.)@	113	103.2	87.25	56
	Per vehicle mile (cu.ft.)@	197.0	174.2	191.9	212.5
	Gross weight for computations@	3480#	3370#	4400	7600
	Coach weight per cu.in.	16.08#	15.57#	- - -	- - -
	Engine RPM per MPH	52.42	46.28	51.05	56.55
	Engine revs. per mile in high gear	3145	2777	3063	3393
	Piston travel per mile in high gear	1960 ft.	1735 ft.	1915 ft.	2115 ft.
	Axle ratios for above computations	4.222	3.727	4.111*	5.422*
	Tire size for above computations	5.00-16 - 4 ply			32 x 6 - 8 ply*
Engine and Power Plant Weights-Dry	Engine complete (Eng., trans. and lever)	557#	562#	566#	

\* Note - Passenger car weights are based on weight of Coach, Curb weight, plus 450# for Pass.

## GENERAL

Type ..... Valve-in-heads  
 Number of cylinders ..... Six  
 Cylinder arrangement .. In line cast-en-block  
 Bore ..... 3-1/2"  
 Stroke ..... 3-3/4"  
 Compression ratio ..... 6.25 : 1  
 Manifold heat control ..... Thermostatic

## CYLINDER HEAD

Type ..... Detachable  
 Material ..... Cast iron  
 Combustion chamber design .... "Blue Flame"

## PISTONS

Type ..... Slipper skirt, dome head  
 Material ..... Cast iron-tin plated  
 Length ..... 4-1/64"  
 Pin center to top of head ..... 2-15/64"  
 Distance between pin bosses ..... 1-9/32"  
 Compression ring groove depth .. .150"-.162"  
 Clearance on dia.-Top land, 2nd land and 3rd  
 land-.0145"-.019" cold

Clearance on dia.-skirt .. .0015"-.003" cold  
 Oil ring groove depth ..... .173"-.183"  
 Oil ring groove holes ..... 5/32" drill, 1/4  
 holes equally spaced  
 Side wall thickness ..... .0395"-.049"  
 Head thickness ..... .165"-.167"  
 Piston pin bushings- .... Pressed in piston  
 -material ..... Bronze  
 -O.D. .... .953"-.964"  
 -length (each)... 15/16"  
 -finish .... Diamond bore  
 -weight (each) ... .045#  
 Piston wt. without bushings ..... 1.42#  
 Total reciprocating weight:  
 Weight of piston, bushings, rings, pin and  
 connecting rod upper end x 6 ..... 14.16#

## PISTON PINS

Diameter (Plated) ..... .8645"-.8650"  
 Length ..... 3-3/32"  
 Taper and diameter limits ..... .0003"  
 Weight (each) ..... .29#  
 Clearance in bushing ..... Slip fit

# CHEVROLET 1937 SPECIFICATIONS

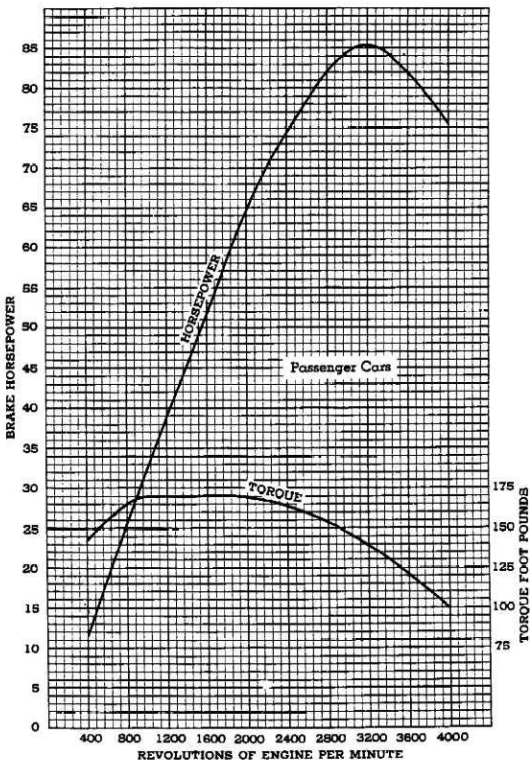

POWER AND TORQUE

# CHEVROLET 1937 SPECIFICATIONS

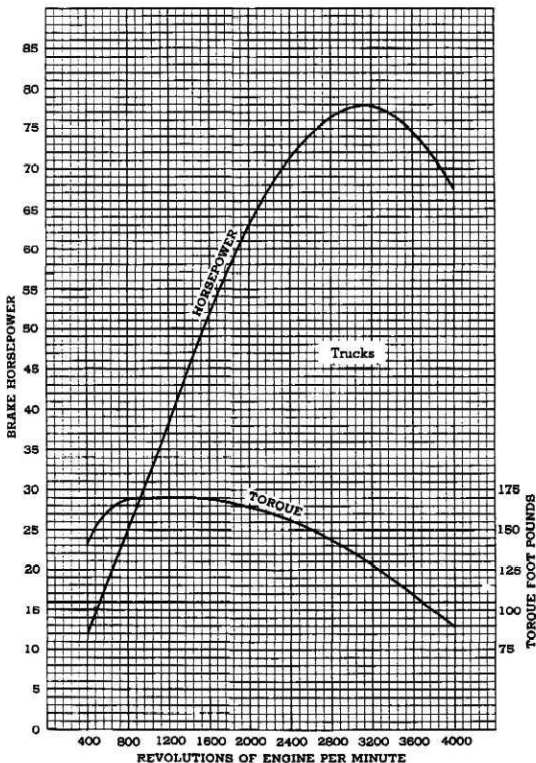

POWER AND TORQUE

# CHEVROLET 1937 SPECIFICATIONS

PISTON RINGS		COMPRESSION	OIL CONTROL
Number and location		3 above piston pin*	
Material		Cast iron*	
Type		Plain*	Drilled or slotted*
Number		2*	1*
Arrangement		Upper two rings*	Under compression rings*
Width		.1235"-.1240"*	.1860"-.1865"*
Wall thickness		.155" max.	.155" max.
Gap clearance		.005"-.015"*	.005"-.015"*
Ring clearance in groove		.0015"-.003"*	.002"-.0035"*
Weight (each)		.05 lbs.	.06 lbs.

## CONNECTING RODS

Type .....	Pin clamped in rods	Lower end brg. area-	
Material .....	Drop-forged carbon steel	Projected .....	18.39 sq.in.
Length (center to center) .....	6-13/16"	Circumferential .....	87.7 sq.in.
Crank pin diameter .....	2.311"-2.312"	Shims-type .....	Solid*
Crank pin length .....	1.4985"-1.5015"*	-material .....	Brass
Width at piston pin .....	1-1/8"	Wt. conn.rod assy. (each) .....	1.77#
Lower end brg.-type ....	Centrifugally cast*	Upper end (each) .....	.4#
-diameter ....	2.3138"-2.3138"	Lower end (each) .....	1.37#
-length .....	1-5/16"	Total rotating weight (lower end x 6)	8.22#
-material .....	Babbitt*	Conn.rod assembly center of gravity:-	
-finish .....	Diamond bore	5.273" from wrist pin center	
-clearance on dia-.001"-.0025"		Conn.rod end play .....	.0065"-.0135"

VALVES		INLET	EXHAUST
Material		Extruded steel*	
Head diameter		1-41/64"*	1-15/32"*
Length		6.057" - 6.087"*	4.759" - 4.819"*
Stem	Diameter	.3407" - .3417"*	.3397" - .3407"*
	End style	Grooved for cup and cone*	
Spring	Valve closed	42 to 48 lbs.*	
Pressure	Valve open	94 to 102 lbs.*	
Lift		.305"	.3195"
Valve	Type	Removable*	
Stem	Diameter	.3427" - .3437"*	
Guide	Clearance with stem	.001" - .003"*	.002" - .004"*
Valve face angle		30° *	
Valve	Material	Cast iron*	
Seat	Cooling	Jets of water in cylinder head directed under pressure to valve seats.*	
Grinding tool clearance.		1-13/16" max dia.cutter*	1-17/32" max.dia.cutter*





# CHEVROLET 1937 SPECIFICATIONS

Supersedes Sheet No. 30 Dated 11-18-36

## COOLING SYSTEM (All models)

Capacity ..... 14 quarts

## WATER PUMP

Type ..... Centrifugale  
Location ..... On front of engine  
Capacity ..... 47 gals. per min. @ 4000 RPM  
Impeller type ..... Vane  
Drive ..... By fan belts  
Shaft forward bushing-material ..... Copper-graphite composition  
Bushing size .. .6145"-.6155" I.D. x 13/16"  
Shaft rear bushing-material ..... Copper-graphite composition  
Bushing size .. .6145"-.6155" I.D. x 23/32"  
Packing-material ..... Impregnated duck  
-adjustment ..... By spring tension

## RADIATOR CORE

Make ..... Harrison\*  
Type ..... Ribbed cellulare  
Material ..... All copper\*  
Size-Pass.cars .... DIAS.-.222" x .556" x 2"  
                                  MASTER-.25" x .556" x 2"  
-Trucks ..... .25" x .560" x 2"  
Exposed core area-Pass.cars ... 368.5 sq.in.  
                                  -Trucks ..... 405 sq.in.

## RADIATOR HOSE

Inlet hose-location .... From cylinder head to core

Inlet hose -inside diameter ..... 1-1/4"  
                                  -length, passenger cars .. 5-5/8"  
                                  -length, trucks ..... 6-1/4"  
Outlet hose-type ..... Two pieces connected by steel tube\*  
                                  -location ... Core to water pump\*  
                                  -inside diameter ..... 1-1/2"  
                                  -length, upper hose ..... 2-3/4"  
                                  -length, lower hose ..... 5"

## WATER THERMOSTAT

Make ..... Harrison\*  
Type ..... Bellows operating poppet valve\*  
Valve starts to open at 140° - 145° F.water\*  
Valve fully open at 170° F. still water and 29.92" Hg. barometric pressure  
Location ..... In cylinder head outlet

## ENGINE FAN

Number of blades ..... 4, staggered  
Diameter-Deluxe Master ..... 15-3/4"  
                                  -Trucks & Master pass. .... 16-1/4"  
Pulley-type ..... V\*  
-angle of V ..... 28° e  
-diameter ..... 4-21/64"  
Ratio of fan to engine speed ..... 1.393\*  
Clearance between fan and core ..... 9-16"  
Fan belt-make ..... Various\*  
-material ..... One-piece vulcanized fabric\*  
-length around outside ..... 42-7/8"  
-maximum width ..... 11/16"

## ENGINE MOUNTINGS

### CUSHION BALANCED RUBBER

#### PASSENGER CARS

5 point

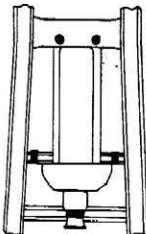

#### HALF TON TRUCK

4 point

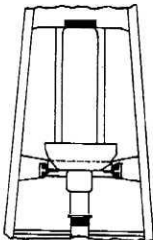

#### 1 1/2 TON TRUCK

3 point

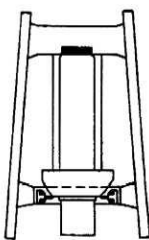

# CHEVROLET 1937 SPECIFICATIONS

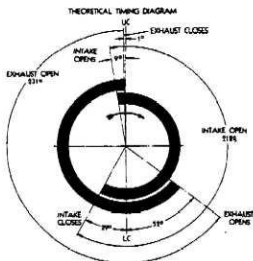

### FUEL PUMP

Make ..... AC®  
 Model ..... AF  
 Type ..... Mechanical®  
 Drive ..... By camshaft®  
 Arm throw at camshaft ..... 1/4"®  
 Inlet and outlet air dome ..... Yes  
 Fuel filter ..... Screen on dome®

### FUEL GAUGE

Make ..... AC®  
 Type ..... Electric®

### CARBURETOR

Make ..... Carter®  
 Type ..... Single adj. down-draft®  
 Model ..... WI-346-S  
 Size ..... 1-1/4"®  
 Accelerator pump ..... Yes®  
 Float level ..... When closed, top of float measures 3/8" below finished surface of cover.®

### AIR CLEANER

Make ..... AC®  
 Type ..... Combined with silencer and flame arrester.®

Fuel mixture heated ..... Yes- Passes thru manifold heat chamber, automatically controlled by thermostat on manifold.®  
 Octane selector ..... Yes®

EXHAUST SYSTEM	PASSENGER CARS	TRUCKS
Muffler Type	Diffusion & resonance (5-tube reverse flow)	Baffle®
Diameter	6-1/16"®	5"®
Length	18"	20-1/2"®
Mounting	Single pt. rubber®	Single pt.®
Exhaust Pipe Dia.	1-7/8"	
Tail Pipe Diameter	1-3/4"®	1-1/2"®

FUEL TANK	PASSENGER CARS	TRUCKS	
		1/2 TON	1 1/2 TON
Capacity (gallons)	14®	18	18
Location	Bus. Coupe 18 At rear of chassis; in underload- ing floor.	Panel 168 At center of chassis next to R.H. side rail.	Under seat®
Type	2 stamped pans welded together®		

### ENGINE LUBRICATION

Type ..... Pressure, pressure stream and splash®  
 Oil pump-type ..... Gear-drive ..... From camshaft  
 Main brg. lubrication ..... Direct pressure®  
 Oil is pumped thru drilled passages in cylinder case directly to main bearings  
 Camshaft brg. lubrication ... Direct pressure thru passages from main bearings®  
 Timing gear lubrication ..... Gravity feed from camshaft front bearing overflow.®  
 Connecting rod brg. lubrication .. By dippers at low speeds. By pressure stream at high®  
 Cylinder bore lubrication ..... Splash®  
 Wrist pin lubrication ..... Splash®  
 Valve rocker mechanism lubrication:-  
 Pressure. Oil pipe from low pressure side of oil distributor carries oil to valve rocker arms, springs, valve stems and upper ends of push rods®  
 Oil pressure gauge ..... AC®  
 Oil cleaner type ..... Screen with by-pass on intake side of oil pump®  
 Oil drain type ..... Plug in side of oil pan®  
 Crankcase ventilator type ..... Suction®  
 Oil filler ..... Combined with ventilator®  
 Oil screen area ..... 19.3 sq. in.  
 Oil level gauge type ..... Rod®  
 Oil pan-capacity (dry) ..... 3-1/2 quarts®  
 -capacity (for refill) .... 5 quarts®

## ENGINE RPM AND PISTON SPEED CHARTS

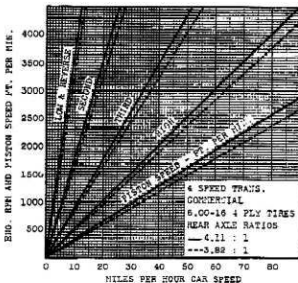
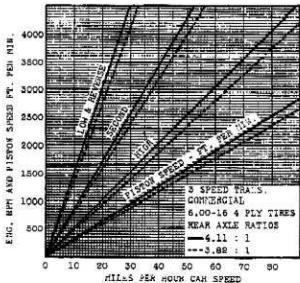
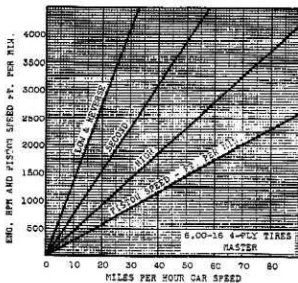
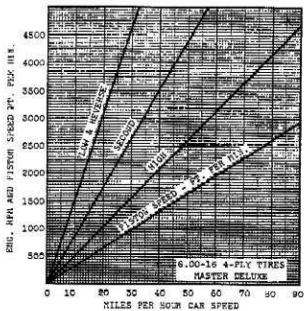

# CHEVROLET 1937 SPECIFICATIONS

ENGINE RPM AND PISTON SPEED CHARTS - CONTINUED

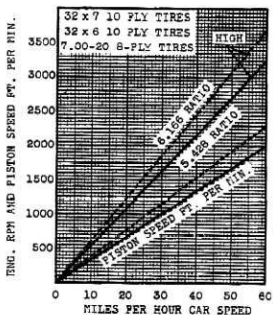
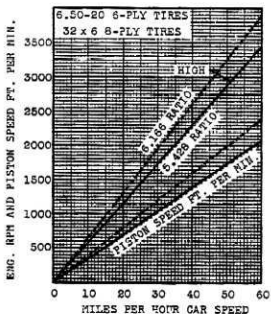
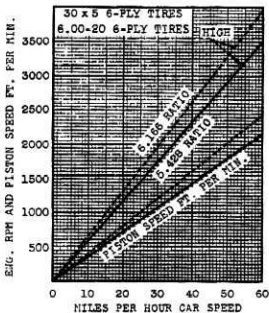

## CHEVROLET 1937 SPECIFICATIONS

Supersedes Sheet No. 34 Dated 11-18-36

TIRES AND WHEELS		PASSENGER CARS AND HALF TON TRUCK	1 1/2 TON TRUCK
R I S  T I R E S	Wheels type	Steel, short spoke disc type	Pierced disc <sup>o</sup>
	Type	Drop center, integral with wheel <sup>c</sup>	Integral with wheel; separate lock ring <sup>o</sup>
	Base (Regular tires)	4.00E	5" Flat base <sup>o</sup> E
	Make	United States or Goodrich <sup>o</sup>	
	Size of Regular tires @	6.00-16, 4 ply	6.00-20, 6 ply <sup>o</sup> front and dual rear tires. @ 32 x 6, 8 ply <sup>o</sup> single rear. @
	Recommended pressure	Minimum 26# front 28# rear @	See tire ratings 1 1/2 TON Trucks below
	Load rating	875# front 915# rear	
	Revs. per mile	746	
	Loaded radius	13.5"	

@ - On HALF TON Truck carry 28# pressure in front tires, 32# in rear tires, with 900# rating per rear tire.

@ - See Truck Tire options on next page.

TIRE OPTIONS - HALF TON TRUCK						
SIZE AND PLY	Make	Pressure	Revs. per mile	Load Rating	Wheel Type	Rim Base
6.00-16 6 ply	U.S. or Goodrich	30# front 40# rear	745	955# front 1130# rear	Short spoke steel disc type	4.00E
15" (7.50-15) 6 ply		15-20# front 15-35# rear		733 <sup>o</sup>		950-1500#
5.50-18, 4 ply		24# front 32# rear	707	1050# rear		3.62 F.

TIRE RATINGS - 1 1/2 TON TRUCKS						
SIZE	Pressure	Load Rating	Rolling Loaded Radius	Revs./mile	Weight tire Tube & Wheel	
30 x 5 - 6 ply	70 lbs. <sup>o</sup>	1600 lbs. <sup>o</sup>	15.583	643 <sup>o</sup>	85#	
6.00-20 - 6 ply	45 lbs. <sup>o</sup>	1400 lbs. <sup>o</sup>	15.683	643 <sup>o</sup>	85#	
32 x 6 - 8 ply	75 lbs. <sup>o</sup>	1950 lbs. <sup>o</sup>	16.135	625 <sup>o</sup>	100#	
6.50-20 - 6 ply	50 lbs. <sup>o</sup>	1700 lbs. <sup>o</sup>	16.135	625 <sup>o</sup>	90#	
32 x 6 - 10 ply	80 lbs. <sup>o</sup>	2200 lbs. <sup>o</sup>	16.807	600 <sup>o</sup>	125#	
7.00-20 - 8 ply	55 lbs. <sup>o</sup>	1950 lbs. <sup>o</sup>	16.807	600 <sup>o</sup>	110#	
32 x 7 - 10 ply	85 lbs. <sup>o</sup>	2550 lbs. <sup>o</sup>	16.807	600 <sup>o</sup>	135#	

# CHEVROLET 1937 SPECIFICATIONS

TIRE OPTIONS - 1 1/2 TON TRUCKS

REAR TIRES Sizes and option numbers	FRONT TIRES - Sizes and option numbers						
	6.00-20, 6 ply, 5" rim. 3-3/4" offset wheel Reg. equip.	6.50-20, 6 ply, 5" rim. 4-1/8" offset wheel Opt. 215	7.00-20, 8 ply, 6" rim. 4-1/2" offset wheel Opt. 218	30 x 5, 6 ply 5"rim.3-3/4" offset wheel Opt. 203	32 x 6, 8 ply 5"rim.3-3/4" offset wheel Opt. 207	32 x 6.10 ply 6"rim.4-1/2" offset wheel Opt. 210	32 x 6.8 ply 5"rim.4-1/8" offset wheel Opt. 206
32 x 6, 8 ply 5" rim. 3-3/4" offset wheel. Regular eqpt.*	X *			X	X		
32 x 6, 10 ply 6" rim. 4-1/2" offset wheel. Opt. 211	X	X	X	X		X	X
6.50-20, 6 ply 5" rim. 4-1/8" offset wheel. Opt. 216	X	X					
7.00-20, 8 ply 6" rim. 4-1/2" offset wheel. Opt. 219	X	X	X				
32 x 7, 10 ply 7" rim. 2-3/8" offset wheel. Opt. 213	X	X	X	X		X	X
6.00-20, 6 ply 5" rim. 3-3/4" offset wheel. Opt. 214 @	X						
6.00-20, 6 ply 5" rim. 3-3/4" offset wheels. Regular eqpt.*	X *						
30 x 5, 6 ply 5" rim. 3-3/4" offset wheels. Opt. 204				X			
32 x 6, 8 ply 5" rim. 4-1/8" offset wheels. Opt. 209	X			X			X
32 x 6, 10 ply 6" rim. 4-1/2" offset wheels. Opt. 212-193 @	X	X	X	X		X	X
6.50-20, 6 ply 5" rim. 4-1/8" offset wheels. Opt. 217	X	X					
7.00-20, 8 ply 6" rim. 4-1/2" offset wheels@ Opt. 220	X	X	X				

@ Panel job only with light rear springs. (1 ton).

@@ Auxiliary springs (Opt. 103) must be used with Opt. 212.

Never use a larger tire in front than in rear nor high pressure tires in front with balloon rears.

## CHEVROLET 1937 SPECIFICATIONS

ELECTRICAL SYSTEM				
GENERATOR	PASSENGER CARS			TRUCKS
	MASTER DELUXE	MASTER	1/2 TON	1 1/2 TON
Make	Delco-Remy®			
Model	948-R			
Ventilated by	Fan built into generator pulley®			
Driven by	"V" belts			
Generator pulley	Type	28° V's		
	Diameter	3-11/32"		
Speed ratio-generator to engine	1.80 : 1*			
Amperes -cold	Lights off	15		
	Lights on	18-21		
Max. charging rate-cold	Voltage	8.2		
	RPM	2600		
Car speed	26 M.P.H.	30.6 M.P.H.	27.8 M.P.H.	24.1 M.P.H.
Amperes -hot	Lights off	14		
	Lights on	15-18		
Max. charging rate-hot	Voltage	8.1		
	RPM	2800		
Car speed	29.2 M.P.H.	33 M.P.H.	30 M.P.H.	26 M.P.H.
Thermostat	None®			
Field fuse	None®			
Voltage regulation	None			
Rated voltage	6-8*			
Brush tension	14-18 oz.*			
Rotation (Drive end)	Clockwise®			
Bearings	Commutator end	Bronze Bushings		
	Drive end	Ball®		
Cut-out	Voltage at closing	7.2		
	Armature speed	800 R.P.M.		
	Car speed at closing	8.3 M.P.H.	9.4 M.P.H.	8.5 M.P.H. 7.8 M.P.H.
	Amperes to open	1.5*		
<b>IGNITION</b>				
Type	Separate units, high tension dist. ground return system®			
Make	Delco-Remy®			
Model No.	649-G			
Ignition lock-Type	Armored cable from coil to dash and lock switch			
Current source	Generator®			
Spark control-Type	Full automatic®			
Octane selector adjustment	20° Vernier manual®			
Advance	17° Vacuum® - 42°-50° Automatic			
Firing order	1-6-3-6-2-4*			
Timing spark advance	5° S.T.C.*			
Dist. interrupter point opening	.019"-.024"			
Dist. bearings	Cast iron®			
Condenser-make	Delco-Remy®			
Coil Location	On right side of engine®			
	Amps. Engine stopped	4.8*		
Drawn	Engine idling	2.5*		
Spark plug	Make	AC®		
	Size	K-11 Metric®		
	Recommended gap	.040"		

# CHEVROLET 1937 SPECIFICATIONS

SPARK ADVANCE CURVE

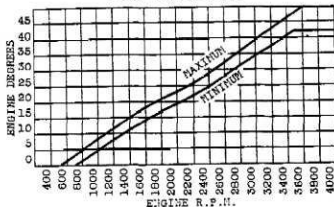

BATTERY	PASSENGER CARS		TRUCKS	
	MASTER DELUXE	MASTER	1/2 TON	1 1/2 TON
Make	Delco*			
Model	17M		15*	
Number of plates	17		15*	
Length	10-9/16"		8-15/16"	
Width			7*	
Height	7-7/16"		8-9/16"	
Volts			6*	
Ampere hours capacity	100		94	
Cell arrangement	3 - Side to side*			
Shipped wet or dry	Optionale*			
Charging rate	Start		6*	
	Finish		5*	
Terminal grounded	Negative*			
Battery mounted to	Frame-Right side*			
<b>STARTING MOTOR</b>				
Make and Model	Delco-Remy*, 739A			
Type of drive	Bendix*			
Lock test	Amperage draw		525*	
	Volts		3.4*	
	Torque (ft.lbs.)		14*	
No load test	Amperage draw		125*	
	Bolts		5.4*	
	R.P.M.		2500*	
	Rotation (commutator end)		C.C.W.*	
Bearings	Commutator end		Cast iron*	
	Drive end		Graphite lubricated bushings*	
	Over running clutch		No*	
Pinion meshes	On front of flywheel*			
No. of teeth in flywheel gear	139			
Normal engine cranking speed	65 R.P.M.*			
No. of teeth in pinion gear	9*			
Gear ratio: Starter to flywheel	15.44 : 1			
Starting device	Starterator*	Direct foot-actuated control*		



# CHEVROLET 1937 SPECIFICATIONS

LIGHTS		PASSENGER		TRUCKS	
		MASTER DELUXE	MASTER	1/2 TON	1 1/2 TON
Head Lamps	Type	Two beam*			
	Diameter	7-15/16"		8-3/16"	
	Lens Type	Glass			
	Diameter	6-1/2"		7"	
	Bulb Type	Two filament			
	Number	2320-L	2320-L	2320-L	2320-L
	Candle power, each beam	32 Upper*	32 Upper*	32 Upper	32 Upper
		21 Lower*	21 Lower*	21 Lower	21 Lower
	Reflector-Type	Tiltrayo			
	Dimmed by	Depressed beam, foot-operated switch*			
Parking light bulb	Location	In headlamps*			
	Size	55*			
	Candle power	1-1/2*			
Tail and stop lamp	Type	Combinations			
	Tail light bulb size	65*			
	Stop light bulb size	65*	87*		
	Bulb candle power	3*	15*		
	Tail light in series with dash light	No*			
	Stop light operation	Hydraulic switch on brake main cylinder*			
Dash Light	Number used	2*			
	Size	55	51*		
	Candle power	1-1/2	1*		
Dome Light	Size	81 (except HALF TON CCS-87)			
	Candle power	6 (except HALF TON CCS-15)			
Fuse	Type	3A*			
	Volts	6*			
	Amperes	15*			
	Location	On back of ammeter*			
Lighting switch	Make	Delco-Remy*			
HORN	Make	Delco-Remy*			
	Type	Vibrator*			
	Tone adjustment	Screw type*			
	Location	Left side of cylinder head*			
RADIO	Location	Under running boards	None		
ANTENNA	Loud speaker location	On dash or above W.S.	None		
SPL.EQUIP.	On what body styles	All (SDL-dash only)	None		
TOOLS					
Jack	Type	Special long screw*	2000# cap*	3500# cap*	
	Raised height	Adjustable to requirements	14-1/8*	15-1/2*	
	Lowered height	Adjustable to requirements	8-1/8*	9-1/2*	
Hand tire pump	All*				
Screw driver	3-1/2" round shank*				
Adjustable auto wrench	9"				
Combination pliers	8"				
Ball peen hammer	10 oz.*				
Open end wrench	All*				
Spark plug wrench	All*				
Lubrication gun and oil can	All*				
Wheel wrench	All*				
Starting crank	All*				

# CHEVROLET 1937 SPECIFICATIONS

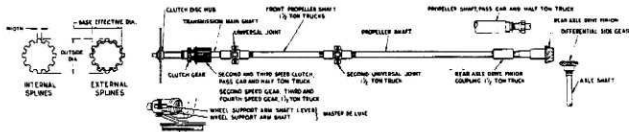

SPLINES	Passenger Cars and HALF TON Truck		1 1/2 TON Truck		
	INTERNAL	EXTERNAL	INTERNAL	EXTERNAL	
Clutch disc hub and transmission clutch gear shaft.	Number	10 <sup>0</sup>			
	Width	.174 - .176 <sup>0</sup>	.1715 - .1735 <sup>0</sup>	.174 - .176 <sup>0</sup>	.1705 - .1735 <sup>0</sup>
	Outside dia.	1.134 - 1.144 <sup>0</sup>	1.110 - 1.121 <sup>0</sup>	1.134 - 1.144 <sup>0</sup>	1.110 - 1.121 <sup>0</sup>
	Base eff. dia.	.920 - .925 <sup>0</sup>	.918 max. <sup>0</sup>	.920 - .925 <sup>0</sup>	.918 max. <sup>0</sup>
Transmission mainshaft sliding gears and gear clutch diameters.	Number	6 <sup>0</sup>			
	Width			.374 - .375 <sup>0</sup>	.3685 - .3705 <sup>0</sup>
	Shaft		1.715 - 1.725		1.4705 - 1.4805 <sup>0</sup>
	Second gear		1.715 - 1.725	1.4995 - 1.5035 <sup>0</sup>	
	Third & fourth		1.715 - 1.725	1.4995 - 1.5035 <sup>0</sup>	
	First & rev.	2.845 - 2.855			
	Gear clutch	1.745 - 1.755			
First U joint on trans. mainshaft (All) & 2nd U-jt. on front prop. shaft (1 1/2 TON)	Number	10			
	Width	.152 - .154	.151 - .152	.214 - .215 <sup>0</sup>	.2120 - .2135 <sup>0</sup>
	Outside dia.	.985 - .993	.960 - .970	1.380 - 1.388 <sup>0</sup>	1.355 - 1.365 <sup>0</sup>
	Base eff. dia.	.849 - .857	.844 max.	1.184 - 1.186 <sup>0</sup>	1.177 max. <sup>0</sup>
First U joint on front prop. shaft (All); also 2nd U jt. on rear prop. shaft (1 1/2 TON)	Number	10 <sup>0</sup>			
	Width	.160 - .162 <sup>0</sup>	.156 - .159 <sup>0</sup>	.1990 - .2016 <sup>0</sup>	.196 - .198 <sup>0</sup>
	Outside dia.	1.057 - 1.065 <sup>0</sup>	1.030 - 1.032 <sup>0</sup>	1.306 - 1.312 <sup>0</sup>	1.283 - 1.284 <sup>0</sup>
	Base eff. dia.	.907 - .915 <sup>0</sup>	.847 - .863 <sup>0</sup>	1.1145 - 1.1195 <sup>0</sup>	1.0515 - 1.0605 <sup>0</sup>
Coupling of rear end of propeller shaft and rear axle drive pinion shaft.	Number	10 <sup>0</sup>			
	Width	1.605 - 1.615 <sup>0</sup>	1.585 - 1.605 <sup>0</sup>	1.195 - 1.2005 <sup>0</sup>	.2010 - .2035 <sup>0</sup>
	Outside dia.	1.057 - 1.065 <sup>0</sup>	1.027 - 1.035 <sup>0</sup>	1.306 - 1.321 <sup>0</sup>	1.278 - 1.284 prop. shaft <sup>0</sup> 1.2800 - 1.2820 pinion <sup>0</sup>
	Base eff. dia.	.907 - .915 <sup>0</sup>	.847 - .863 <sup>0</sup>	1.1115 - 1.1195 <sup>0</sup>	1.0535 - 1.0625 <sup>0</sup>
Diff. side gears and axle shafts. (Pass. cars only)	Number	10			
	Width	.180 - .183	.178 - .180		
	Outside dia.	1.186 - 1.193	1.1525 - 1.1575		
	Base eff. dia.	1.039 - 1.044	1.004 - 1.014		
Diff. side gears and axle shafts. HALF and 1 1/2 TON trucks.	Number	10 <sup>0</sup>			
	Width	.189 - .192 <sup>0</sup>	.187 - .189 <sup>0</sup>	.259 - .262 <sup>0</sup>	.257 - .259 <sup>0</sup>
	Outside dia.	1.2555 - 1.2625 <sup>0</sup>	1.222 - 1.227 <sup>0</sup>	1.6735 - 1.6785 <sup>0</sup>	1.6345 - 1.6445 <sup>0</sup>
	Base eff. dia.	1.095 - 1.100 <sup>0</sup>	1.060 - 1.070 <sup>0</sup>	1.472 - 1.477 <sup>0</sup>	1.440 - 1.450 <sup>0</sup>
Wheel support arm shaft lever, Deluxe Master only.	Number	16 <sup>0</sup>			
	Width		.133 - .134 <sup>0</sup>		
	Outside dia.	1.3815 - 1.3865 <sup>0</sup>	1.3575 - 1.3625 <sup>0</sup>		
	Base eff. dia.	1.249 - 1.251 <sup>0</sup>	1.245 max. <sup>0</sup>		

REVISIONS:

## CHEVROLET 1937 SPECIFICATIONS

## ANTI-FRICTION BEARINGS

FUNCTION	MAKE	PART NO.	TYPE	INSIDE DIAMETER	OUTSIDE DIAMETER	WIDTH
Front Wheel						
Inner	H.D.	*909002 F	Cup and Cone	1.1999-1.1904	2.9625-2.9635	1.135 - 1.155
	H.D.	*909026 E	Cup and Cone	1.4060-1.4065	3.1491-3.1501	1.218 - 1.236
Outer	H.D.	*909001 F	Cup and Cone	.7498 - .7503	2.0795-2.0805	.698 - .719
	H.D.	*909025 E	Cup and Cone	.8438 - .8440	2.2495-2.2505	.780 - .800
Arm shaft	Chev.	*373467 B	Short Roller	48 rollers	.0938	.935 - .975
	Chev.	*377369 B	Long Roller	42 rollers	.0938	1.157 - 1.187
Lever pin	Chev.	*373464 B	Short Roller	32 rollers	.0938	.955 - .975
King Pin Thrust	H.D.	*382669 CD	Ball Thrust	.735 - .760	1-9/16	9/16
	H.D.	*373476 B	Ball Thrust	.968 - .893	1-5/8	9/16
	H.D.	*365309 E	Ball Thrust	.9225 - .9475	1-23/32	5/8
Steering Worm	Chev.	261866 A	Taper Roller		1.790 - 1.7906	
Roller Tooth	Chev.	*262805 E	Ball	.4370 - .4375		1.030 - 1.034
Generator	H.D.	*901203 A	Ball	.6689 - .6693	1.5743-1.5748	.4724
Clutch-Pilot	H.D.	*907109 A	Ball	.8901 - .8906	1.3774-1.3780	.349 - .354
Transmission						
Clutch gear	H.D.	954141 F	Ball	1.3775-1.3780	2.8340-2.8346	.6643 - .6693
Main shaft						
Front	H.	*141854 E	Roller	12 rollers	.1870 - .1875	
	H.	590782 F	Roller	14 rollers	.1875 - .1875	.512 - .527
Rear	H.D.	954168 F	Ball	.9839 - .9843	2.4403-2.4409	.6543 - .6593
	H.D.	*903307 E	Ball	1.3775-1.3780	3.1490-3.1495	.8218 - .8265
Cntr. shaft						
Front	H.	*142260 E	Roller	1.4980-1.4994	2.4409-2.4415	.6249 - .6299
Rear	E.	*121856 E	Roller	1.7318-1.7323	2.8346-2.8352	.6543 - .6593
Prop. shaft	H.D.	*903807 E	Ball	1.3775-1.3780	2.8340-2.8346	.6543 - .6593
Rear Axle						
Pinion-Fr.	H.D.	905306 BC	Dbl. row ball	1.1807-1.1811	2.8340-2.8346	1.1825-1.1875
	H.D.	*905206 D	Dbl. row ball	1.1807-1.1811	2.4403-2.4409	.9345 - .9375
	H.D.	*905309 E	Dbl. row ball	1.7712-1.7717	3.9362-3.9370	1.5595-1.5625
Pinion-Rr.	H.	*125630 F	Roller	1.8297-1.8291	3.1206-3.1250	.743 - .748
	H.D.	*901305 E	Ball	.9839 - .9843	2.4403-2.4409	.6543 - .6593
Side Bearings	H.	127981 BC	Barrel roller	1.6924-1.6929	2.9523-2.9528	.659 - .679
	H.D.	*802100 D	Ball	1.6924-1.6929	3.1490-3.1496	.7097 - .7117
	H.D.	954166 E	Ball	2.4403-2.4409	3.9362-3.9370	.8218 - .8268
Axle shaft	H.	111103 BC	Roller	1.2951-1.2957	2.4056-2.4062	1.209 - 1.219
	H.	*111104 D	Roller	1.5302-1.5308	2.7912-2.7918	1.334 - 1.344
Rear Wheel						
Inner	H.	144527 E	Barrel roller	2.8250-2.8255	4.4680-4.4688	.970 - .975
Outer	H.	144526 E	Barrel roller	2.2500-2.2505	3.8750-3.8758	.895 - .900

NOTE: Letter following bearing number indicates units using this bearing.

SYMBOLS: A - All; B - Master Deluxe; C - Master; D - Commercial;  
E - Truck; F - Pass. & Comm.; H - Hyatt; H.D.-New Departure.

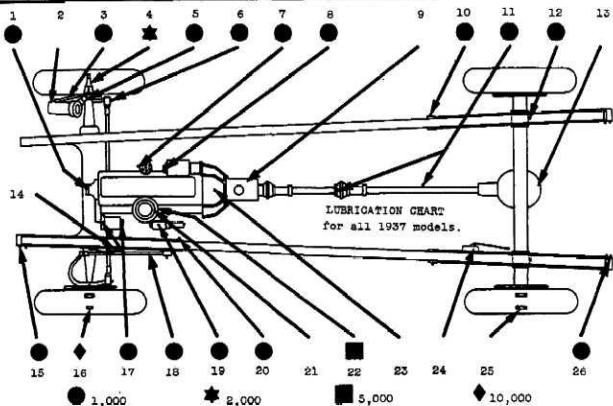

LUBRICATION CHART  
for all 1937 models.

- 1 - Water pump - fill oil cup with good grade engine oil.
- 2 - Front spring unit (DMAS)-keep filled with genuine shock insulation fluid.
- 3 - Front spring unit radius rod (DMAS)-chassis lubricant.
- 4 - Front spring unit spindle bushing (DMAS) remove plug and fill with petroleum jelly.
- 5 - King pin (two fittings) use chassis lubricant.
- 6 - Tie rod (fitting at each end)-use chassis lubricant.
- 7 - Distributor-fill and turn down grease cup-use soft, smooth cup grease.
- 8 - Starting motor - two or three drops of light oil.
- 9 - Transmission - Capacity: Passenger cars 1-3/4 pints, HALF TON 3-speed 1-1/2 pints; truck 4-speed transmission-6-1/2 pints. Keep filled to level of filler boss opening. SAE 160 in summer; SAE 90 in winter; SAE 90 plus 10% kerosene in temperatures below zero.

- 10 - Spring bolts-each side of HALF TON and 1 1/2 TON-use chassis lubricant.
- 11 - Universal Joint & Propeller shaft bushing. 1-1/2 TON trucks only-use chassis lubricant.
- 12 - Spring seat-one at each rear spring-chassis lubricant.
- 13 - Rear axle differential. Passenger cars only 3-1/2 pints of special hypoid gear lubricant. HALF TON - 4-1/2 pints; 1-1/2 TON-7 pints. Use SAE 160 in summer; SAE 90 in winter; SAE 90 plus 10% kerosene in temperatures below zero.
- 14 - Front shock absorbers-Master and HALF TON keep filled with genuine Chevrolet shock absorber fluid.
- 15 - Front spring shackles-use chassis lubricant.
- 16 - Front wheel bearings-repack with high melting point wheel bearing grease.
- 17 - Generator-two or three drops of light oil.

- 18 - Steering connecting rod-use chassis lubricant - one fitting at each end.
- 19 - Steering gear-use steering gear lubricant.
- 20 - Spring bolt-use chassis lubricant.
- 21 - Air cleaner-remove and clean out with gasoline. Dip screen in engine oil; keep felt pad dry.
- 22 - Accelerating pump shaft-remove dust cover, fill screw hole with graphite grease.
- 23 - Clutch release bearing-fill reservoir with SAE 160 in summer, SAE 90 in winter when squeak occurs.
- 24 - Rear shock absorbers-Master and HALF TON-keep filled with genuine Chevrolet shock absorber fluid.
- 25 - Wheel bearings on 1-1/2 TON truck only-two on each side-receive lubricant from rear axle differential.
- 26 - Rear spring shackles-use chassis lubricant.