

BUILT, AS ARE ALL
COTNER / BEVINGTON
PROFESSIONAL CARS,
ON OLDSMOBILE
NINETY EIGHT CHASSIS.

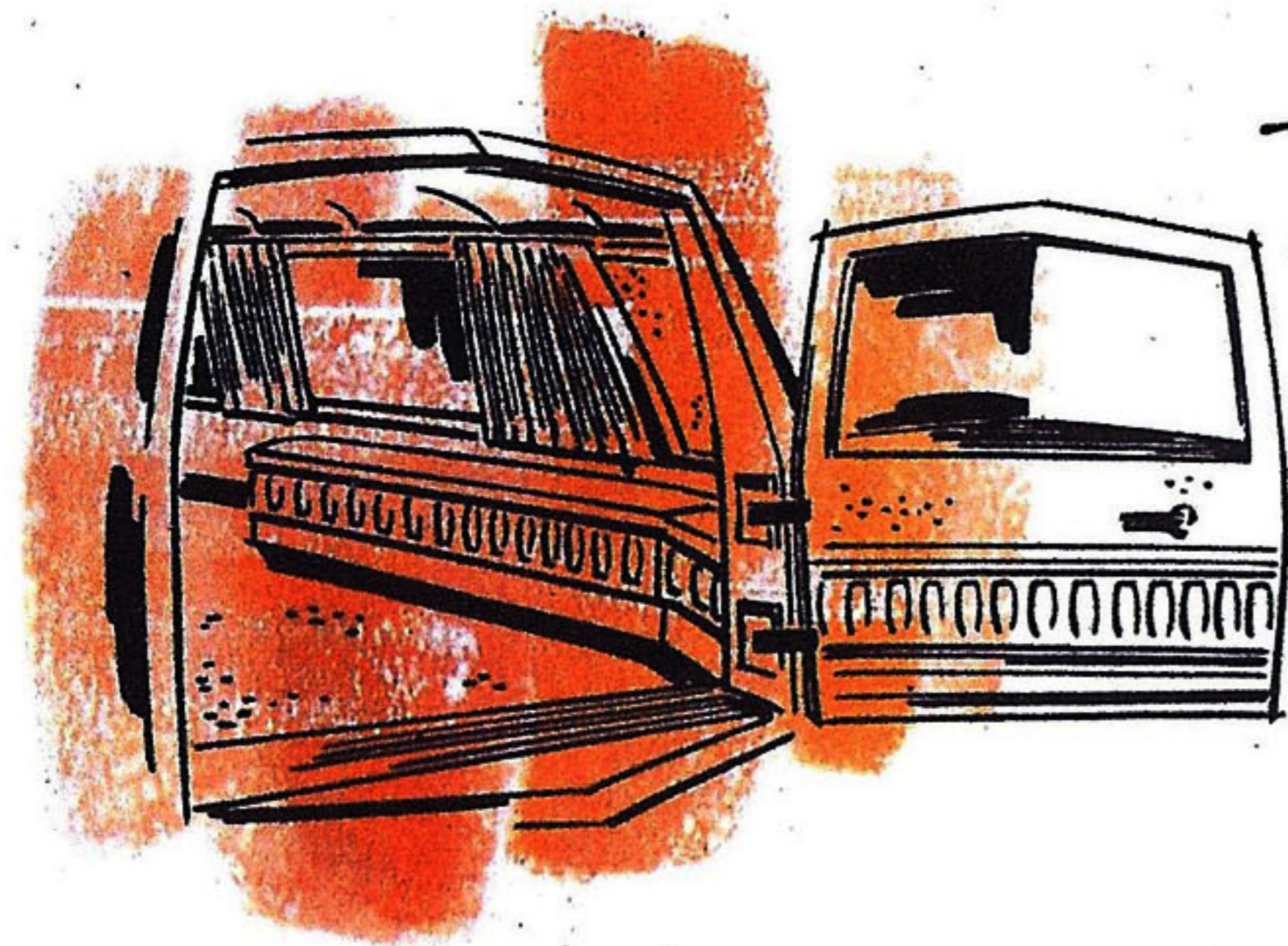



The Seville/41" **HEADROOM AMBULANCE** for 1966

Engineering excellence . . . minimal maintenance . . . economic efficiency . . . all this is built into a vehicle with "big car" styling and convenience.

Illustrated, left: The largest rear door in its field—45" wide x 37" high—is just one of the many features that puts this ambulance ahead of its competition.

Cotner/Bevington

OLDSMOBILE NINETY EIGHT LINE FOR 1966

Ambulances



C/B

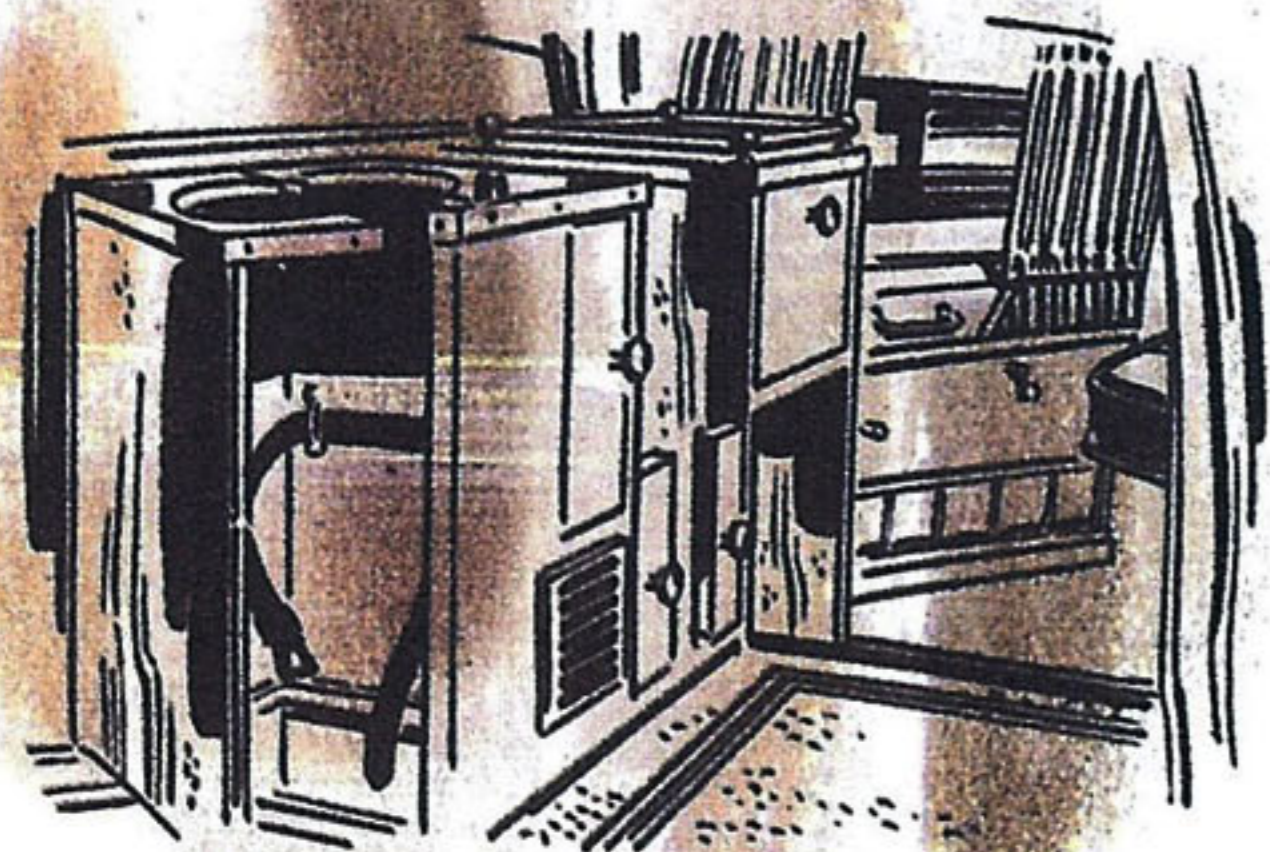

The Cotington/42"

HEADROOM AMBULANCE for 1966

BUILT ON OLDSMOBILE NINETY EIGHT CHASSIS

(Exterior illustrated on the cover)

The most popular ambulance in the line. Handsome and efficient, with all the features you'll find in more expensive vehicles. Adaptable for meeting rescue requirements.

Illustrated above: Cabinets—custom-built to your specifications—are optional features exemplifying our ability and desire to meet your needs.

Specifications On All Three Ambulances

(NOTE: All Cotington-48 and -42 specifications are the same except where noted)

GENERAL: Wheelbase; Cotingtons 150", Seville 126". Overall Length; Cotingtons 247", Seville 223". Overall Height; Cotington-48 73", Cotington-42 67", Seville-41 66". Overall Width; All models 79". Tire Size; All models 8.85 x 14, 8-Ply Rating, Black. Weight; Cotington-48 5400 lbs.; Cotington-42 5340 lbs., Seville-41 5040 lbs. Rear Door Openings; Cotington-48 43" x 41", Cotington-42 and Seville-41 43" x 37". Fuel Tank Capacity; All models—25 gallons.

ENGINE: Super Rocket High-Compression, 90° V-Type; 365 Horsepower @4800 rpm. Bore and Stroke, 4.125 x 3.975; Piston Displacement, 425 cu. in.; Compression ratio, 10.25 to 1; 4-Barrel Quadrajet Carburetor; Torque, 470 @ 3200 rpm.

CHASSIS: Guard-Beam frame, perimeter design. *Front suspension:* Coil springs with center-mounted direct-acting shock absorbers (1" dia.). Ball-joint suspension and stabilizer bar. *Rear suspension:* Four-link design with axle-mounted coil springs. Angle-mounted direct-acting shock absorbers.

TRANSMISSION: Heavy Duty Turbo Hydra-Matic Drive' standard. Three-speed torque converter with variable pitch stator.

STEERING: Roto-Matic Power Steering.

BRAKES: Pedal-Ease Power Brakes. Cast-Iron Drums with Air-Scoop Cooling Flanges. Self-Adjusting. Wider Brake Drums: 11" x 2.75" front; 11" x 2.5" rear. 229.2 sq. in. Total Lining Area.



BUILT, AS ARE ALL
COTNER / BEVINGTON
PROFESSIONAL CARS,
ON OLDSMOBILE
NINETY EIGHT CHASSIS.



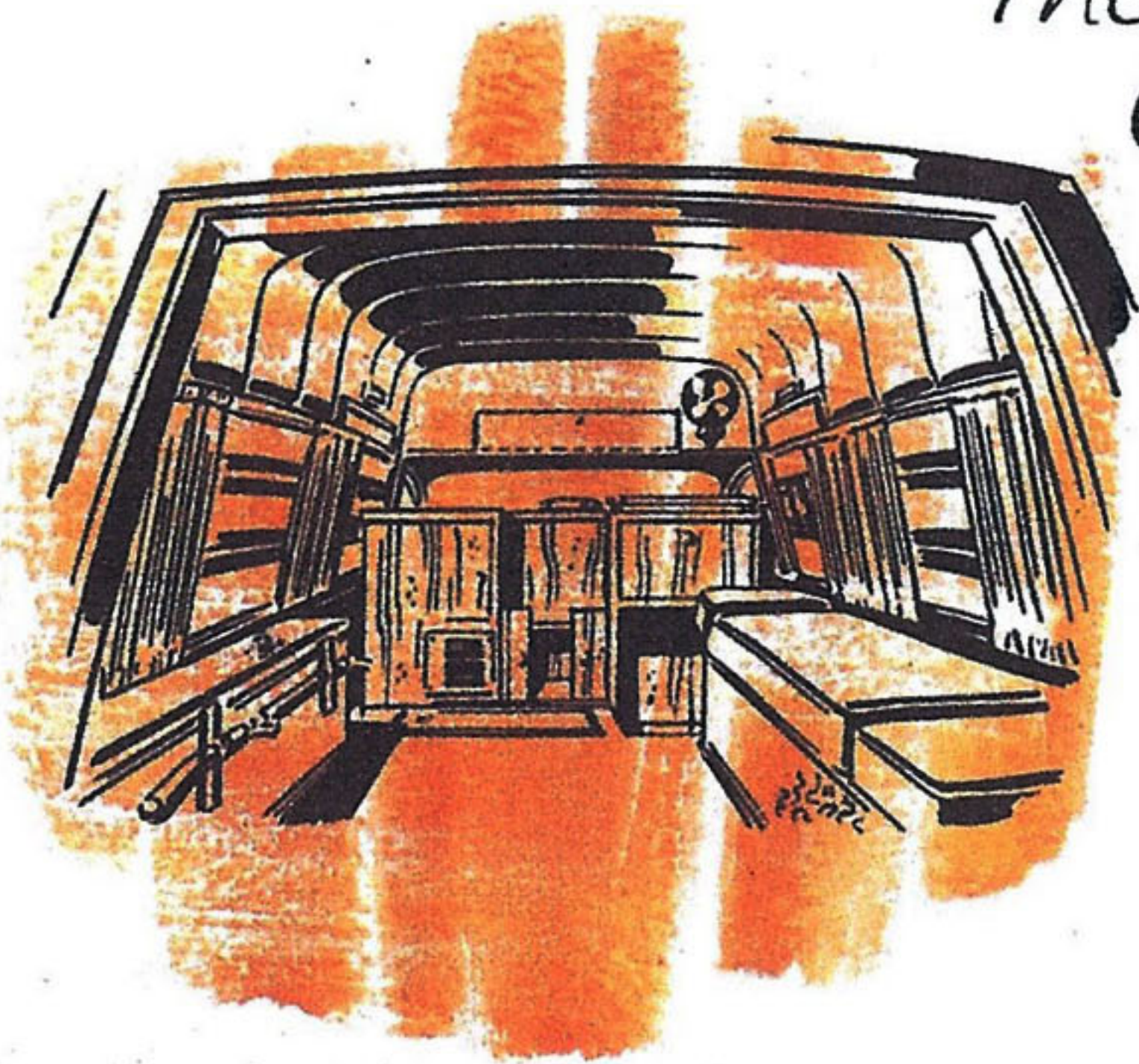

The Cottingham 48"

HEADROOM AMBULANCE for 1966

The commanding appearance of this ambulance assumes authority in any situation. An additional six inches of headroom not only add spaciousness, but provide extra safety, make care for patients easier.

Illustrated, left: Squad Bench (optional) can be used as a bed for a second patient, or sitting space for three persons.

Exclusive features!

PERFORMANCE-DESIGNED ON ALL THREE COTNER/BEVINGTON AMBULANCES

These Features are Standard on All Three Vehicles

FRONT COMPARTMENT

1. Heater and defrosters
2. Windshield washers
3. Professional car instrument panel equipment; wipers, visors, clock, turn signals, ash trays, rear-view mirror, etc.
4. Front doors—key locked (2)
5. Trim—Tu-tone optional using our recommended standard trim materials and colors
6. Oldsmobile carpet—front floor
7. Clear glass windshield
8. Manually adjustable driver's seat with divided back
9. Zipper 12" in front headlining

REAR COMPARTMENT

1. Rear doors—key locked (2)
2. Wheel Jack—Oldsmobile
3. Drapes—airline style in all rear window openings
4. One pair nameplates—Vise grip style (extra charge for over 18 letters and spaces)
5. Cot fastener—Removable and adjustable—L.H. side
6. Heavy duty front and rear springs and shocks
7. Built-in hold-open door checks—three rear door
8. Trim—Tu-tone optional using our recommended standard trim materials and colors
9. Underbody and fenders—completely under-coated

WE RESERVE THE RIGHT TO CHANGE SPECIFICATIONS AS NECESSARY WITHOUT OBLIGATION

Additional Standard Features on the Cotington-48 and -42 Ambulances

1. Dome-light—door and manually controlled
2. Curved C.V. and door glass
3. Front doors equipped with hold-open door checks
4. Accessory switch panel above instrument panel
5. Heater—Cotner/Bevington standard—under front attendant seat R.H.
6. Attendant seats (2)—fold into floor
7. Dome lights (3)—switch on wheelhouse
8. Cot lamp—automatic with rear door
9. Stepwell lamp—automatic with R.H. door and switch on wheelhouse
10. Linen compartment—overhead of partition
11. Sliding partition glass
12. Ambulance decals on side doors and rear quarter windows
13. Assist handles (2)—rear door and R.H. side door
14. Linoleum floor
15. Medicine Cabinet #7090, Formica-covered, without air; #7089, Formica-covered, with air.

Additional Standard Features on the Seville-41 Ambulance

1. Curved front C.V. and door glass
2. One attendant seat—R.H. side
3. Grab handle—inside rear door
4. Dome light—rear door controlled
5. Ambulance decals in rear quarter window openings
6. Linen compartment—in front of rear compartment floor R.H.

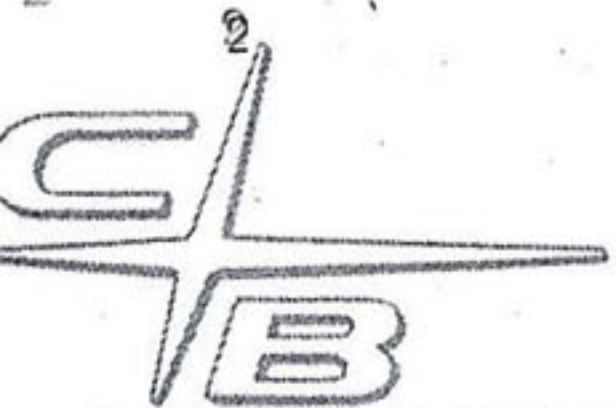

*Interior Dimensions
on the 1966 Cotington-48"
Ambulance*

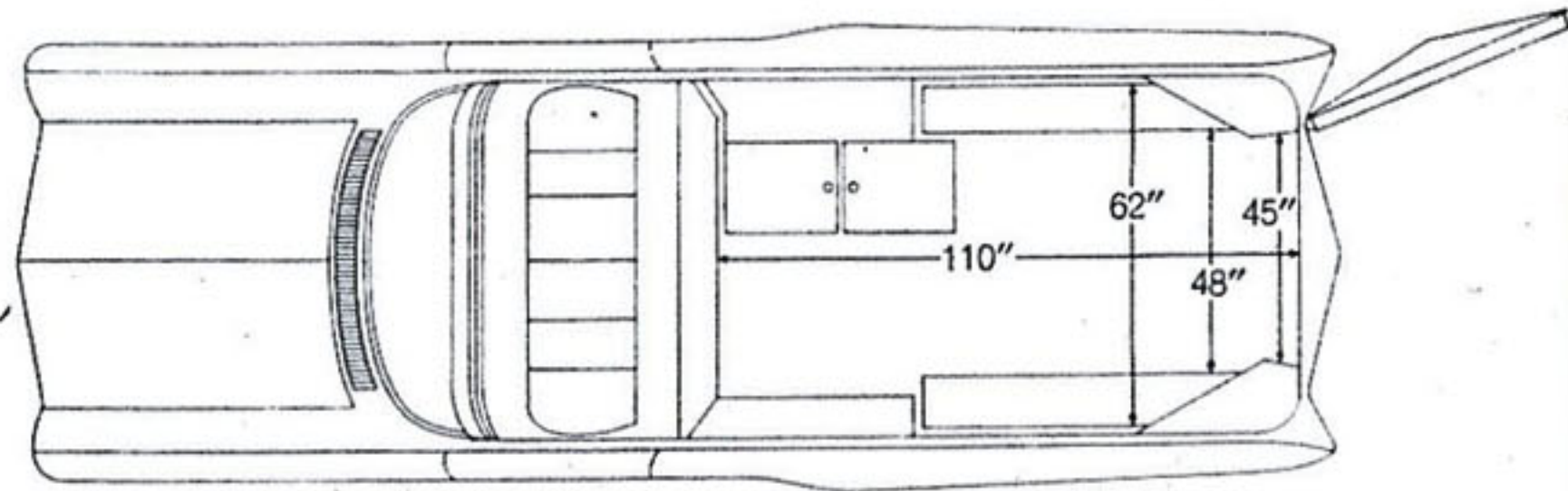
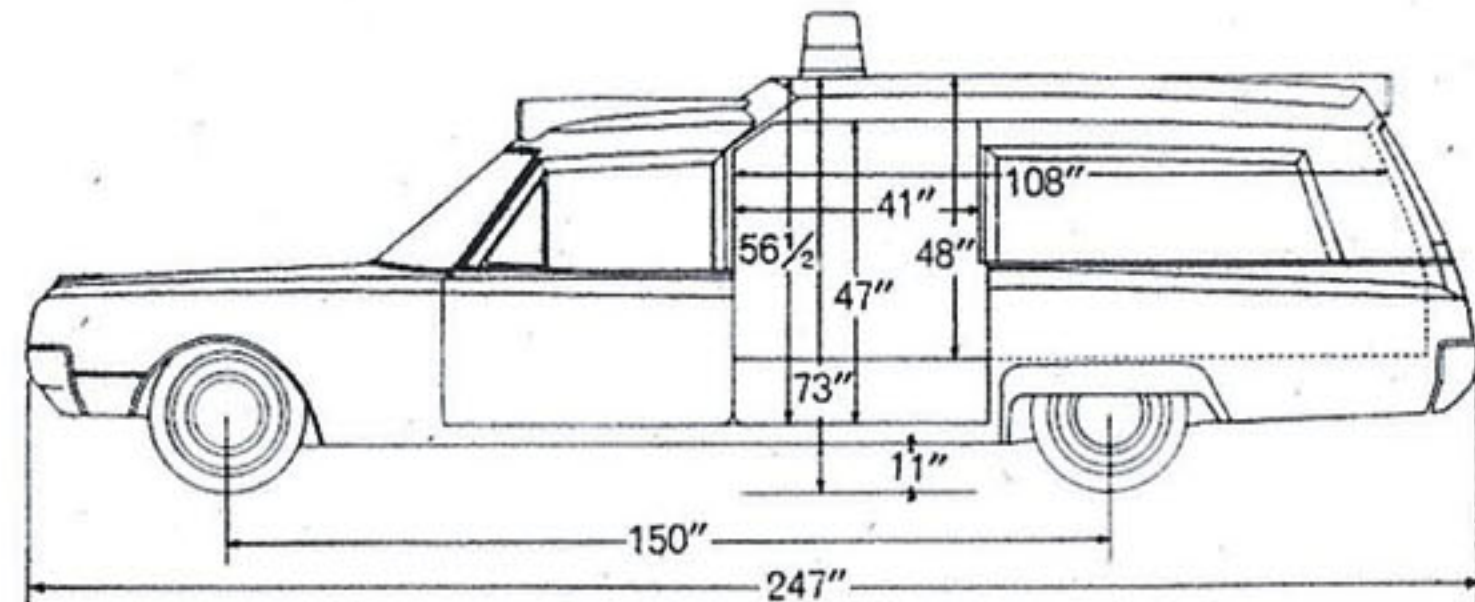
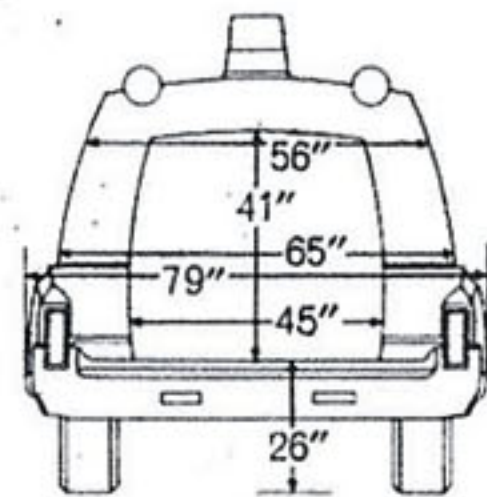

*Interior Dimensions
on the 1966 Cotington-42"
Ambulance*

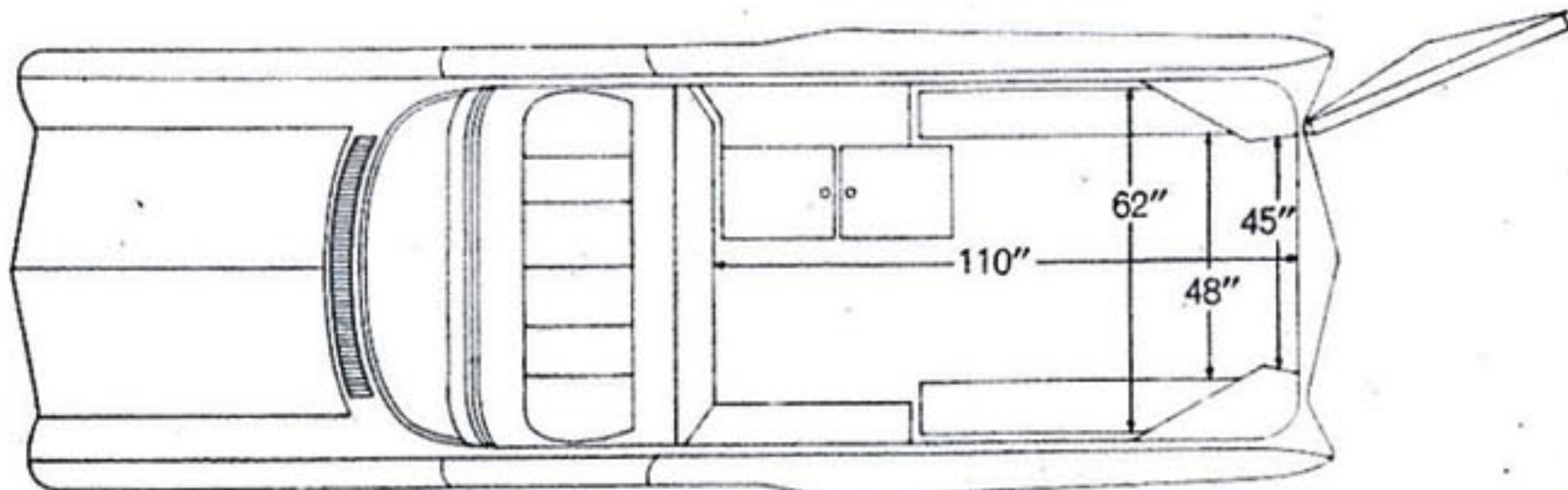
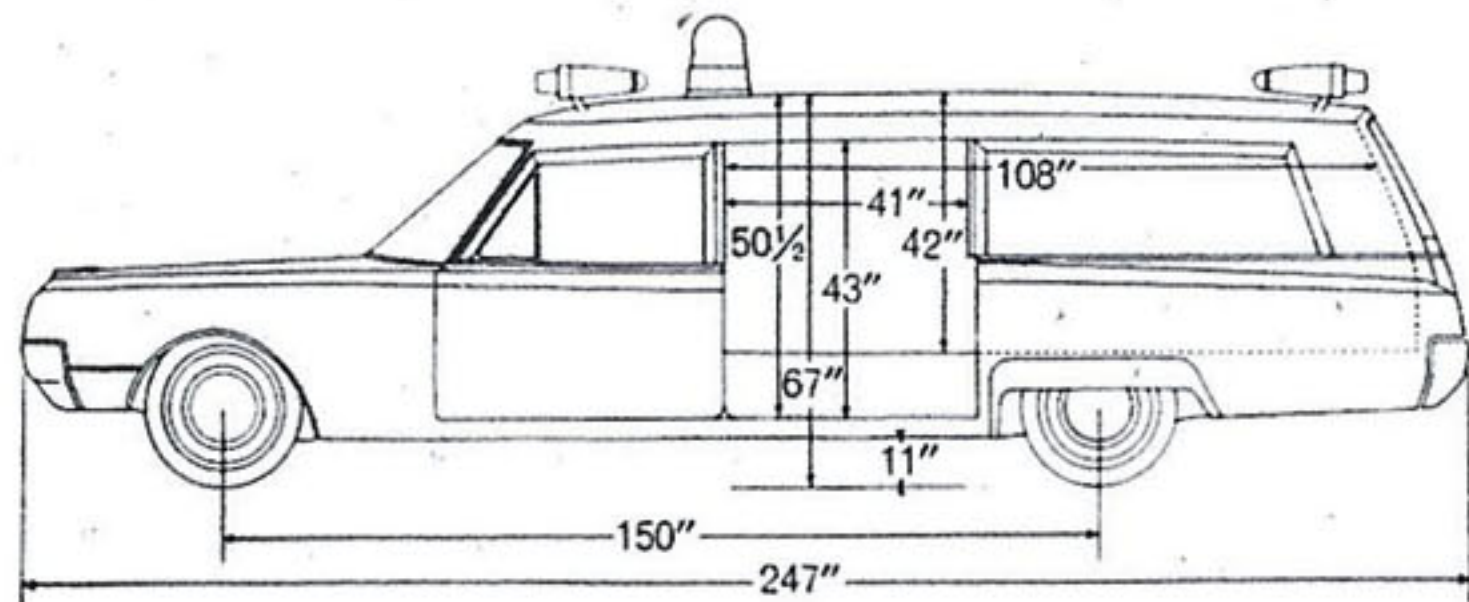
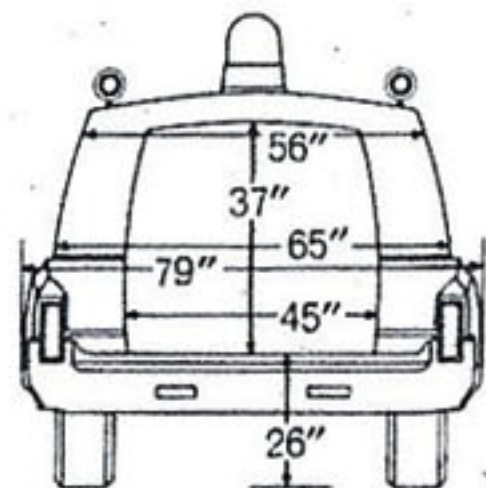

*Interior Dimensions
on the 1966 Seville-41"
Ambulance*

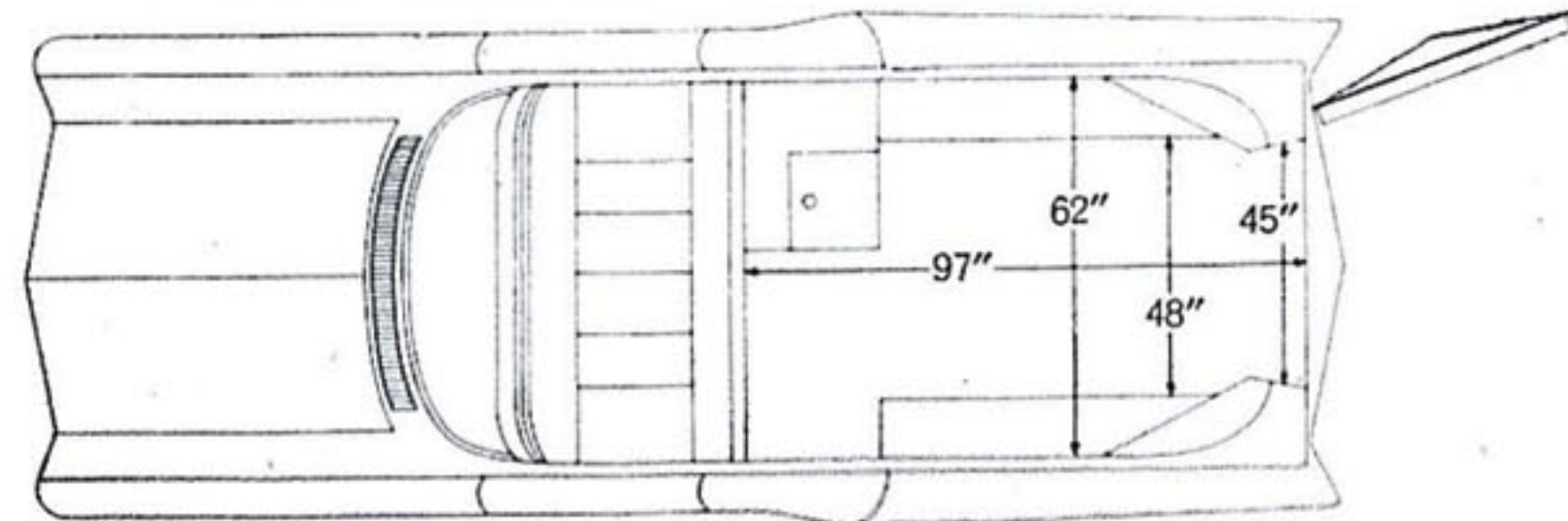
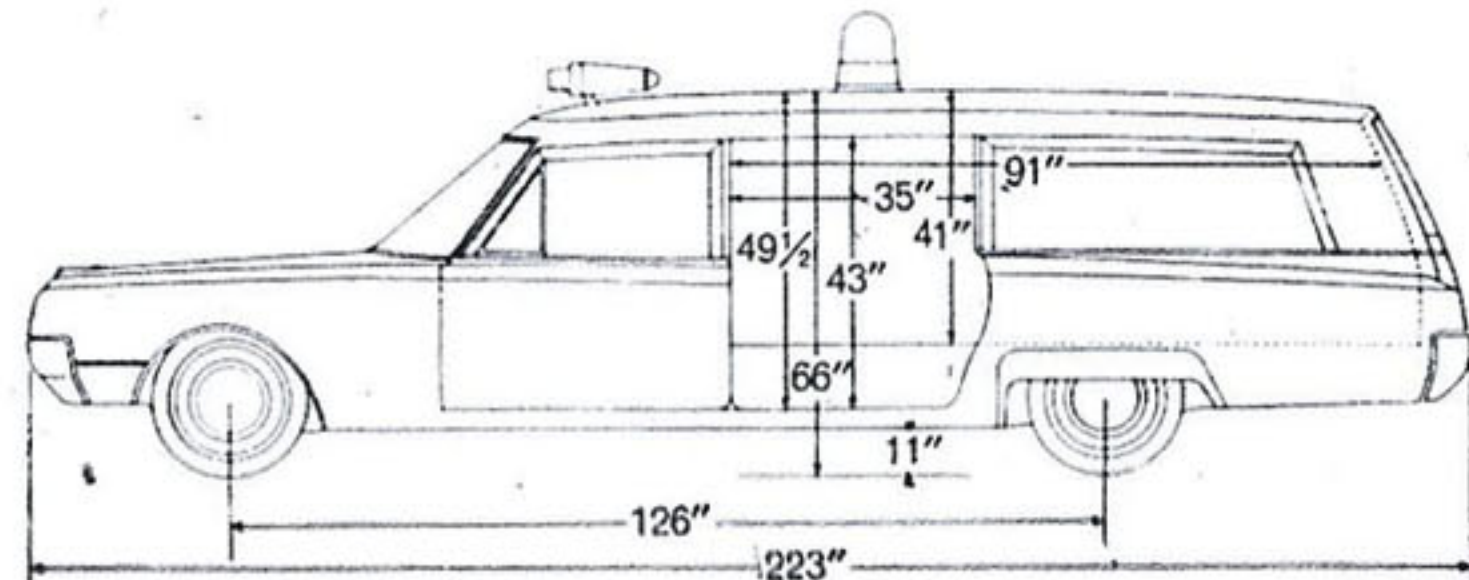
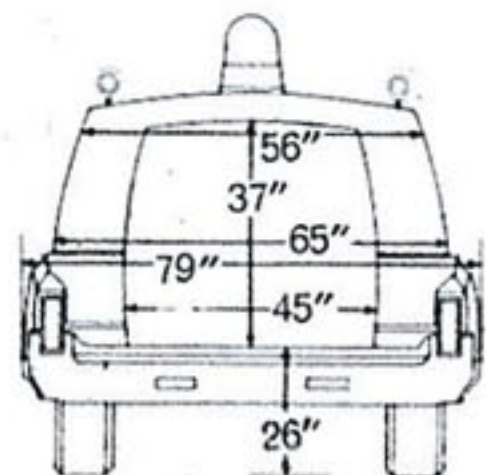

Cotner/Bevington Ambulances are Distributed By: