



McLaughlin Motor Car Co. Limited

331-341 7th AVENUE WEST

:::

CALGARY, ALBERTA

McLAUGHLIN-BUICK SIX

Valve-in-Head

MOTOR CARS



Master and Special Models

OSHAWA, ONTARIO, CANADA

McLAUGHLIN MOTOR CAR COMPANY, LIMITED

Subsidiary of General Motors of Canada, Limited

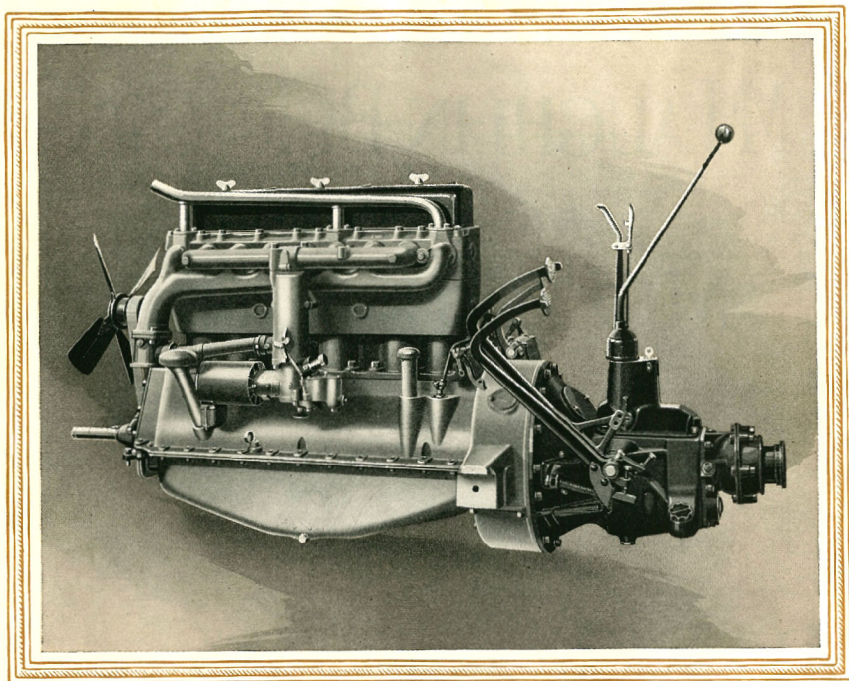

Power—and where it comes from

The thing that makes or mars a motor car is power. Power is the source of greatest satisfaction in a motor car.

McLaughlin-Buick power, supplied by the matchless McLaughlin-Buick Valve-in-Head engine, will carry the McLaughlin-Buick owner wherever he wants to go, slowly or quickly, quietly, steadily, irresistibly. In all things other than power the McLaughlin-Buick is equal to the best. In power it stands alone.

Every passing day adds proof that the McLaughlin-Buick Valve-in-Head principle is correct. It is a principle that is backed by scientific knowledge, and by more than twenty years of successful manufacturing experience.



THE BETTER McLAUGHLIN-BUICK

IN keeping with its slogan, "When better automobiles are built, McLaughlin-Buick will build them," McLaughlin-Buick again builds a better McLaughlin-Buick. This it offers to the motoring public in its line of sixteen models.

In doing so McLaughlin-Buick clinches still more firmly its position as a leader in the industry. It strengthens its hold on leadership by the same method that won it—for McLaughlin-Buick leadership was not attained by chance. McLaughlin-Buick leadership was earned.

Leadership came to McLaughlin-Buick because McLaughlin-Buick held firmly to one policy. That policy, which has spelled success for 17 years, is: To build into its product all those features which careful test has proved will add to the comfort, convenience, and economical operation of the McLaughlin-Buick.

This book will tell you how faithfully that policy has been carried out in the present McLaughlin-Buick models.

Increased power—increased strength

Power in both the Master Six and Special Six engines has been increased materially, without changing the fundamental principles of McLaughlin-Buick construction.

In order to preserve the extra margin of safety that McLaughlin-Buick always builds into its product, such units as the clutch, transmission, axles, frames, wheels, and all

other parts subject to the additional strains of increased power have been strengthened. The tires, too, have been increased slightly in size.

Sealed chassis—triple-sealed engine

Those features that have made the McLaughlin-Buick famous have been maintained—such as the McLaughlin-Buick Valve-in-Head engine; cantilever rear springs; the McLaughlin-Buick torque tube drive; the McLaughlin-Buick multiple disc clutch; and McLaughlin-Buick mechanically operated four-wheel brakes. The famous sealed chassis has been still further improved by placing three additional seals on the engine.

The air passing into the carburetor; the oil with which the engine is automatically lubricated; and the gasoline are now thoroughly cleansed, so that sediment and dirt have no chance to get into the working parts of the engine.

Durable Duco colors

The appearance of the cars has been made still more beautiful. The bodies are finished in durable Duco. Colors are most pleasing, with contrasting moldings and striping that add still further to the striking and distinctive appearance of the cars.

New radiator lines

The radiator design has not been changed, but has been made more beautiful by means of

more gracefully rounded corners, and a slight crown on the front. These changes are especially in keeping with the lines of the bodies on both the open and the closed models.

The interior finish of all models is fully in keeping with their fine exterior appearance. The tops on the open models are new and smart in appearance. The top on the special six touring is the permanent type, fitted with curtains, and especially built to accommodate winter enclosures.

The seats in all models have been newly designed and especially built to give more comfort, with particular reference to the driver.

Low insurance rates

Retaining the heavily insulated wiring in conduits and approved attaching clips, as approved by the fire insurance underwriters, results in McLaughlin-Buick cars enjoying the lowest insurance rating obtainable.

There are in addition to this feature many other improvements and conveniences that will be readily appreciated by the seasoned motorist, as well as the beginner.

These can only be fully appreciated after you have ridden in one of the new McLaughlin-Buicks.

The most striking feature—price

The most striking feature in connection with the present McLaughlin-Buick models is the prices at which they are offered.

While it has been generally accepted that McLaughlin-Buick during past years has offered a dollars and cents value far beyond that of any car on the market, the prices of these models make these cars unquestionably the greatest value that the world has ever known.

In spite of the increase in power and speed, and all the other features that will be found illustrated and described in this book, prices are still lower.

This is an accomplishment that would not be possible were it not for McLaughlin-Buick's years of experience in building motor cars; McLaughlin-Buick's complete manufacturing plant; most modern facilities; and enormous production.

McLaughlin-Buick states, without fear of contradiction, that it would be impossible for anyone to build the same value into a motor car that is built into the McLaughlin-Buick for the same price, if only a few thousand cars were built each year, rather than the hundreds of thousands that McLaughlin-Buick has successfully built in the past. For there are no miracles being performed today.

Helping you to judge values

To impress the buying public with the value that is built into the McLaughlin-Buick product, the McLaughlin Motor Car Company, Limited, in this book, not only illustrates and describes, the principles of McLaughlin-Buick construction, but also compares the various units, as constructed by McLaughlin-Buick, with cheaper types of construction.

The object is to demonstrate clearly that McLaughlin-Buick could, if it so desired, build automobiles to sell at a much lower price. But it will be readily seen that if McLaughlin-Buick did use these cheaper types of construction that the McLaughlin-Buick car would not render anywhere near the same satisfactory service that has made McLaughlin-Buick not only famous but a leader in the industry.

Because this plan of comparison has been followed, you will find this book of unusual value to you. It is a handy and reliable guide in judging automobile values—and it is only by judging values carefully and intelligently that you can be sure of getting the fullest possible return for your investment in transportation.

THE McLAUGHLIN-BUICK VALVE-IN-HEAD ENGINE

DYNAMOMETER tests and actual road performance have proved conclusively that the new McLaughlin-Buick engines, both Special and Master Six, are far in advance of average present day performance. Their horsepower has been materially increased, the Special Six engine developing 60 horsepower, and the Master Six 75 horsepower.

There has been no increase in compression and but eight per cent increase in displacement, due to a slight increase in the bore. But the horsepower has been raised sixteen per cent.

Improved carburetion and manifolding

The engine torque, which affects acceleration and hill climbing ability, has been raised to 140 foot-pounds on the Special Six, and to 178 foot-pounds on the Master Six.

Improved carburetion and manifolding has contributed to the increase in power and torque, meaning more speed and quicker getaway.

The maximum speed of the Special Sixes is 70 miles an hour and they travel from eighteen to more than twenty miles on a gallon of gasoline.

The maximum speed of the Master Sixes is 75 miles an hour and they travel from fifteen to eighteen miles on a gallon of gasoline.

In every test for horsepower, torque, and acceleration—tests conducted at the General Motors proving grounds—these McLaughlin-Buick models far surpassed in performance any other cars, placing themselves in a class of their own for power, efficiency and economy.

Thousands of added miles of life

Thousands of miles of life have been added to these new engines by means of an air cleaner, oil filter, and gasoline strainer. Illustrations on the following pages clearly demonstrate the efficiency and value of these features.

Three-point suspension

The McLaughlin engine is supported at two points in the rear and one in front, making what is known as a three-point suspension. No dis-

ortion of the frame, due to uneven road conditions, is thrown into the engine. The engine is not called upon to act as a cross-member. This adds to its life and reduces upkeep and service costs.

THE McLAUGHLIN-BUICK AIR CLEANER

MANY thousands of gallons of air are consumed for every gallon of gasoline used by automobile engines.

Road dust pollutes this air and very severely wears the engine's moving parts, because it is composed largely of minute particles of sharp-edged sand or quartz.

This dust forms an abrasive compound, because when it is sucked in with the carburetor air it mixes with the oil film on the cylinder walls, where

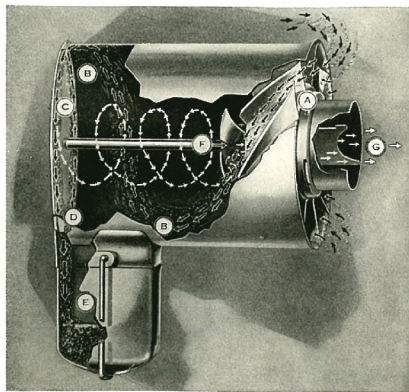

Diagram showing how the McLaughlin-Buick air cleaner presents dust from entering the carburetor.

A—Suction stroke of engine draws dust laden air through cleaner's directing vanes, which give it a rapid, spirally rotating motion.

B—Centrifugal force separates the dust particles from the air, throwing them against the inside wall of the cleaner.

C—The spiral movement of the dust along the inside surface of the cleaner wall brings it to rear circular end.

D—Dust is forced through small outlet

E—Dust collects in removable container

F—Clean air, indicated by white arrows, rotating spirally in centre portion, strikes directing plate (F) and screws itself out of cleaner.

G—Straightened current of clean air leaves cleaner to enter carburetor.

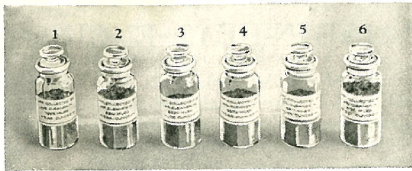

The efficiency of the McLaughlin Buick air cleaner is strikingly indicated by these bottles, which contain dirt collected from McLaughlin-Buick test cars by the air cleaner. The bottle on the left shows the amount of dirt collected in 7,593 miles driving—2.15 ounces. Bottle No. 2—6,941 miles—2.64 ounces. Bottle No. 3—6,290 miles—1.68 ounces. Bottle No. 4—3,505 miles—2.29 ounces. Bottle No. 5—4,317 miles—1.35 ounces. Bottle No. 6—8,136 miles—3.01 ounces.

it grinds away the engine's efficiency with each piston stroke.

Some means to prevent this dirt from entering the carburetor has been sought for many years, and now the General Motors laboratories have produced for McLaughlin-Buick a device, without moving parts, that accomplishes the work.

Its principle of operation is similar to that of the ordinary cream separator. Centrifugal force is used to separate two substances of different specific gravities—in this case, air and dust.

THE GASOLINE STRAINER

IN a further effort to eliminate the possibility of dirt getting into the engine, impairing its efficiency and shortening its life, McLaughlin-Buick has adopted a gasoline filter or strainer. This collects all sediment or dirt that might be in the gasoline and prevents it from reaching the carburetor. It practically eliminates the possibility of dirt getting into the needle valve of the carburetor and interfering with its efficient operation.

This feature, too, has been developed as the result of numerous test and experiments.

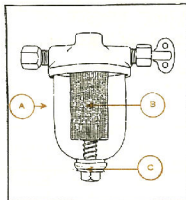

The operation of the gasoline filter or strainer is shown in this diagram. Point (A) indicates the glass container from which the gasoline passes through the screen (B), leaving all sediment in the glass. The glass may be easily removed and cleaned by unscrewing the nut (C). After a few thousand miles driving, the efficiency of this filter will be clearly demonstrated by the amount of dirt found in the glass.

THE OIL FILTER

BECAUSE it has been found that considerable sediment and dirt find their way into the bearings of an automobile engine through the oil, a method of filtering has become necessary.

Extensive experiments were conducted with various appliances and every known method of filtering oil was given a thorough test in the McLaughlin-Buick laboratories and in road service. The result was that McLaughlin-Buick adopted the type illustrated here because of its greater efficiency.

The value of the oil filter is clearly demonstrated by the illustration showing the condition of oil at various mileages on McLaughlin-Buick test cars.

It is a well known fact that practically every invention or improvement developed for use in connection with automobiles is submitted to McLaughlin-Buick or the General Motors Corporation first, because of their size and importance in the industry. Consequently McLaughlin-Buick always has the opportunity of being the first to adopt these appliances, even when they are developed by engineers outside the organization. But before any feature is adopted by McLaughlin-Buick it must prove itself to be practical and efficient by extensive tests, as this oil filter has done.

COMPLETE AUTOMATIC LUBRICATION

THE lubrication system of the McLaughlin-Buick engine is the full pressure type, which means that oil is pumped under pressure to all main bearings,

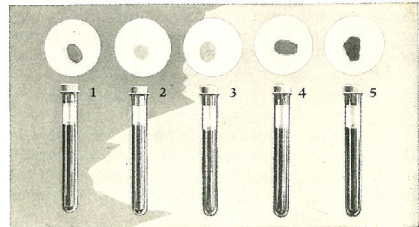

The efficiency of the oil filter is strikingly indicated by these samples of oil taken from McLaughlin Buick test cars.

Bottle No. 1—1,000 miles without filter. Abrasive sediment .10%
 Bottle No. 2—1,000 miles with filter. Abrasive sediment .00%
 Bottle No. 3—10,000 miles with filter. Abrasive sediment .04%
 Bottle No. 4—15,000 miles with filter. Abrasive sediment .10%
 Bottle No. 5—25,000 miles with filter. Abrasive sediment .11%

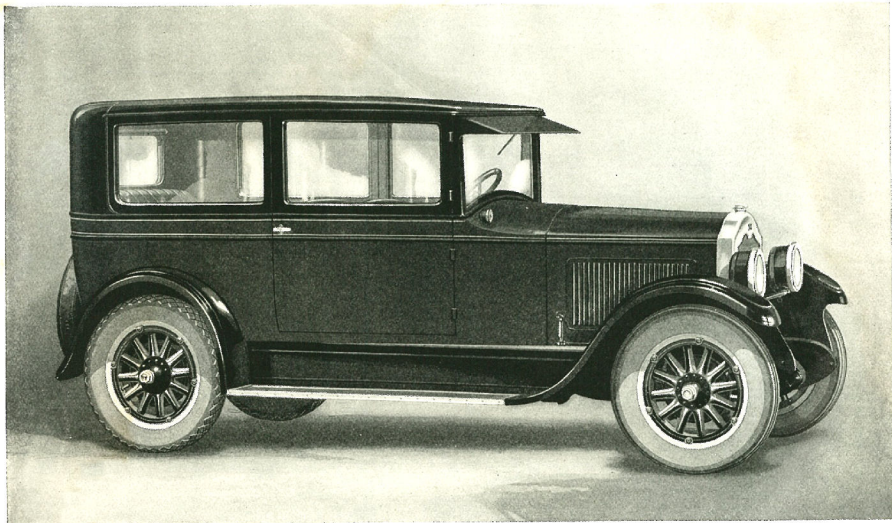

McLaughlin-Buick five-passenger two-door Sedan
Special Six . Model 20

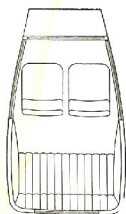

This roomy two-door Sedan sets a new standard for cars with two doors. The beautiful body lines are of the same character as the four-door closed cars. The body is finished in Duco of distinctive color, beautifully striped. The four-hinged doors are extra wide and passengers may get in and out of the back compartment without disturbing those in the front seat. Either one, or both, of the front seats may be folded entirely out of the way when desired. The upholstery is durable automobile material. The body is mounted on a 114 $\frac{3}{8}$ -inch wheelbase sealed chassis, with triple-sealed 60 h.p. McLaughlin-Buick Valve-in-Head engine. It is a distinct departure from the usual two-door type, and has the appearance of a car of much higher price. There is no greater value on the market.

connecting rods and the overhead valve mechanism. Every working part in the McLaughlin-Buick engine is lubricated from the main oil reservoir, eliminating the necessity for putting oil in any place excepting the crankcase.

Oil cushions make engine quiet

This complete lubrication accounts largely for the quietness of the McLaughlin-Buick engine. The rocker arms and push rods are lubricated by oil circulating under pressure through the rocker arm shaft. The oil is forced under pressure across the rocker arm to the ball and socket joint at the top of

the push rod. The socket or cup at the top of the push rod is constantly covered with a film of oil, which acts as a cushion between the cup and the rocker arm adjusting ball, so that there is no metal to metal contact. The result is quiet operation.

The oil, as it overflows from the cup, trickles down the side of the push rod, lubricating the lifter guide and roller. At this point there is a film of oil between the cam on the camshaft and the push rod roller. Any surplus oil drops into the crankcase.

This complete circulation of oil is illustrated on page 12.

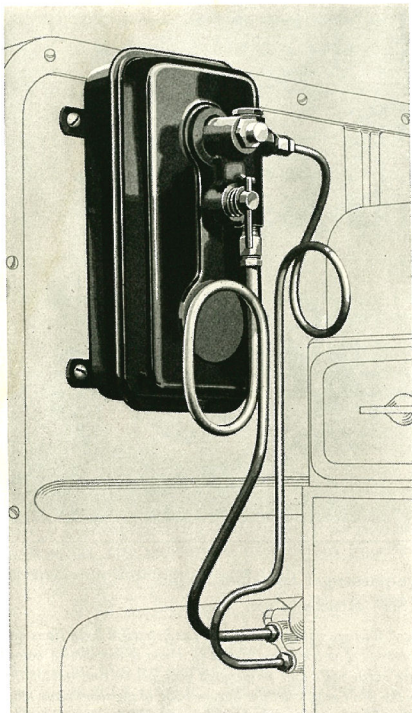

Exterior view of oil filter which cleans the oil of all sediment and foreign particles.

Interior view of oil filter showing nature of filtering cloths and screens which retain the dirt and let the oil pass through.

Turning the handle (A) permits oils to flow out at (B) if the oil filter is working. If the oil does not run out freely at (B), then the filter is not working properly. In this case the ball check valve (C) is forced down by the pressure of the oil, and oil flows to the outlet pipe without going through the filter, thus insuring lubrication of the engine under all conditions.

THE OIL PUMP

THE McLaughlin-Buick oil pump is located in the very lowest part of the oil reservoir at the bottom of the crank-case, insuring lubrication of the engine even though the oil supply should get very low. The pump is equipped with an auxiliary pipe through which oil is drawn if the screen becomes clogged, thus insuring proper lubrication of the engine at all times. The pump is of the positive gear type and is the most efficient known.

It relieves the owner of all worry about the lubrication of his car.

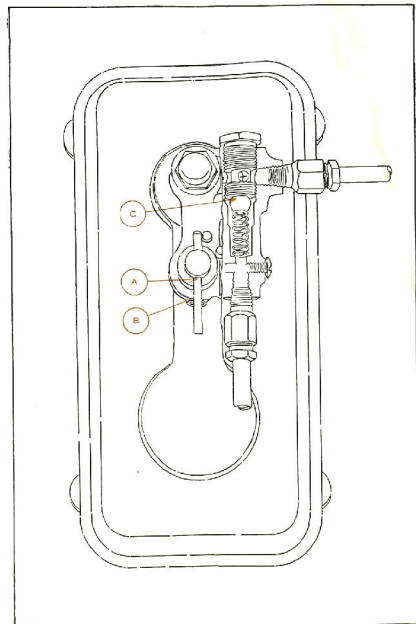
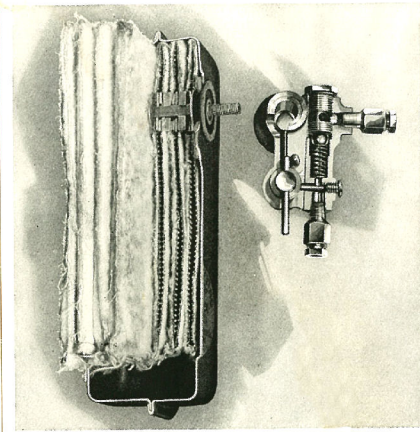

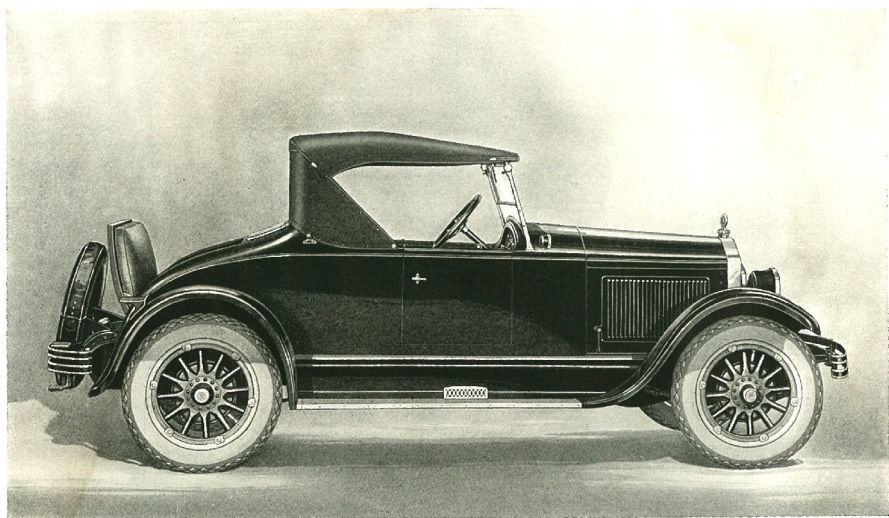

McLaughlin-Buick four-passenger Roadster

Special Six . Model 24



This popular roadster is unquestionably the outstanding value in its class. Among its distinctive features are long sweeping lines; heavy artillery wheels; neatly shaped folding top of heavy material; close fitting curtains with rigid frame, new design; front bumper, and bumperettes on the rear; deck bars, and side apron scuff plates. There is a comfortable, neatly folding Dickey seat in the rear deck which is large enough for two passengers, so arranged that it is easily accessible and has exceptional leg room for occupants. A foot rest is provided. The specially constructed seat cushion springs are upholstered in genuine Spanish leather, heavily padded. Motometer, rear-ision mirror, automatic wind-shield wiper, walnut steering wheel with polished spider, walnut control lever knob, nickel plated gear shift lever, tool pocket with lock in right front door are all Standard equipment. Like all McLaughlin-Buick Models this car has the famous sealed chassis with torque tube drive, McLaughlin-Buick triple-sealed Valve-in-Head 60 h.p. engine, and all those superior mechanical features for which McLaughlin-Buick is noted.

The chassis is lubricated by a pressure gun that forces the lubricant into the bearings under very

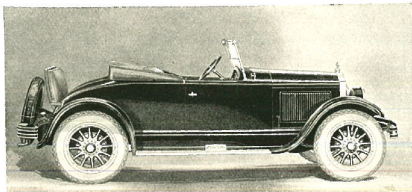

high pressure, insuring positive lubrication and elimination of the old lubricant.

McLaughlin-Buick engineers have reduced the lubrication of the McLaughlin-Buick car to the simplest point that is consistent with efficiency. All lubrication points have been made very accessible and very little attention from the owner is required to keep his car in first-class running condition.

THE FAN

THE McLaughlin-Buick fan is lubricated by a gear pump and oil reservoir located in the fan hub. It is seldom necessary to replenish or add to the oil supply oftener than every 15,000 or 20,000 miles.

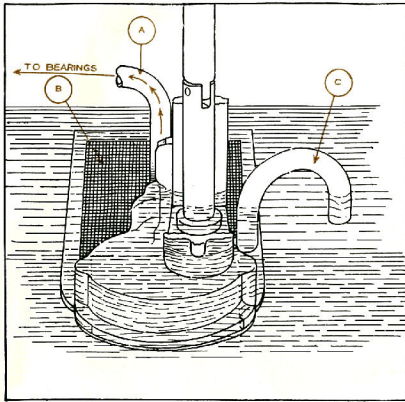
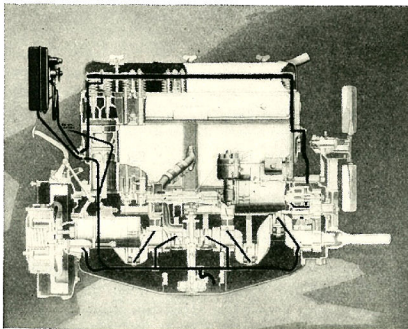
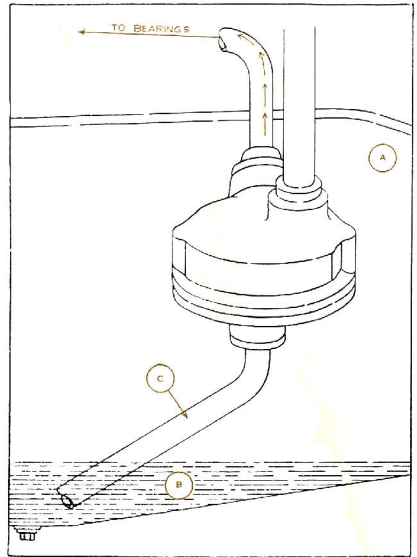
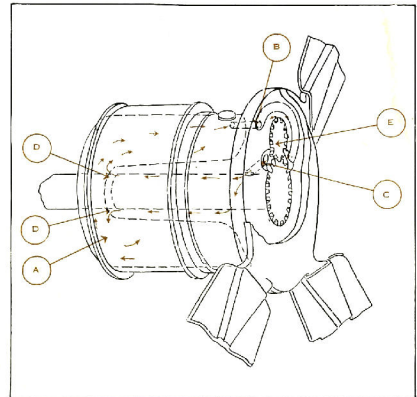

Diagram above illustrates the advantage of having the oil pump located at the lowest point in the oil reservoir, positively insuring lubrication of the engine even though the oil becomes extremely low. Oil is drawn by the pump through screen (B), forced under pressure through the pipe (A). Should the screen become clogged, oil is drawn through the by-pass pipe (C), then to the bearings through pipe (A). The oil flows through this by-pass pipe until the screen becomes clear and admits oil to the pump direct.

Diagram at right above illustrates less expensive method of mounting. In this type the pump is up on the side of the crankcase, and draws oil from the reservoir below through an extension pipe. It is less efficient, inasmuch as should the oil supply become low the pump is apt to lose its prime, especially after it has stood for a while, and if this occurred the engine would not be properly lubricated.



View of McLaughlin-Buick engine showing how oil circulates to all working parts under pressure from the oil pump located at lowest point in the oil reservoir at the bottom of the crankcase.



The McLaughlin-Buick fan with oil reservoir and gear pump in its hub (A)—Oil reservoir, (B) oil drawn from reservoir by gear pump, (C) oil forced to bearing by pump, (D) oil re-entering oil reservoir from the end of bearing, (E) gear pump.

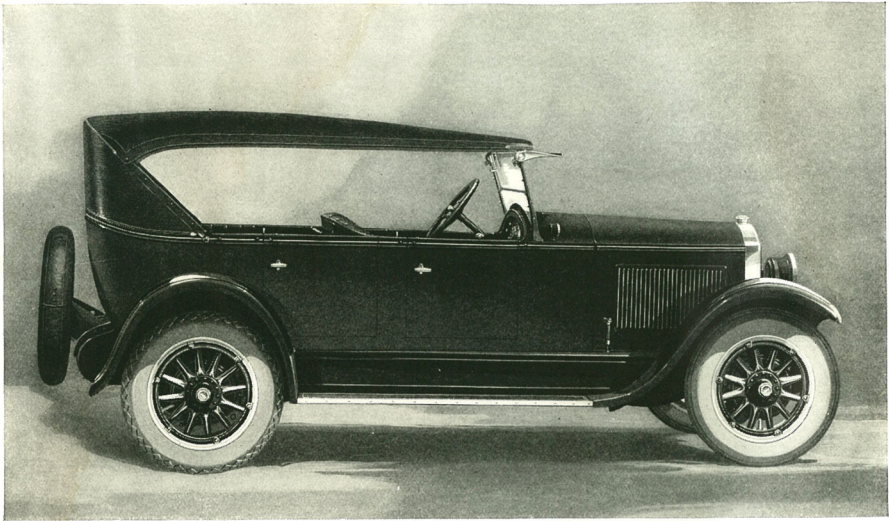

McLaughlin-Buick five-passenger Touring
Special Six . Model 25



This roomy, five-passenger McLaughlin-Buick is mounted on the McLaughlin-Buick Special Six sealed chassis, with the 60 h. p. triple-sealed McLaughlin-Buick Valve-in-Head engine. Low pressure tires and cantilever rear spring suspension provide easy and comfortable riding on all roads. The attractive Duco finish harmonizes with the low graceful permanent top. The interior is fully in keeping with this fine exterior appearance. It is upholstered in high grade leather. The tonneau is carpeted with neat, durable tapestry, and the front compartment with seamless, one-piece material that fits tightly around all levers and openings. The steering wheel is of generous size, with spark, gas, and headlight control levers. The rear window is extra large, and there is the same cowl ventilator that is found on all McLaughlin-Buick open models.

THE WATER PUMP

THE McLaughlin-Buick water pump is constructed so that there is only one packing nut, reducing to a minimum the possibility of the pump leaking. The pump shaft is hardened, ground and small in order to reduce the friction surface on the packing. Very flexible universal joints are provided to overcome the tendency of the shaft to run out of true, which practically eliminates pump trouble.

Efficient cooling is another reason for the McLaughlin-Buick's smooth performance.

VALVES ARE VERY ACCESSIBLE

A DISTINCT advantage in connection with the McLaughlin-Buick Valve-in-Head type of engine construction is the accessibility of the valves for adjusting and grinding.

Simply removing the valve cover exposes the valves, and they may then be easily adjusted with a screw driver and a small wrench.

Grinding valves, which is seldom necessary on a McLaughlin-Buick, is also a simple operation. Removal of a few studs makes it possible to lift the

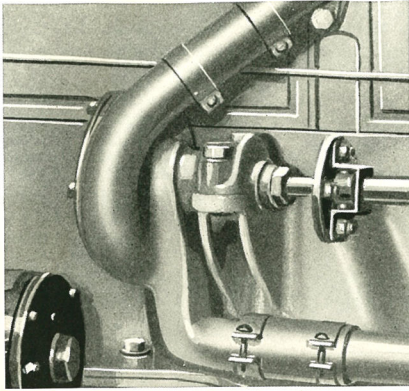

The newly designed water pump with only one packing nut. It is especially constructed to reduce wear, which is easily taken up by a slight turn on the packing nut.

head, in which the valves are assembled, off the block. This operation also exposes the entire combustion chamber and the heads of the pistons. This is a great saving of time and expense in comparison with other types and is another example of the excess value that is built into every part of the McLaughlin-Buick in order that the McLaughlin-Buick owner may enjoy the fullest return for his investment.

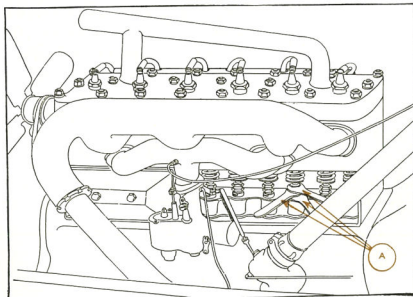

In the L-head engine the valves are very inaccessible for adjusting and grinding. To adjust the valves three wrenches (A) are required. Note that it is necessary to work around and behind the steering post, carburetor, and manifolds. For grinding, the valves must be removed entirely, which is a difficult job compared to removing the valves from the McLaughlin-Buick Valve-in-Head engine.

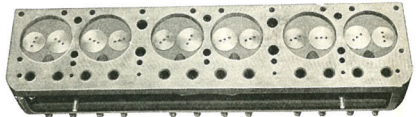
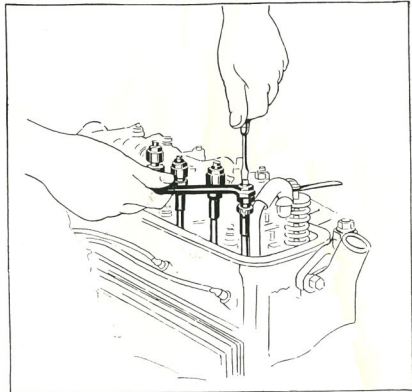
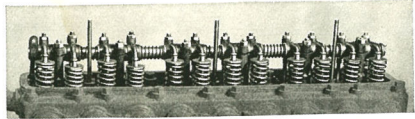

To adjust the valves on a McLaughlin-Buick Valve-in-Head engine it is only necessary to remove three nuts, lift off the cover and expose the valves. There are no obstructions whatever, and the valves may be adjusted with a small screwdriver and one wrench. To grind the valves a few other nuts are removed and the entire head, containing all the valves, may then be lifted off. At the same time this exposes the entire combustion chamber and the tops of the pistons.

CORRECT BALANCE—SMOOTH OPERATION

THE crankshaft, flywheel, connecting rods, and pistons in the McLaughlin-Buick Valve-in-Head engine are correctly balanced.

The crankshaft has four large bearing surfaces, insuring a smooth running engine.

Due to the correct balance and size of these parts, it is not necessary to use more or larger bearing surfaces to prevent the crankshaft from running out of true, or whipping, with consequent jerky or uneven performance of the engine.

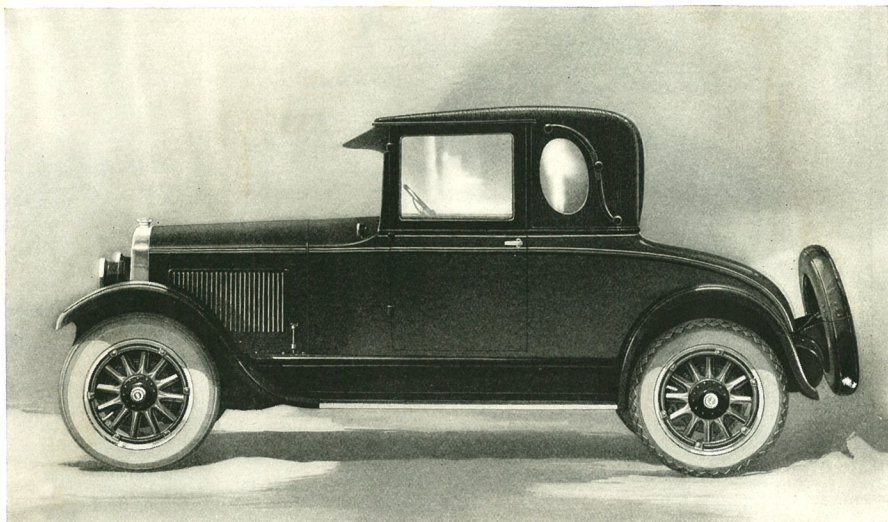

McLaughlin-Buick two-passenger Coupe
Special Six . Model 26



This extremely attractive Coupe is finished in Duco of attractive color, with contrasting striping that gives it a dashing and smart appearance. The brougham type top is of bright finish, long-grain leather. The slightly tilted, oval rear side windows add to the pleasing effect. The car is upholstered in durable plush, the side and head linings being a harmonizing color. A lever in the center of the steering wheel controls the new double-focus headlights, with which all McLaughlin-Buick models are equipped. The rear deck door has spring hinges and gives easy access to the rear compartment. The wheels are the heavy artillery type, and are fitted with low-pressure tires which with the cantilever rear springs provide a riding comfort that is only to be found in a McLaughlin-Buick.

In the McLaughlin-Buick engine any additional bearing surfaces would be superfluous. Only a sufficient amount of bearing surface to insure the engine running smoothly at all speeds is necessary. If the McLaughlin-Buick crankshaft were smaller and lighter more bearings would be necessary in order to hold it from whipping out of line. Only a sufficient amount of bearing surface is needed, which, together with a properly designed and balanced crankshaft, flywheel, clutch, connecting rods and pistons, will insure smooth operation. When the crankshaft is of the proper size as it is in the McLaughlin-Buick, more bearings, an

additional flywheel or a stabilizer are not necessary. The desirable combination that is found in the McLaughlin-Buick engine accounts for its smooth-running performance at all speeds.

CAST IRON PISTONS

THE pistons used in McLaughlin-Buick cars are made of cast iron, which is the same material that is used in the manufacture of the cylinder block. Therefore both have the same ratio of contraction and expansion, which permits fitting of the pistons close enough to eliminate piston slap, without danger of seizing.



The convenient handle for opening the door.

McLaughlin-Buick pistons will, with ordinary care and under ordinary driving conditions, last the lifetime of the engine.

After exhaustive tests and experiments over a number of years, McLaughlin-Buick engineers, in collaboration with the General Motors Corporation laboratories, have failed to find any piston material

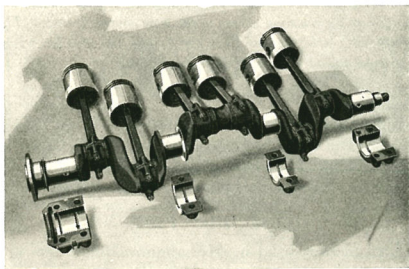

The heavy, drop-forged McLaughlin-Buick crankshaft with four large bearings, drop-forged connecting rods, and cast iron pistons. The crankshaft, connecting rods, pistons, flywheel, and clutch are properly designed and balanced. This eliminates the necessity for a greater number of bearings, additional flywheel, or stabilizer, which would be required if McLaughlin-Buick used less care or expense in designing and manufacturing these important parts of the engine.

The rocker arm shaft (A) and the rocker arms (B) are lubricated by oil circulating under pressure through the rocker arm shaft. The socket or cup (C) at the top of the push rod (D) retains a film or cushion of oil. The oil then flows down the sides of push rod, lubricating the lifter (E) and forming a film of oil between the cam roller (F) and the cam (G). Oil is also drawn through the rocker arm at (H) forming a film of oil at (I). It then flows down the valve stem, lubricating the valve stem guide (J). All metal to metal contact is eliminated and quietness is assured.

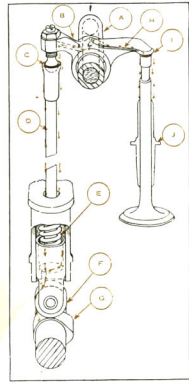

that will give as satisfactory results as cast iron. Manufacturers of other materials recommended for pistons have worked with McLaughlin-Buick and General Motors in an effort to prove that their material is as satisfactory, but this was not found to be true.

With McLaughlin-Buick's policy of putting into its product material that will render the most satisfactory service, you may be sure that if there were some other material for pistons that would prove of advantage over cast iron, it would be found in the McLaughlin-Buick car.

Side sectional view of a cylinder from the McLaughlin-Buick Valve-in-Head engine. Note that the valves (A) are in a straight line above the pistons (B) in the center of the combustion chamber (C). Exhaust gases are quickly and easily expelled and there is a minimum of water-jacketed space (D). In the McLaughlin-Buick Valve-in-Head engine there is from 50 to 65 per cent less water-jacketed space than in the L-head engine. Hence there is much less opportunity for the heat, which is power, escaping into the water-jacketed surfaces. This is one of the reasons for the greater power of the McLaughlin-Buick Valve-in-Head engine.

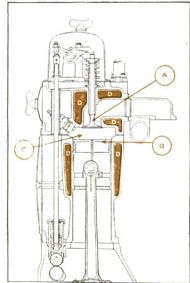

Side sectional view of an L-head cylinder. The valves (A) are located at the side of the combustion chamber (B). The pistons (C) being at the other side of the combustion chamber, the exhaust gases are not as easily expelled, because they are not forced out in an upward direction. Note the large water-jacketing surface (D) that is required—from 50 to 65 per cent more than in the McLaughlin-Buick.

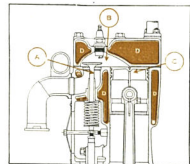

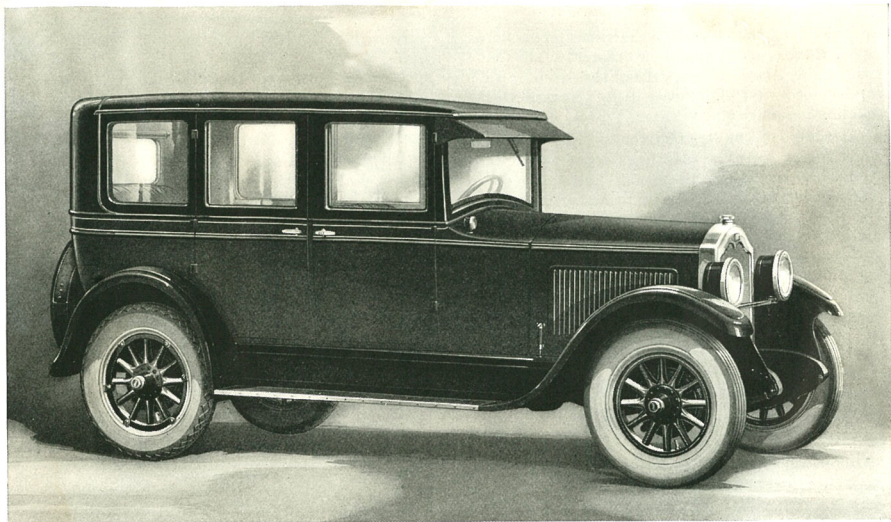

McLaughlin-Buick five-passenger Sedan
Special Six . Model 27



This McLaughlin-Buick model has a low, graceful appearance. Its Duco finished body is given a pleasing contrast by the heavy moldings and beautiful striping that extend completely around the body. The seats are low and very comfortable, with generous headroom. The seat cushions and backs are upholstered in durable plush. The side and head linings harmonize with the interior. The rear compartment is carpeted with a new type hair and wool material, with rubber-covered back. Rear and side windows have roller curtains. All windows are generous in size and greatly enhance the exterior appearance. The body is mounted on the McLaughlin-Buick Special Six chassis, with all its desirable mechanical features. The triple-sealed 60 h. p. McLaughlin-Buick Valve-in-Head engine furnishes a surplus of power and speed.

MORE POWER—LESS GASOLINE

INTERNAL combustion engines are all heat engines. In other words, they develop their power by converting the fuel used in operating them into heat. It is the expansion of the heated gases resulting from each explosion in the cylinders that supplies the impulses necessary to run the engine.

So, as far as the engine is concerned, a gallon of gasoline represents so many heat units, and the greater the percentage of these heat units that can be converted into actual working power, the greater

the efficiency—or economy—of the engine will be. Unfortunately it is impracticable to use all of the heat generated in such an engine for power, because unless some means of cooling the engine is used, the heat soon becomes so great as to be destructive.

The less water-jacketing the better

So, in making the cylinder castings, water passages are cast around the cylinders in such a manner as to allow the excess heat to escape through the cylinder walls into the water, which in turn is cooled by the radiator on the front of the car. It is

quite evident, therefore, that the less water-jacketed space there is in an engine, the greater the efficiency will be, because a smaller area of the cylinder walls and combustion chamber will be exposed to the cooling influence of the water.

It should be understood that in all cases both inlet and exhaust valves form a part of the combustion chamber, where the heat is greatest, and in consequence it is necessary to water-jacket the valve chambers as well as the tops and sides of the cylinders.

In some engines there is a large pocket on the side of each cylinder in which the valves are located. This pocket is water-jacketed.

In the McLaughlin-Buick Valve-in-Head engine there is just a plain, unbroken cylinder, with the valves located in the head of the cylinder. And as this space is already water-jacketed it follows that the McLaughlin-Buick Valve-in-Head engine affords the minimum of water-jacketed space that is possible to be secured for any given size of cylinder. This has an important bearing on the efficiency of the engine.

Now, if we regard our gasoline as so many heat units, it is quite apparent that the fewer of these heat units that are wasted through the water-jacketed surfaces, the more of them will be left in the form of actual usable power directed against the pistons.

Then because the big valves in the McLaughlin-Buick Valve-in-Head engine are located in a straight line above the pistons, the dead exhaust gases are quickly and easily expelled through them at the conclusion of the power stroke, instead of being forced around corners and downward through a much larger chamber, as in some other types of engines.

Why the McLaughlin-Buick engine is most efficient

The net results of these main characteristics of design are to give the McLaughlin-Buick Valve-in-Head engine more perfect combustion than any other type of engine, a quicker ignition of the charge and a smaller loss of heat through the water-jackets. The sum of these advantages in design is more power with less gasoline consumption.

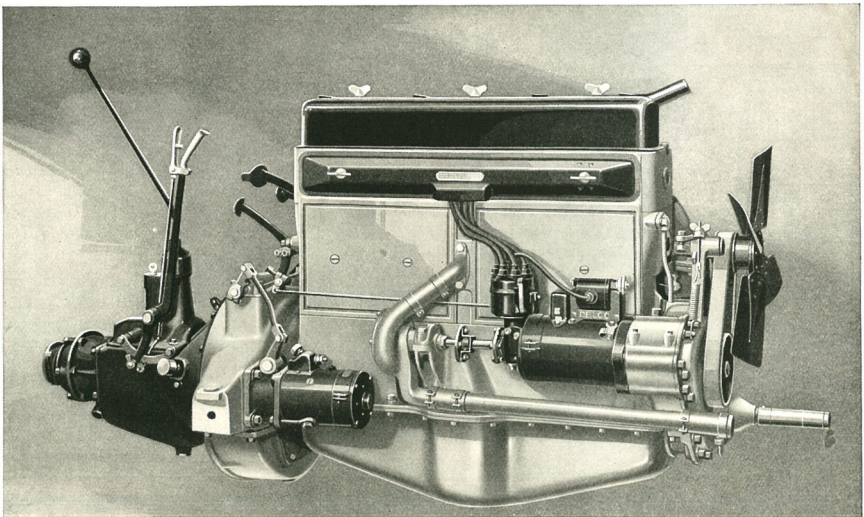

Right hand side of the McLaughlin-Buick Valve-in-Head engine. Special Six, 60 h.p. Master Six, 75 h.p.

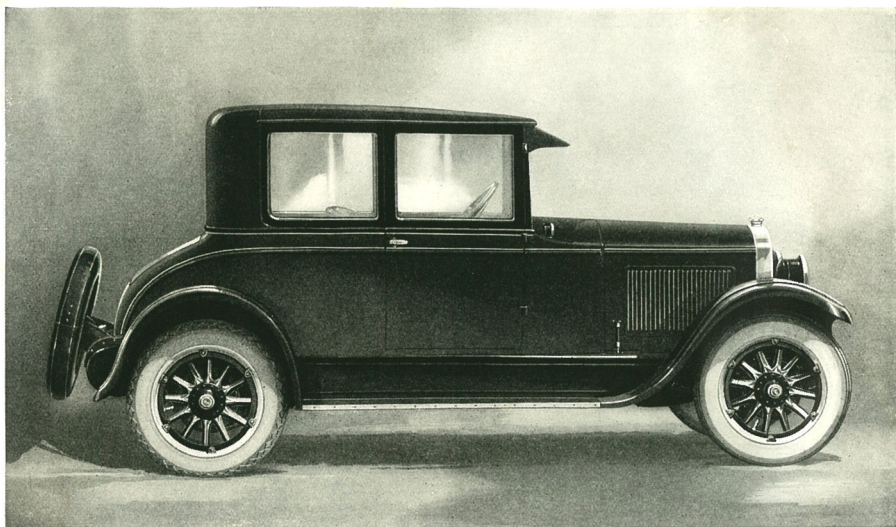

McLaughlin-Buick four-passenger Coupe
Special Six . Model 28



This entirely new four-passenger Coupe is extremely smart in appearance, exceptionally large and roomy, and well balanced. The low roof line and the gracefully curved rear corners are of the same design as other McLaughlin-Buick closed models. There are four large side windows, and an extra large rear window. There are roller curtains on the rear and the rear side windows. The rear deck is large and the door springs open when unlocked. The driver's seat is wide, deep and comfortable. The passenger seat is generously large for two, and the comfortably proportioned extra seat folds out of the way when not needed. The body is finished in Duco and is beautifully striped, with wheels to match. There are many other features. This car, like other McLaughlin-Buick models, must be seen to be appreciated.

THE McLAUGHLIN-BUICK STARTER

THE Delco starting motor is of the positive mechanical type. Pressing down on the starting pedal pushes the starting gear into mesh with the teeth on the flywheel before the starting motor gets into operation.

After the starting and flywheel gears are in mesh, a contact is formed with the switch mounted on top of the starting motor. This completes the starting motor circuit to the battery in a direct and positive manner, providing fast cranking of the engine, with

greater break-away torque, insuring effective starting, especially in extremely cold weather.

The starter pinion is equipped with an over-running clutch which allows the flywheel to run ahead of the starting motor when the engine starts.

The flywheel teeth are cut in a special hardened steel ring, with teeth chamfered for easy engagement with the starter. This ring is shrunk on to the flywheel, thus providing extra strength.

The starting motor is a separate unit from the generator. It is very powerful, positive in action, and practically trouble-proof.

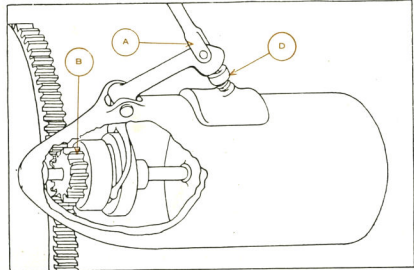
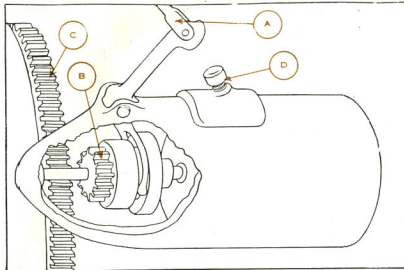

Diagrams illustrating the operation of the McLaughlin-Buick starter. Pressing on the starter pedal on other end of rod (A) pushes the gear on the starter motor shaft (D) into mesh with the teeth on the flywheel (C). Further depression of the pedal makes a contact with the switch button (D) on the starter motor. This puts the starter motor in

operation and turns the engine. Note that the starter motor cannot be in operation and the gear (B) does not begin to turn until it is in mesh with the teeth on the flywheel. This insures smooth operation without clashing of gears, and practically eliminates the breaking of teeth on the flywheel.

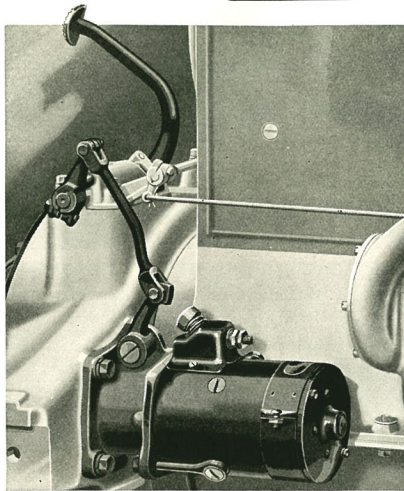

The Delco electric starting motor of very latest type and design, insuring rapid turnover of the engine, a quick start at all times.

Diagrams illustrating the operation of a less expensive type of starter. Pressing on the starter button (A) immediately puts the starting motor in operation. The gear on the starter shaft (B) travels on worm (C) until it is in mesh with the teeth on the flywheel. There is a great possibility, however, of this gear not meshing readily in spite of

a counterbalance intended to keep the gear from rotating until it is in mesh; heavy grease on the worm may cause the gear to spin, making it difficult to force it into place with the power of the starter. This results in clashing gears (D) and the possibility of breaking teeth on the flywheel.

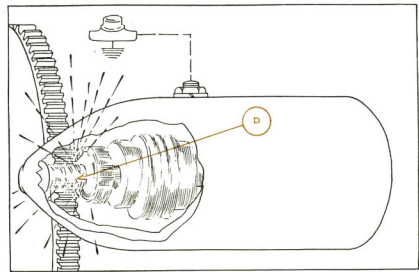
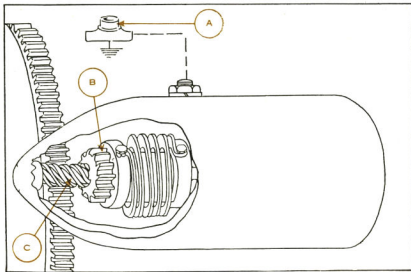

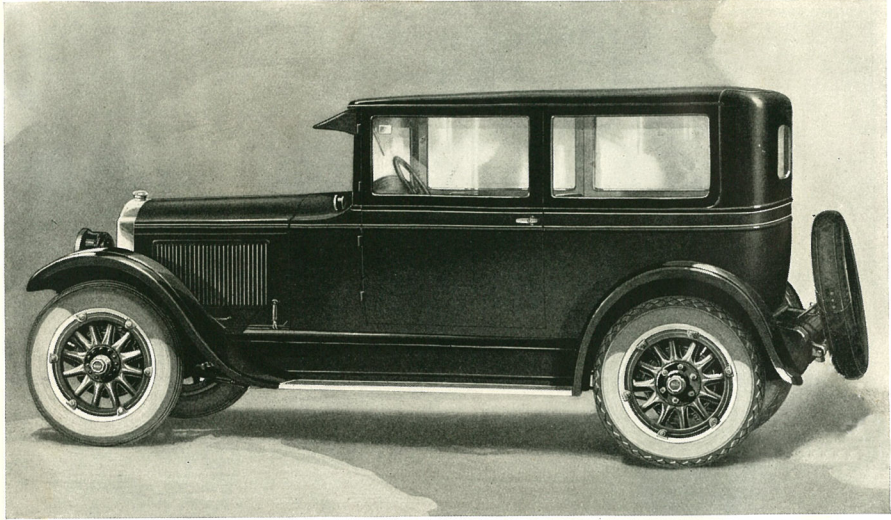

McLaughlin-Buick five-passenger two-door Sedan
Master Six . Model 40

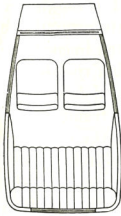

This large, five passenger, two-door Sedan unquestionably sets a new standard of value for automobiles of the two-door type. Its beautiful body lines, and its low roof line, ending in pleasing, curved rear corners, mark it as a leader among the handsomest closed cars on the market. The body is finished in Duco of a rich and most pleasing color. Heavy moldings, running entirely around the body, and harmonious striping tend to make it look even lower than it is. The body is mounted on the McLaughlin-Buick Master Six sealed chassis, with a 75 h. p. triple-sealed McLaughlin-Buick Valve-in-Head engine; McLaughlin-Buick torque tube drive; McLaughlin-Buick four-wheel brakes, and all the other mechanical features described in this book. In comparison, this, like the other McLaughlin-Buicks, is a two-dollar value for every dollar invested.

THE GENERATOR

THE generator on McLaughlin-Buick models is driven direct by the timing gears. It is very compact and efficient. It is equipped with a cut-out relay, which automatically disconnects the generator from the battery when it is not being driven at a charging speed.

This prevents discharging the battery when the engine is idling or running slowly.

All high tension connections on the distributor and coil are in rubber ferrules, eliminating the possibility of water getting into the connections and

causing short circuits. This Delco generator is of the very latest type and design. It is built as an integral part of the McLaughlin-Buick Valve-in-Head engine and insures efficient operation.

THE CARBURETOR

THE McLaughlin-Buick carburetor and manifold are of an improved type, of large size, to insure the most efficient mixture of gasoline and air in proper quantity for the powerful McLaughlin-Buick Valve-in-Head engine.

Improvements that have been made in the carburetion and manifold system are partly respon-

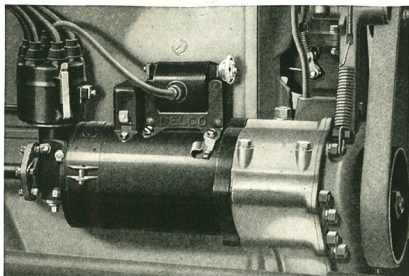

The Delco generator, with distributor and coil built as integral parts, providing current for lighting and ignition and keeping the storage battery properly charged. It is positively driven by the timing gears, quiet in operation, and trouble-proof. It is so designed that it is automatically disconnected from the battery when not traveling at charging rate, in order to prevent discharging the battery.

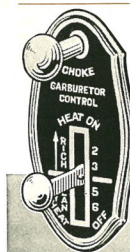

This device on the dash board affords manual control of the heat to the carburetor as described in the accompanying article. When the engine is cold starting choke button should be pulled out before starting, and pushed partly in when the engine starts. It should be pushed all the way in as soon as the engine is running evenly. In most instances the choke can be pushed all the way in after driving a few blocks.

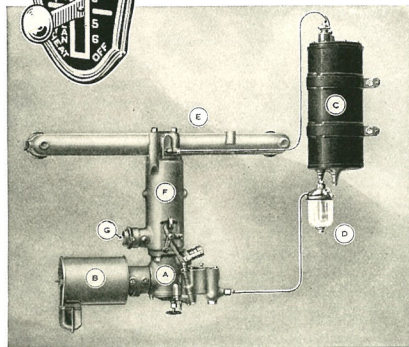

Much of the great power of the McLaughlin-Buick Valve-in-Head engines is due to the correct design of the carburetor and manifold system. This illustration shows the carburetor (A) with the air cleaner (B), which removes all dirt; the vacuum tank (C), with gasoline filter (D); the inlet manifold (E); and the carburetor riser (F) connecting the carburetor with the inlet manifold. Heat from the exhaust pipe enters at (G) and heats the gas to a proper temperature as it rises from the carburetor to the inlet manifold. In this system the heat is regulated automatically, according to the speed of the engine. There is more heat in starting and at low speeds, and less heat as the speed increases, thus preventing overheating of the gas mixture before it enters the cylinders.

sible for the increased power and efficiency of the McLaughlin-Buick Valve-in-Head engines.

The increased efficiency of the carburetion system, together with the gasoline filter, air cleaner, and oil filter, provide features that mean more power and more speed, with their resultant increase in the pleasure of driving, and reduce to a minimum service expense in connection with the engine.

CARBURETOR HEAT CONTROL

AUTOMATIC heat control on McLaughlin-Buick engines insures easy starting, quick warm-up, and good distribution of gas into the cylinders.

In this system the heat from the exhaust gases is diverted around the chamber immediately above the carburetor, heating the gas formed by the mixture of air and gasoline as it leaves the carburetor and enters this chamber.

The valve that diverts the gas from the exhaust manifold around the carburetor opens and closes as the speed of the engine increases or decreases. In starting, and when the engine is running slowly, practically all the heat passes around the carburetor.

As the engine speed increases this valve opens and heat is permitted to pass out through the exhaust pipe, and does not circulate around the carburetor. If the heat were permitted to continue to pass around the carburetor at high speeds, the gas mixture would become too hot, and deteriorate in its power-producing qualities, with resultant loss of power at high speeds, and when the engine is pulling hard through mud or sand, or on long hills.

There is a manual control for the heat on the instrument board, but regardless of this control, the heat is automatically regulated by the speed of the engine. The valve in the exhaust manifold which directs the heat either around the carburetor or on through the manifold, is connected with the accelerator lever, and is forced into open position as the acceleration is advanced.

Operating the manual control

The control on the dash should be at "heat on" position at all times when driving in traffic. Practically the only function of this control on the instrument board is to regulate the time at which the heat is cut off from the carburetor.

With this regulator in "medium" position, the

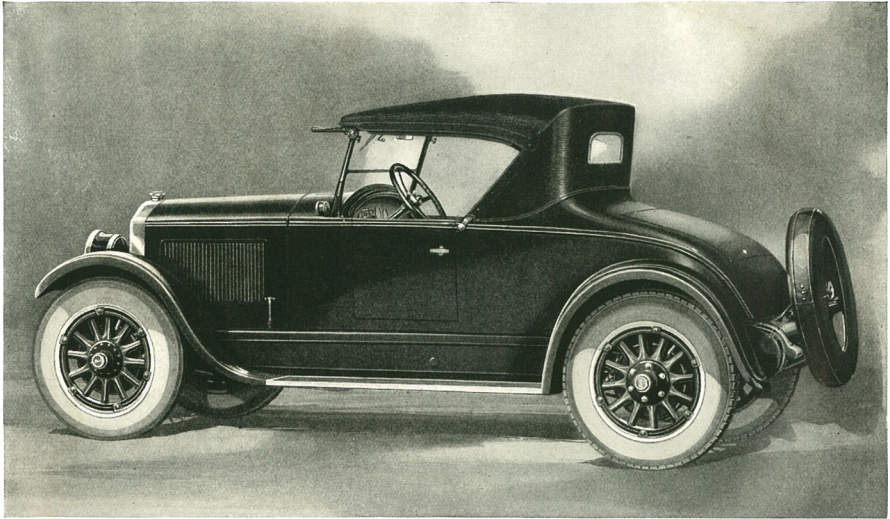

McLaughlin-Buick two-passenger Roadster
Master Six . Model 44



This two-passenger Roadster is finished in Duco of a most pleasing color, with wheels to match. The prominent and pleasingly curved moldings are in contrasting colors. The permanent top is covered with a rich-looking material and has a brown and white whipcord lining. Tight-fitting storm curtains, with large window lights, are provided, and the fitting of winter enclosures is both easy and practical. It is upholstered in high grade leather. The wheelbase is 120 inches. The chassis is completely sealed and is powered with a 75 h. p. triple-sealed McLaughlin-Buick Valve-in-Head engine, triple-sealed meaning that the air, the gasoline, and the oil are cleaned. Those lovers of open models, of whom there are many, will be particularly pleased with this model.

valve regulating the heat opens at a lower speed than when at "heat on" position.

With this control in "heat off" position, or all the way down, the valve is not entirely closed, allowing some heat to pass around the carburetor, and some to pass out through the manifold. This is at low speed. But at higher speeds it cuts out the heat from the carburetor entirely, just as it does at the other positions.

A simple rule to follow in connection with this heat regulator is: When driving in traffic have the lever at "heat on" or near to it. For country driving

pull the lever down to "medium" or "heat off," according to the weather. There is no difference in gasoline consumption regardless of the position of this heat control lever on the instrument board.

THE McLAUGHLIN-BUICK RADIATOR

THE Harrison cellular type radiator is used on the McLaughlin-Buick because it is the most efficient. It is so mounted on the radiator support that the core is relieved of all strains and the possibility of the radiator leaking is reduced to a minimum.

The design of the radiator [continued on page 26]

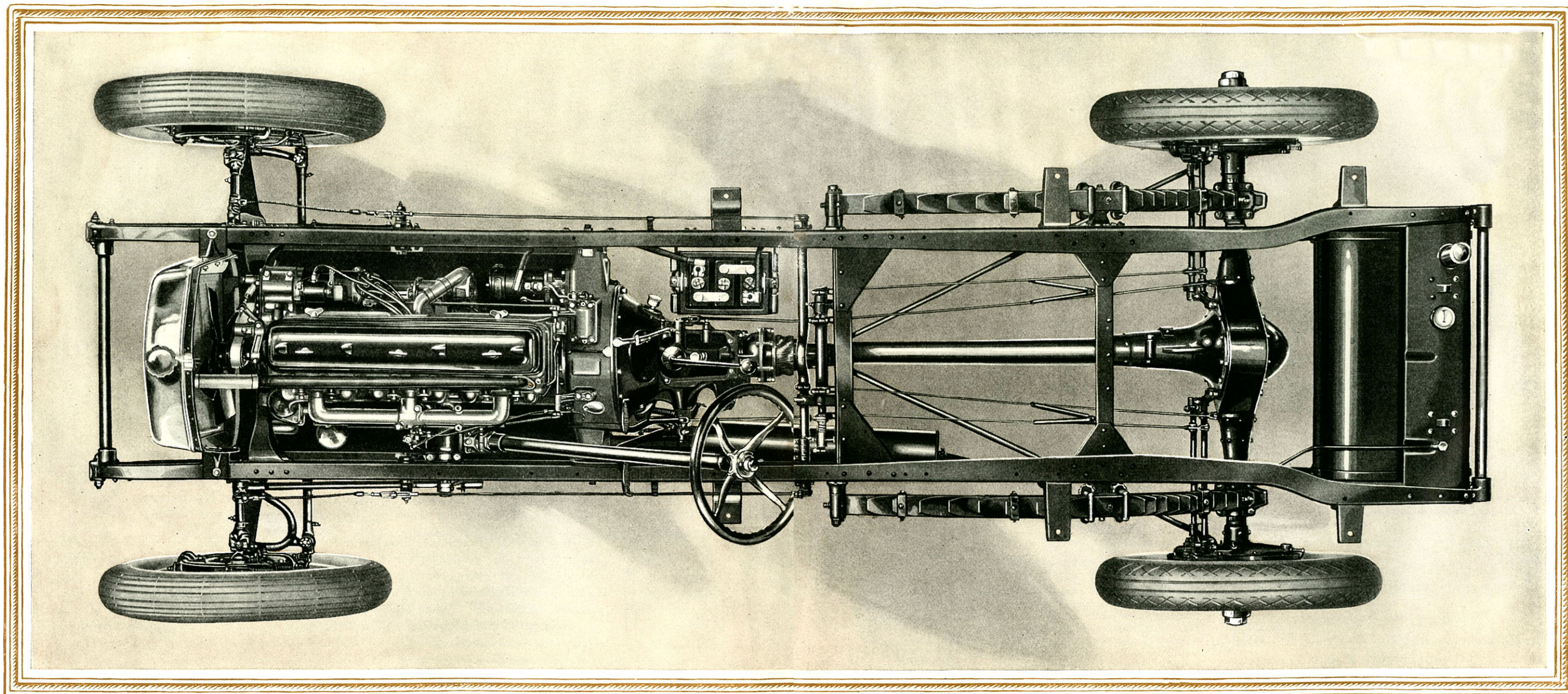

THE McLAUGHLIN-BUICK SEALED CHASSIS WITH TRIPLE-SEALED ENGINE

THE McLaughlin-Buick chassis is noted for its rigid and substantial construction. Every part of it is designed by the McLaughlin-Buick engineering department, which is one of the largest, if not the largest, maintained by any automobile manufacturers. This absolutely insures coordination of all units, and makes certain that each will perform in accordance with the burdens that it is called upon to bear.

The chassis consists of the following units:

1. McLaughlin-Buick triple-sealed Valve-in-Head engine, with clutch and transmission built integral, forming one unit.
2. McLaughlin-Buick torque tube drive and floating type rear axles, with one universal joint.
3. Cantilever rear springs and semi-elliptic front springs.
4. Drop-forged, I-beam front axles.
5. Strong, substantial frame, with six extra brackets for mounting closed bodies.
6. Gasoline tank of large capacity.
7. Heavy, artillery type wood wheels.
8. Beautifully designed and extremely efficient Harrison type radiator.

This chassis is completely sealed, absolutely insuring the elimination of all dirt, grit, and other foreign matter from the bearings and working parts, and retaining lubricant.

To this sealed chassis have been added triple seals on the engine, which clean the air, clean the gasoline, and clean the oil, keeping them free from all foreign matter, when they enter the working parts of the engine.

The chassis is the most important part of an automobile. The most beautiful body, complete in its appointments and refinements, mounted on a chassis in-

correctly designed, and inefficiently built, would not provide a satisfactory automobile.

McLaughlin-Buick lays particular stress upon its correctly designed, engineered, and built chassis. Upon it are offered sixteen different body types, most beautifully and symmetrically designed, handsomely finished and upholstered, and fitted with appointments of convenience specially suitable to each type.

It has been fittingly said that: "When better automobiles are built, McLaughlin-Buick will build them," and "regardless of the car you buy, or the price you pay, there is no greater value than a McLaughlin-Buick."

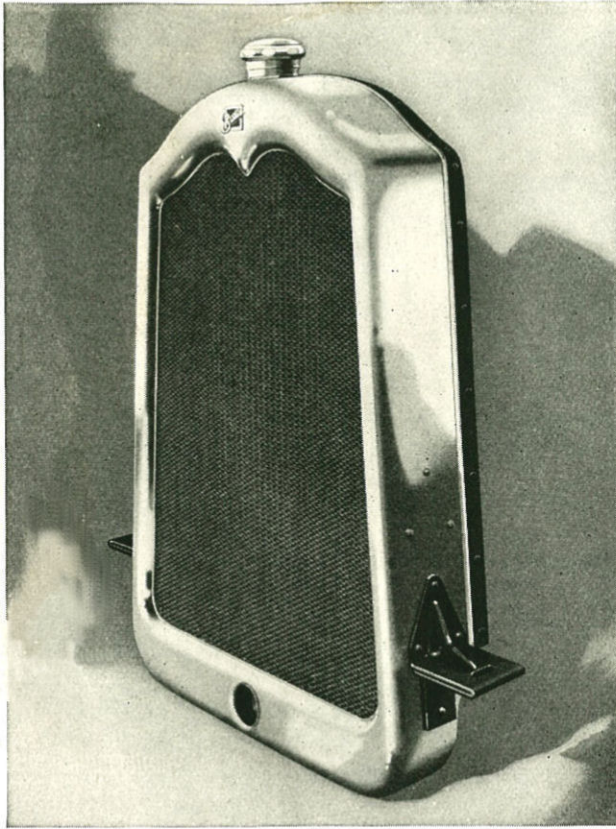

The McLaughlin-Buick Harrison type radiator with radiator shell of improved and more pleasing design. The corners are slightly rounded and there is a crown front.

shell has been made still more distinctive by rounding the corners and slightly crowning the front.

Harrison type is most efficient

The Harrison type radiator is so constructed that the water flows down through it in an irregular course. The air as it is drawn through by the fan is broken up by striking irregular fins, and for this reason it does not become warm, but carries its cooling properties through the entire thickness of the radiator. It is much more expensive to build than other types, but is much more efficient.

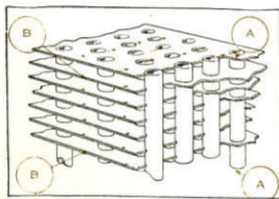

In the tubular type radiator. The water falls in a straight line through the tube (A) and the air drawn through the spaces (B) has less cooling effect because there is less radiating surface owing to the difficulty of forming perfectly soldered joints between the tubes (A) and the cross sections.

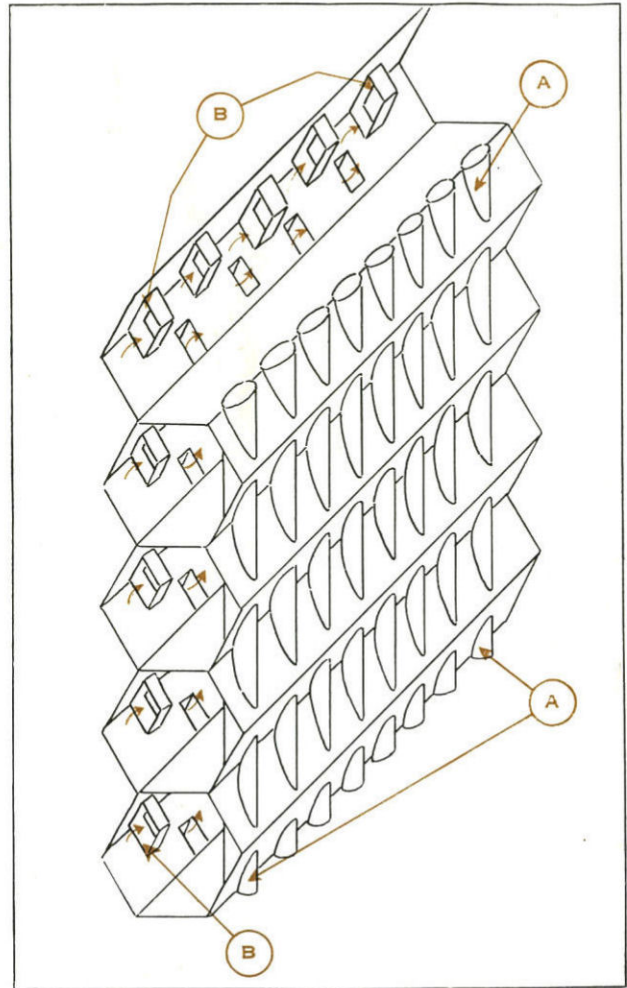

Sectional view of the McLaughlin-Buick radiator. The water is carried in an irregular course through the many cells (A). The large number of radiating fins (B) are cooled by the air as it is drawn through by the fan. These radiating fins are staggered so that the air is broken up as it passes through. These fins provide a large radiating surface, and the air in its irregular course through the air chambers retains its cooling efficiency for the entire thickness of the radiator.

The tubular type radiator

The tubular type of radiator is less expensive to manufacture and likewise less efficient. The water falls in a straight line through tubes. The cross sections that hold the tubes in place are to radiate the heat, but it is extremely difficult to get them solidly soldered to the tubes. As a result there are air spaces where the solder does not fill up and the heat cannot radiate to the supporting section. A very large radiating surface is needed to give sufficient cooling.

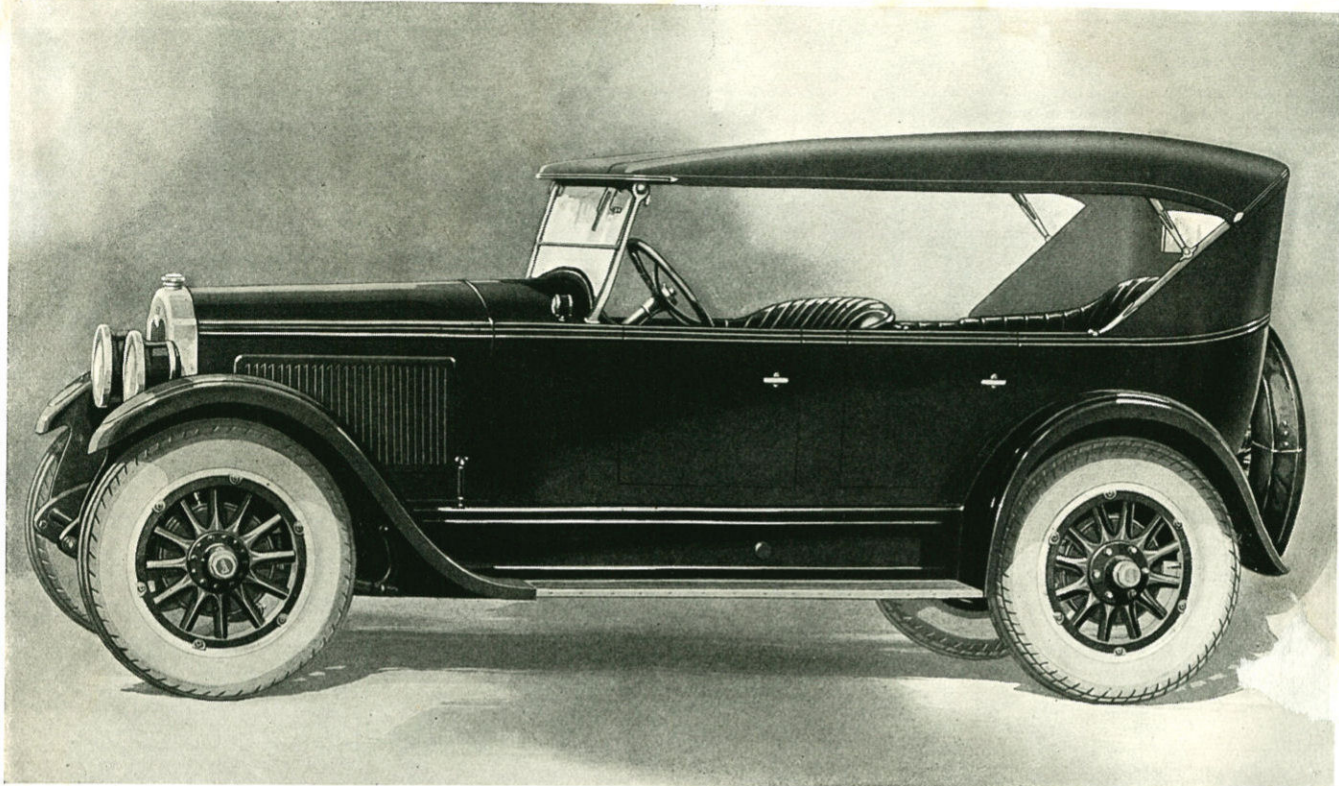

McLaughlin-Buick five-passenger Touring
Master Six . Model 45



Here is a large, roomy, five-passenger Touring with gracefulness of body lines, and richness of interior and exterior finish that mark it with distinction in any group of automobiles. The body is finished in Duco with wheels to match. Molding and striping extend in a graceful line from the radiator clear around the body. The top has natural wood bows with nickel slat irons and tight fitting curtains and is covered with heavy Black Top material. The seats are covered with high grade genuine leather and are arranged to afford extra leg room. Rear-vision mirror and windshield wiper, are included in the equipment. Like all the other McLaughlin-Buick models, this car has the large nickel radiator of new design.

MULTIPLE DISC CLUTCH

THE McLaughlin-Buick clutch is the multiple disc dry plate type. It has ten friction surfaces, which give it a soft action, requiring but slight pedal pressure. Because it is always in running balance the result is smooth engagement and rapid pick-up.

All the rotating parts are light. Therefore when the clutch is disengaged they quickly stop spinning, permitting of very easy gear shift. This is also the reason why the gears on a McLaughlin-Buick shift so quietly.

There is only one clutch release spring, which is

located in the center, insuring even distribution of pressure. Because of the many friction surfaces this spring is light. In a single plate clutch the small amount of friction surface necessitates very heavy clutch springs, and much more pressure is required to disengage the clutch.

Adjustment of the McLaughlin-Buick multiple disc clutch is very simple and is made at one point—directly underneath the floor boards in the front compartment. Merely turning the adjusting screw adjusts the plates evenly over their whole contact surface. Without question the McLaughlin-Buick clutch is the most positive in action, and requires

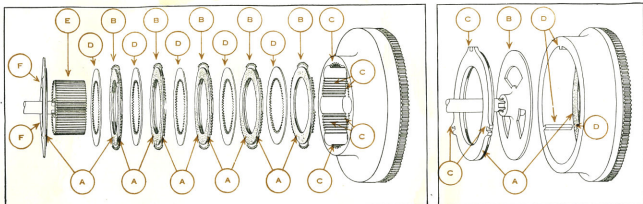
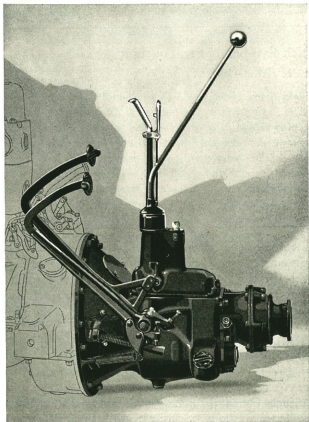

Diagram above shows the parts which make up the McLaughlin-Buick multiple disc clutch. The ten friction surfaces are marked (A). The driving plates are indicated by (B), the teeth on the outer edge fitting into the teeth on the inside of the flywheel (C). The driven plates (D), with teeth on inside, fit into the teeth on the clutch hub (E). Pressure on the clutch pedal separates the driving plates from the driven plates and so disconnects the power of the engine from the transmission. When the pressure is removed from the clutch pedal the clutch spring bearing on the plate (F) forces the plates together. The friction surfaces grip the driven plates and transmit the power of the engine to the transmission. The action of this clutch is smooth and positive. The large friction

area eliminates the need for heavy clutch springs, accounting for the slight pressure required to disengage the clutch.

Diagram at right illustrates the action of the single plate type of clutch. This type is much less expensive, but is not so smooth in action. It requires much more pressure to disengage it because of the heavy clutch springs, which are necessary to compensate for the small friction area, indicated by (A). The driven plate is indicated by (B). The slots (C) in the driving plate fit into the lugs (D) in the flywheel. This clutch is adjusted at four points and it is much harder to secure even pressure than with the McLaughlin-Buick multiple disc clutch which is adjusted at one point only.



The McLaughlin-Buick transmission.

the least effort to operate of any clutch known. The ease of operation of the clutch and the easy manner in which the McLaughlin-Buick car steers provide comfort in driving that has made McLaughlin-Buick extremely popular, especially with women.

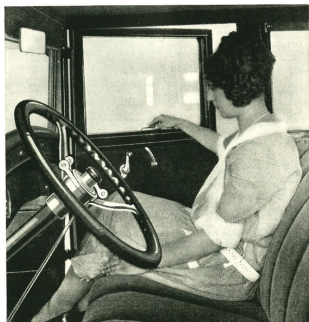

The convenient handle for pulling the door shut on closed models.

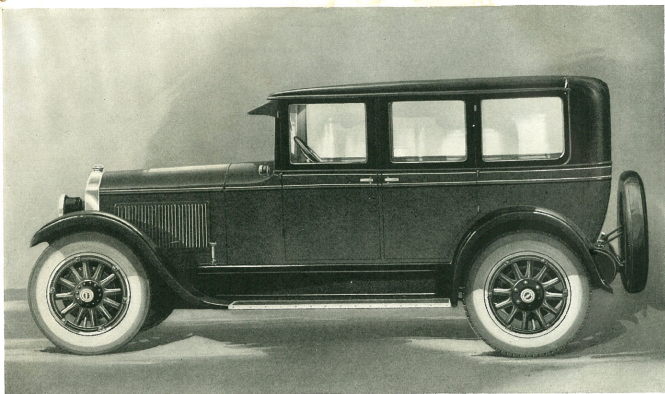

McLaughlin-Buick five-passenger four-door Sedan
Master Six . Model 47



Here is a five-passenger four-door Sedan that in graceful design and beauty of exterior and interior finish can only be equalled by another McLaughlin-Buick. It is mounted on the McLaughlin-Buick Master Six chassis, with the 75 h.p. triple-sealed McLaughlin-Buick Valve-in-Head engine. It is long and low, and is handsomely finished in Duco. The roomy interior, with low, comfortable seats, is finished in plush of harmonizing colors, and the floors are neatly covered. It has a generous sized steering wheel, and a handsome instrument board. McLaughlin-Buick four-wheel brakes and specially designed rear cantilever springs are features of this as of the other models. In beauty, riding comfort, and economy in operation, this model, like others in the McLaughlin-Buick line, cannot be surpassed.

McLAUGHLIN-BUICK TRANSMISSION

THE McLaughlin-Buick transmission is the selective sliding gear type, with three speeds forward and one reverse. It has been strengthened throughout in conformity with the increased engine power. All the gears have been increased in width, and are extremely tough with extra hard wearing surfaces. The transmission control lever has been lengthened for the convenience of the driver. The McLaughlin-Buick transmission is built as an integral part of the engine, eliminating the need for universal

joints which would be required if the transmission were separate from the engine.

The gear shift lever is conveniently placed and gears shift quietly and easily. In fact, shifting gears on a McLaughlin-Buick is so easy that it may be done with the tips of the fingers on the gear shift lever. Combined with the easy working McLaughlin-Buick clutch and the McLaughlin-Buick steering mechanism, the easy gear shift does much to explain McLaughlin-Buick's popularity, especially with women. Points like this demonstrate how carefully McLaughlin-Buick has considered every point of comfort and convenience for the driver as well as for the passengers.

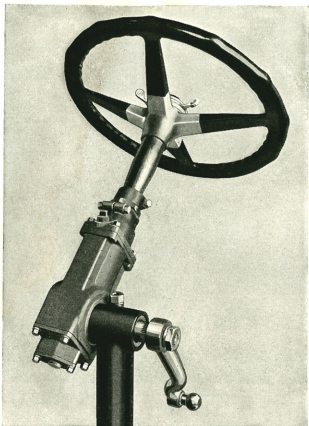

The McLaughlin-Buick steering gear of the worm and split nut, semi-irreversible type. A large bearing surface is provided by the five points of contact between the worm and the grooves on the nuts, reducing wear to a minimum and providing an added factor of safety. It is the ball bearing type which adds to the ease of operation. Road shocks are absorbed and do not reach the steering wheel.

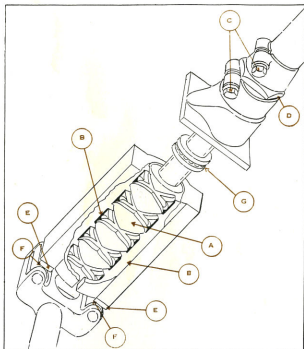

Diagram showing the construction of the McLaughlin-Buick steering gear. The worm (A) works in the groove on the split nuts (B). It operates in a bath of lubricant inside the steering gear housing. Adjustment is simply made by loosening the pinch bolts (C) and turning down the adjusting nut (D). The steel ends (E) of the split nuts operate on the rollers (F) on the rocker shaft, to which is attached the steering arm and rods, thus moving the wheels in the desired direction. Thrust is taken by the ball bearing (G).

THE McLAUGHLIN-BUICK STEERING GEAR

THE McLaughlin-Buick steering gear is of the worm and split nut, semi-irreversible type, fitted with a ball bearing. It is the most expensive and highly developed type known today.

McLaughlin-Buick believes in building this unit of the car with a generous reserve of strength, rather than using a less expensive and consequently weaker type.

In the McLaughlin-Buick steering gear there are five bearing surfaces between the worm and the grooves in the split nuts, distributing the wear over a large area and reducing it practically to nothing. Any slight wear that does develop is easily taken up by merely lifting the hood and giving the adjusting nut on the steering column a slight turn.

Why the McLaughlin-Buick steers easily

This ball bearing steering gear, together with the ball bearings in the steering knuckles on the front

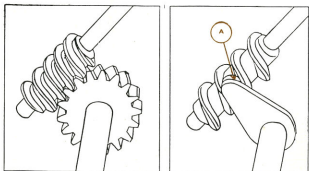
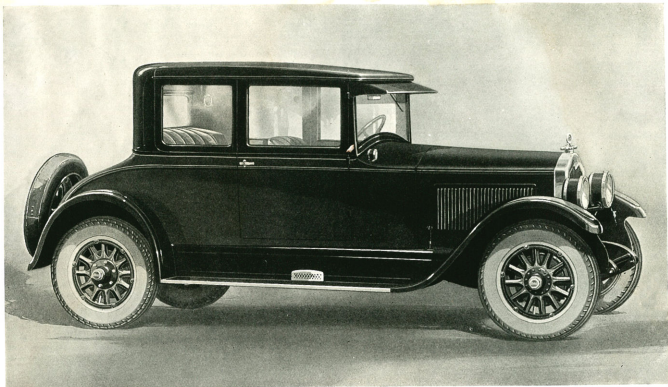

Diagram at left illustrates another type of steering gear, which is less expensive than the McLaughlin-Buick. In this type the bearing surface of the worm and gear is limited to not more than two teeth. To make adjustments the gear is turned, bringing new teeth into play. By reason of the small amount of bearing surface it is subject to greater wear.

Diagram at right illustrates still another type of steering gear of less expensive construction. The bearing surface is reduced to one point (A), with consequent increase in strain and wear.



McLaughlin-Buick four-passenger Coupe
Master Six . Model 48



Without any question this large, roomy four-passenger Coupe sets a new mark in Coupe development. The long, low body, ending in the graceful lines of the rear deck, together with the Duco finish in a most pleasing color, mark it most distinctively. Four large side windows and a large rear window afford a remarkable degree of vision. The car has a low and rakish appearance as well as an air of smartness, which is enhanced by the heavy artillery wheels and large size, low-pressure tires. The interior is luxuriously trimmed with rich plush of the finest quality, with high grade carpeting in harmony. Other features are: combination vanity and smoking case, heater, foot rests, an assist cord to help passengers in arising from the rear seat, and a large luggage compartment.

axle, the pivotal balance of the front wheels, and the caster angle of the front axle, accounts for the extremely easy manner in which the McLaughlin-Buick steers and holds the road at all speeds.

Comparison of the McLaughlin-Buick steering gear with less expensive types that could have been adopted by McLaughlin-Buick will quickly impress you with the value of McLaughlin-Buick's standard practice of providing the utmost in efficiency, economy, and convenience, together with a large factor of safety.

The steering gear is another example of the ex-

cess value that you will find in every part of the McLaughlin-Buick car.

THE STEERING WHEEL

THE McLaughlin-Buick steering wheels are handsome in appearance and of large size, adding to the easy steering of the car. Mounted in the center will be found short spark and throttle levers, together with a switch that regulates the headlight beams. Special Six models, 17½-inch wheel. Master Six models, 18-inch wheel.

The steering column is set at a convenient angle so that driver may enjoy the full comfort of the seat.



The cord to assist passengers in rising from the rear seats in Models 48, 50 and 51.

THE McLAUGHLIN-BUICK FRONT AXLE

THE McLaughlin-Buick front axle is a specially designed, drop-forged, I-beam type, providing an extra margin of strength above that required to stand the stress and strains of front-wheel brakes.

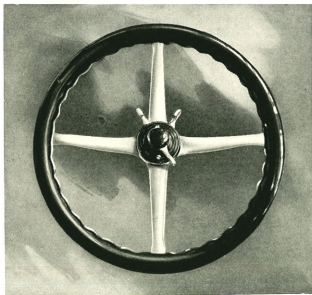

The McLaughlin-Buick steering wheel.

The spring seats are forged integral with the axle. There are no riveted or brazed parts, eliminating the possibility of breaking due to crystallization at the brazed points.

When the McLaughlin-Buick front axle is mounted it is tipped back at what is known as a caster angle. This contributes very greatly to the ability of the car to hold the road at all speeds. Were it not for this tilting of the axle, the car would be harder to drive, especially at high speeds.

Mounting the front axle at an angle throws a heavy strain on the spring seats. When these are riveted or brazed to the axle they do not provide the same margin of safety as when they are integral parts of the front axle, as in the McLaughlin-Buick.

This is another example of the extra margin of safety found throughout the McLaughlin-Buick, making it the greatest automobile value on the market.

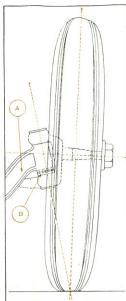

Pivotal balance, which has much to do with the easy steering of the McLaughlin-Buick, is here illustrated. The wheel and the axle are so constructed that the weight of the car is at the center of the tire, as shown by the lines drawn through the king pin and the tire, meeting at the ground. McLaughlin-Buick's five bearing surface steering gear, with axle set at a caster angle, and the pivotal balance of the front wheels, accounts for the easy manner in which the McLaughlin-Buick steers. Axle (A). Ball bearing (B).

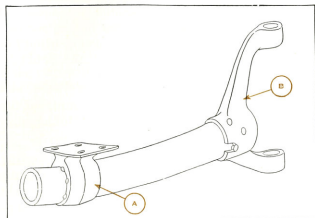

In this type of front axle the spring seats (A) and the yoke ends (B) are brazed and riveted on, making a less dependable axle than that used by McLaughlin-Buick, which is drop-forged in one piece, with no riveted or brazed parts.

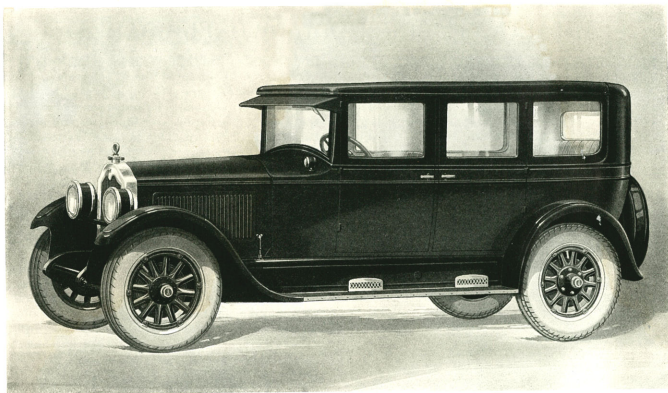

McLaughlin-Buick seven-passenger Sedan
Master Six . Model 50



This big seven-passenger Sedan has many refinements that give it a very striking appearance, and make it the last word in comfort and convenience. Double body moldings and striping and Duco finish in a very attractive color make it stand out as a car among cars. The auxiliary seats are exceptionally wide and deeply upholstered, with wide back rests. They will seat three if necessary. Extra leg room is provided by under-cutting the back of the front seat. The car is upholstered in the highest grade plush. Among its features are a smoking case, and a vanity case for ladies. The body is mounted on a 128-inch wheelbase chassis, powered by a 75 h.p. triple-sealed McLaughlin-Buick Valve-in-Head engine. It is an ideal car for those who want the very best.

McLAUGHLIN-BUICK WHEELS

THE wheels used on McLaughlin-Buick cars are of the heavy, wood artillery type. The hubs are extra large with heavy spokes of great strength, specially designed to provide a margin of safety above the strains of ordinary driving, coupled with those due to braking.

The rims and wheel felloes have been so constructed that the rim will not assemble on the wheel other than in its correct position. The rim is also provided with bosses so that the rim must center

accurately on the wheel, providing a true wheel balance. Improved wedges provide a solid support for the rim on the felloe.

The front wheels have a pivotal balance, of course, in order to add to the easy steering of the car.

There is no more substantial wheel construction than that used by McLaughlin-Buick.

In addition they have been carefully designed and decorated so that they harmonize with the color scheme of each particular model and add greatly to the smart appearance of the cars.

McLAUGHLIN-BUICK FOUR-WHEEL BRAKES

McLAUGHLIN-BUICK mechanically operated four-wheel brakes have proved their worth in the service of thousands of McLaughlin-Buick owners. They are of the external contracting type. The brake bands operate on brake drums with large bearing surfaces. The drums are securely bolted to the wheels.

The braking system is designed to exert, automatically, slightly greater pressure on the rear brakes. In turning a corner the brake on the outside

front wheel automatically releases, permitting the wheel to run free and giving perfect steering control when turning corners with the brakes applied.

Tires and brake bands both last longer because the wear is distributed over four tires and brake bands instead of two. The increased friction between the tires and the road provided by four-wheel brakes makes it possible to stop a McLaughlin-Buick very quickly, and provides the driver with an extra factor of safety.

The emergency, or hand brake

The emergency or hand brake on the McLaughlin-Buick is of the internal expanding type, operating on the inside of the brake drums of the rear wheels. It is entirely independent of the four-wheel service brakes and is used principally when parking the car.

THE McLAUGHLIN-BUICK HEADLIGHTS

THE new headlights on the McLaughlin-Buick are of the very latest type with controllable light beams. Without question this is one of the most outstanding improvements in motoring to date.

The beams of light are controlled by a switch mounted in the center of the steering wheel. For country driving the beams go directly out in front of the car, lighting the road for a great distance ahead and for its entire width. By simply shifting the lever the beams are deflected down directly in front of the car. As they are still of the same strength there is a large flood of light that makes driving in traffic, or when other cars are met, much safer, and provides great mental comfort to the driver.

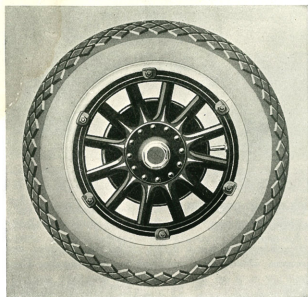

The McLaughlin-Buick wood artillery wheel, with large hub, short, heavy spokes, and large, low pressure tires. These wheels add materially to the appearance of the cars and provide an extra margin of safety. Tires on Special Six models are 31 by 5.25 and on Master Six models 33 by 6.

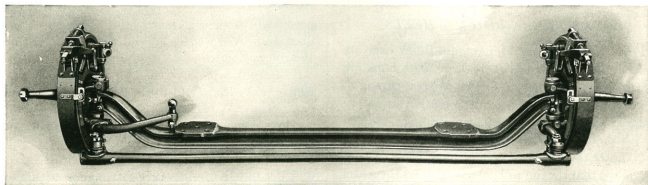

The brake drums and bands on the McLaughlin-Buick furnish a braking area sufficient to stop the wheels quickly and smoothly. The front axle is drop-forged in one piece. There are no brazed or riveted parts, therefore the axle possesses maximum strength.

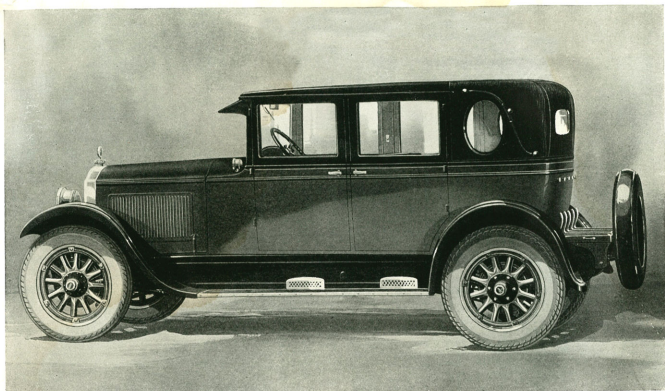

McLaughlin-Buick five-passenger Brougham Sedan
Master Six . Model 51



Here is a Brougham Sedan body on a 128-inch wheelbase chassis. It is most attractive in its appearance and in the luxury of its appointments. The body is finished in Duotone Duco colors, with wheels to match. The rear upper part of the body is covered with bright finish, long-grain leather. The interior is most pleasingly upholstered in rich mohair plush. The hardware is specially designed and the appointments are complete, including a smoking case in the back of the front seat. The smooth-running, snappy, 75 h.p. triple-sealed McLaughlin-Buick Valve-in-Head engine adds much to the pleasure of driving, and the knowledge that you have at all times at your command McLaughlin-Buick four-wheel brakes, provides motoring pleasure that can be approximated only in another McLaughlin-Buick model.

Lamps, bulbs and other parts are stationary. The change in the direction of the light rays is made entirely by shifting the current from one filament to the other in the bulb, aided by a specially designed lens built into the lamps.

The lamps are fitted with doors that are hinged at the top and fastened at the bottom with a screw for convenience in installing new bulbs when necessary.

The lamps are mounted on a cross bar extending from fender to fender, instead of being mounted direct to the fender with a stay rod in between.

This type of mounting eliminates the necessity for having right and left hand lamps. It makes adjustment much simpler, and in case of fender damage the lamps are not so apt to be distorted.

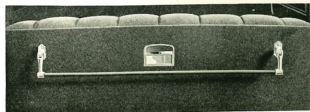

Smoking Case in back of Front Seat, Model 51.

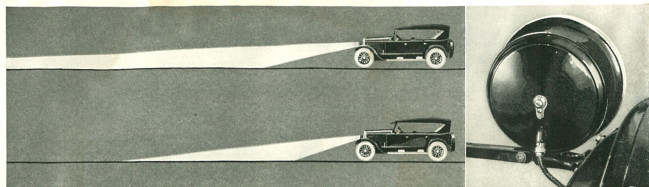

This illustration indicates the manner in which the light rays are raised or lowered by the simple operation of the switch lever in the center of the steering wheel. The McLaughlin-Buick headlights are simply

adjusted by the screw located on the rear of the lamp. The illustration also shows the manner in which the lights are mounted, eliminating the necessity for right and left hand lamps.

THE VENTILATING WINDSHIELD

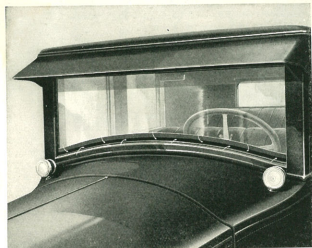

The Fisher V V windshield on all McLaughlin-Buick closed models is raised by a handle inside the car to admit air through the ventilator or, when raised higher, in a direct current. Arrows indicate circulation of air.

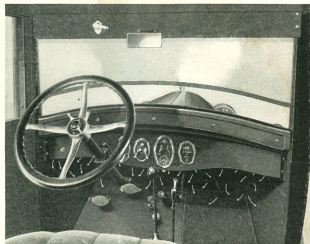

When the windshield is raised slightly it opens a vent the entire width of the car. Air is deflected through this vent down into the front compartment across the whole width.



Two extra passengers may be carried in the rear compartment seat on Model 54C

JACK LUG ON REAR AXLE

For convenience in raising the rear wheels from the ground when changing tires, the rear axle is provided with a lug extending out to the rear. This makes a convenient and easily accessible point of purchase for the jack, and will be readily appreciated by motorists. This is one of the many features of convenience on the McLaughlin-Buick.

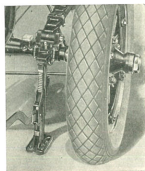

This photograph shows a jack in use under the lug.

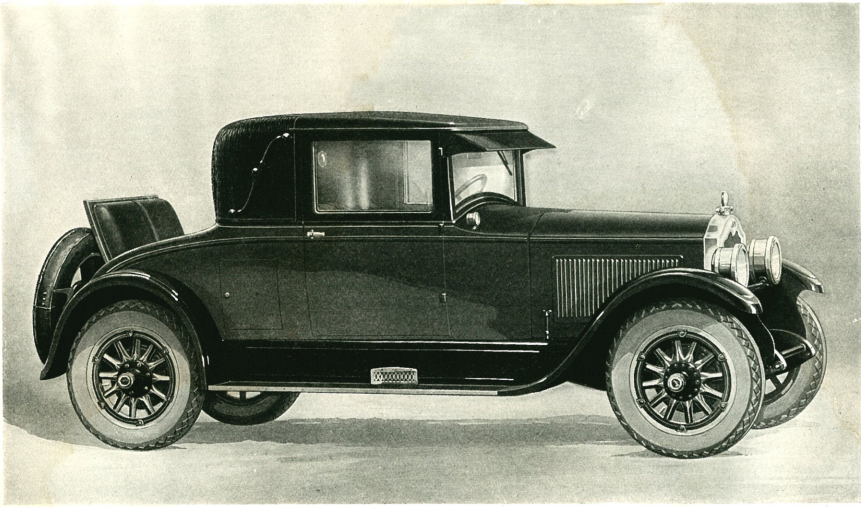

McLaughlin-Buick Country Club Coupe
Master Six . Model 54C



Here is the popular McLaughlin-Buick Country Club Coupe, a body type specially designed for those who desire comfort and luxury in a car of smaller passenger carrying capacity than the Sedan models. It is of the same general type as its companion model—the Brougham Sedan. The rear deck is large and has a Dickey seat for two extra passengers. The large rear window may be lowered, permitting those in the rear seat to converse with those in front. The body is finished in Duotone Duco colors, beautifully striped. There is an extra carrying compartment, reached by a door in the side of the body, fitted with a Yale lock. This model leaves nothing to be asked for by the most discriminating purchaser, and is especially liked by those who desire a smart looking second or third car.

CANTILEVER REAR SPRINGS

THE rear springs on McLaughlin-Buick cars are of the cantilever type. They are so designed that there is a long, flexible front section to absorb shocks on ordinary roads, and a short, stiff rear section, which absorbs the greater shocks on rough roads.

This short rear section, extending from the axle to the frame, reduces sidesway to a degree which is absolutely impossible with any other type of spring. The illustrations will make clear why this is so.

The cantilever rear springs on all McLaughlin-

Buicks are especially designed with regard to the weight and type of the particular body that they support. Together with low pressure tires, and very flexible seat cushions, they provide the riding comfort for which McLaughlin-Buick is particularly noted.

THE UNIVERSAL JOINT

THERE is no particular virtue attached to universal joints, and they are only used in automobile construction when absolutely necessary. The McLaughlin-Buick drive, being of the torque tube type, requires only one universal joint.

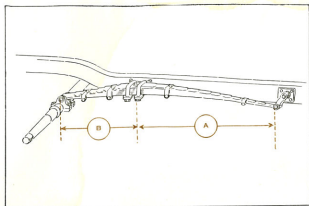

The long section (A) of the McLaughlin-Buick cantilever rear springs absorbs ordinary shocks. The short, heavy rear section (B) absorbs the greater shocks. As the frame and body are supported by the short section (B), from the axle to the spring bracket on the frame, the possibility of the body swaying in turning corners is reduced to a minimum.

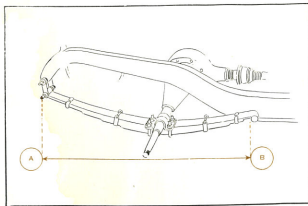

This illustration shows a semi-elliptic type rear spring. It is used in connection with the Hotchkiss drive. By reason of the frame and body being supported by the entire length of the spring from (A) to (B) the body is not held rigid when turning corners. The result is that there is greater sideways than with the McLaughlin-Buick cantilever rear springs.

If a Hotchkiss drive were used, and the McLaughlin-Buick transmission were not built integral with the engine, four, or at least three, universal joints would be absolutely necessary—two between the transmission and rear axle, because the drive shaft and rear axle are continually out of alignment, and one or two between the transmission and the engine to take care of strains and stresses transmitted to the engine and transmission from the frame.

These universal joints would have to be lubricated frequently or they would wear quickly and become noisy, and they would be very difficult to lubricate owing to their inaccessible position.

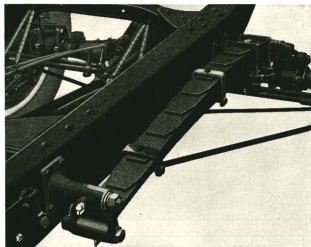

The McLaughlin-Buick cantilever rear springs.

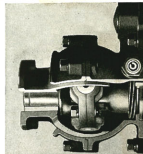
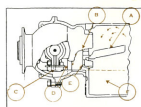

The McLaughlin-Buick universal joint is automatically lubricated by lubricant thrown from the transmission gears into the trough (A), then running through the hole (B) into the universal joint ball housing, and into the reservoir (C), thus providing the universal joint with a constant bath of lubricant. When the lubricant reaches the level (D) it passes through the opening (E) back into the transmission case (F). It is never necessary to pay any attention to the universal joint on a McLaughlin-Buick so far as lubrication is concerned.

If McLaughlin-Buick used this type of construction, these universal joints would be the only means of preventing the drive shaft from being broken, and of preventing excessive strains on the bearings.

The one universal joint on the McLaughlin-Buick connects the torque tube with the transmission and absorbs all driving strains. It is completely enclosed, dustproof, and automatically lubricated from the transmission. At no time is it necessary to put any lubricant in this joint. So far as any attention from the driver is concerned, he can forget that there is any such thing as a universal joint on his McLaughlin-Buick.

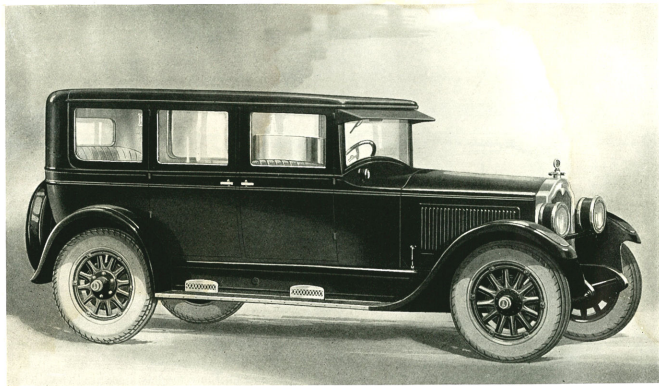

McLaughlin-Buick seven-passenger Limousine
Master Six, Model 50L



This handsome Limousine Body by Fisher mounted on the 128-inch wheelbase sealed chassis with 75 h.p. triple-sealed Valve-in-Head engine is the outstanding value in automobiles of the luxurious type. The double body molding and striping, and the attractive Duco color give it a very striking appearance. The auxiliary seats are exceptionally wide and deeply upholstered, with wide back rests. Upholstery is of high grade plush, all cushions deeply padded. The plate glass partition that encloses the driving compartment can be quickly lowered into the back of the front seat. The equipment includes automatic wind-shield wiper, rear-vision mirror, motometer, a smoking case, and a vanity case for ladies. This car is indicative of the scrupulous care of the master craftsmen, and is the last word in comfort and convenience.

LESS DIRT—LONGER LIFE

Over a year ago McLaughlin-Buick engineers evolved a sealed chassis—one which is virtually dirt proof. This was done by enclosing practically every moving part so that dirt or water could not find its way in. Now McLaughlin-Buick engineers have won another victory over dirt, the greatest enemy of automobile machinery. They have blocked the only three remaining means by which dirt might enter the engine, namely the gasoline, air and oil channels—by means of the gasoline strainer, the air cleaner and the oil filter described in detail elsewhere in this book.

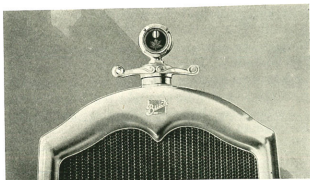

Special radiator cap with motometer on Models 48, 49, 50, 50L, 51, 54C.

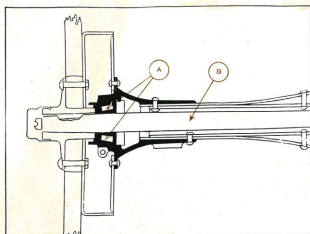

is the semi-floating axle. In this type the bearing (A) is mounted directly on the axle shaft (B) with the result that the shaft must carry the weight of the car in addition to turning the wheel. If the shaft breaks the wheel comes off.

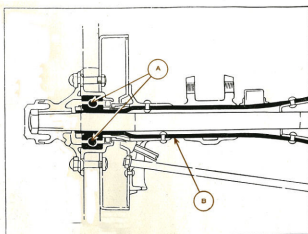

The McLaughlin-Buick floating rear axle. In this type the bearing (A) is mounted on the rear housing (B). The weight of the car is on the housing, not on the shaft. If the shaft break the wheel does not come off, and the car may be towed.

FLOATING TYPE REAR AXLES

THE rear axles on McLaughlin-Buick cars are of the floating type. This means that the wheels are mounted on ball bearings which fit over the rear axle housing. None of the weight of the car is borne by the axle shaft. The only duty that the rear axle shaft is called upon to perform is to turn the wheels.

This provides an extra margin of safety and re-

duces the possibility of broken axle shafts to the very minimum.

The axles on these models, including the differential case and gears, which are carried in the center housing, have been made especially strong to take care of the extra power furnished by the engine. In other words, the same extra margin of safety that has been built into the balance of the car has been maintained at this point.

THE McLAUGHLIN-BUICK TORQUE TUBE DRIVE

AN automobile is driven by the power from the engine transmitted to the rear wheels. The wheels in turning push the car forward. This pushing force generally is transmitted to the frame of the car through the rear springs, a system known as the Hotchkiss drive. This system places the rear springs under a double strain. They not only must absorb road shocks but must also take the driving strain.

Furthermore, because the springs are flexible, they cannot hold the rear axle rigidly in position. Whenever one of the springs is deflected by a bump in the road the rear axle is thrown out of alignment, and the car loses part of the direct pushing force that sends it forward.

The propeller shaft is also thrown out of alignment, and this is such a serious drawback that two universal joints, one at each end of the propeller shaft, are used to counteract it as much as possible. Both of these universal joints require frequent lubrication and, as they are very difficult to reach, this causes the owner considerable trouble.

If one of the springs happens to break under the double strain to which it is subjected the car cannot be driven until the spring is repaired.

The McLaughlin-Buick torque tube drive has none of these disadvantages. The drive is taken by the sturdy torque tube that encloses the propeller shaft.

The rear springs are relieved of all driving strain.

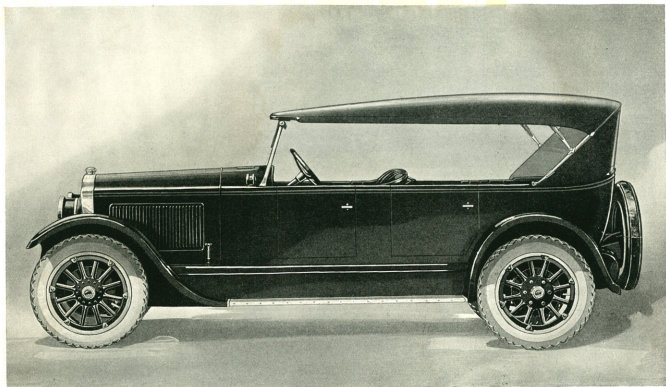

McLaughlin-Buick seven-passenger Touring
Master Six . Model 49



This large seven-passenger touring has the grace of line that gives it a very striking appearance, and the richness of interior and exterior finish make it distinctive in any group of automobiles. The body is finished in attractive Duco colors, with wheels finished to match. The top has natural wood bows with nickelled slat irons, and is covered with heavy top material. The curtains are close fitting. The auxiliary seats are exceptionally wide with wide back rests and will accommodate three passengers with comfort. The upholstery is high grade genuine leather, all cushions deeply padded. The body is mounted on the 128-inch wheelbase chassis and has the famous McLaughlin-Buick 75 h.p. triple-sealed Valve-in-Head engine. Automatic wind-shield wiper, rear vision mirror, motometer, and tool pocket in right front door are all standard equipment. There is a more complete measure of satisfaction in this model that cannot be appreciated except through experience.

Rigid strut rods hold the torque tube and the rear axle in perfect alignment, making them one unit. In this type of construction it is absolutely impossible for the rear axle to get out of alignment with the driving shaft, which is enclosed in the torque tube, and therefore only one universal joint is needed.

This one universal joint is automatically lubricated by oil coming from the transmission into the ball housing, inside of which the universal joint operates, then overflowing back into the transmission. The universal joint thus runs in a constant

bath of oil, and requires no other attention whatever, as far as lubrication is concerned.

The McLaughlin-Buick is not driven through rear springs.

If both rear springs on a McLaughlin-Buick were removed the car could still be driven.

The torque tube construction on the McLaughlin-Buick is more expensive to manufacture, but it eliminates trouble and expense for the owner. McLaughlin-Buick at no time builds a car to meet a price.

It builds a car according to the best type of con-

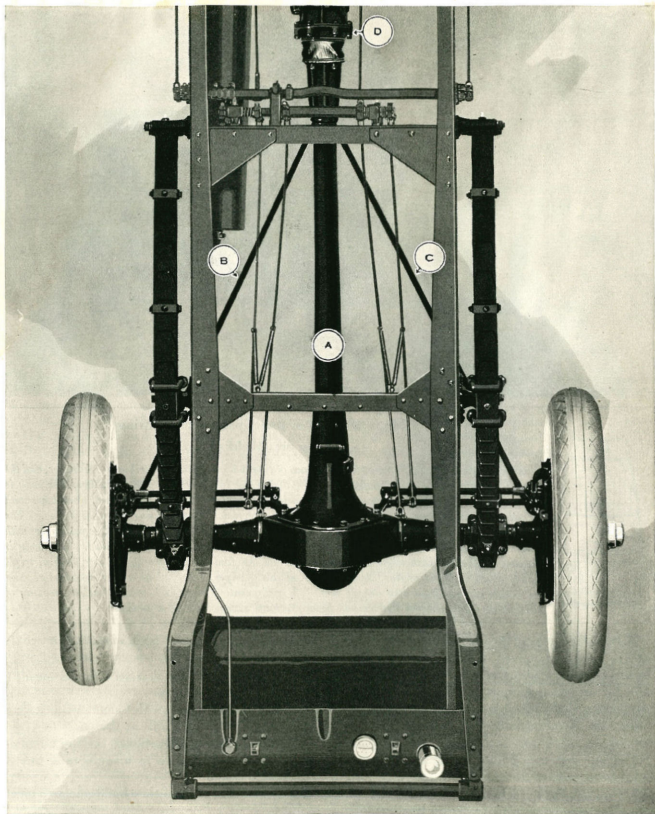

The McLaughlin-Buick torque tube drive

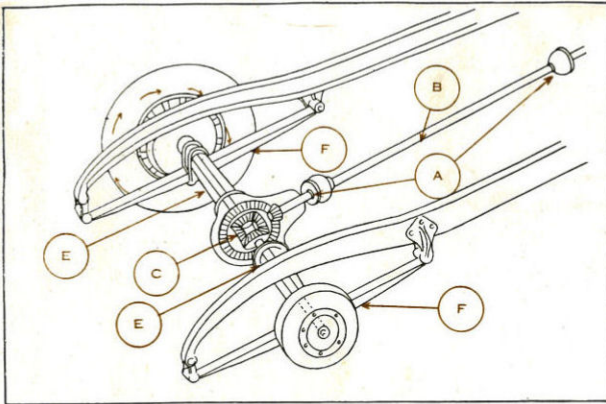

The Hotchkiss drive type of axle commonly used is fitted with two universal joints (A) because the axle is not held rigid and these joints are necessary to relieve the drive shaft and bearings from strain as the axle is thrown out of alignment with the driving shaft when the springs are deflated unevenly in going over rough or bumpy roads.

These joints are not automatically lubricated, and if neglected they become noisy.

The propeller shaft (B), which is not enclosed, transmits the power of the engine to the rear wheels through the differential (C) and axle shafts (E, E).

This long shaft with a heavy universal joint at each end, and not supported by bearings, whips out of line causing an uneven running car.

The arrows indicate the direction of the driving force which has a tendency to turn the axle around. In this type of drive the springs (F) have to hold the axle in place. They have to take all the driving strain, and also absorb the shocks from the road. If one of the springs should break the car could not be driven because the axle would be too far out of alignment.

This type of construction makes the car hard to handle when the going is rough and makes it more difficult to pull out of sand and mud. It is a much cheaper type of axle than the torque tube type used by McLaughlin-Buick.

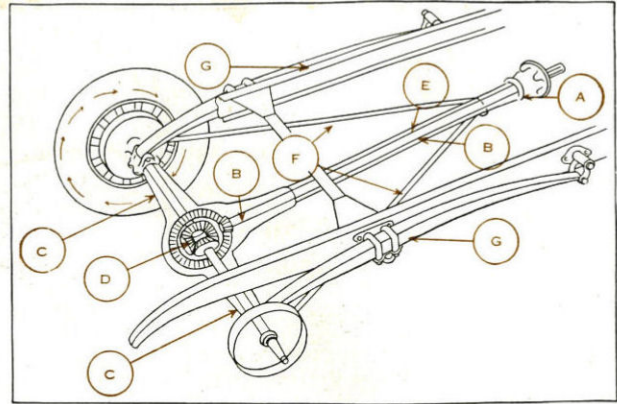

In the McLaughlin-Buick torque tube drive only one universal joint (A) is needed. This joint is automatically lubricated from the transmission, therefore you never have to bother with it.

The drive shaft (B), which is entirely enclosed, transmits the power from the engine to the axle shafts (C, C) through the differential (D). This shaft (B) is supported by bearings at both ends and, without heavy unsupported universal joints, runs practically true, lending to the smooth operation of the car.

The arrows show the direction in which the wheels are forced around. This driving force has a tendency to turn the rear axle around, but the torque tube (E), being rigidly bolted to the rear axle housing and attached to the transmission case by the ball housing, enclosing the universal joint, holds the axle in place, and takes all the driving and torque strains.

The strut rods (F) keep the third member and rear axle in perfect alignment.

The springs (G) are relieved of all driving strains. They have no other duty but to make the car ride easy. If one or both springs should break the car may still be driven home.

This type of construction makes the McLaughlin-Buick easy to handle when the going is rough, and also accounts for the ability of a McLaughlin-Buick to pull out of bad places.

struction that is known and, by reason of its great volume of sales, it is possible for McLaughlin-Buick to build this type of car to sell at a price that would be absolutely impossible if only a few thousand cars were made a year.

McLaughlin-Buick's position as a leader in the industry makes it possible to give greater value instead of using a cheaper type of construction in

order to build a car in a certain price classification. Not how cheaply, but how well 'can we build, is McLaughlin-Buick's motto.

Modern machinery, complete facilities for economical manufacturing, and large production, with their consequent reduction in overhead expense, enable McLaughlin-Buick to give the greatest dollar for dollar value in an automobile.

On the opposite page is shown an illustration of the McLaughlin-Buick torque tube drive

- A. The torque tube—in the McLaughlin-Buick the driving force from the rear wheels is taken by this sturdy tube that encloses the propeller shaft.
- B. and C. The strut rods—these hold the torque tube and the rear axle in perfect alignment so that the car gets the full benefit of the driving force from the rear wheels all the time.
- D. The universal joint ball housing—the driving force is applied to the car at this point by the rigid torque tube.

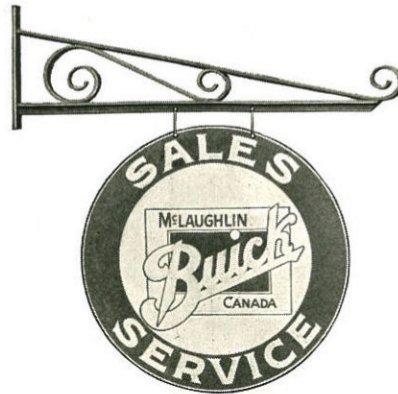

NATION-WIDE SERVICE

McLaughlin-Buick has not felt content with only building long life and satisfactory service into its product. It does not believe that its obligation ceases when the car is sold.

Ever since the McLaughlin-Buick automobile was introduced to the Canadian public, it has been the policy of the Company to so situate the Branches and Service Stations that car owners may, at all times, receive as nearly 100% service as is possible.

The motto of McLaughlin-Buick is that an owner is entitled to efficient service, courteously rendered, at a fair price. This motto is responsible for the establishing of Dealers and authorized service stations in practically every city and town in the Dominion.

Replacement Parts

The McLaughlin-Buick sign is prominently displayed on the premises of dealers and service stations and is your assurance that Genuine McLaughlin-

Buick Parts are used in servicing McLaughlin-Buick automobiles.

Maintenance

Flat rate charges for labor which have been worked out by the Company as a protection to car owners, is in operation at all Branches and is rapidly being adopted by our dealers. This insures a standard charge for maintenance work throughout the country.

Branch Organization

Besides the hundreds of McLaughlin-Buick Dealers and Authorized Service Stations throughout the country, there is a chain of direct factory Branches located at strategic points for the distribution of McLaughlin-Buick cars and parts.

When touring in the United States McLaughlin-Buick owners are assured of efficient and courteous attention at the hands of McLaughlin-Buick Dealers. Servicing facilities are also available in many foreign countries.

STANDARD EQUIPMENT

SPECIAL SIXES

- Model 20—Five-passenger two-door Sedan
- 24—Four-passenger Roadster -
- 25—Five-passenger Touring - -
- 26—Two-passenger Coupe - -
- 27—Five-passenger Sedan - -
- 28—Four-passenger Coupe - -

MASTER SIXES

- Model 40—Five-passenger two-door Sedan
- 44—Two-passenger Roadster -
- 45—Five-passenger Touring - -
- 47—Five-passenger four-door Sedan
- 48—Four-passenger Coupe - -
- 49—Seven-passenger Touring - -
- 50—Seven-passenger Sedan - -
- 50L—Seven-passenger Limousine -
- 51—Five-passenger Brougham Sedan
- 54C—Country Club Coupe - -

WHEELBASE—All Special Six models 114 $\frac{3}{8}$ inches.
 Master Six, Models 40-44-45-47, 120 inches.
 Master Six, Models 48-49-50-50L-51-54C, 128 inches.

ENGINES—Special Six Models, 60 h.p. McLaughlin-Buick Valve-in-Head, triple-sealed. (N.A.C.C. rating 23.4). Bore 3 $\frac{1}{8}$ inches. Stroke 4 $\frac{1}{2}$ inches.
 Master Six Models, 75 h.p. McLaughlin-Buick Valve-in-Head, triple-sealed. (N.A.C.C. rating 29.4). Bore 3 $\frac{1}{2}$ inches. Stroke 4 $\frac{3}{4}$ inches.

ALL MODELS—Four-wheelbrakes; four low-pressure tires; new style, controllable beam headlights with control switch on top of steering wheel; air cleaner; oil filter; gasoline strainer; windshield wiper; sunshade on all closed models;

tire carrier for one tire only with extra demountable rim; jack; high pressure grease gun; tool kit; pump; tire repair kit; transmission lock; cowl or windshield ventilator; rear vision mirror.

Scuff plates on Models 24-48-50-50L-51-54C.

Door locks on all closed models.

Front snubbers, dash gasoline gauge on Models 48-49-50-50L-51-54C.

Heaters on Models 48-50-50L-51-54C. Connections for installing heater on all other closed models.

Automatic windshield wiper on all closed models and models 24 and 49. All other open models hand-operated wipers.

Window shades, rear on all closed models, and also rear side windows, Models 20-27-28-40-47-48. Rear window, rear side windows and rear doors, shades on Models 50-50L-51.

Combination vanity and smoking case on Model 48. Smoking case, and vanity case for ladies on Model 50-50L.

Smoking case on back of front seat on Model 51.

Assist cord on Models 48-50-51.

Spare tire not part of standard equipment. No allowances will be made for any part of standard equipment omitted by customer's order. Right reserved to make additions and any changes, without notice. All cars subject to Standard Warranty.

INDEX

SPECIAL SIXES

MODEL	PAGE	MODEL	PAGE
20—Five-passenger two-door Sedan	- - 9	26—Two-passenger Coupe	- - - 15
24—Four-passenger Roadster	- - - 11	27—Five-passenger Sedan	- - - 17
25—Five-passenger Touring	- - - 13	28—Four-passenger Coupe	- - - 19

MASTER SIXES

40—Five-passenger two-door Sedan	- - 21	50—Seven-passenger Sedan	- - - 33
44—Two-passenger Roadster	- - - 23	51—Five-passenger Brougham Sedan	- - 35
45—Five-passenger Touring	- - - 27	54C—Country Club Coupe	- - - 37
47—Five-passenger four-door Sedan	- - 29	50L—Seven-passenger Limousine	- - 39
48—Four-passenger Coupe	- - - 31	49—Seven-passenger Touring	- - - 41

- A -

Adjusting valves	- - - - - 13, 14
Air cleaner	- - - - - 7, 8
Authorized Service	- - - - - 44
Automatic heat control	- - - - - 22
Automatic lubrication	- - - - - 8, 9, 12
Axle, front	- - - - - 32, 34
Axle, rear	- - - - - 40

- B -

Balance	- - - - - 14, 15
Balance, pivotal	- - - - - 32
Bearings, engine	- - - - - 14, 15, 16
Brakes	- - - - - 34

- C -

Cantilever rear springs	- - - - - 37, 38
Carburetor	- - - - - 21, 22, 23
Carburetor heat control	- - - - - 22, 23
Chassis	- - - - - 24, 25
Chassis lubrication	- - - - - 11
Clutch	- - - - - 27, 28
Crankshaft	- - - - - 14, 16

- D -

Drive, torque tube	- - - 40, 41, 42, 43
--------------------	----------------------

- E -

Engine	- - - - - 4, 5, 7, 29
Engine bearings	- - - - - 14, 15, 16
Engine bore	- - - - - 45
Engine lubrication	- - - - - 8, 9, 12
Engine stroke	- - - - - 45
Engine suspension	- - - - - 7
Engine torque	- - - - - 7
Equipment, Standard	- - - - - 45

- F -

Fan	- - - - - 11, 12
Flat service rates	- - - - - 44
Floating type rear axle	- - - - - 40
Four-wheel brakes	- - - - - 34
Front axle	- - - - - 32, 34

- G -

Gasoline mileage	- - - - - 7
Gasoline strainer	- - - - - 8
Generator	- - - - - 21, 22
Grinding valves	- - - - - 13, 14

INDEX

- H -	PAGE	- S -	PAGE
Headlights - - - - -	34, 35, 36	Sealed chassis - - - - -	24, 25
Heat control - - - - -	22	Service - - - - -	44
Horsepower - - - - -	7, 45	Service rates - - - - -	44
- I -		Speed - - - - -	7
Insurance rates - - - - -	6	Springs, rear - - - - -	37, 38, 42, 43
- J -		Standard equipment - - - - -	45
Jack lug on rear axle - - - - -	36	Starter - - - - -	19, 20
- L -		Steering gear - - - - -	30, 31
Lubrication, chassis - - - - -	11	Steering wheel - - - - -	31
Lubrication, engine - - - - -	8, 9, 12	Suspension - - - - -	7
Lug, jack lug on rear axle - - - - -	36	- T -	
- M -		Tires - - - - -	45
Manual heat control - - - - -	22	Tops - - - - -	6
Mileage - - - - -	7	Torque, engine - - - - -	7
Motor—see engine		Torque tube drive - - - - -	40, 41, 42, 43
McLaughlin-Buick authorized service - - - - -	44	Training McLaughlin-Buick experts - - - - -	44
- N -		Transmission - - - - -	28, 29
N. A. C. C. ratings - - - - -	45	- U -	
- O -		Universal joint - - - - -	37, 38
Oil filter - - - - -	8, 9, 10	- V -	
Oil pump - - - - -	10, 12	Valves, adjusting - - - - -	13, 14
- P -		Valves, grinding - - - - -	13, 14
Parts - - - - -	44	Valve-in-Head engine - - - - -	4, 5, 7, 29
Pistons - - - - -	15, 16	Valve-in-Head principle - - - - -	17, 18
Pivotal balance - - - - -	32	Ventilating windshield - - - - -	36
Pump, oil - - - - -	10, 12	- W -	
Pump, water - - - - -	13, 14	Water-jacketing - - - - -	16, 17
- R -		Water pump - - - - -	13, 14
Radiator - - - - -	23, 26	Windshield - - - - -	36
Rear spring - - - - -	37, 38, 42, 43	Wheels - - - - -	33, 34
		Wheel, steering - - - - -	31, 32

