



The Terror of Audi | 2012

Note: A word about this brochure. Audi of America, Inc., believes the specifications in this brochure to be correct at the time of printing. However, specifications, standard equipment, options, fabrics, and colors are subject to change without notice. Some equipment may be unavailable when your vehicle is built. Please ask your dealer for advice concerning current availability of standard and optional equipment, and your dealer will verify that your vehicle will include the equipment you ordered. Vehicles in this brochure are shown with optional equipment. See your dealer for complete details on the New Vehicle Limited Warranty, twelve-year limited warranty against corrosion perforation, and Audi 24/7 Roadside Assistance. (Roadside assistance coverage provided by Road America in the U.S. Certain conditions apply; see your dealer for details.) Tires supplied by various manufacturers. "Audi," all model names, "ASF," "e-tron," "FrontTrak," "FSI," "MMI," "multitronic," "quattro," "S line," "S tronic," "TFSI," "Truth in Engineering" and the four rings logo are registered trademarks of AUDI AG. "TDI" is a registered trademark of Volkswagen AG. "Alcantara" is a registered trademark of Alcantara S.p.A. "Bang & Olufsen" is a registered trademark of Bang & Olufsen. The BLUETOOTH word mark and logos are owned by the Bluetooth Sig. Inc., and any use of such marks by AUDI AG is under license. "BOSE" and "AudioPilot" are registered trademarks of the Bose Corporation. "Fender" and "Stratocaster" are registered trademarks of Fender Musical Instruments Corporation. "Google" is a registered trademark of Google Inc. "HD Radio" and the HD Radio logo are proprietary trademarks of iBiquity Digital Corporation. "HomeLink" is a registered trademark of Johnson Controls Technology Company. "iPod" is a registered trademark of Apple, Inc. "SiriusXM" and all related marks and logos are trademarks of Sirius XM Radio Inc. and its subsidiaries. "Tiptronic" is a registered trademark of Dr. Ing. hc F. Porsche AG. All other trademarks are the property of their respective owners. Some European models shown.

Audi connect and Wi-Fi features require a data subscription plan. Distracted driving can cause a loss of vehicle control. Audi connect and Wi-Fi features and technologies discussed in this brochure are offered for convenience, and should be used only when it is safe and appropriate. The Wi-Fi hotspot feature is intended for passenger use only. Always pay careful attention to the road, and do not drive while distracted.

Audi MMI® Navigation plus depends on signals from the worldwide Global Positioning Satellite network. The vehicle's electrical system, and existing wireless and satellite technologies, must be available and operating properly for the system to function. The system is designed to provide you with suggested routes in locating addresses, destinations and other points of interest. Changes in street names, construction zones, traffic flow, points of interest and other road system changes are beyond the control of Audi of America, Inc. Complete detailed mapping of lanes, roads, streets, toll roads, highways, etc., is not possible, therefore you may encounter discrepancies between the mapping and your actual location. Please rely on your individual judgment in determining whether or not to follow a suggested Audi Navigation plus route. Periodically, the mapping is updated, and a new DVD will be required in order to maintain the latest navigation information available to us. These will be available for purchase from time to time at an additional cost. Consult your dealer or call 1-800-FOR-AUDI for details.

SiriusXM Satellite Radio and Traffic subscriptions sold separately or as a package after trial expires. SiriusXM Traffic service available in select markets. Subscriptions are governed by SiriusXM Customer Agreement (see www.siriusxm.com) and are continuous until you call SiriusXM to cancel. Sirius U.S. Satellite Service available only to those 18 and older in the 48 contiguous U.S.A., D.C. and Puerto Rico (with coverage limitations).

Summer performance tires are supplied and warranted by their manufacturer. High-performance tires are designed for optimum performance and handling in warm climates. They are not suitable for cold, snowy, or icy weather conditions. If you drive under those circumstances, you should equip your vehicle with all-season or winter tires, which offer better traction under those conditions. We suggest you use the recommended winter or all-season tire specified for your car or its equivalent. These high-performance tires also have a lower aspect ratio that aids performance and handling; however, in order to avoid tire, rim or vehicle damage, it is important that the inflation pressure is regularly checked and maintained at optimum levels. Please also remember in making your selection that, while these tires deliver responsive handling, they may ride less comfortably and make more noise than other choices. Finally, these tires may wear more quickly than other choices.

2012 | Brand

Audi of America
Audiusa.com
Facebook.com/Audi

AoA1211870

© 2011 Audi of America, Inc. Printed in U.S.A.



Truth starts at birth



Taine Rhône reds. Italian leather. Vermont cheddar. Like those, Audi is very much a product of where it came from. It's called *terroir*, and we've translated it to automobiles. It helps explain our take on luxury and why we challenge convention, actually. Figuring out how the climate, the soil and the topography create a singular truth, an intrinsic authenticity that can be found nowhere else, and how all these physical influences shape the progressive inspiration of our engineers, designers and thinkers.

We certainly have our own *terroir*. One shaped by the mountains, forests and extreme weather of Germany. Inspired by the autobahn, hairpin turns and early twilight. And, of course, by our home in Ingolstadt, along with the passions and personality of the people who live there. And like a fine wine, its heritage helps articulate how it came to be, to deepen the connection between the product and the person. As always, the real joy is in the discovery you feel experiencing it. It's the truth from which the Truth in Engineering® was born.

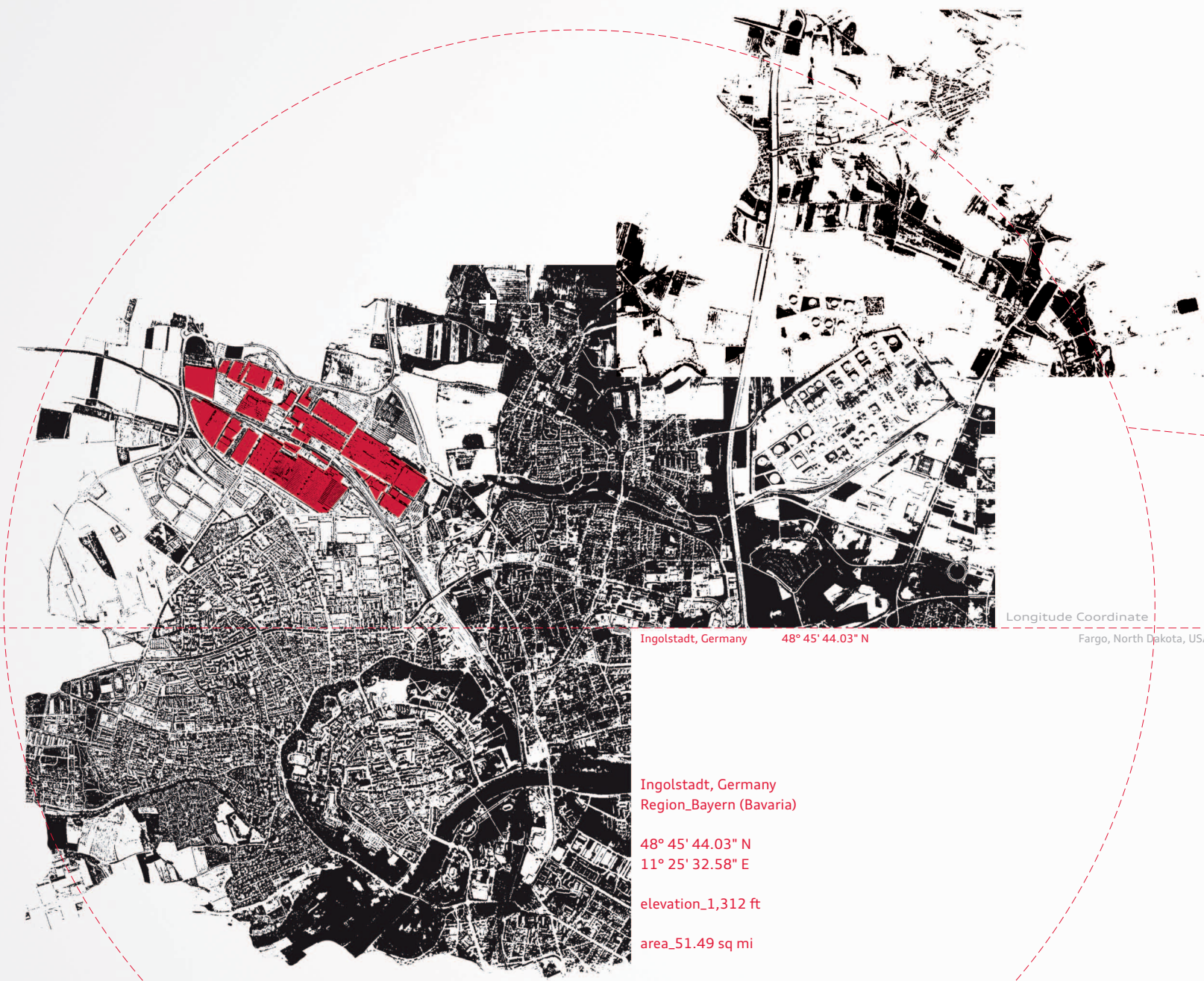

Ingolstadt, Germany 48° 45' 44.03" N

Longitude Coordinate
 Fargo, North Dakota, USA

Ulaanbaatar, Mongolia

Vladivostok, Siberia

Ingolstadt, Germany
 Region_Bayern (Bavaria)

48° 45' 44.03" N
 11° 25' 32.58" E

elevation_1,312 ft

area_51.49 sq mi

average low temp_24.8° F
 average high temp_71.6° F

average rainy days per month_15 days
 average snow days per year_58 days

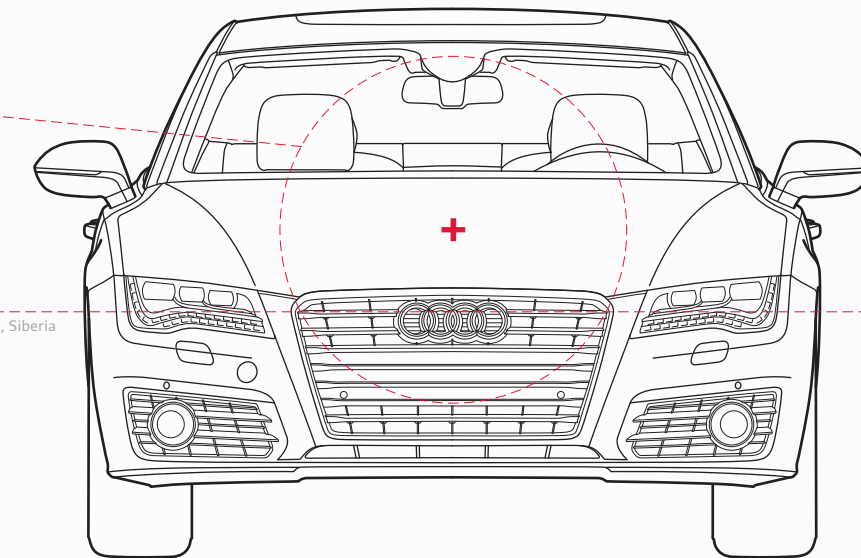

Provocation

We change the way people look at things. Germany has long been an epicenter of change. Of seeing the world differently. Of adapting to new standards. Of breaking new ground. This is an Audi cornerstone. By continually challenging the existing belief system, Audi provocation leads the way to new conventions.

Climate

The weather keeps Germans inside quite a bit. Where others might become stir-crazy, for us it becomes time to explore our thoughts. Audi engineers use this time to think about the elements outside, and how to overcome them through progressive thinking. We may think indoors, but our thoughts are far from insular.

Organization

Germans prefer to make order from chaos. We are precise and orderly because we think it's important to mean what you say, and to be clear in what you do. Audi reflects that through visionary engineering. It is deceptively simple—organization is having the right thing in the right place, for the right moment.

Landscape

Think of it this way—the Alps help you corner. The long, flat plains make you accelerate. The forest spurs driver-assistance technology. Who knew that the varied terrain of Germany would influence how you experience the road in the U.S.?

Psychology

What do you see in cars? Economy of form. Efficiency of thought that translates into precise actions. The psychology of Audi engineers is modern and uncluttered. It's not excess that interests us, but addressing desires in a way that makes people nod and say, Yes, that is Truth in Engineering.

Strength P. 2
 ASF® P. 4
 Material innovations P. 6
 Mass reduction P. 8

Audi quattro® P. 10
 Handling P. 12

Precise construction P. 14
 Sight P. 16
 Sound P. 18
 Interior P. 20

Performance P. 22
 Perception P. 24

Infotainment P. 26
 Electric P. 28
 Efficiency P. 30

The difference between strength and flexibility is perspective.

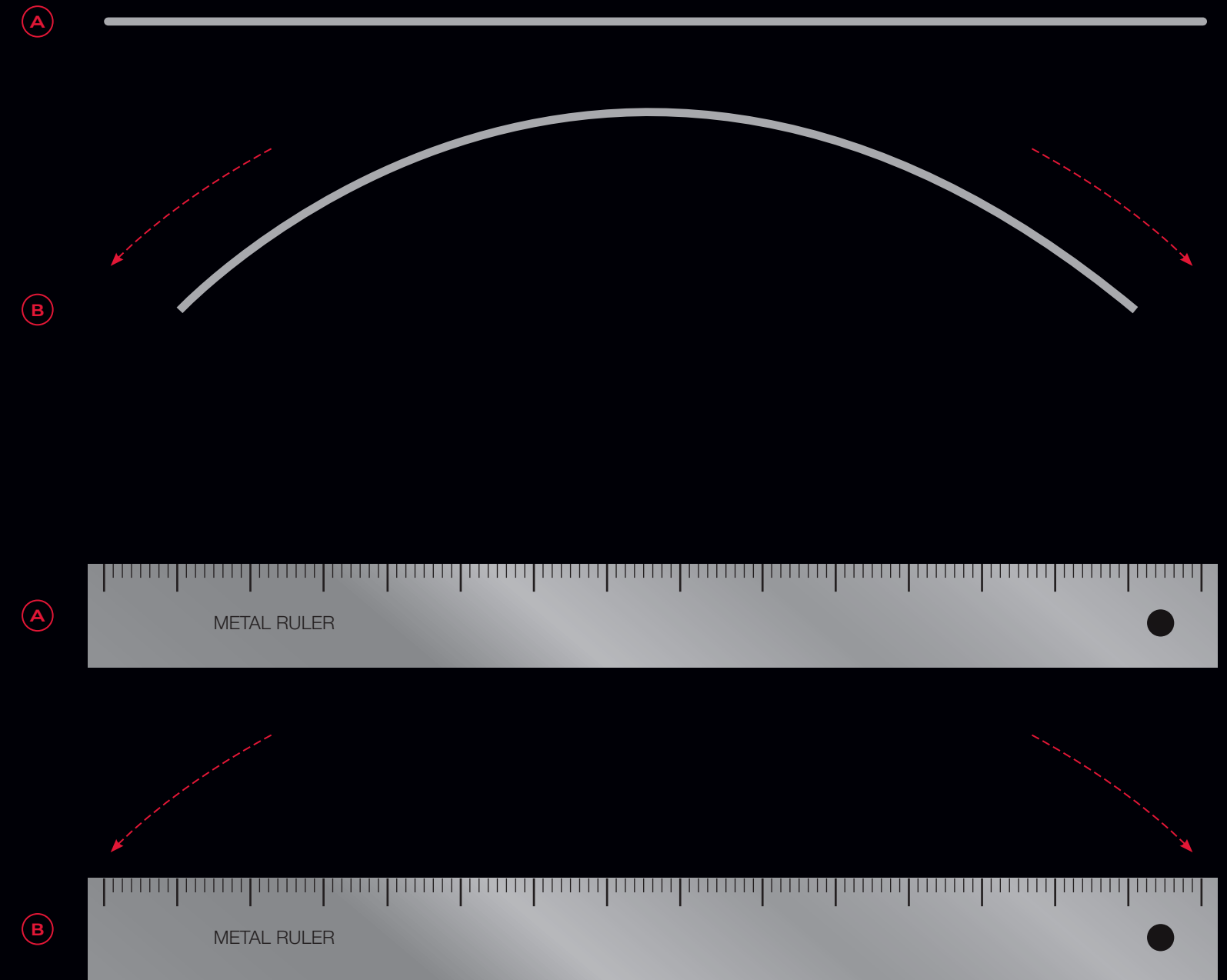

+ German Beer Purity Law
 In a clever way to assert brewing primacy while challenging everyone else to get into line, the city of Ingolstadt was the first to define what could go into beer—water, barley, and hops—and the first to pass the famous German Beer Purity Law in 1516.



Weight savings and uncompromised strength

If rigid thinking is the status quo, Audi is ultraflexible. For instance, where others assumed the need for steel, Audi saw how steel alone made a vehicle heavier, less efficient and harder to stop quickly. So with our “Audi ultra” initiative, we thought in terms of materials to help make our vehicles lighter, helping enhance fuel efficiency and improve braking response.¹ It’s a matter of perspective. Positioned one way, aluminum materials can be flexible. Positioned another, they are strong and rigid. Positioned in an Audi and working with steel and, soon, carbon-fiber elements, they are a provocation to everyone else: you’ve been thinking about strength in the wrong way. Lighten up.

¹ See www.fueleconomy.gov for EPA estimates. Your mileage will vary.

What happens when everyone is expected to carry the load.

ASF® In traditional luxury, the typical reaction is “more.” More is better, right? Not always. Audi built an entire Lightweight Design Center in Neckarsulm, Germany, where engineers worked together to create a radically different idea—that true luxury can be found in less. The group effort first paid off with our legendary ASF lightweight aluminum space frame technology. By placing the right material where it is most needed, we shed the sluggish excess of old luxury, and made our lightweight ASF technology part of a better performing, more efficient and entirely different luxury brand.¹

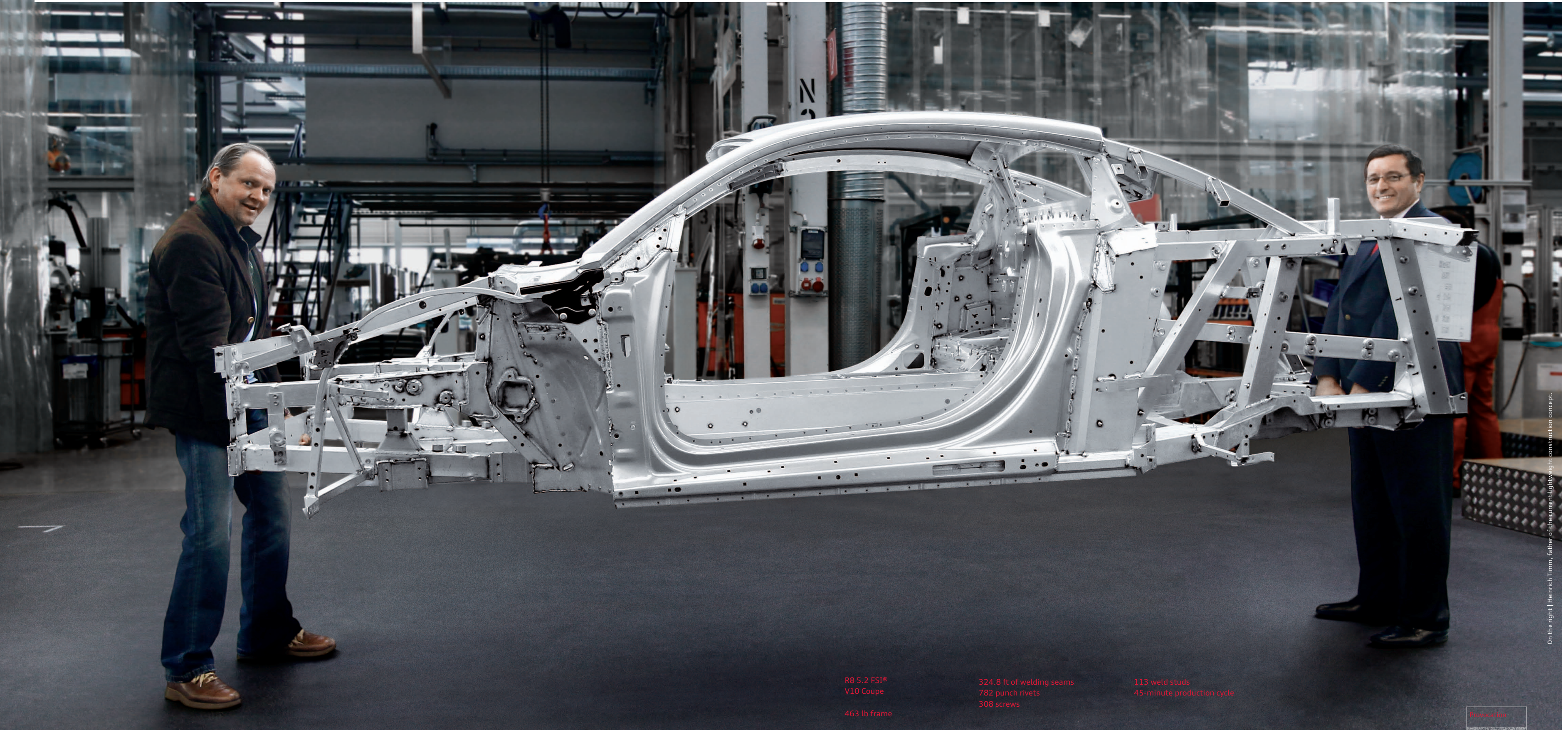

R8 5.2 FSI®
V10 Coupe
463 lb frame

324.8 ft of welding seams
782 punch rivets
308 screws

113 weld studs
45-minute production cycle

On the right | Heinrich Timm, father of the current lightweight construction concept.

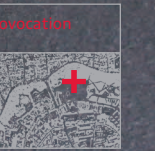

¹ See www.fueleconomy.gov for EPA estimates. Your mileage will vary.

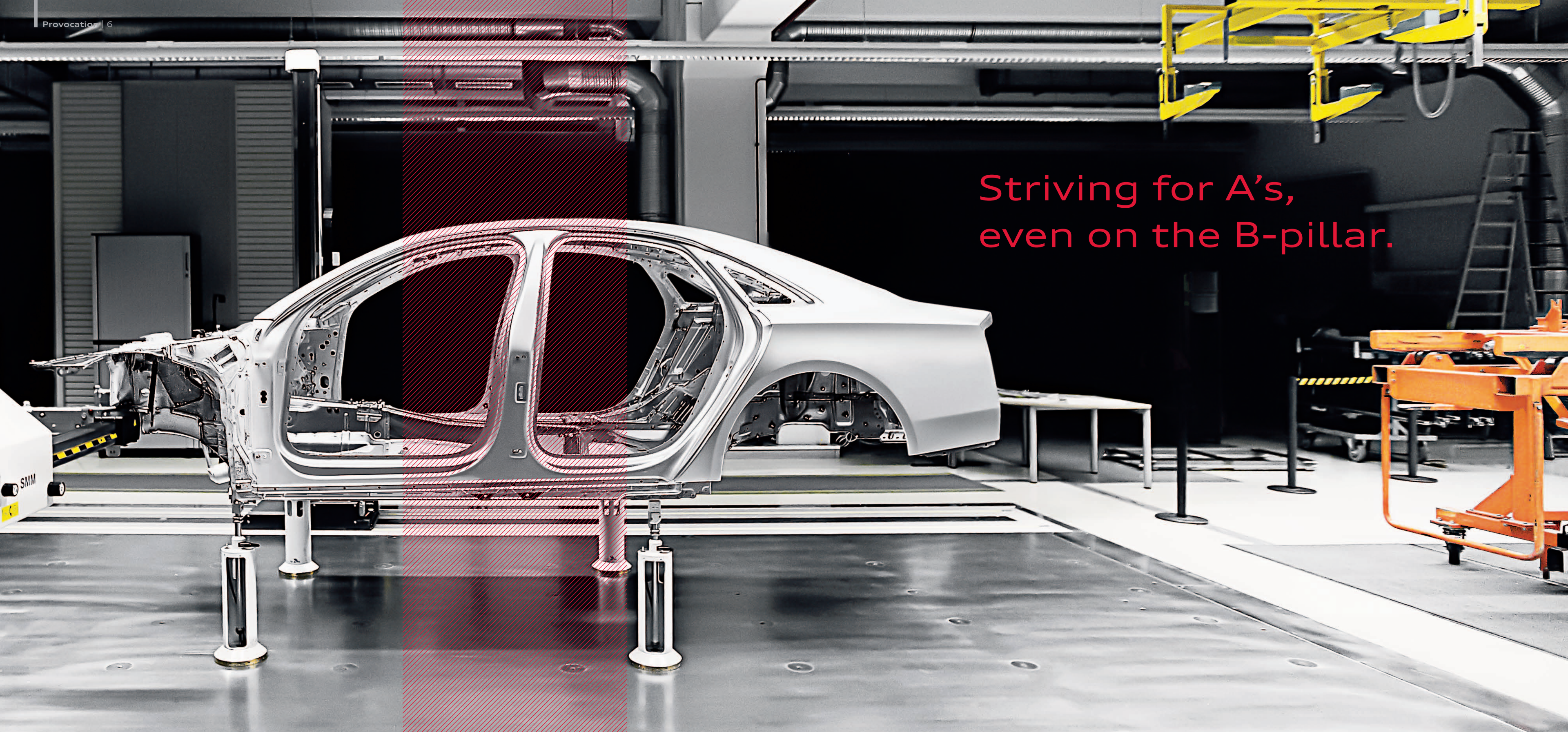

Striving for A's,
even on the B-pillar.

Lightweight design

The need to satisfy increased safety demands has led to increases in vehicle curb weights, dramatically compromising overall performance and efficiency. Of course, we saw that as an engineering challenge to overcome. Our progressive solution was integrative, geometrical and technological lightweight design. It's an approach that balances the functional requirements of individual parts with the overall composition of the vehicle. In other words, through an innovative use of lighter materials, improved design and visionary engineering, we can help reduce the static weight, improve handling, maintain strength and provide greater fuel efficiency for our vehicles.¹

Tailor-made blanks

Using tailor-made blanks helps us counter the convention that solid steel is a better choice. We use them to save weight for better braking performance and improved overall rigidity and strength. It's an innovation that helps provide structural support where it is most needed while allowing for flexibility elsewhere. Joining sheet metals of varying tensile strengths prior to bonding and welding, tailor-made blanks allow us to build a superior frame.

**Engineering defines our models,
and built our company.**

It's not exactly right to say we like to be graded, but Germans are encouraged from an early age to go into precise disciplines. Not just engineering, but mechanical engineering. And even there, we strive to be as precise as we can be. Take this B-pillar. It is the only steel used in this aluminum frame. It consists of ultra-high-strength steel on the outer ridge and advanced high-strength steel on the interior, helping provide strength where it's needed most. It helps protect the cabin in side collisions, while reinforcing the frame in rollovers, helping protect those in the cabin. It was complex to conceive, difficult to execute and a perfectly understandable choice for a company that believes in Truth in Engineering® first. A truth that deserves an A+.

¹ See www.fueleconomy.gov for EPA estimates. Your mileage will vary.





Why we're obsessed with your weight.

78 lb mass reduction
 could save
324 gal over 150,000 miles¹

Lighter is better.

Take a pound off, and you might not notice how much more efficient you have become. Take 75 or more off, and you might be cornering like you never have before. We're talking about your Audi, of course. By taking significant weight off a traditional steel frame, we save hundreds of gallons of gas over the driving life of your car, compared to heavier vehicles. But it's not all about efficiency. We also build aluminum hybrid and steel frames for rigidity and sharper handling. Audi ultra is a comprehensive approach that helps improve braking distance and fuel efficiency while enhancing performance.¹ By challenging ourselves, we've built vehicles that show you how much more you can do, and enjoy, with less.

¹ Based on 150,000 miles driven and EPA estimates of 21 mpg (combined city/highway) for 2011 A6 3.0T quattro® with Tiptronic® automatic transmission and 22 mpg (combined city/highway) for 2012 A6 3.0T quattro® with Tiptronic® automatic transmission. Your mileage will vary.



Conceived for the weather. Built for the road.



The evolutionary quattro®

We knew that for the question “How can we tame German roads?” Audi quattro® all-wheel drive was the answer. Since 1980, we’ve produced an expanding vision of what progressive all-wheel technology can deliver. We didn’t simply look at it as something to use in poor conditions, but rather as a performance technology that’s built to handle roads from the Alps to the autobahn—and points beyond. You’ve seen Audi quattro® capabilities in the way we dominated the

world road rally circuit for years, and in the grip you have in poor conditions and the variable rear-wheel-biased power you enjoy in good ones. For more than 30 years, we have continued to refine the technology, adding an Audi quattro® with sports differential to help maximize performance, and torque vectoring to assist with cornering traction while improving handling. We progressed while the world was trying to catch up, staying on top by building on an impressive heritage of performance.^{1,2}

Distributed power to front—40%¹

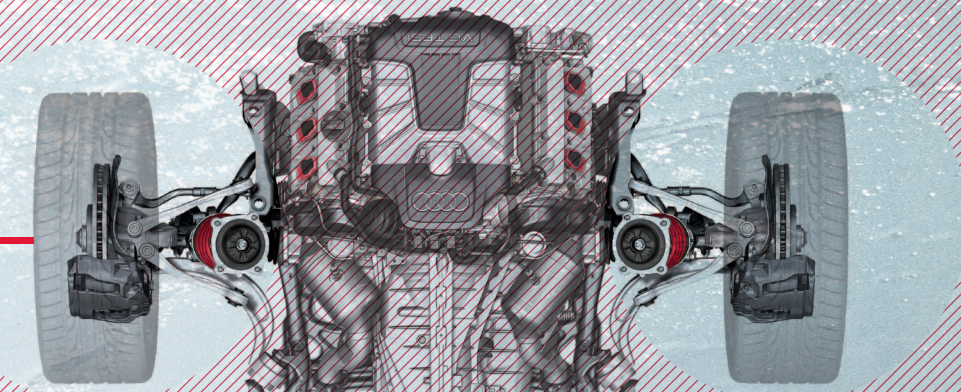

Self-locking center differential²

Torque vectoring²

Asymmetric torque split^{1,2}

Sports differential²

Distributed power to rear—60%¹

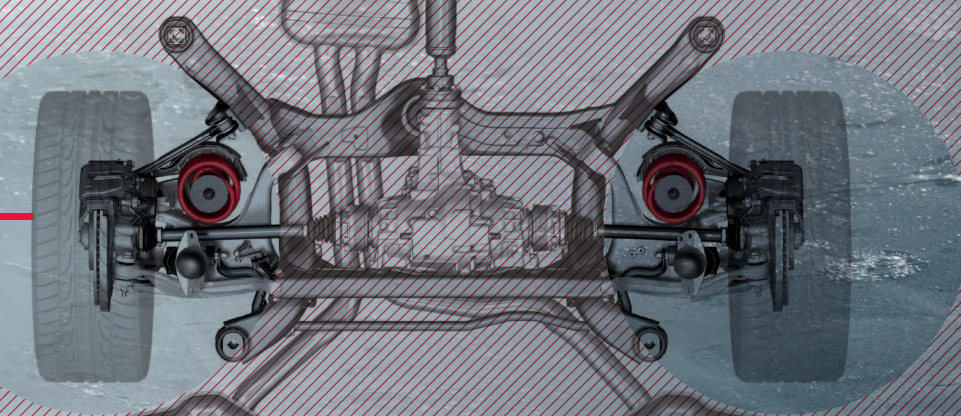

Torque vectoring

You’ll find truth in your corner. Torque vectoring is a handling feature that seems to respond to your impulses before your steering input. An evolution of cross-axle lock, this system works within the Audi quattro® all-wheel drive system while utilizing Electronic Stability Control (ESC) and the Anti-lock Braking System (ABS) to help sense reduced load or wheel-spin on the inner cornering tire, making turns smoother and more responsive.²

European model shown with optional equipment. ¹ Torque split ratio will vary from model to model. ² Features listed may not be available on all models.

+ Ingolstadt, Climate

Lowest recorded temperature: -31° F
Highest recorded temperature: 98.6° F
Average yearly precipitation: 25.98 in
Average yearly dew point: 37.4° F



Driving that demands a response from you too.

Audi drive select Germans are pretty direct. Some might say provocative. And they expect a response in return. You see it in our customizable Audi drive select. We've provided some great driving dynamics in our vehicles: world-class handling, thrilling power, and gripping Audi quattro® all-wheel drive. All for driving that controls the road, so you feel connected to the drive. With Audi drive select, you choose from Individual, Comfort, Dynamic or Auto settings that configure the throttle, transmission, steering, suspension and, if available, the sports differential, to respond to your desires, or the conditions. Or maybe you just want to experiment with drive settings that can take you down hard uptown roads in comfort or out of town in a thrilling blur.¹

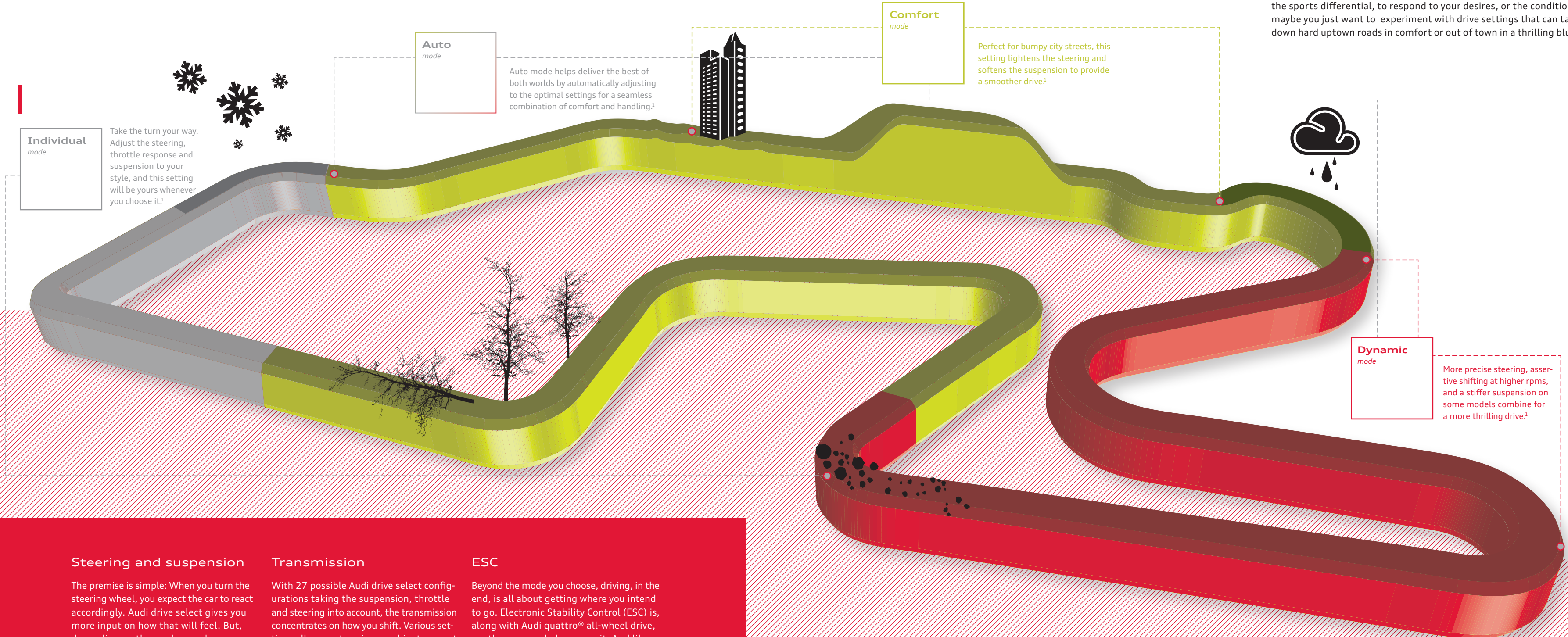

Individual mode

Take the turn your way. Adjust the steering, throttle response and suspension to your style, and this setting will be yours whenever you choose it.¹

Auto mode

Auto mode helps deliver the best of both worlds by automatically adjusting to the optimal settings for a seamless combination of comfort and handling.¹

Comfort mode

Perfect for bumpy city streets, this setting lightens the steering and softens the suspension to provide a smoother drive.¹

Dynamic mode

More precise steering, assertive shifting at higher rpms, and a stiffer suspension on some models combine for a more thrilling drive.¹

Steering and suspension

The premise is simple: When you turn the steering wheel, you expect the car to react accordingly. Audi drive select gives you more input on how that will feel. But, depending on the mode you choose, we take it further. For stiffer suspension and a sportier ride, select Dynamic mode. Or go for Comfort mode, which helps soften the suspension for more comfortable and forgiving handling over difficult roads. In any mode, Audi handling reflects the style you choose, sensitive or relaxed, making steering an extension of your mood.¹

Transmission

With 27 possible Audi drive select configurations taking the suspension, throttle and steering into account, the transmission concentrates on how you shift. Various settings allow you to enjoy punchier torque at higher rpms for a more thrilling drive, or to choose a more luxurious, comfortable one. It's a progressive way to engage finely tuned technology, making it work the way you want it to.¹

ESC

Beyond the mode you choose, driving, in the end, is all about getting where you intend to go. Electronic Stability Control (ESC) is, along with Audi quattro® all-wheel drive, another way we help ensure it. And like quattro®, it's as much of a handling feature as it is a means of control. It helps you corner better, while also acting as an active assistant that helps you react to oversteer or understeer. By activating the right brakes at the right time, ESC helps detect and minimize skids. So you stay on your intended course and get where you want to go.¹

¹ Features listed may not be available on all models.





The case for intolerance.



Precise construction and seamless laser welding

Without looking at the numbers, you might look at the panel seam on the opposite page and see a perfectly aligned contour. But our engineers and assembly-line workers would know it was off. They would note, correctly, that in some places, the weld or seam is clearly less than a millimeter off. Such is the case for intolerance. Anything less than perfect makes your vehicle more susceptible to wear. Precise, safer engineering requires a rigid disdain for allowances. Anything less means your Audi has a slight flaw. And that would make us generous to a fault.

The novel, Frankenstein
Victor Frankenstein attended University
in Ingolstadt in the public novel
Frankenstein by Mary Shelley

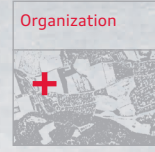



Unafraid to stare back.

LED lighting technology

Naturally, given the trait and the field, it was a German who brought introspection into psychology. The man's name was Wilhelm Wundt, and in Leipzig, in 1879, he saw introspection as a way to figure out the workings of the human mind. In other words, looking inside yourself and talking about what you see and feel was a way to illuminate the process of thought. Suitably inspired, Audi designers took it further and turned Wundt's thesis inside out—thinking of a better way to showcase the process and psychology of illumination. You might even say our iconic, signature LED headlight technology is an expressive, extroverted response to introspection.

We crafted our LED lights not only to illuminate, but to see and be seen. To come as close as we could to re-creating daylight, while doing it as stylishly as possible¹. Immediately recognizable from a distance and supremely attractive up close, each LED light lasts around 10,000 hours, while LED taillights illuminate faster than conventional brake lights to help give the drivers behind you more time to respond. But these lights reflect something deeper and more compelling. Maybe it's the iconic shape. Maybe it's how when you look inside for inspiration, you manage to express yourself to the world².

¹ Based on brightness comparison to the sun and 5,500 K color temperature. Full LED headlights are an optional upgrade. ² Features listed may not be available on all models.



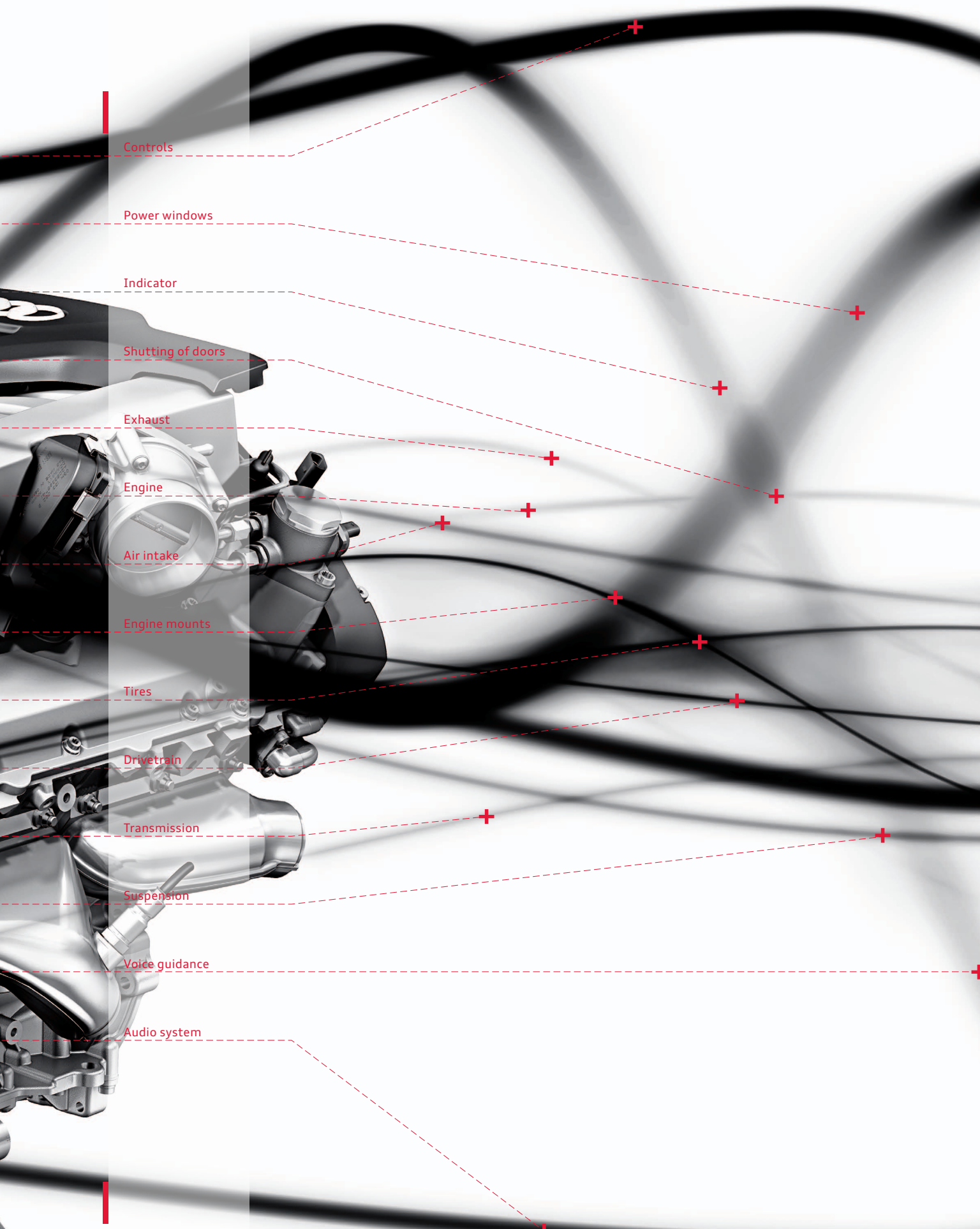

You might hear a little Beethoven in your drivetrain.

A symphony of sound engineering

It's like your very own ode to joy. Audi sound engineers don't simply make the cabin acoustics sound perfect for your music, they make the drivetrain sing. Or, if not sing, then put it in harmony with every other element of the driving experience. From the sound of a shutting door, to the click of a knob being turned, to the full integration of Bang & Olufsen® or BOSE® sound systems, there's an orchestra of engineering. Emphasizing the drama in sound is something Beethoven knew well. It's no surprise that we've picked up on it.¹



1. Features listed may not be available on all models.

The strange beauty of painstaking engineering.

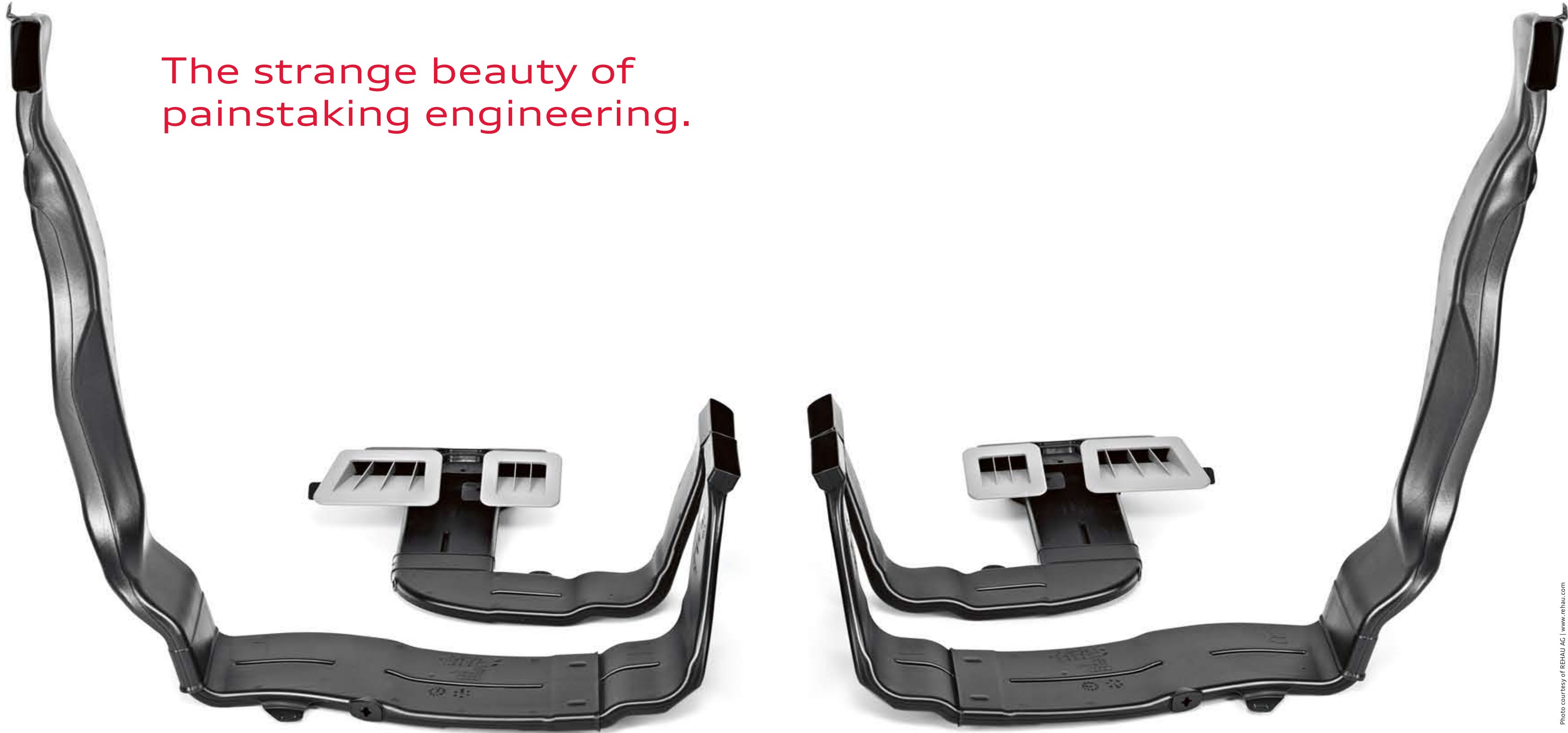

Photo courtesy of REHAU AG | www.rehau.com

Interior design and harmony

At first glance, it's the kind of thing a guy in a black turtleneck might be ruminating over at a Berlin gallery. But then, he might not fully appreciate the sublime design and surprising engineering of the ventilation system in an Audi. In other words, those curves don't just look arresting, they actually help the air to flow more effortlessly and easily around the cabin. That makes the climate control system more responsive, quieter and more effective. You don't need an Art History degree to fully appreciate the impact this sculpture can have on you.



Taking a recommendation a little too far.



Autobahn performance on American roads

Everyone knows there is no speed limit on vast stretches of the autobahn. But there is a recommended one—130 km/h (around 80 mph). That inspired us to build performance vehicles that not only could reach that easily, but push past it effortlessly to the upper reaches of the gauges, as the road demanded.¹ At the same time, we anticipated a different challenge, the American interstate highway system. How do you build progressive luxury performance vehicles for such vastly different kinds of highways? Our response: Plan for power. And anticipate a need for efficiency.

Our engineers crafted an innovative solution with lighter, forced induction engines designed for better response, enhanced fuel economy and quick, torque-driven acceleration.² With FSI and TFSI engines that produce more power from smaller displacement, we take full advantage of the opportunities afforded by the autobahn. But with those same engines and vehicles, we've also designed a luxury vehicle for the open road of America, with improved mpg to take you farther on a single tank of fuel.^{2,3} By taking a German recommendation to heart, we put progressive luxury on the American highways.

FSI®

Conventional thinking isn't part of the Audi DNA. Which is why the Audi FSI direct injection fuel management and delivery system directly injects fuel into the combustion chambers at precisely managed times and depths. What that means for drivers is that a fully homogenized intake charge helps increase power while also reducing fuel consumption. Making efficiency more powerful.²

TFSI®

At Audi, TFSI represents a combination of two of the brand's core areas of expertise—direct injection and forced induction. By adding forced induction (turbocharging or supercharging) to Audi FSI direct injection, the pressurized intake charge is cooled by directly injected fuel, thus achieving efficiency and performance combined with higher compression ratios—previously only attainable by naturally aspirated engines.²

¹ Always obey local speed and traffic laws. ² See www.fueleconomy.gov for EPA estimates. Your mileage will vary. ³ Vehicle range is based on EPA mpg (highway) estimates and the size of the vehicle's fuel tank.

What you see:

- Storm clouds
- Fog
- Is that a jogger?
- Rock slide zone
- Cliff
- Grass
- Cell phone obstruction
- Rock wall
- Sharp turn
- Poorly maintained road
- Puddle
- Loose gravel
- Road curve

What Audi sees:

- Weather information²
- LED daytime running light technology²
- Thermal imaging²
- Head-up display²
- Alopecurus myosuroides
- Audi quattro® all-wheel drive²
- Wi-Fi hotspot²
- Side-impact airbags¹
- Crumple zone
- ASF® aluminum space frame²
- Audi drive select²
- ABS
- ESC

Designing innovation depends on how you see the world.

Where some might look at a country road and see a tough drive, we see innovation, just waiting to be developed, because we see things from a different perspective. Maybe it's from those days of endless rain and snow we get in Ingolstadt. But where others see a wet

road, or a twisty mountain pass, we see solutions such as Audi quattro® or LED daytime running lights. To engineer technologies others haven't thought of yet. To see beyond the curve in order to help keep you comfortably ahead of it. To help you see the Truth in Engineering®.

¹ Airbags are supplemental restraints only and will not deploy under all crash circumstances. Always use safety belts and seat children only in the rear, using restraint systems appropriate for their size and age. ² Features listed may not be available on all models.



A new take on the personal touch.

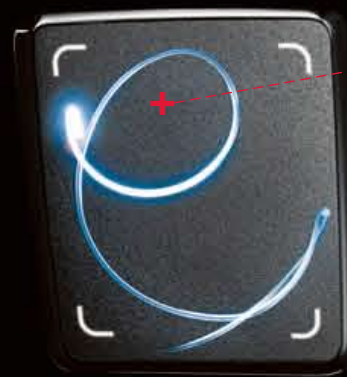

- Letter and number entries¹
- Radio preset selection¹
- Album cover scrolling¹
- Map scrolling¹
- Adjust sound distribution¹

- Mobile Wi-Fi hotspot^{1,2}
- Google Earth™ with 3D topography maps^{1,2}
- Google™ Local Search^{1,2}
- News feeds^{1,2}
- Weather information^{1,2}
- Traffic updates^{1,2}
- myAudi Destinations feature^{1,2}
- Reported gas prices^{1,2}
- Communication^{1,2}
- Vehicle systems^{1,2}
- Entertainment^{1,2}



Audi MMI® From a certain perspective, we've come full circle. Germany was the home to the first moveable type printing press, a technological advancement that standardized text and led to a global revolution in how people accessed information. Audi wanted to bring back a little of the personal touch, while giving you even more communicative capabilities. With handwriting-recognition technology, MMI touch helps deliver the information, entertainment or media you want, when you want it. More than intuitive, you can access the right phone number or the right song with just a few quick strokes of your finger on the touchpad. It connects you to your car in an entirely new way, allowing you to easily and

immediately communicate with your vehicle and its systems. Communication is further enhanced with the innovative Audi connect, which features the industry's first Google Earth™-enabled infotainment system and Wi-Fi hotspot capabilities.² Audi connect helps you get up-to-the-minute information with a few quick, easy cues—allowing you connection to everything from local fuel prices to traffic and points of interest.² If the printing press helped democratize knowledge, Audi MMI gives you a personalized nerve center for you to receive customized information through Audi connect that was made just for you, making for a truly individualistic informational experience.¹

1. Features listed may not be available on all models. 2. Requires a data subscription plan. Distracted driving can cause a loss of vehicle control. The features and technologies discussed above are offered for convenience, and should be used only when it is safe and appropriate. The Wi-Fi hotspot feature is intended for passenger use only. Always pay careful attention to the road, and do not drive while distracted.



University of Ingolstadt
 Founded in 1472 by Louis the Rich, the Duke of Bavaria at the time, its first Chancellor was the Bishop of Eichstätt. It consisted of five faculties: humanities, sciences, theology, law and medicine.

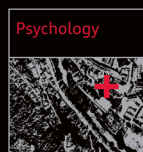

The most historic plug-in since Newport '65.

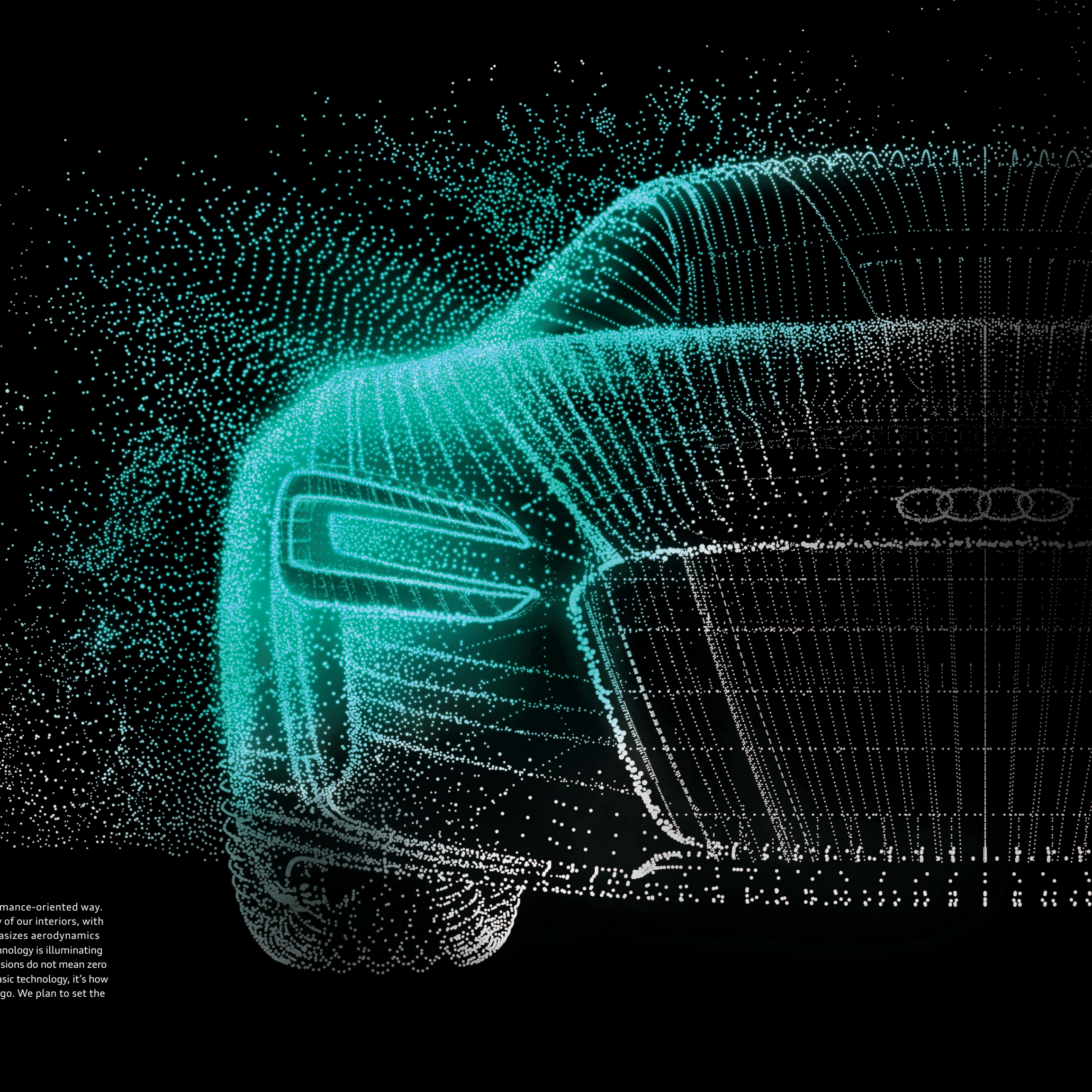

Audi e-tron™

In music, everything changed when a certain Fender® Stratocaster® was plugged in at the Newport Folk Festival in 1965. Sure, rock and roll had been part of the culture, but that Fender® transformed how people experienced it. Audi looks to do the same with plug-in electric vehicles. Called e-tron, we're going beyond the existing technology and making it the kind of showcase of progressive engineering, lightweight construction and innovative thinking that will make it unmistakably Audi. Power, speed and range

will be expressed in a primal, performance-oriented way. We will also maintain the deep luxury of our interiors, with envelope-pushing design that emphasizes aerodynamics along with stunning lines. And the technology is illuminating too. Our engineers know that zero emissions do not mean zero emotion. It's not enough to have the basic technology, it's how far past convention you are willing to go. We plan to set the new standard for electric plug-ins.

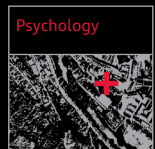

Sometimes higher calories can be a good thing.

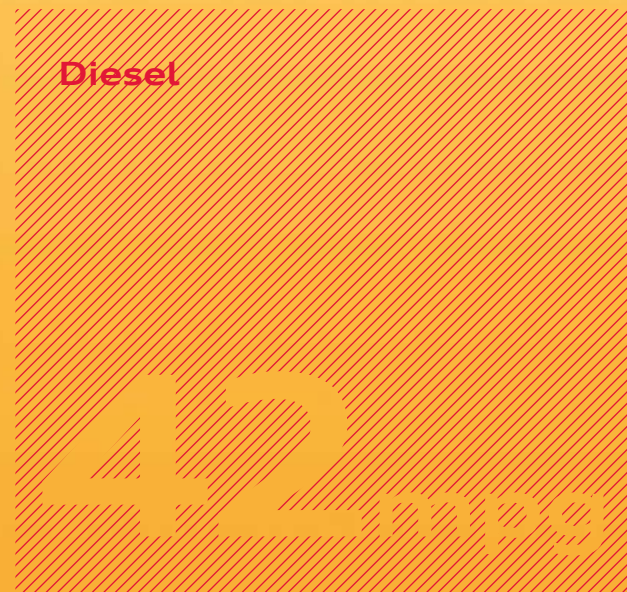

TDI® innovation Like it or not, it's long been true that one of the differences between Germans and Americans is their approach to beer. Germans are generally unconcerned with calories or cost, so long as the beer tastes good. Americans have, for a long time, gone with lighter, cheaper beers. But as the microbeer revolution in America has shown, American's tastes are changing. As with beer, so goes diesel. America is increasingly consuming Audi TDI® clean diesel technology. Maybe it's the efficiency. Calories are, after all, only a measure of potential energy. They may not cause German beer to taste better than their mass-brewed American counterparts, but calories certainly make

diesel fuel more powerful than gasoline. Which means that a gallon of diesel fuel has about 30% more energy than a comparable amount of gas and combusts more efficiently in the engine. Maybe it's because the Audi TDI® clean diesel engine has achieved ultra-low emissions vehicle (Bin-5/ULEV) status in all 50 states while producing 20 percent less CO₂ emissions than traditional gasoline. Maybe it's the way that Audi has dominated the 24 Hours of Le Mans over the years with Audi TDI® clean diesel vehicles. Or maybe, in the end, it's the calories that have changed minds. Which goes to show that all fuels are not created equal— but some should be an acquired taste.

1 30 city/42 highway mpg (2012 A3 TDI clean diesel with Audi S tronic® transmission). EPA estimates. Your mileage will vary. 2 22 city/28 highway mpg (2012 A3 2.0T with Audi S tronic® transmission and FrontTrak® front-wheel drive). EPA estimates. Your mileage will vary.



The case for truth.

Audi makes a powerful one. One where engineering takes center stage and visionary technologies like ASF® aluminum space frames, Audi MMI® touch and Audi quattro® all-wheel drive make the driver's experience a more rewarding one. From weight savings to exciting innovations to unparalleled handling, when we say Luxury has Progressed, this is what we mean. Audi takes all the innovative and intrinsic influences of Germany to create an undeniably potent truth. And the truth is, we can back it up. Audi incorporated diesel engines into our lineup more than 20 years ago, and we've only improved on their power, their fuel mileage and their emissions to the point where Audi TDI® has a Le Mans championship pedigree—and is a leader in clean diesel technology. Then there are our innovations in Audi FSI® and TFSI® engines and our use of stylish and functional LED lighting technologies that help set us apart. To say nothing of revolutionary handwriting-recognition technology in the available MMI touch and next-generation navigation with Audi connect, the world's first in-vehicle navigation system to be integrated with Google Earth™.¹

These are the cars that contain this truth. These inspirations. These innovations. They are the proof behind the Truth in Engineering®.

A3

Engineering defines the Audi A3 by elevating performance while enhancing efficiency. Whether you choose the efficient 2.0T, which gets an estimated 30 mpg on the highway, or the ultra-efficient Audi TDI® clean diesel with an impressive 42 mpg/highway estimate,² you might overlook how ripped and responsive the A3 is when you get out driving. With its exhilarating combination of power and efficiency, it's a luxury car that engages the mind as much as it thrills the soul.



A3 Standard Feature Highlights

- 17" 5-split-spoke design alloy wheels with all-season tires
- Audi S line® exterior appearance
- Leather seating surfaces
- Split folding 60/40 rear seatbacks
- Concert radio with ten speakers and SiriusXM Satellite Radio¹
- Dual-zone automatic climate control

A3 Premium Plus

- 17" 10-spoke design alloy wheels with all-season tires
- Xenon plus headlights with LED daytime running light technology
- Leather-covered, three-spoke multifunction steering wheel with shift paddles (Audi S tronic® transmissions only)
- Eight-way power driver's seat (includes four-way power lumbar adjustment)
- BLUETOOTH® wireless technology preparation for mobile phone

¹ See back cover for important information about summer performance tires, required infotainment subscriptions, Audi MMI® Navigation plus, and distracted driving. ² See www.fueleconomy.gov for EPA estimates. Your mileage will vary.

A4

A4 | A4 Avant | S4

The Audi A4 is defined by the way it entices, delivering progressive luxury through ample power, efficiency and sleek design in either sports sedan or Avant models. Choose the available Audi quattro® all-wheel drive for performance or an optional Bang and Olufsen® Sound System to enhance an already stylish drive. Its finely tuned S4 variant delivers potent performance, with a supercharged 333-hp 3.0T V6 that can go from 0 to 60 mph in as little as 4.9 seconds.



A4 / A4 Avant Standard Feature Highlights

A4 Premium

- 17" 10-spoke-star design alloy wheels with all-season tires
- Panoramic sunroof (Avant only)
- Leather seating surfaces
- Eight-way power front seats (includes four-way power lumbar adjustment for driver)
- Audi premium sound system with ten speakers and SiriusXM Satellite Radio¹

A4 Premium Plus

- 18" 10-spoke design alloy wheels with all-season tires
- Audi S line® exterior appearance
- Xenon plus headlights with LED daytime running light technology
- Heated front seats
- Driver seat memory
- Three-zone automatic climate control
- Audi music interface with iPod® integration

A4 Prestige

- Adaptive xenon plus headlights with LED daytime running light technology
- Audi MMI® Navigation plus with voice control system¹
- Bang & Olufsen® Sound System with 14 speakers
- HD Radio™ technology
- Audi advanced key
- Audi side assist
- Parking system with rear sensors



S4 Standard Feature Highlights

S4 Premium Plus

- 18" 5-parallel-spoke design alloy wheels with summer performance tires¹
- S4 sport suspension calibration
- S exterior appearance
- Xenon plus headlights with LED daytime running light technology
- Twelve-way power front S sport seats (includes four-way power lumbar adjustment)
- Heated front seats
- Audi music interface with iPod® integration
- BLUETOOTH® wireless technology preparation for mobile phone

S4 Prestige

- 19" 5-segment-spoke design alloy wheels with summer performance tires¹
- Adaptive xenon plus headlights with LED daytime running light technology
- Audi MMI® Navigation plus with voice control system¹
- Bang & Olufsen® Sound System with 14 speakers
- HD Radio™ technology
- Audi advanced key
- Audi side assist
- Parking system with rear sensors

A5

A5 Coupe
A5 Cabriolet
S5 Coupe
S5 Cabriolet

The Audi A5 is a prime example of passionate, expressionist style and finely tuned performance. In either its Coupe or Cabriolet identity, the A5 is a showcase of personality—as it should be—with its assured handling, smart interior and devilish stance. It's technologically advanced, fully stacked with available advanced technologies like Audi MMI® and a Bang and Olufsen® Sound System, and viscerally powerful whenever you hit the throttle, with a potent 2.0T, or especially in the S5 with a 3.0T (Cabriolet only) or 4.2 FSI® (Coupe only)—engines that offer athleticism, but with a smile instead of a scowl.



S5 Coupe / S5 Cabriolet Standard Feature Highlights

S5 Premium Plus

- 19" 5-parallel-spoke-star design alloy wheels with summer performance tires¹
- S5 sport suspension calibration
- S exterior appearance
- Xenon plus headlights with LED daytime running light technology
- Silk Nappa leather seating surfaces and trim

- Twelve-way power front S5 sport seats (includes four-way power lumbar adjustment)
- Heated front seats
- Audi music interface with iPod® integration
- BLUETOOTH® wireless technology preparation for mobile phone
- HomeLink® remote transmitter

S5 Prestige

- Adaptive xenon plus headlights with LED daytime running light technology
- Audi MMI® Navigation plus with voice control system (voice control system not available on S5 Cabriolet)¹
- Color driver information system
- Bang & Olufsen® Sound System
- HD Radio™ technology
- Audi side assist
- Parking system with rear sensors

A5 Coupe / A5 Cabriolet Standard Feature Highlights

A5 Premium

- 18" 10-spoke-V design alloy wheels with all-season tires (Coupe)
- 18" 15-spoke-star design alloy wheels with all-season tires (Cabriolet)
- Panoramic tilting sunroof (Coupe only)
- Eight-way power front seats (includes four-way power lumbar adjustment for driver)
- Audi premium sound system with ten speakers and SiriusXM Satellite Radio¹

A5 Premium Plus

- Xenon plus headlights with LED daytime running light technology
- Heated front seats
- Driver seat memory
- Three-zone automatic climate control
- Audi music interface with iPod® integration
- BLUETOOTH® wireless technology preparation for mobile phone
- HomeLink® remote transmitter

A5 Prestige

- Adaptive xenon plus headlights with LED daytime running light technology
- Audi MMI® Navigation plus with voice control system (voice control system not available on A5 Cabriolet)¹
- Color driver information system
- Bang & Olufsen® Sound System
- HD Radio™ technology
- Audi side assist
- Parking system with rear sensors



¹ See back cover for important information about summer performance tires, required infotainment subscriptions, Audi MMI® Navigation plus, and distracted driving.

A6

The Audi A6 makes the road more intelligent. With innovative Audi connect with Google Earth™ capabilities, Audi MMI® touch with advanced handwriting-recognition technology and Wi-Fi connectivity all available, you can see why.¹ And with a suite of available driver assistance technologies that monitor and help you react to the traffic environment around you, it becomes a celebration of automobile technology. It's also a celebration of what progressive luxury can be when engineered to be a lightweight, agile and supremely confident performance vehicle.



A7

Design something no one has ever seen before. And make it an ultrastylish, high-performance luxury vehicle so bold it wants to transform the world around it. We're now in the rarified air of the Audi A7, a five-door luxury performance coupe that's a beacon of unconventional thinking. It gives power a lot of style. It gives design some serious technology. And it gives people something to think about when they think they have seen it all.



European model shown with optional equipment.

A6 Standard Feature Highlights

A6 Premium

- Aluminum hybrid construction—aluminum exterior body panels and a steel frame
- 17" 10-spoke design alloy wheels with all-season tires
- Heated front seats (3.0T only)
- Three-zone automatic climate control
- Audi MMI® Radio plus with ten speakers and SiriusXM Satellite Radio¹
- Audi music interface with iPod® integration
- BLUETOOTH® wireless technology preparation for mobile phone
- Audi drive select

A6 Premium Plus

- 18" 5-arm design alloy wheels with all-season tires
- Xenon plus headlights with LED daytime running light technology
- Audi MMI® Navigation plus with voice control system and Audi MMI® touch¹
- Audi connect and Google Earth™ with 3D satellite maps, Google™ Local Search, weather information, news feeds, and Wi-Fi hotspot¹
- 7" color driver information system
- HD Radio™ technology
- SiriusXM Traffic

A6 Prestige (3.0T only)

- 18" 5-V-spoke design alloy wheels with all-season tires
- Audi S line® exterior appearance
- Adaptive xenon plus headlights with LED daytime running light technology
- Ventilated front seats
- Four-zone automatic climate control
- BOSE® sound system with 14 speakers and AudioPilot® noise compensation
- Audi advanced key

A7 Standard Feature Highlights

A7 Premium

- Aluminum hybrid construction—aluminum exterior body panels and steel frame
- 18" 7-spoke design alloy wheels with all-season tires
- Xenon plus headlights with LED daytime running light technology
- Three-zone automatic climate control
- Audi music interface with iPod® integration
- BLUETOOTH® wireless technology preparation for mobile phone
- Audi drive select

A7 Premium Plus

- 19" 10-spoke design alloy wheels with all-season tires
- Audi MMI® Navigation plus with voice control system and Audi MMI® touch¹
- Audi connect and Google Earth™ with 3D satellite maps, Google™ Local Search, weather information, news feeds, and Wi-Fi hotspot¹
- 7" color driver information system
- HD Radio™ technology
- SiriusXM Traffic
- Parking system with front and rear sensors

A7 Prestige

- Audi S line® exterior appearance
- Adaptive xenon plus headlights with LED daytime running light technology
- Ventilated front seats
- Four-zone automatic climate control
- BOSE® sound system with 14 speakers and AudioPilot® noise compensation
- Audi advanced key



¹ See back cover for important information about summer performance tires, required infotainment subscriptions, Audi MMI® Navigation plus, and distracted driving.



European model shown with optional equipment.

A8

A8 | A8 L | A8 L W12

It's a new class of flagship. The Audi A8 represents the pinnacle of prestige. Exuding style and performance, it is luxury unshackled from traditional expectations. Which is why, along with Audi engineering and design expertise, the A8 offers new technological possibilities, to better connect the driver to the drive while others seem to stand still. It is comfort, innovation and power wrapped in an indelible package of progressive luxury.



A8 Standard Feature Highlights

A8

- ASF® aluminum space frame
- 19" 10-Y-spoke design alloy wheels with all-season tires
- Audi adaptive air suspension
- Adaptive xenon plus headlights with LED daytime running light technology
- Audi MMI® Navigation plus with voice control system and Audi MMI® touch
- Audi connect—Google Earth™ with 3D satellite maps, Google™ Local Search, weather information, news feeds, and Wi-Fi hotspot¹
- BOSE® Surround Sound with 14 speakers and AudioPilot® noise compensation

A8 L

- Audi advanced key
- Four-spoke multifunction steering wheel with shift paddles
- Power rear and rear-side sunshades
- Power soft-closing doors
- Power trunk open/close
- Parking system with front and rear sensors

A8 L W12

- 20" 10-parallel-spoke design alloy wheels with summer performance tires.¹
- Full LED headlight technology
- Dynamic steering
- Panoramic sunroof
- Four-zone automatic climate control
- 22-way power comfort front seats (includes power lumbar adjustment)
- Ventilated front and rear seats with massage function
- Heated front and rear seats
- Rear Seat Entertainment with dual 10" screens



¹ See back cover for important information about summer performance tires, required infotainment subscriptions, Audi MMI® Navigation plus, and distracted driving. ² See www.fueleconomy.gov for EPA estimates. Your mileage will vary.

TT

TT Coupe | TTS Coupe
TT Roadster | TTS Roadster
TT RS Coupe

The Audi TT is a sports car designed to accelerate and elevate. Start with the impressive engineering, inspired design and gripping performance of the TT. Raise the game with advanced driving dynamics and powerfully efficient Audi TFSI® engines in the TTS.² Reach the pinnacle with the finely tuned 360-hp TT RS. Coupe or Roadster, with Audi quattro® and ASF® aluminum space frame standard throughout the line, Audi builds on the belief that this is the car for drivers who enjoy unrivaled design and true performance while they enjoy the view.



TT Standard Feature Highlights

TT Premium Plus

- 18" 5-arm-dynamic design alloy wheels
- Xenon plus headlights with LED daytime running light technology
- Three-spoke multifunction, magnesium, flat-bottom, sport steering wheel with shift paddles
- Leather/Alcantara® seating surfaces

- Ten-way power front sport seats (includes four-way lumbar adjustment)
- Concert radio with nine speakers and SiriusXM Satellite Radio¹
- BLUETOOTH® wireless technology preparation for mobile phone
- HomeLink® remote transmitter

TT Prestige

- Audi Navigation plus with traffic information¹
- BOSE® sound system with twelve speakers and AudioPilot® noise compensation
- Fine Nappa leather seating surfaces and trim
- Heated front seats
- LED interior lighting technology
- Parking system with rear sensors

TTS Standard Feature Highlights

TTS Premium Plus

- 19" tri-spoke design alloy wheels with summer performance tires¹
- S Audi magnetic ride with sport mode
- S exterior appearance
- Xenon plus headlights with LED daytime running light technology
- Silk Nappa leather seating surfaces and trim

- Ten-way power front sport seats (includes four-way lumbar adjustment)
- Concert radio with nine speakers and SiriusXM Satellite Radio¹
- BLUETOOTH® wireless technology preparation for mobile phone
- HomeLink® remote transmitter

TTS Prestige

- Audi Navigation plus with traffic information¹
- BOSE® sound system with twelve speakers and AudioPilot® noise compensation
- Heated front seats
- LED interior lighting technology
- Parking system with rear sensors



TT RS Standard Feature Highlights

TT RS

- 2.5-liter 360-hp five-cylinder engine with Audi TFSI®
- TT RS engine cover in carbon fiber
- 14.6" front perforated and ventilated/12.2" rear ventilated disc brakes with high-gloss black finish and RS logo on front callipers
- 19" 5-arm-rotor design alloy wheels with summer performance tires¹
- TT RS front and rear bumpers
- TT RS side mirrors in aluminum matte with integrated LED indicator light technology
- TT RS three-spoke multifunction, magnesium, flat-bottom, sport steering wheel
- Silk Nappa leather seating surfaces and trim with TT RS emblem

R8

R8 Coupe | R8 Spyder

The blur. Yeah, that blur with the sharp yet fluid profile you noticed out of the corner of your eye as it blasted past you in milliseconds. Not Italian, you know that. No, this is something else. Muscular. Resonant. Stylish. The Audi R8. A supercar, yes, but it's not unapproachable, if you can find one in captivity. When still, it's an eye-catching, design-forward sculpture. When unleashed, its 430-hp V8 or 525-hp V10 makes hearts beat harder with just a single rev. But it's the blur on the road that will make the most lasting impression.¹

R8 GT

It may seem like you can't have the Audi R8 GT. You might want to try and control the stunning 560 hp and 398 lb-ft of torque its modified V10 naturally aspirated 5.2-liter direct-injection engine delivers to your adrenal glands. But it is elusive. Can you handle its carbon fiber matte fixed rear wing? Its optional Audi carbon ceramic brakes? Its total expression of Audi engineering and performance design? It's up to you. That is, it's up to you if you take advantage of the ultimate opportunity: being someone who will buy one of the 333 being produced globally.³



R8 Standard Feature Highlights

R8 4.2

- 4.2-liter 430-hp V8 with Audi FSI®
- Audi quattro® all-wheel drive
- 19" 5-arm double-spoke design forged alloy wheels with summer performance tires²
- Audi magnetic ride
- Xenon plus headlights with LED daytime running light technology
- Three-spoke multifunction, magnesium, flat-bottom, sport steering wheel (with shift paddles on models with Audi R tronic® six-speed sequential transmission)

- Audi sideblades in tone-on-tone contrast paint (Coupe only)
- Leather/Alcantara® seating surfaces
- Ten-way power front sport seats (includes four-way lumbar adjustment)
- LED interior lighting technology
- Concert radio with seven speakers and SiriusXM Satellite Radio²
- BLUETOOTH® wireless technology preparation for mobile phone with safety-belt microphone
- HomeLink® remote transmitter

R8 5.2

- 5.2-liter 525-hp V10 with Audi FSI®
- Carbon fiber Sigma engine compartment inlays (Coupe only)
- Audi quattro® all-wheel drive
- 19" 10-spoke-Y design forged alloy wheels with summer performance tires²
- Audi magnetic ride
- Full LED headlight technology
- Audi MMI® Navigation plus and six-disc CD changer²
- Bang & Olufsen® Sound System with twelve speakers

R8 GT Standard Feature Highlights

R8 GT

- 5.2-liter 560-hp V10 with Audi FSI®
- Audi quattro® all-wheel drive and Audi R tronic® six-speed sequential transmission
- 19" 5-twin-spoke-Y design alloy wheels with titanium finish and summer performance tires²
- R8 GT sport suspension calibration
- R8 GT front and rear bumpers
- R8 GT Audi sideblades in carbon fiber matte
- R8 GT side mirrors in carbon fiber matte

- R8 GT fixed rear wing in carbon fiber matte
- R8 GT LED taillight technology
- Audi Navigation plus and six-disc CD changer²
- R8 GT three-spoke multifunction, magnesium, flat-bottom, sport steering wheel with shift paddles
- R8 GT aluminum gear knob with vehicle production number
- R8 GT leather/Alcantara® seating surfaces

- Ten-way power front sport seats (includes four-way lumbar adjustment)
- R8 GT carbon fiber matte interior inlays
- Black Alcantara® headliner



¹ Always obey local speed and traffic laws. ² See back cover for important information about summer performance tires, required infotainment subscriptions, Audi MMI® Navigation plus, and distracted driving. ³ Limited availability.

Q5

While the segment might be trying to figure it out, the Audi Q5 knows exactly what it is. Call it a crossover, call it an elevated sedan. Whatever you call it, the Q5 is unmistakably an Audi that features a finely honed interior, a sleek exterior style and a well-tuned engine. Engage the available Audi drive select to discover a dynamic power profile. Arrive in stylish comfort. Introduce yourself to a confident Q5.



Q5 Standard Feature Highlights

Q5 Premium (2.0T only)

- 18" 10-spoke-V design alloy wheels with all-season tires
- Aluminum roof rails
- Twelve-way power front seats (includes four-way lumbar adjustment)
- Sliding 40/20/40 split folding second-row seats with adjustable recline
- Three-zone automatic climate control

Q5 Premium Plus (2.0T | 3.2)

- 19" 5-arm-structure design alloy wheels with all-season tires (3.2 only)
- Audi 5 line® exterior appearance (3.2 only)
- Xenon plus headlights with LED daytime running light technology
- Panoramic sunroof and power tailgate
- Audi music interface with iPod® integration
- BLUETOOTH® wireless technology preparation for mobile phone
- Heated front seats and driver seat memory
- Power-adjustable, power-folding, auto-dimming, heated side mirrors with memory
- Audi advanced key (3.2 only)

Q5 Prestige (3.2 only)

- Adaptive xenon plus headlights with LED daytime running light technology
- Audi MMI® Navigation plus with voice control system¹
- Bang & Olufsen® Sound System with 14 speakers
- Audi side assist
- Manual rear side sunshades
- Thermo cup holder



¹ See back cover for important information about summer performance times, required infotainment subscriptions, Audi MMI® Navigation plus, and distracted driving. ² EPA estimates were not available at time of printing.

Q7

A design detail, captured in miniature, can define the character of a piece. So that's one way to think of the Audi Q7: a collection of stylish details that add up to one impressively large canvas. Maybe you'll fall in love with the grain of the burled wood, the room that seats seven, or the touch of the leather seating surfaces. Or maybe you want to look at the available TDI® clean diesel model that can achieve a combined 20 mpg². Whatever is in the details, you are looking at the Q7 for the room, style and stature of a premium SUV that takes performance as seriously as its sizable comforts.



Q7 Standard Feature Highlights

Q7 Premium

- 18" 6-arm design alloy wheels with all-season tires
- Power tailgate
- 12-way power front seats (includes four-way lumbar adjustment)
- Sliding 40/20/40 split folding second-row seats with adjustable recline
- 50/50 split folding third-row seats
- Audi music interface with iPod® integration
- BLUETOOTH® wireless technology preparation for mobile phone
- HomeLink® remote transmitter
- Parking system with rear sensors

Q7 Premium Plus

- Xenon plus headlights with LED daytime running light technology
- Panoramic sunroof
- Audi MMI® Navigation plus with voice control system¹
- Audi connect—Google Earth™ with 3D satellite maps, Google™ Local Search, weather information, news feeds, and Wi-Fi hotspot¹
- BOSE® Surround Sound system with 14 speakers and AudioPilot® noise compensation
- Parking system with front and rear sensors

Q7 Prestige

- 20" 10-spoke-V design alloy wheels with all-season tires (TDI only)
- Audi 5-Line® exterior appearance (3.0T only)
- Warm Weather Package
- Ventilated front seats
- Audi side assist
- Audi advanced key





Picture it.

A7 shown with Cartesia accessory wheels.