

Audi

2017

R8



Audi



*ACCELERATION THAT BLURS
THE FINE LINE BETWEEN
JOY AND THRILL.*



*ACCELERATION THAT BLURS
THE FINE LINE BETWEEN
JOY AND THRILL.*

*ACCELERATION THAT BLURS
THE FINE LINE BETWEEN
JOY AND THRILL.*



*THE LIFETIME ACHIEVEMENT
OF AN ENGINEER CAN PASS BY
IN 3.2 SECONDS.¹*



*THE LIFETIME ACHIEVEMENT
OF AN ENGINEER CAN PASS BY
IN 3.2 SECONDS.¹*

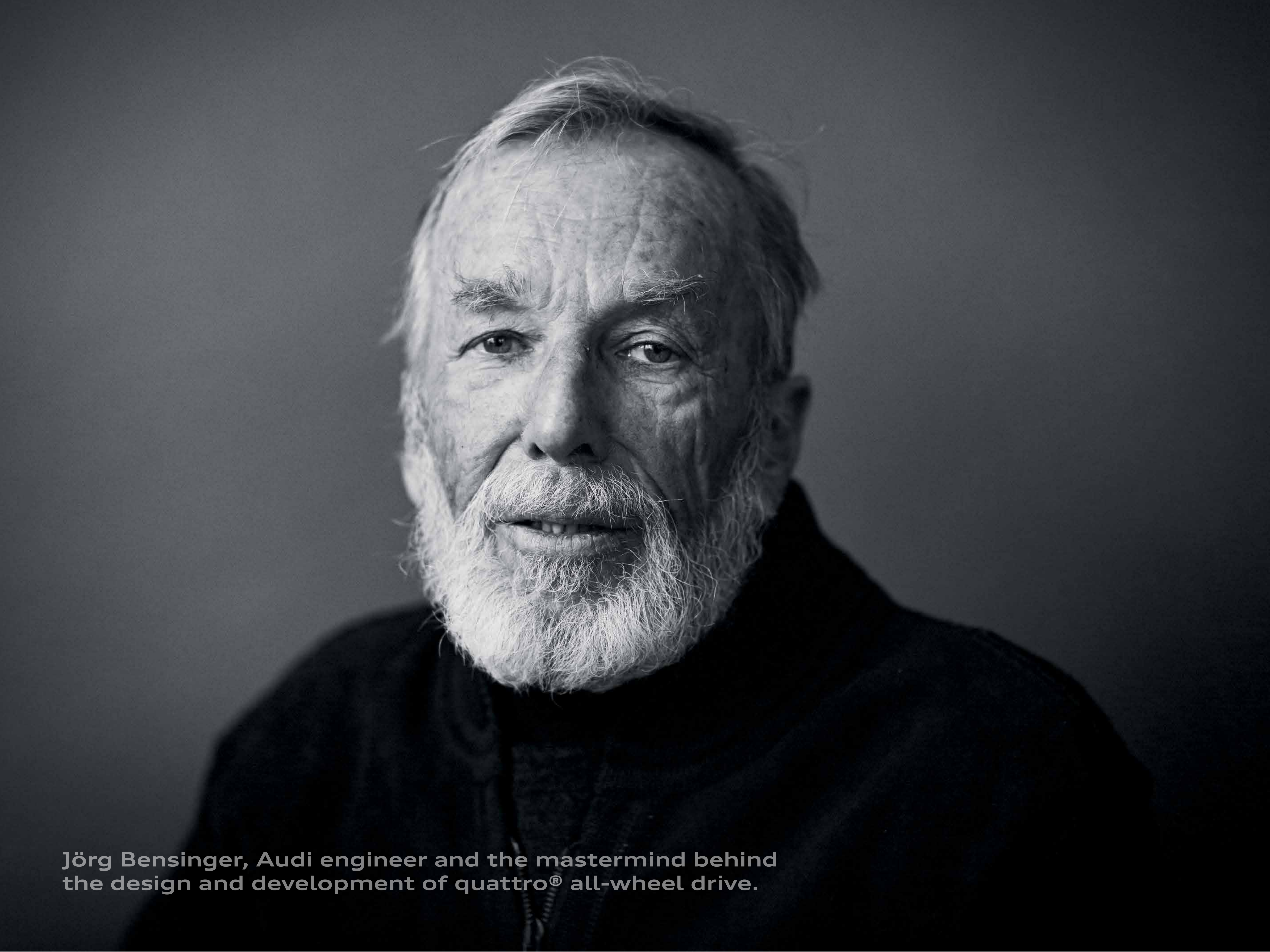

Jörg Bensinger, Audi engineer and the mastermind behind the design and development of quattro® all-wheel drive.

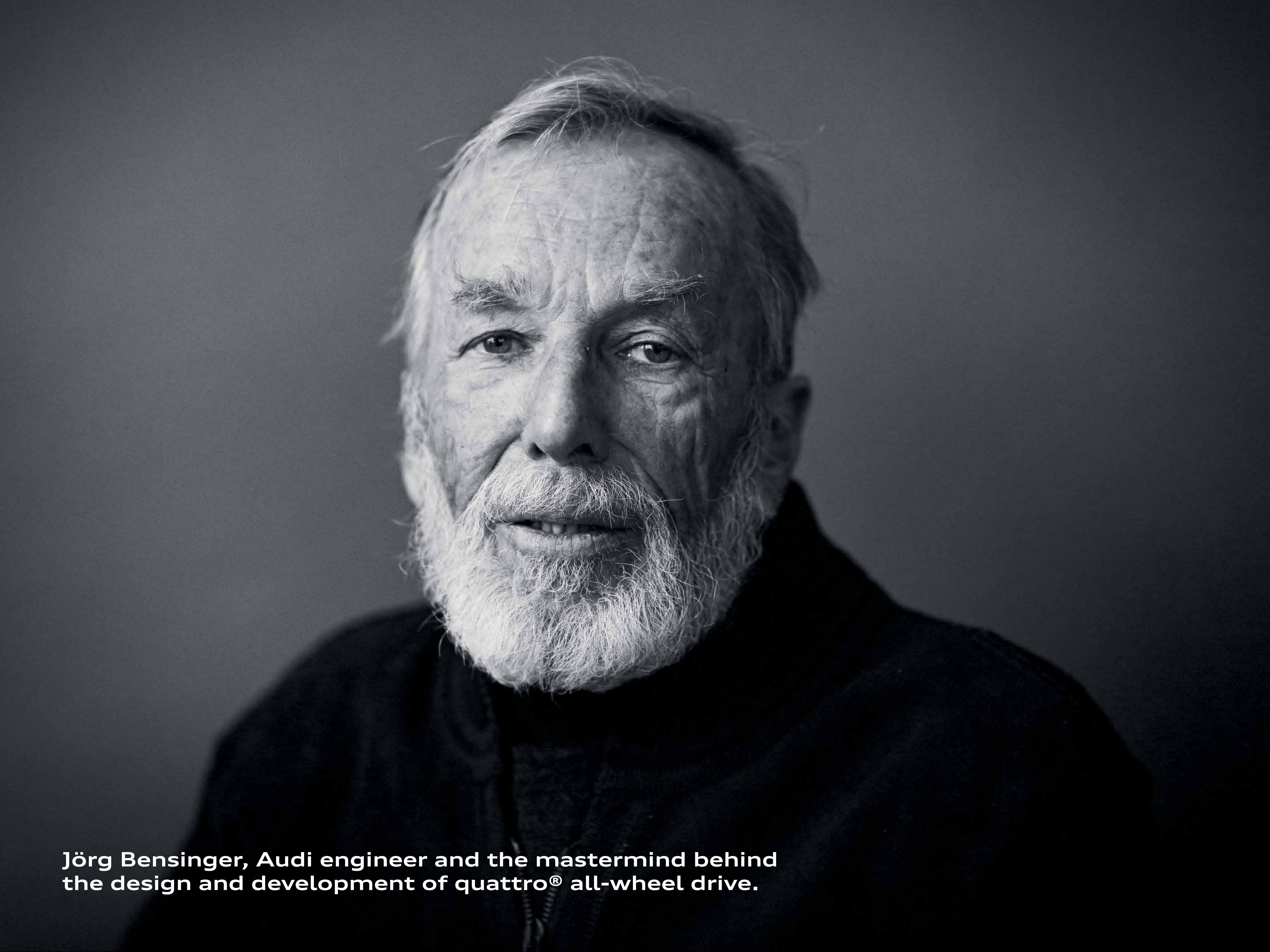

Jörg Bensinger, Audi engineer and the mastermind behind the design and development of quattro® all-wheel drive.

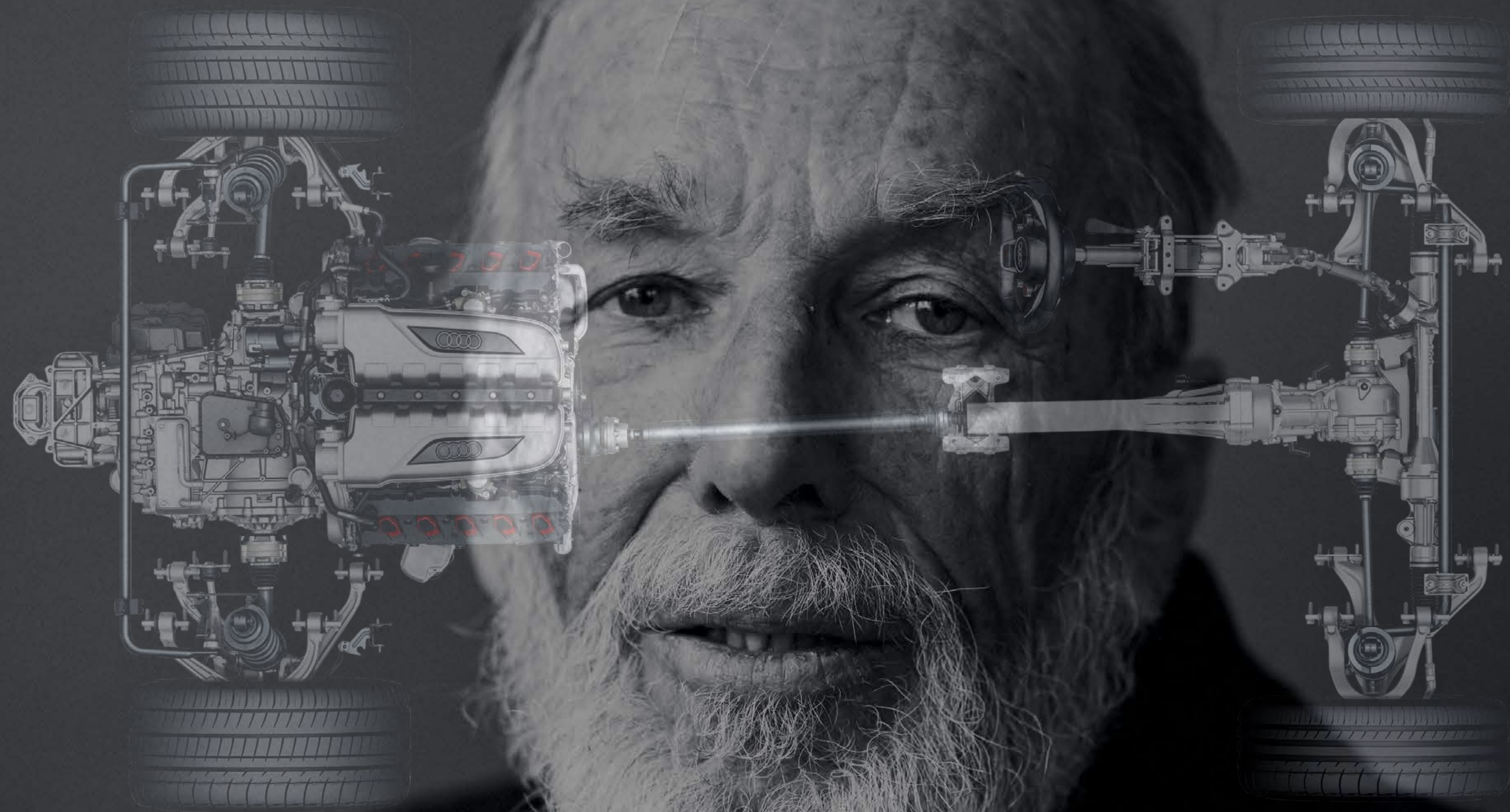

Jörg Bensinger, Audi engineer and the mastermind behind the design and development of quattro® all-wheel drive.

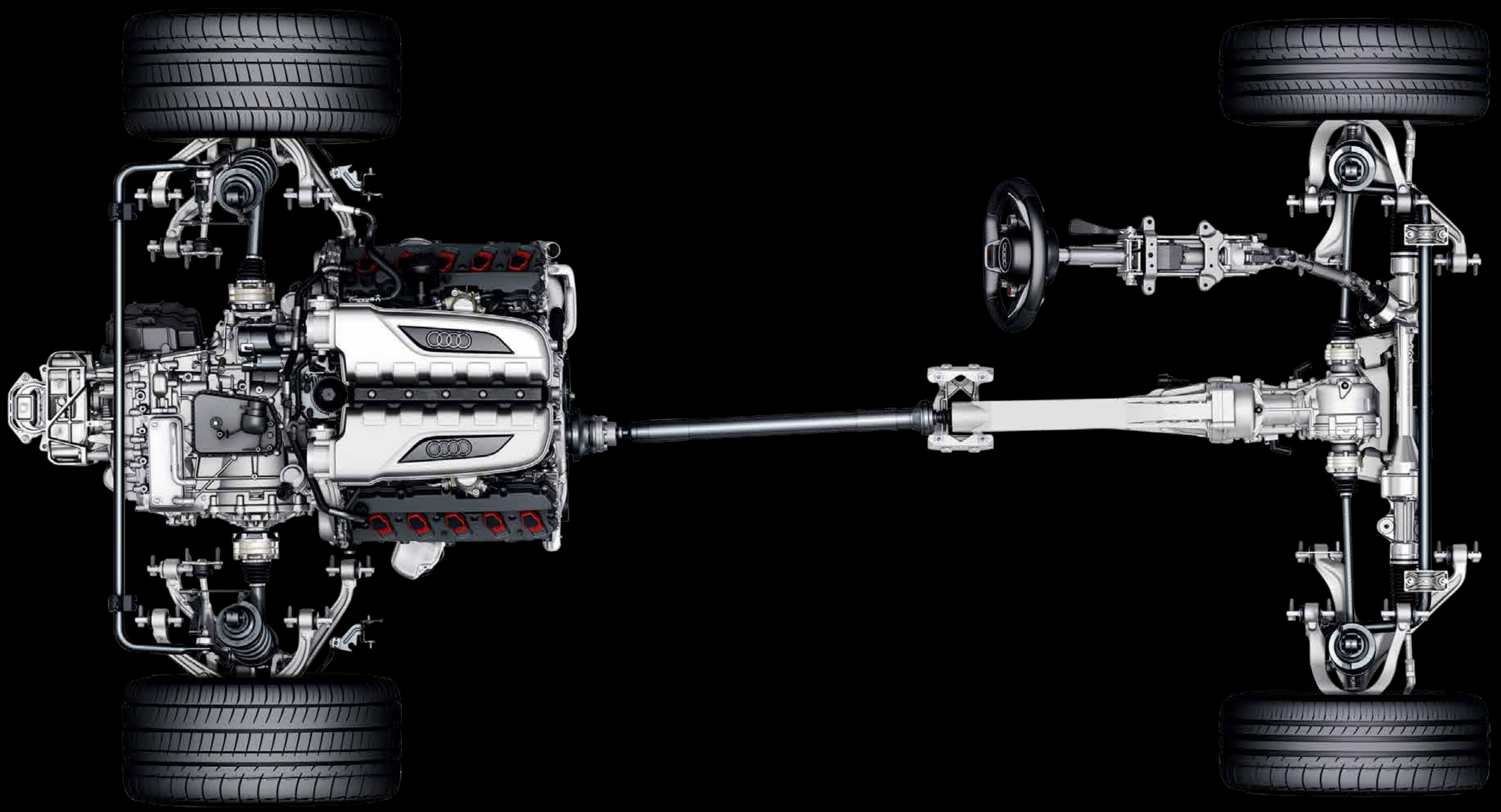



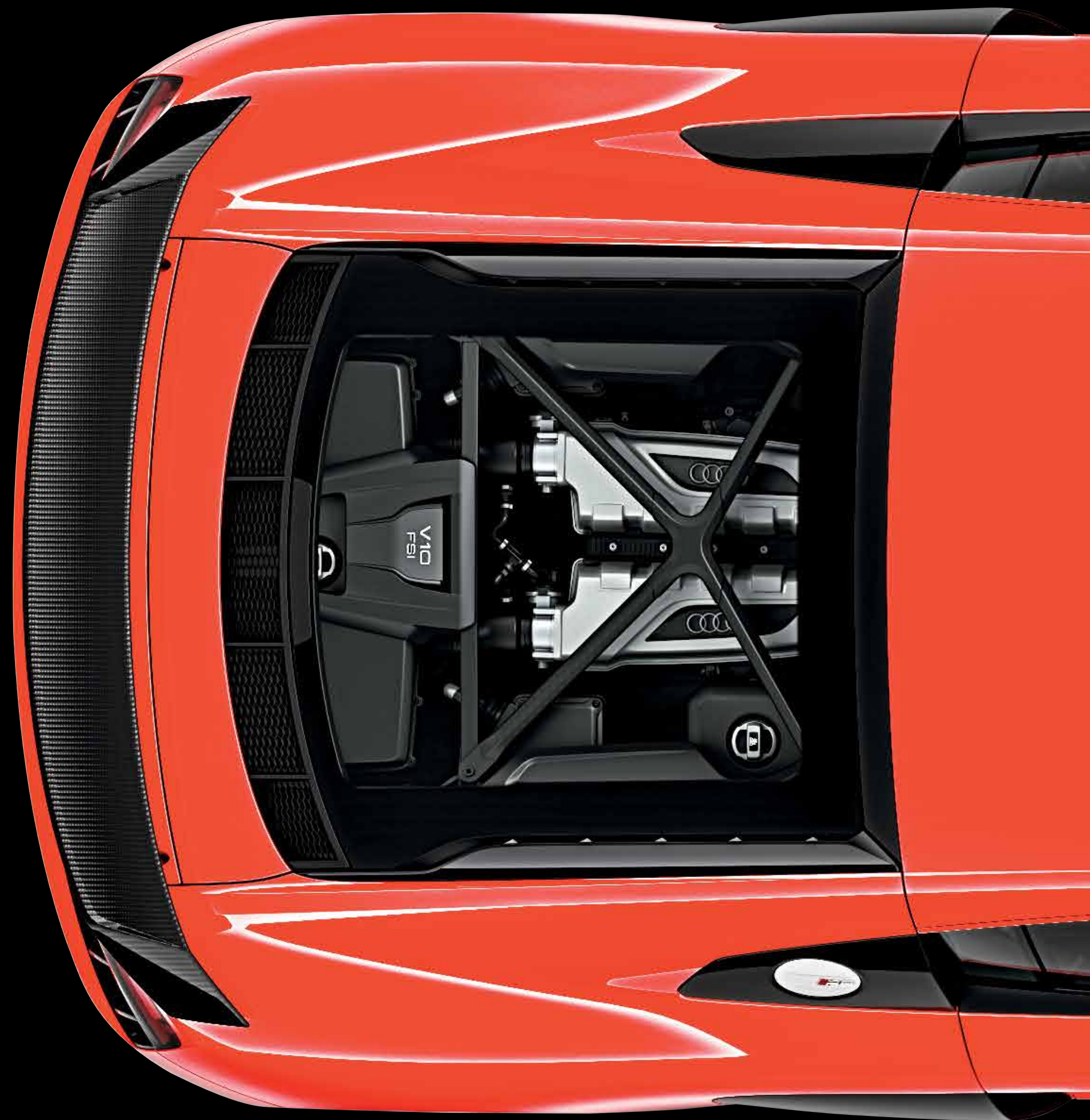

People work a lifetime to perfect something that takes a few seconds—or even a few hundredths of a second—off a 0–60 time. With the all-new R8, we see the culmination of a vision started by famed Audi engineer Jörg Bensinger, the mastermind behind the design and development of quattro® all-wheel drive. Working off the concept he helped put into production, we've further honed its capabilities so now, it emulates the power characteristics of a rear-wheel drive vehicle, but has the unique ability to send up to 100% of its available torque to the front axle when driving conditions dictate it. It's a new wrinkle that incorporates the electronically-controlled hydraulic multi-plate clutch, the addition of torque vectoring and quattro integration within the Audi drive select system. The result of fine-tuning already visionary engineering? It makes your success fly by and the achievement of a lifetime ever more impressive. _____

*THIS IS HOW PRECISION
ENGINEERING REVEALS
ITSELF TO YOUR SOUL.*



*THIS IS HOW PRECISION
ENGINEERING REVEALS
ITSELF TO YOUR SOUL.*



 Sheet aluminum



European model shown.

In a sense, this is design stripped to its elemental essence. We strip away weight to hone a strong, substructural chassis that relies on aluminum, carbon and other innovations to carry the performance of a supercar. This ASF® multi-material space frame is a new application of the iconic ASF chassis. It lessens the static and dynamic weight of the vehicle, and increases rigidity by 40 percent for a more dynamic drive. It's structural engineering that helps build soul. —

*NEARLY HALF OF OUR TRACK
RECORD IS ROADWORTHY.*



European model shown.

NEARLY HALF OF OUR TRACK RECORD IS ROADWORTHY.

■ Audi racing heritage and DNA

We always think about how we can add track performance technology to the road. In the case of the Audi R8, you can also envision the road car winning on the track. That's because the Audi R8 LMS—our winning GT3 racecar at the *Rolex 24 at Daytona*, developed at the same time—shares around 50% of its component parts with its road-legal sibling. How the collaboration between track-shredding race engineering and thrilling sport driving impacts the joy of your commute is best left to your imagination—until you drive there.¹ —



[Search R8 Inventory](#) ↗

European model shown.

¹ Always obey all speed and traffic laws.

*FAST DOESN'T
COME QUICKLY.*



*FAST DOESN'T
COME QUICKLY.*



Age

Craft

Refined



Age before beauty.

Audi vehicles are made by committed craftsmen, but, like the R8 itself, there's a best among the best. That means it takes years, specialized training and an elevated sense of patience before a select few can join the R8 line. It's a painstaking job that's not for everyone. And that's the point.



Aggressively refined.

Our facility, an exclusive logistics and production facility is in Heilbronn, Germany, about 150 miles from the main plant in Ingolstadt. Here craftsmen and machines work unhurriedly to produce the work of art that meets the road. They have to meet their orders, of course, but more than that, they have to meet exacting standards of what an R8 should be. —



▀ Craft is a lifelong pursuit.

The body of an R8 is a complicated, involved skeleton. By employing innovations like a Resin Transfer Molding process, it allows for enhanced design flexibility for carbon fiber construction. But it also features a two-stage manufacturing process that takes into account the different thermal expansions of aluminum, carbon fiber and resin. Without these time-consuming, precise processes, the craftsmanship you find inside the R8 wouldn't be so timeless. —

*THERE'S A TIME WHEN THE
MOST THRILLING THING
YOU CAN HEAR IS, "IT'S ALL
DOWNHILL FROM NOW ON."*

Find A Local Dealer ↗

*THERE'S A TIME WHEN THE
MOST THRILLING THING
YOU CAN HEAR IS, "IT'S ALL
DOWNHILL FROM NOW ON."*

Find A Local Dealer ↗



V10
1500

*CORNERING PASSION
IS ONE WAY TO DEFINE
PERFORMANCE.*

With the mid-engine design, the handling of the R8 is further enhanced by a chassis that is equally suitable for a day on the track or the commute home—thanks to balance provided by the mid-engine placement as well as the traction and agility afforded by quattro® all-wheel drive. This is made for thrilling turns and balanced power! It is performance reinforced and honed by brilliant engineering. [_____](#)

*POWER IS CENTRAL
TO OUR POINT.*

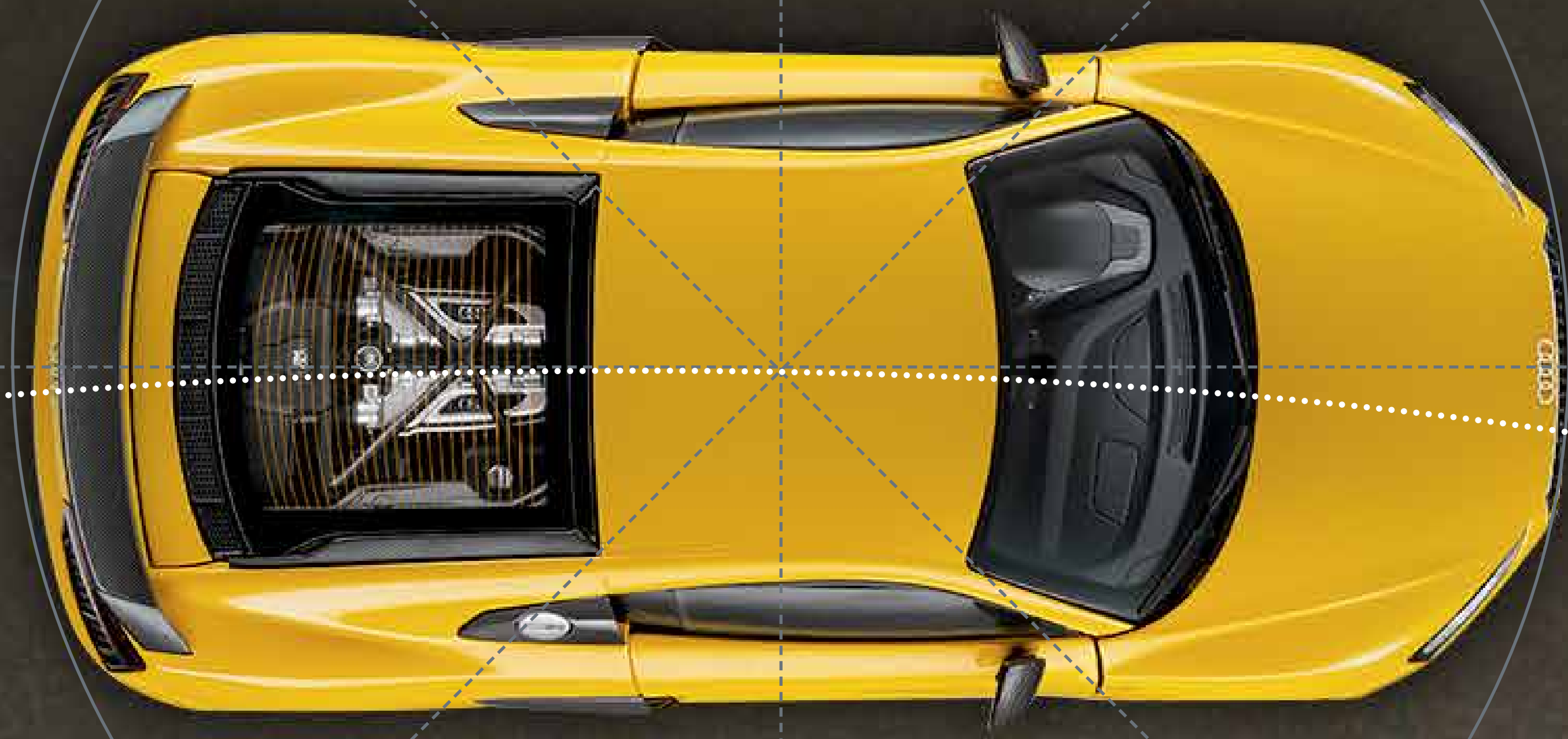

POWER IS CENTRAL TO OUR POINT.

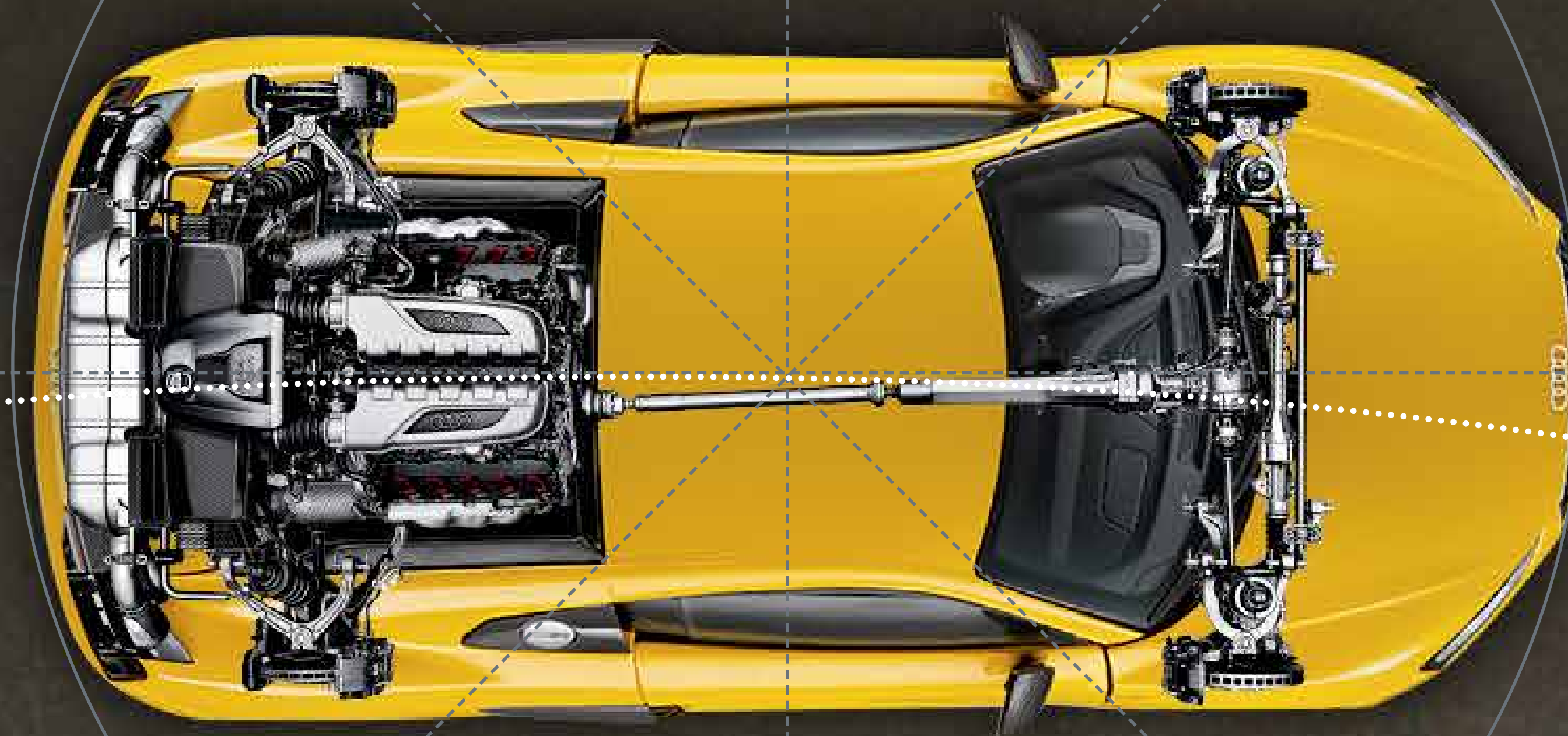

58%

42%

Extreme, despite its balance.

The R8 reaches the pinnacle of performance. This is true, at least in part, because of Audi's mid-engine drivetrain layout. First found in motorsports (like the legendary Auto Union Silver Arrows which won racing awards for the four rings in the 1930s), the engine placement provides vehicle balance through its optimized center of gravity and dynamic weight transfer characteristics.

[Schedule a Test Drive ↗](#)



*THIS KIND OF PERFORMANCE
IS AN ASPIRATIONAL GOAL.*



*THIS KIND OF PERFORMANCE
IS AN ASPIRATIONAL GOAL.*



Build your 2017 R8 [↗](#)

540
horsepower

R8 V10

The naturally aspirated V10 engine more than holds its own, with an astonishing 540 hp and 398 lb-ft of torque that hits the redline at 8,700 rpm.¹ This is absolute power for absolute thrill. [—](#)

610
horsepower

R8 V10 plus

Churning out 610 hp with 413 lb-ft of torque, the R8 V10 plus can reach 0-60 in 3.2 seconds.¹ A blistering time that accelerates your heart rate probably even faster than the vehicle. [—](#)

¹ Always obey all speed and traffic laws.



A ROAR PRECEDING THE SILENCE OF DROPPED JAWS.

This new exhaust system with integrated twin-trapezoidal exhaust outlets on both the V10 and V10 plus, features variable exhaust flaps that, once opened, provide an electrifying exhaust note. That accompanying roar is where the balance of engine, powertrain and exhaust acoustics meet. R8 V10 plus models include a Sport exhaust system with Black finishers and manual audible control that can be accessed through the Sport exhaust satellite button on the steering wheel.

R8



LISTEN

A ROAR PRECEDING THE SILENCE OF DROPPED JAWS.

This new exhaust system with integrated twin-trapezoidal exhaust outlets on both the V10 and V10 plus, features variable exhaust flaps that, once opened, provide an electrifying exhaust note. That accompanying roar is where the balance of engine, powertrain and exhaust acoustics meet. R8 V10 plus models include a Sport exhaust system with Black finishers and manual audible control that can be accessed through the Sport exhaust satellite button on the steering wheel.

R8



LISTEN

INJECTING A POWERFUL NEW IDEA INTO THE STORY.

The fuel injection system in the R8 combines the benefits of indirect (intake runner/upstream of the intake valve) and direct injection (directly in the cylinder). This new system uses an intelligent engine management control unit to help optimize fuel injection and distribution based on engine load. With these technologies, the fuel management of the R8 can utilize 100% indirect injection under reduced engine load and speed. As the engine speed and load increases, a ratio of 50:50 indirect/direct injection is used. Under strenuous engine loads, where the greatest power is required, a ratio of 15:85 is used to transform the energy contained in fuel into power, while helping cool the combustion chamber to prevent engine knock. —

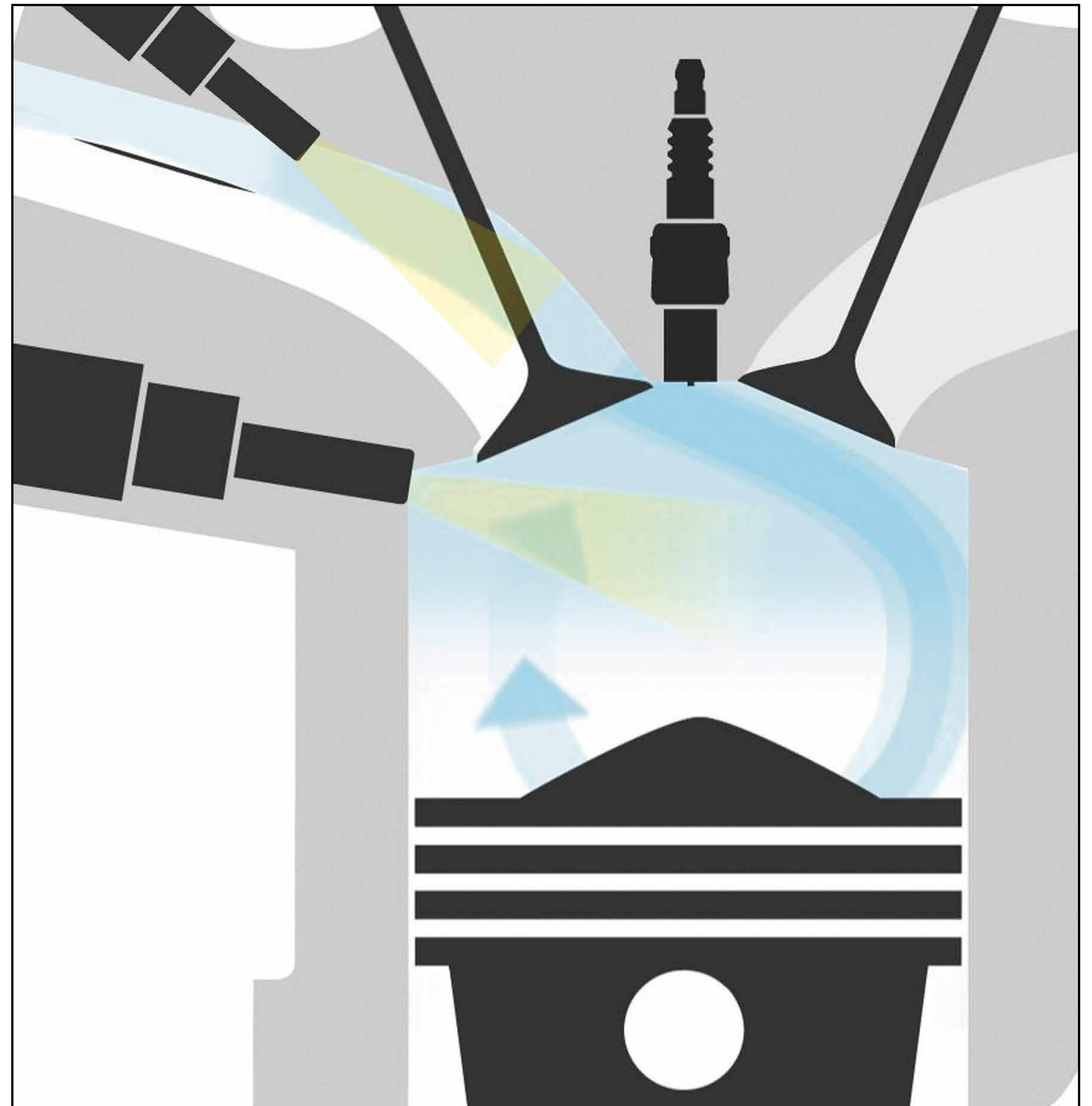

FULL PERFORMANCE. FULL POWER.

Swipe



V10
FSI

*FULL
CONSCIENCE.*



Road driving means that sometimes you have to stop. Everything else can stay the same now. That's when our cylinder on demand™ engine efficiency technology comes in handy. Sensors shut off fuel supply and the ignition system under certain driving and vehicle parameters. This management system can allow the new R8 to reduce the fuel use from all ten cylinders to just five, helping improve fuel efficiency when you don't—and can't—use the power.¹ —

¹ 14 city/22 highway mpg (2017 Audi R8 5.2-liter FSI® V10 engine with seven-speed S tronic® transmission and quattro® all-wheel drive). EPA estimates. Your mileage will vary and depends on several factors, including your driving habits and vehicle condition.

*HALF
POWER.*



Find A Local Dealer ↗

IT TAKES SOME ASSISTANCE TO ACHIEVE THIS KIND OF POWER.

Performance driving isn't about the engine alone. In the Audi R8, we couple raw power with sculpted performance by incorporating complementary technologies—quattro® all-wheel drive and our S tronic® dual-clutch transmission.¹

**S tronic® dual-clutch
transmission**

quattro® all-wheel drive

1. Always obey all speed and traffic laws



■ S tronic® dual-clutch transmission

The R8 V10 plus features a gear set uniquely suited for performance-oriented driving, with gears 3 through 7 having shorter ratios, providing closer shift patterns that allow for maximum power output. The V10 features an overdrive gear in 7th speed, which has a longer ratio that is particularly suited to low engine load and cruising engine speeds.

IT TAKES SOME ASSISTANCE TO ACHIEVE THIS KIND OF POWER.

Performance driving isn't about the engine alone. In the Audi R8, we couple raw power with sculpted performance by incorporating complementary technologies—quattro® all-wheel drive and our S tronic® dual-clutch transmission.¹

**S tronic® dual-clutch
transmission**

quattro® all-wheel drive

1. Always obey all speed and traffic laws

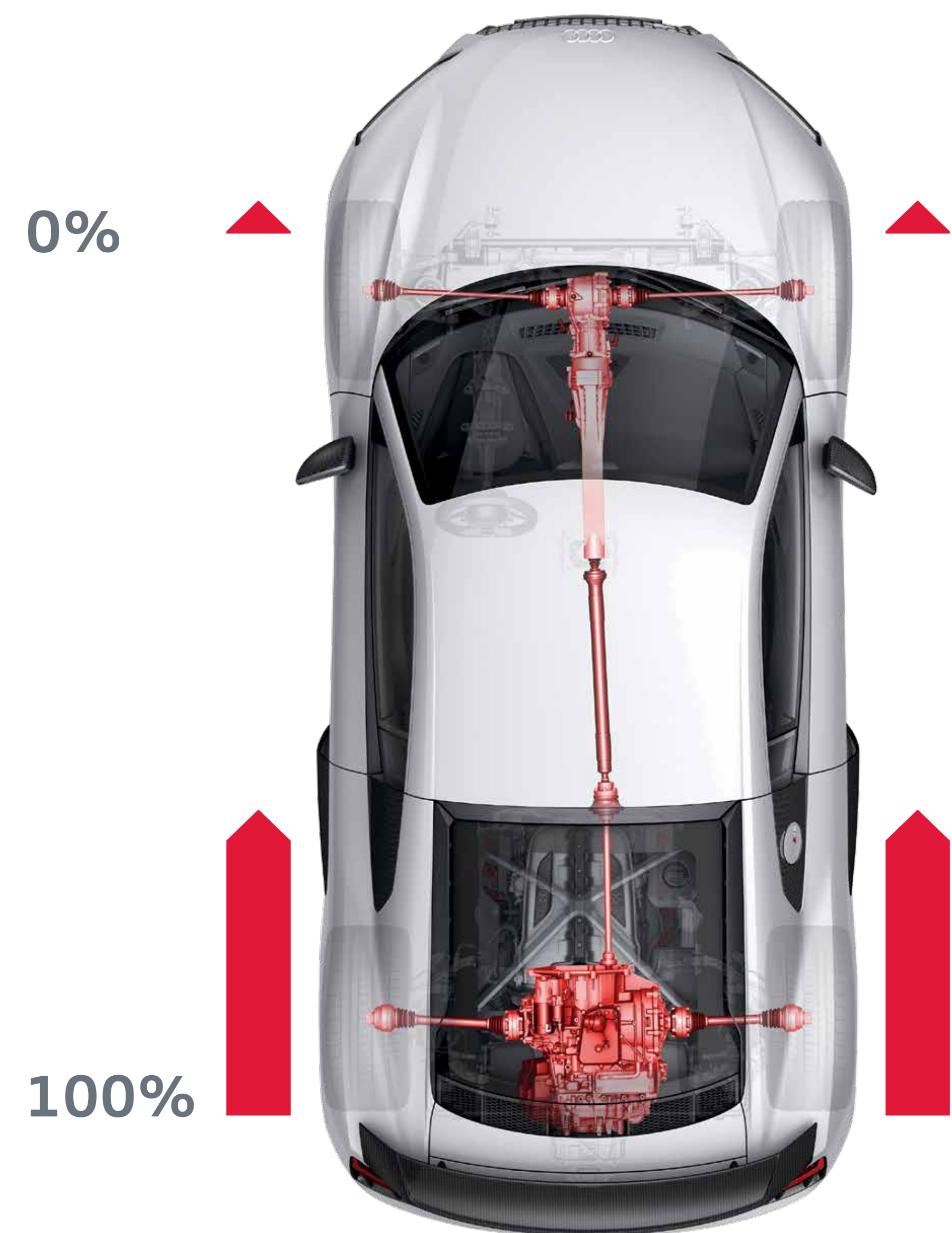

quattro® all-wheel drive

Nature finds a way. Engineering takes notes. Watching certain animals pivot and accelerate helped us develop a new application of quattro® all-wheel drive, for the all-new R8. With this new electronically controlled hydraulic multi-plate clutch, you have the performance advantages of a rear-wheel drive vehicle, but with the ability to send up to 100% of available torque to the front axle, depending on the driving situation. This is a seamless application of technology, the performance of torque vectoring and quattro® integration within the Audi drive select system.

IT TAKES SOME ASSISTANCE TO ACHIEVE THIS KIND OF POWER.

Performance driving isn't about the engine alone. In the Audi R8, we couple raw power with sculpted performance by incorporating complementary technologies—quattro® all-wheel drive and our S tronic® dual-clutch transmission.¹

**S tronic® dual-clutch
transmission**

quattro® all-wheel drive

1. Always obey all speed and traffic laws

25%



75%



quattro® all-wheel drive

Nature finds a way. Engineering takes notes. Watching certain animals pivot and accelerate helped us develop a new application of quattro® all-wheel drive, for the all-new R8. With this new electronically controlled hydraulic multi-plate clutch, you have the performance advantages of a rear-wheel drive vehicle, but with the ability to send up to 100% of available torque to the front axle, depending on the driving situation. This is a seamless application of technology, the performance of torque vectoring and quattro® integration within the Audi drive select system. —

IT TAKES SOME ASSISTANCE TO ACHIEVE THIS KIND OF POWER.

Performance driving isn't about the engine alone. In the Audi R8, we couple raw power with sculpted performance by incorporating complementary technologies—quattro® all-wheel drive and our S tronic® dual-clutch transmission.¹

**S tronic® dual-clutch
transmission**

quattro® all-wheel drive

1. Always obey all speed and traffic laws

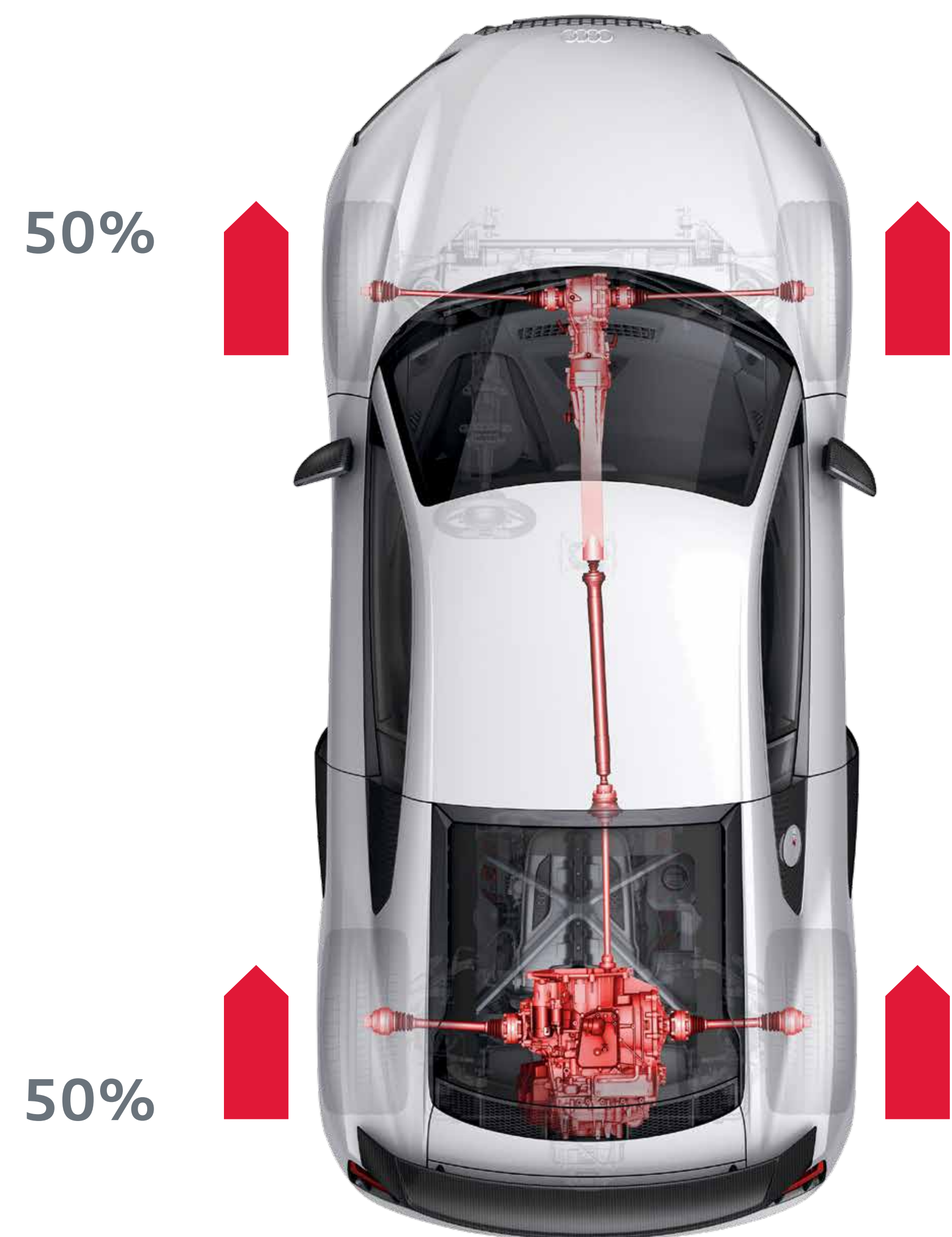

quattro® all-wheel drive

Nature finds a way. Engineering takes notes. Watching certain animals pivot and accelerate helped us develop a new application of quattro® all-wheel drive, for the all-new R8. With this new electronically controlled hydraulic multi-plate clutch, you have the performance advantages of a rear-wheel drive vehicle, but with the ability to send up to 100% of available torque to the front axle, depending on the driving situation. This is a seamless application of technology, the performance of torque vectoring and quattro® integration within the Audi drive select system.

IT TAKES SOME ASSISTANCE TO ACHIEVE THIS KIND OF POWER.

Performance driving isn't about the engine alone. In the Audi R8, we couple raw power with sculpted performance by incorporating complementary technologies—quattro® all-wheel drive and our S tronic® dual-clutch transmission.¹

**S tronic® dual-clutch
transmission**

quattro® all-wheel drive

1. Always obey all speed and traffic laws

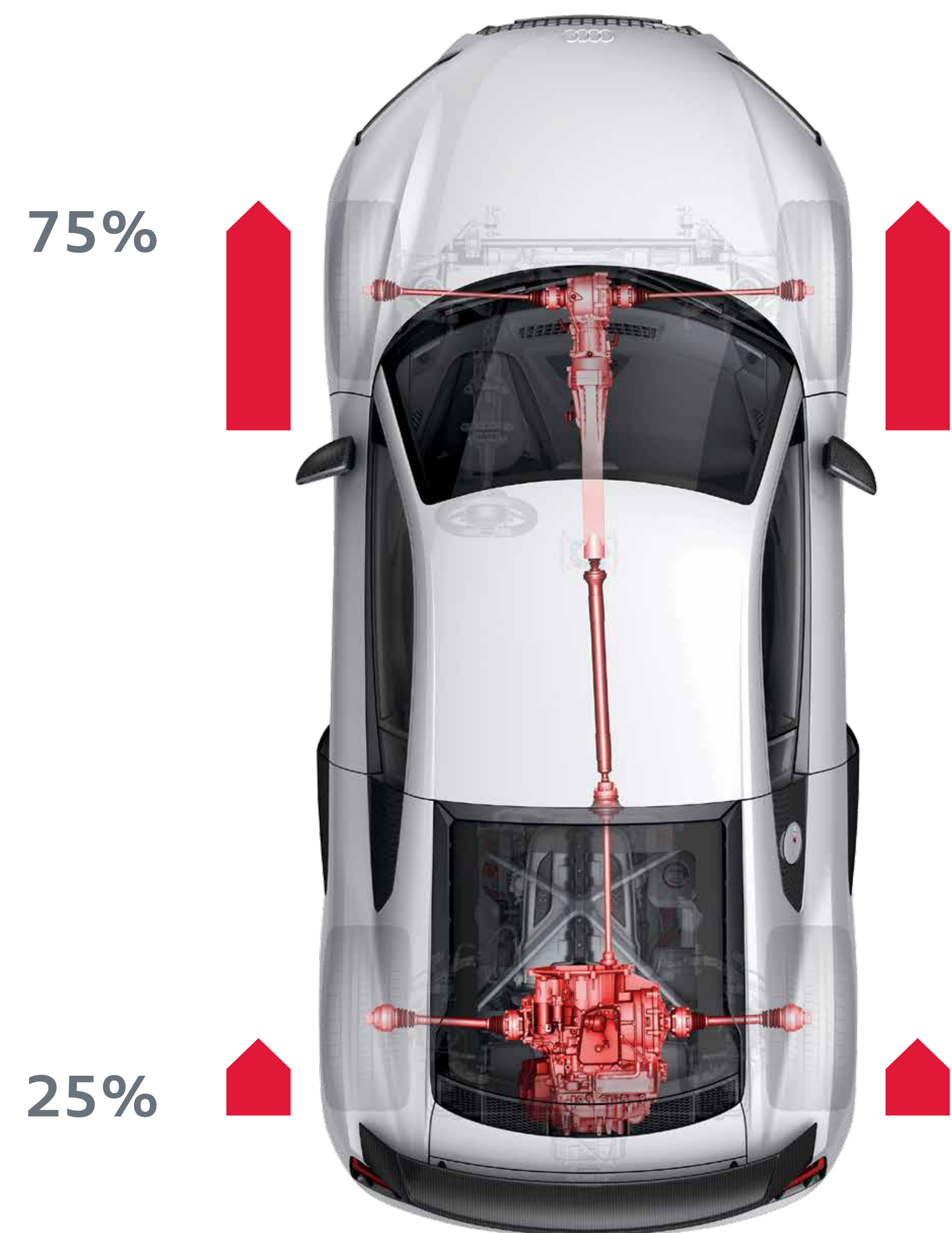

quattro® all-wheel drive

Nature finds a way. Engineering takes notes. Watching certain animals pivot and accelerate helped us develop a new application of quattro® all-wheel drive, for the all-new R8. With this new electronically controlled hydraulic multi-plate clutch, you have the performance advantages of a rear-wheel drive vehicle, but with the ability to send up to 100% of available torque to the front axle, depending on the driving situation. This is a seamless application of technology, the performance of torque vectoring and quattro® integration within the Audi drive select system.

IT TAKES SOME ASSISTANCE TO ACHIEVE THIS KIND OF POWER.

Performance driving isn't about the engine alone. In the Audi R8, we couple raw power with sculpted performance by incorporating complementary technologies—quattro® all-wheel drive and our S tronic® dual-clutch transmission.¹

**S tronic® dual-clutch
transmission**

quattro® all-wheel drive

1. Always obey all speed and traffic laws

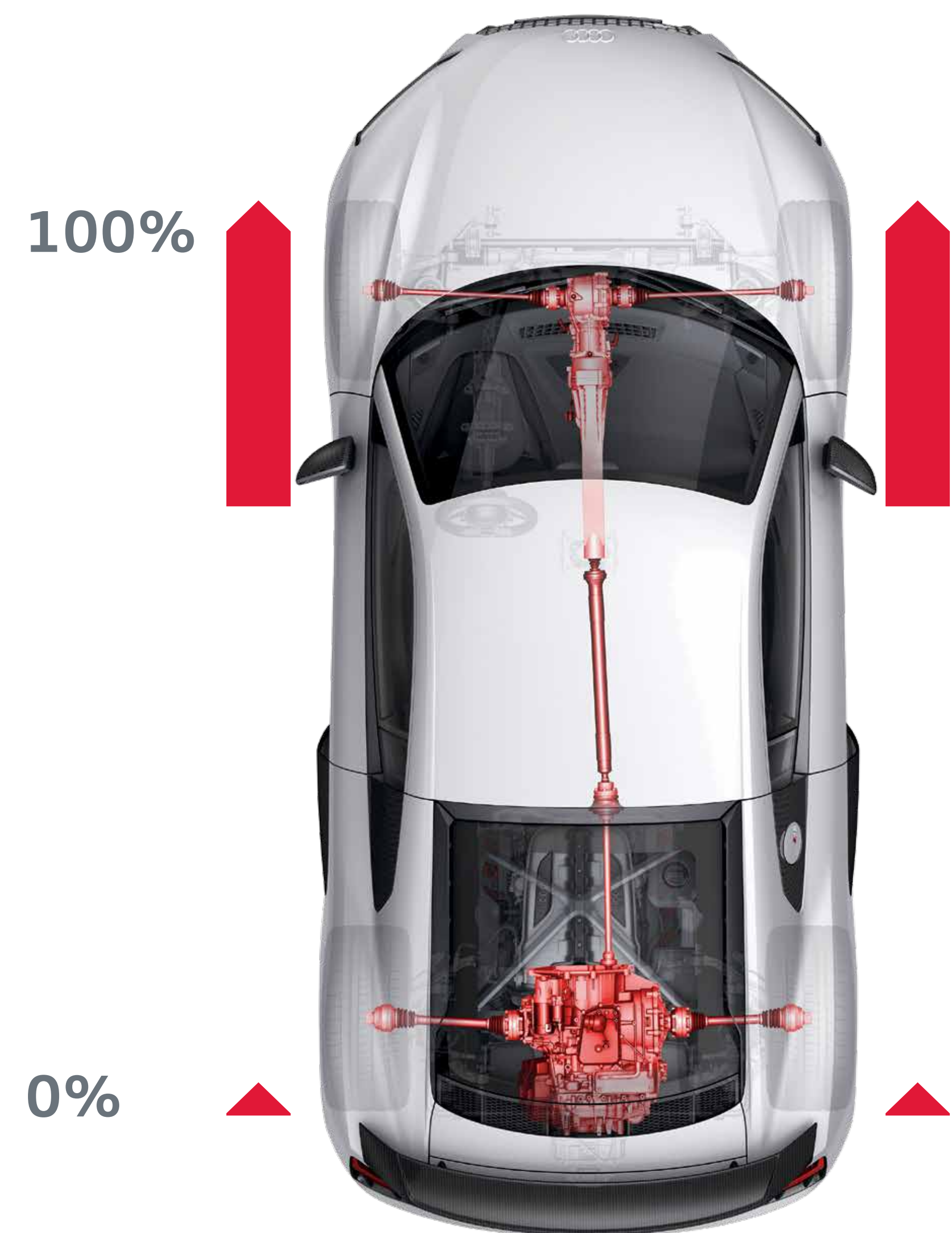

quattro® all-wheel drive

Nature finds a way. Engineering takes notes. Watching certain animals pivot and accelerate helped us develop a new application of quattro® all-wheel drive, for the all-new R8. With this new electronically controlled hydraulic multi-plate clutch, you have the performance advantages of a rear-wheel drive vehicle, but with the ability to send up to 100% of available torque to the front axle, depending on the driving situation. This is a seamless application of technology, the performance of torque vectoring and quattro® integration within the Audi drive select system.

*YOU AREN'T WRONG.
THE RIDE IS MAGNETIC.*

Comfort

Dynamic

*YOU AREN'T WRONG.
THE RIDE IS MAGNETIC.*

Comfort

Dynamic

AUDI MAGNETIC RIDE.



Swipe

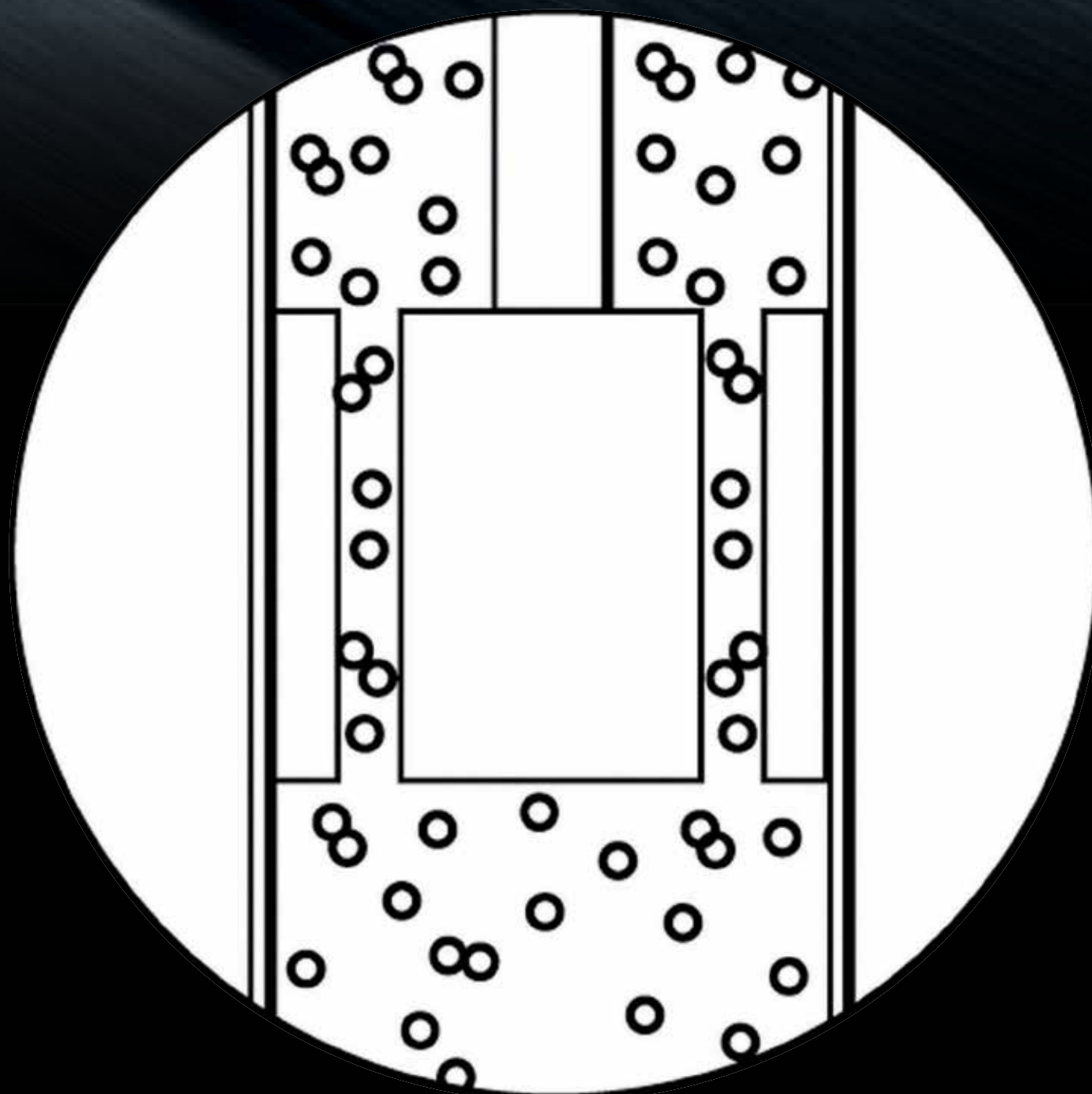

Comfort mode

Standard on the R8 V10, Audi magnetic ride uses a special oil that contains tiny magnetic particles to help adjust the firmness of the dampers through an electrically-charged magnetic field within the shock absorbers. In Comfort mode, the road can feel a little more relaxing, allowing for more forgiving handling and cushioned shock absorption; perfect for long drives. —

Dynamic mode

In Dynamic mode, the tension is increased to help enable a more rigid ride for sharper handling. The R8 is connected to an elevated sense of thrill. (Note: Audi R8 V10 plus models are fitted with a fixed sport suspension system). —

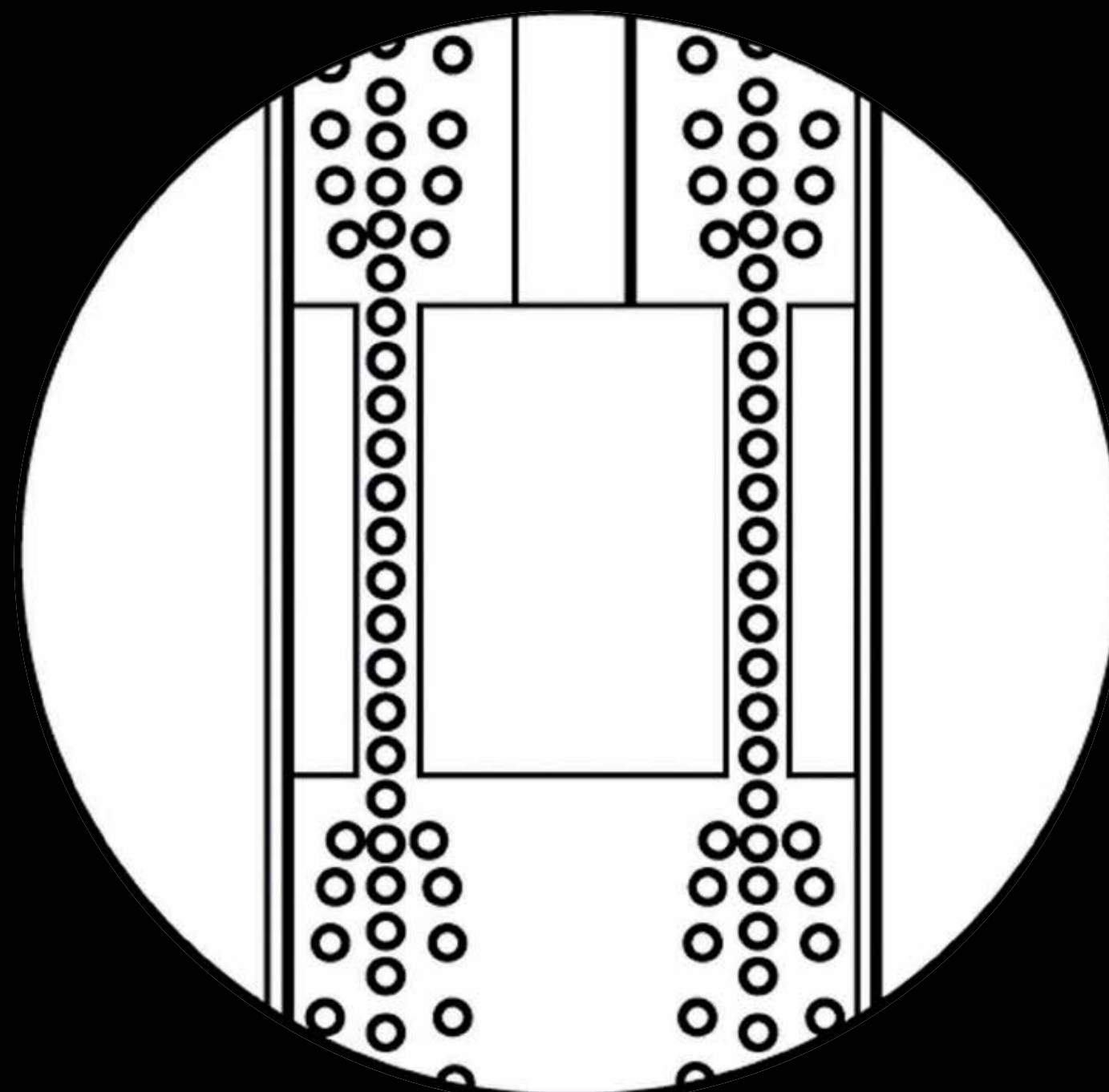

Always obey all speed and traffic laws.



*OUR 0-60 GRABS
YOUR ATTENTION.*





*60-0 MIGHT BE
THE REAL STORY.*







PULL ^

PULL ^



Wave-cut design brakes

The wave-cut brake is standard on R8 V10 models and rotors help decrease up to 6.61 lbs from traditional round rotors, decreasing unsprung weight, help improve acceleration as well as deceleration. A two-piece rotor construction, cross drilling and ventilation also helps manage heat dissipation as well as overall weight, improving performance on multiple levels. You can also choose red-painted brake calipers as an option. —





Wave-cut design brakes

The wave-cut brake is standard on R8 V10 models and rotors help decrease up to 6.61 lbs from traditional round rotors, decreasing unsprung weight, help improve acceleration as well as deceleration. A two-piece rotor construction, cross drilling and ventilation also helps manage heat dissipation as well as overall weight, improving performance on multiple levels. You can also choose red-painted brake calipers as an option. —



Audi ceramic brakes

Offered as an option on R8 V10 and as standard on V10 plus models, carbon ceramic brake discs are even lighter than our metal models with up to 8.82 lbs saved in contrast to traditional cast iron rotors. The design offers increased resistance to fade. Calipers are finished in an Anthracite Gray and feature the Audi ceramic logo. —



OUR CENTRAL FOCUS IS ON THE DRIVER'S SIDE.

The interior of the R8 is defined by the Monoposto design, a large arc that recalls the shape of a racecar driver's cockpit. This makes for a driver-centric cockpit that offers both an intuitive layout and easy instrument reach, all developed with performance driving in mind. —



[Schedule a Test Drive ↗](#)





European model shown.



quattro

22.5
AUTO

OFF

18.5

REAR

GETTING FROM A TO Z IS AS EASY AS WRITING A OR Z.

Integrated with the Audi virtual cockpit, MMI® touch with handwriting recognition allows you to access media and navigation with a few strokes of your fingertips. Get the song, the contact or directions delivered directly to your Audi virtual cockpit.¹

MMI® touch

Available for the first time on the Audi R8, MMI® navigation plus features MMI® touch with handwriting recognition technology—enabling users to simply ‘write’ their entry on a touchpad rather than selecting individual letters, as used in traditional systems.



¹ Always pay careful attention to the road, and do not drive while distracted. Not all features available on all operating systems. Standard text and data usage rates apply. These features require compatible device, operating system, and mobile apps. See mobile device and app providers for terms and privacy.

GETTING FROM A TO Z IS AS EASY AS WRITING A OR Z.

Integrated with the Audi virtual cockpit, MMI® touch with handwriting recognition allows you to access media and navigation with a few strokes of your fingertips. Get the song, the contact or directions delivered directly to your Audi virtual cockpit.¹

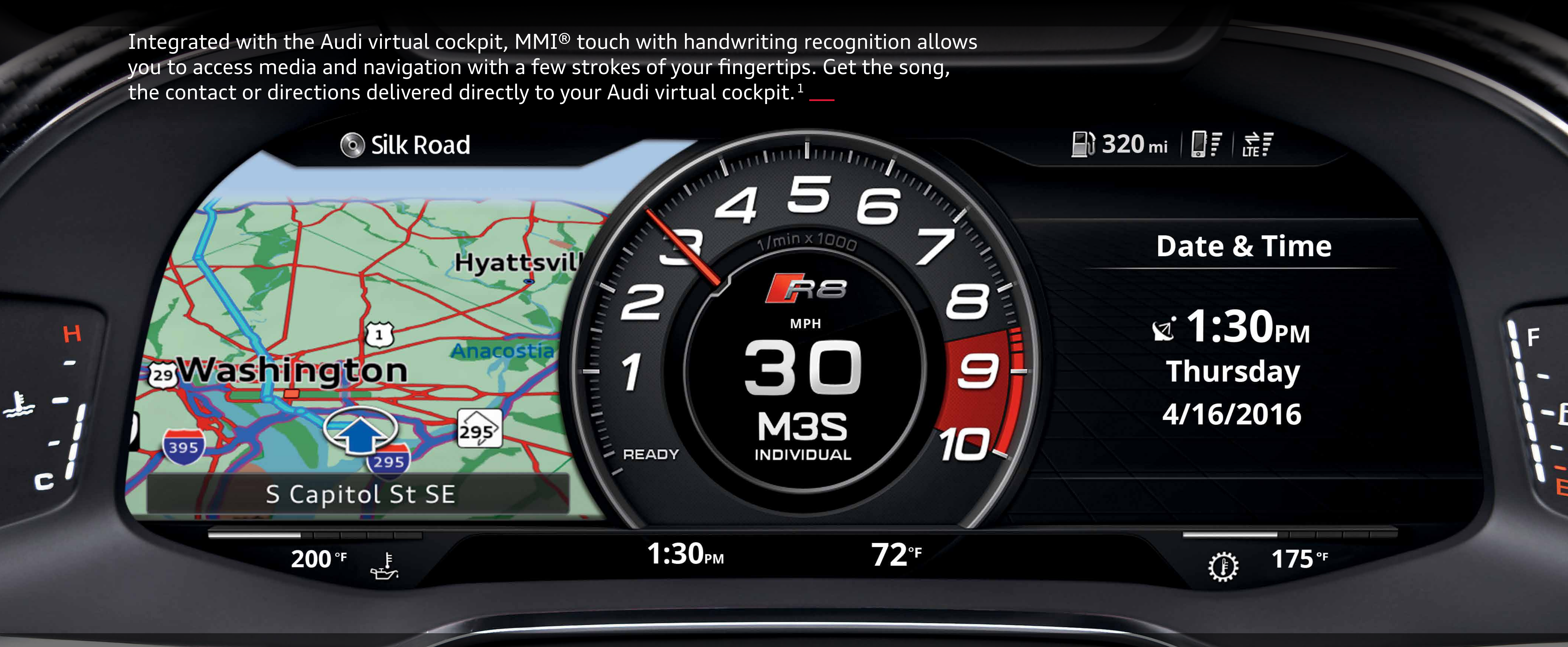

MMI® touch

Available for the first time on the Audi R8, MMI® navigation plus features MMI® touch with handwriting recognition technology—enabling users to simply ‘write’ their entry on a touchpad rather than selecting individual letters, as used in traditional systems.

¹ Always pay careful attention to the road, and do not drive while distracted. Not all features available on all operating systems. Standard text and data usage rates apply. These features require compatible device, operating system, and mobile apps. See mobile device and app providers for terms and privacy.

ANOTHER VENUE FOR THUNDEROUS PERFORMANCE.

Propulsive performances get a powerful boost from sound. Whether it's the sound of your engine revving or your favorite songs from your audio system, the sounds in your Audi R8 are anything but noise—helping you feel the drive in both intense and visceral ways. —

BANG & OLUFSEN



ANOTHER VENUE FOR THUNDEROUS PERFORMANCE.

Propulsive performances get a powerful boost from sound. Whether it's the sound of your engine revving or your favorite songs from your audio system, the sounds in your Audi R8 are anything but noise—helping you feel the drive in both intense and visceral ways. —

BANG & OLUFSEN

■ Bang and Olufsen® Sound System

Designed to integrate specifically to the contours and the cabin of the all-new Audi R8, the Bang & Olufsen® Sound System offers cutting-edge audio technology as standard equipment on the R8 V10 and is available on the V10 plus models. The system features 13 active speakers—along with a 13-channel amplifier, including a subwoofer, which has been strategically placed in the chamber of the front wheel well—capable of producing 550 watts of pure, crisp sound. All packaged in a seamlessly stylish acoustic experience for your R8. —



WE DON'T TAKE GREAT DESIGN SITTING DOWN.

Even though the all-new Audi R8 is a study in acceleration, our commitment to craft helped inspire a chair design that was stylish enough to make it into art shows, while innovative enough to influence the seat design of the R8. If we can improve upon a 5000 year-old design, imagine what we can do for a supercar. [_____](#)



WE DON'T TAKE GREAT DESIGN SITTING DOWN.

Even though the all-new Audi R8 is a study in acceleration, our commitment to craft helped inspire a chair design that was stylish enough to make it into art shows, while innovative enough to influence the seat design of the R8. If we can improve upon a 5000 year-old design, imagine what we can do for a supercar. [—](#)



*DESIGN THAT BLURS
LINES HAS TO BEGIN
WITH STRIKING ONES.*

Swipe >



The look of the R8 is unmistakable in intent. This is the look of performance. The cockpit is forward; the flowing roofline is reminiscent of nothing but a racing silhouette. In every flowing line, there is proof how it is blurred, but never unrecognizable when it is driving by. —

Build your 2017 R8 ↗

DESIGN THAT BLURS LINES HAS TO BEGIN WITH STRIKING ONES.

The door handles are harmoniously integrated into the distinctive shadow created by the Audi R8 shoulder line.

A strong shoulder line is uninterrupted by the new two-piece design of the Audi sideblades.

Prominent wheel arches suggestive of the R18 LMP1 racecar.

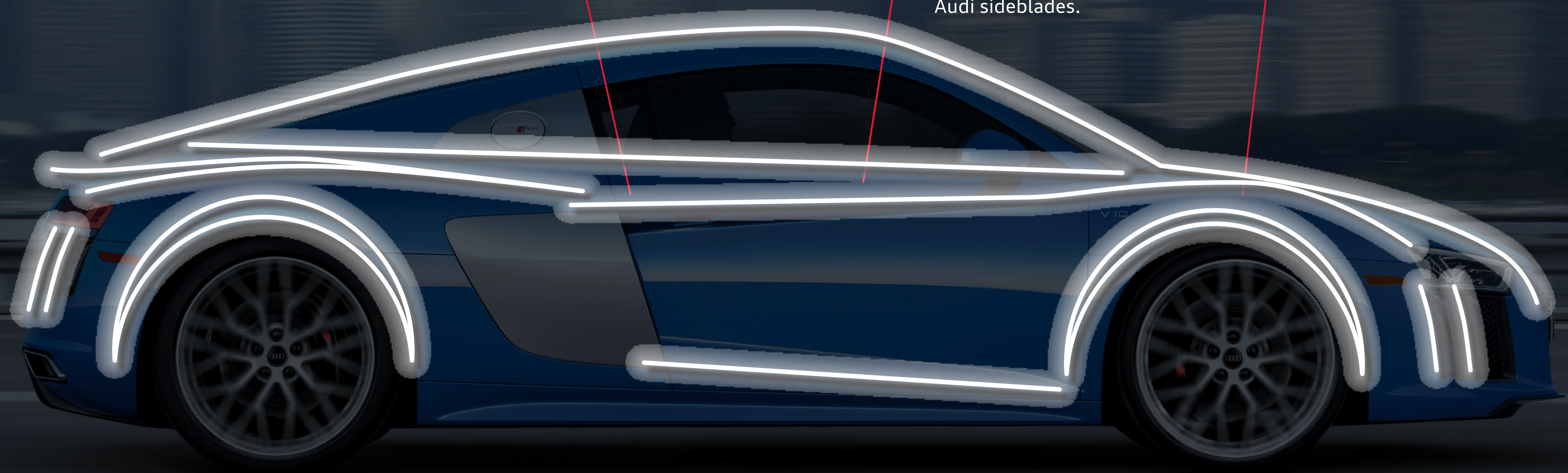

The look of the R8 is unmistakable in intent. This is the look of performance. The cockpit is forward; the flowing roofline is reminiscent of nothing but a racing silhouette. In every flowing line, there is proof how it is blurred, but never unrecognizable when it is driving by.

Build your 2017 R8 [↗](#)

Swipe >



Build your 2017 R8 ↗

Audi exclusive models shown.

The vertical design of the lower air inlets is reflected in the vertical daytime running light pattern.

Three-dimensional Singleframe® grille with honeycomb pattern gives a flatter, wider appearance than ever before and alludes to Audi Sport® DNA.

The rear LED taillights also reflect the vertical design cues of the air outlets below.



Build your 2017 R8 [↗](#)

RESISTANCE IS FUTILE.

Let it all pass you by. Not technology or innovation or power. But the air itself. For acceleration and top track speed, aerodynamic design is a key requirement. The aerodynamics of the R8 prove that resistance and air resistance is futile. With our advanced design, the balance between aerodynamic drag and downforce lets you power through nearly undisturbed.¹ _____

¹ Always obey all speed and traffic laws.

RESISTANCE IS FUTILE.

Let it all pass you by. Not technology or innovation or power. But the air itself. For acceleration and top track speed, aerodynamic design is a key requirement. The aerodynamics of the R8 prove that resistance and air resistance is futile. With our advanced design, the balance between aerodynamic drag and downforce lets you power through nearly undisturbed.¹ 



Find A Local Dealer 

¹ Always obey all speed and traffic laws.



Front air vents

Because of our design, we have a lower drag co-efficient compared with many other supercars. In addition to our low-slung design, our front air vents serve as a funnel to the front side mount radiators. —



Sideblade air inlets

Air is further shunted aside via Audi sideblade air inlets, which, along with feeding air to the rear engine, give a signature look to functionality. 



■ Rear air vents

Without these helping to dissipate heat for the engine, the front and sideblade air vents wouldn't be as effective. Air passes through as well as over and around the R8, which can reduce the drag co-efficient to .34 when the spoiler on the R8 V10 is retracted. —

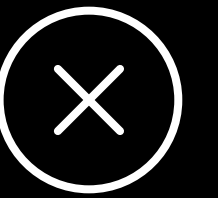

BEING KEPT DOWN CAN BE A GOOD THING.

It's not just about letting air flow past, it's also about downforce helping to keep in in better control on the road. On the R8, underbody features like drag reduction panels help ensure the underbody is smooth. These panels also contain NACA ports allowing additional air to be channeled through the engine bay or to other critical drivetrain components without helping to avoid a significant increase in drag. —



THRILL-SEEKING COMFORT.



We want you engaged and not too comfortable. That's why there's an art to developing the right kind of seat for R8 owners. They have to support, yet have the necessary firmness so you really feel the ride. [---](#)

[Search R8 Inventory ↗](#)

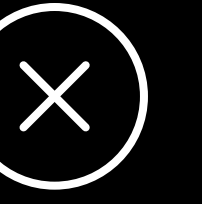

THRILL SEEKING COMFORT.



■ Sport seat

Our sport seat, standard on the V10 and available on the V10 plus, is precisely balanced between sport and luxury. Through the use of ergonomically contoured bolsters, we help you settle into your cockpit. With our 18-way power seats, we help you find the perfect position. But we go further—with integrated head restraints and pronounced seat side and seat bottom bolsters designed with pneumatic articulation and power leg extension to give both the driver and the passenger the kind of adaptive support needed for the comfort of thrill seeking.

The sport seat comes standard with Fine Nappa leather with four stunning color options—Black, Rotor Gray, Express Red or Vermont Brown; each available with iconic diamond stitching. Contrast stitching with or without diamond center inserts can be combined only with certain color combinations and is available in four colors: Black with Silver, Express Red, Ara Blue or Vegas Yellow.



■ Racing shell seat

Our racing shell seat was expressly designed for track conditions. Offering even more lateral support than our sport seat and contoured seat styling, this evokes a racing atmosphere in the cockpit. This is a narrow contoured seat without backrest angle adjustment, covered in Fine Nappa leather and embossed with the R8 logo. This seat is only for the V10 plus, where it comes standard.

We want you to feel the thrill of driving. That's why there's an art to developing the right kind of seat support, yet have the necessary firmness so you really feel the thrill.

[Search R8 Inventory](#) ↗

THRILL-SEEKING COMFORT.

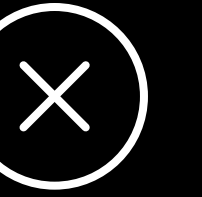

Racing shifter

Ergonomically shaped for easy and comfortable grip, the new racing inspired shifter represents an evolution of our shifting design, to complement our dynamic S tronic® transmission and shift-by-wire performance. [___](#)

We want you engaged and not too comfortable. That's why there's an art to developing the right kind of seat for R8 owners. They have to support, yet have the necessary firmness so you really feel the ride. [___](#)

[Search R8 Inventory](#) 

THRILL-SEEKING COMFORT.

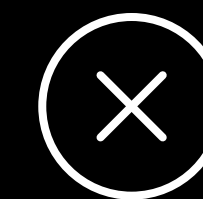

Climate controls

Three-dimensional climate control knobs mirror the styling of air intakes, further alluding to the motorsport-inspired design. These turn-and-push knobs offer precise control of temperature for your climate control system. [___](#)

We want you engaged and not too comfortable. That's why there's an art to developing the right kind of seat for R8 owners. They have to support, yet have the necessary firmness so you really feel the ride. [___](#)

[Search R8 Inventory](#) ↗

Audi R8 Colors



Dynamite Red

Shown with Ice Silver Audi sideblades

[Search R8 Inventory ↗](#)

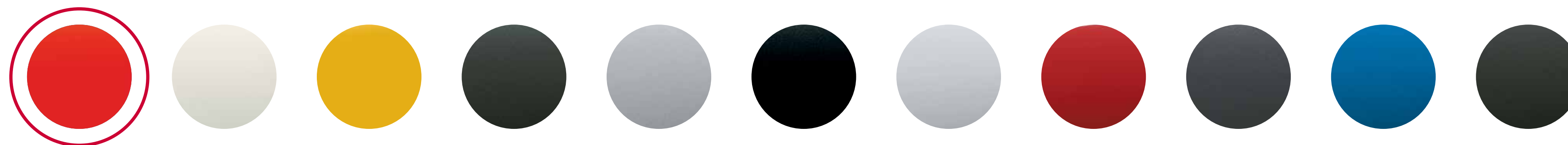

Exterior colors, interior colors, wheels and decorative inlay options will vary based on model and trim level combination and may increase price. See your dealer for details.

Audi R8 Colors



Ibis White

Shown with Ice Silver Audi sideblades

[Search R8 Inventory ↗](#)

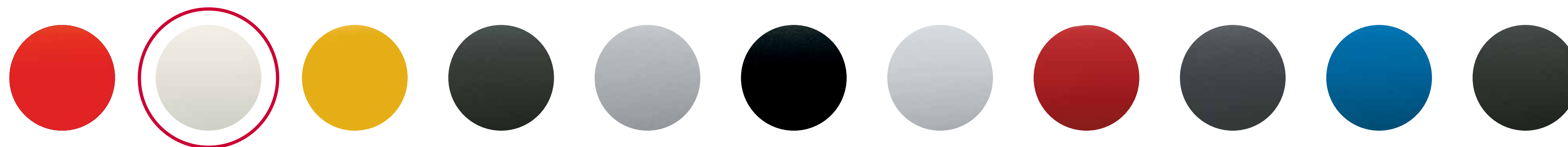

Exterior colors, interior colors, wheels and decorative inlay options will vary based on model and trim level combination and may increase price. See your dealer for details.

Audi R8 Colors



Vegas Yellow

Shown with Ice Silver Audi sideblades

[Search R8 Inventory ↗](#)

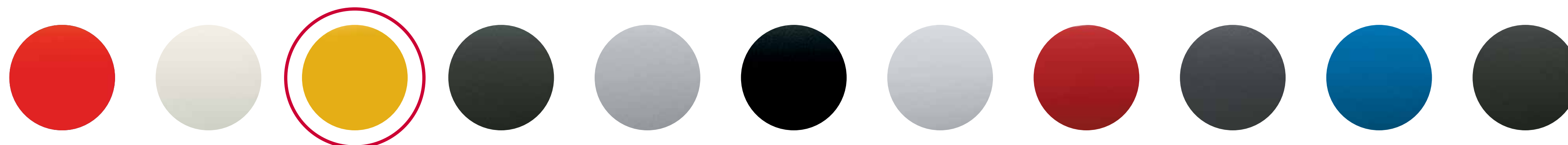

Exterior colors, interior colors, wheels and decorative inlay options will vary based on model and trim level combination and may increase price. See your dealer for details.

Audi R8 Colors



Camouflage Green metallic

Shown with Ice Silver Audi sideblades

[Search R8 Inventory ↗](#)

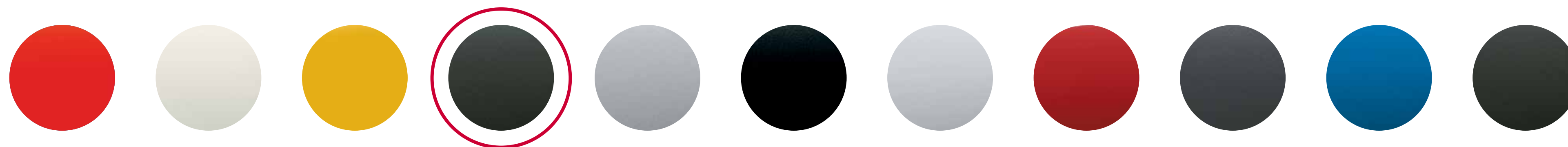

Exterior colors, interior colors, wheels and decorative inlay options will vary based on model and trim level combination and may increase price. See your dealer for details.

Audi R8 Colors



Florett Silver metallic

Shown with Ice Silver Audi sideblades

[Search R8 Inventory ↗](#)

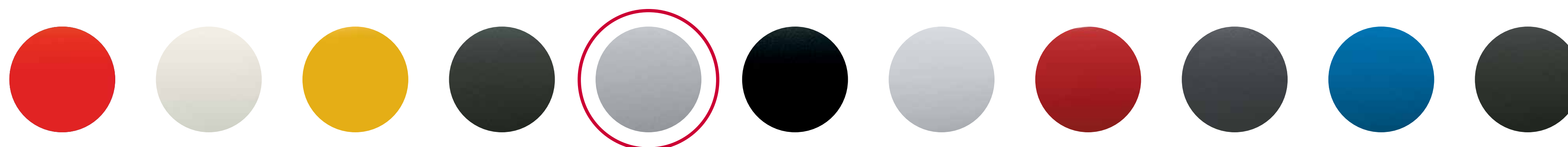

Exterior colors, interior colors, wheels and decorative inlay options will vary based on model and trim level combination and may increase price. See your dealer for details.

Audi R8 Colors



Mythos Black metallic
Shown with Ice Silver Audi sideblades

[Search R8 Inventory ↗](#)

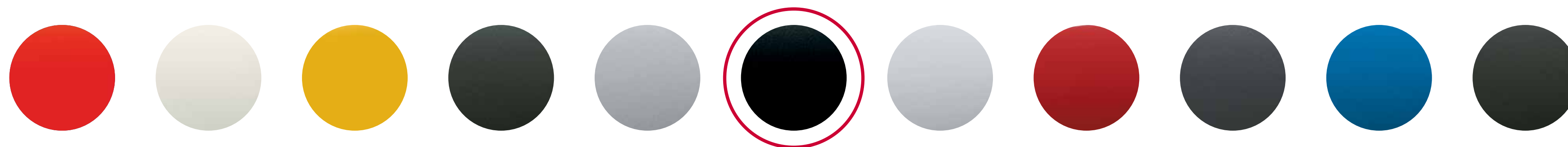

Exterior colors, interior colors, wheels and decorative inlay options will vary based on model and trim level combination and may increase price. See your dealer for details.

Audi R8 Colors



Suzuka Gray metallic

Shown with Ice Silver Audi sideblades

[Search R8 Inventory ↗](#)

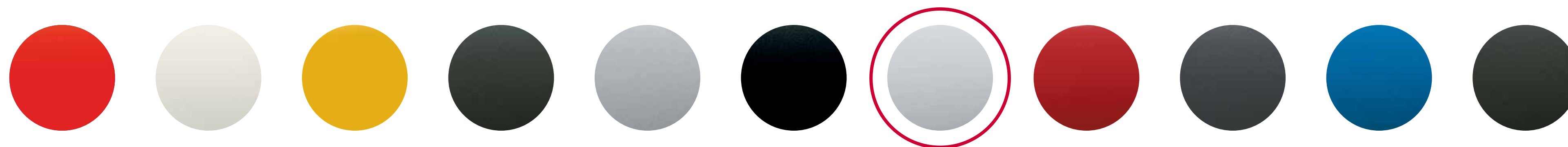

Exterior colors, interior colors, wheels and decorative inlay options will vary based on model and trim level combination and may increase price. See your dealer for details.

Audi R8 Colors



Tango Red metallic

Shown with Ice Silver Audi sideblades

[Search R8 Inventory ↗](#)

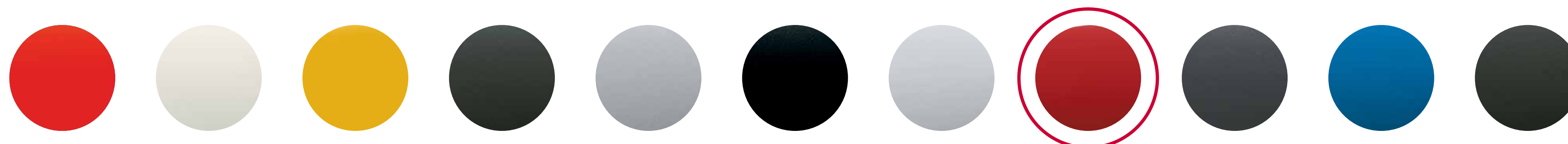

Exterior colors, interior colors, wheels and decorative inlay options will vary based on model and trim level combination and may increase price. See your dealer for details.

Audi R8 Colors



Daytona Gray pearl

Shown with Ice Silver Audi sideblades

[Search R8 Inventory ↗](#)

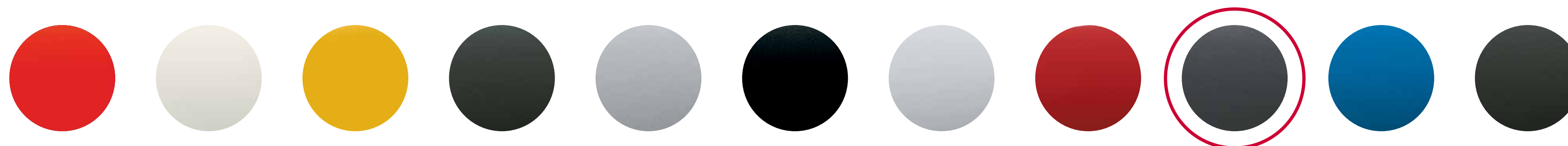

Exterior colors, interior colors, wheels and decorative inlay options will vary based on model and trim level combination and may increase price. See your dealer for details.

Audi R8 Colors



Ara Blue crystal

Shown with Ice Silver Audi sideblades

[Search R8 Inventory ↗](#)

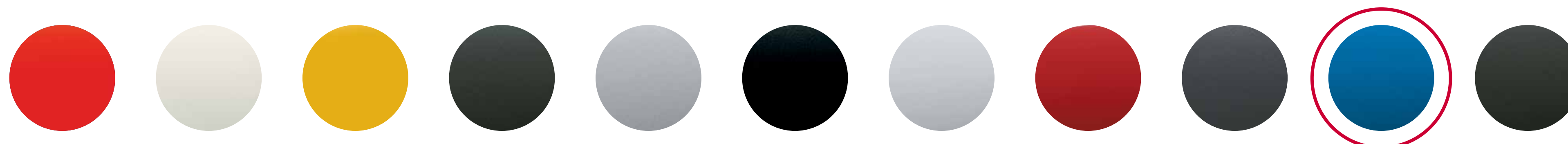

Exterior colors, interior colors, wheels and decorative inlay options will vary based on model and trim level combination and may increase price. See your dealer for details.

Audi R8 Colors



Camouflage Green matte (V10 plus only)

Shown with Carbon Sigma Audi sideblades

[Search R8 Inventory ↗](#)



Exterior colors, interior colors, wheels and decorative inlay options will vary based on model and trim level combination and may increase price. See your dealer for details.

Audi R8 Wheels



19" 5-V-spoke design cast aluminum
Standard on R8 V10



Exterior colors, interior colors, wheels and inlay options will vary based on model and trim level combination and may increase price. See your dealer for details.

Audi R8 Wheels



20" 10-spoke-Y design forged
aluminum-alloy, Silver finish
Optional on R8 V10



Exterior colors, interior colors, wheels and inlay options will vary based on model and trim level combination and may increase price. See your dealer for details.

Audi R8 Wheels



19" 5-double-spoke design forged
aluminum, Titanium finish

Standard on R8 V10 plus



Exterior colors, interior colors, wheels and inlay options will vary based on model and trim level combination and may increase price. See your dealer for details.

Audi R8 Wheels



20" 10-spoke-Y design forged
aluminum-alloy, Titanium finish
Optional on R8 V10 plus



Exterior colors, interior colors, wheels and inlay options will vary based on model and trim level combination and may increase price. See your dealer for details.

Audi R8 Seats and Leather



Black Fine Nappa leather

[Search R8 Inventory ↗](#)

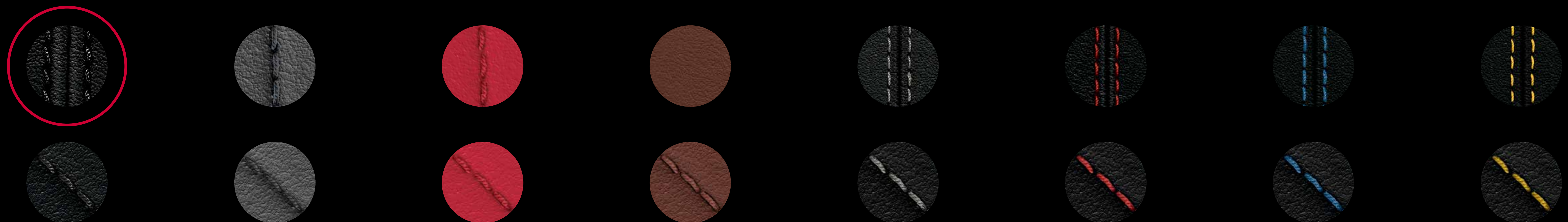

Inlay options will vary based on model and interior color combination and may increase price. See your dealer for details.

Audi R8 Seats and Leather



Rotor Gray Fine Nappa leather

[Search R8 Inventory ↗](#)



Inlay options will vary based on model and interior color combination and may increase price. See your dealer for details.

Audi R8 Seats and Leather

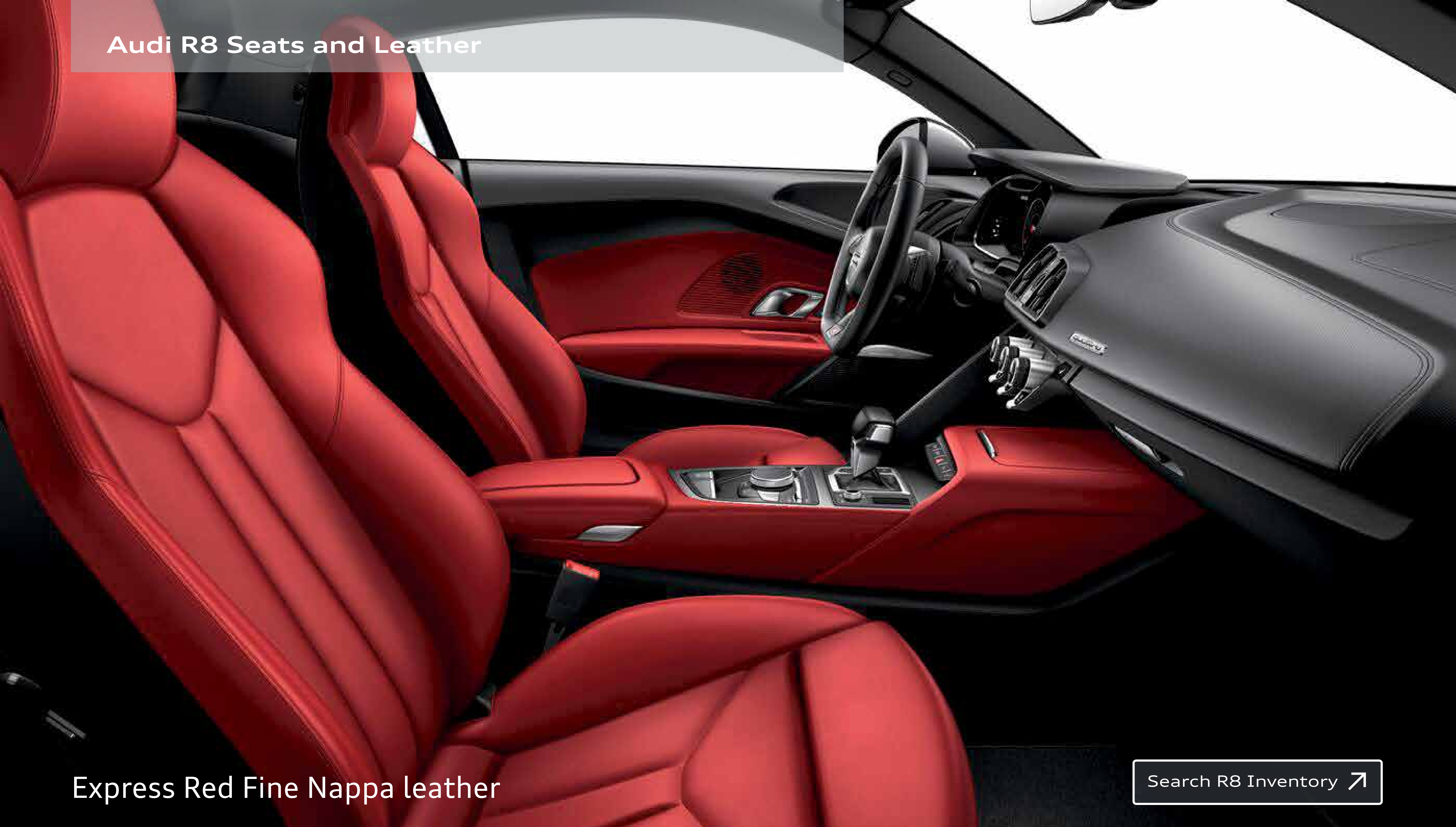

Express Red Fine Nappa leather

[Search R8 Inventory ↗](#)

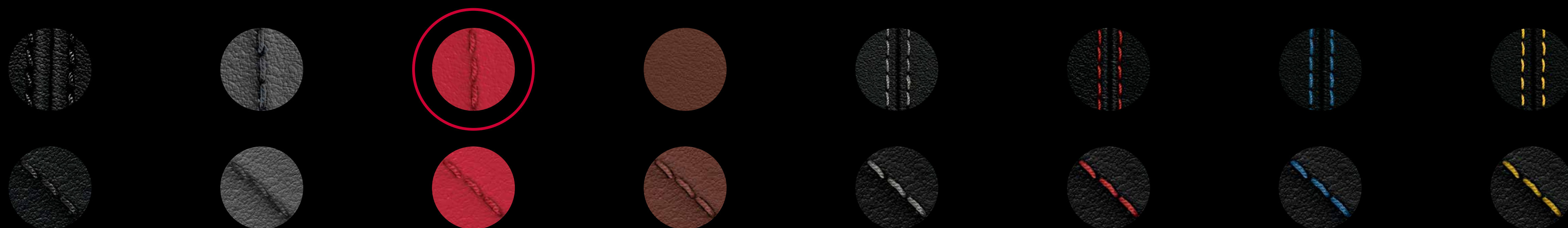

Inlay options will vary based on model and interior color combination and may increase price. See your dealer for details.

Audi R8 Seats and Leather



Vermont Brown Fine Nappa leather

[Search R8 Inventory ↗](#)



Inlay options will vary based on model and interior color combination and may increase price. See your dealer for details.

Audi R8 Seats and Leather



Black Fine Nappa leather with Silver contrast stitching

[Search R8 Inventory ↗](#)

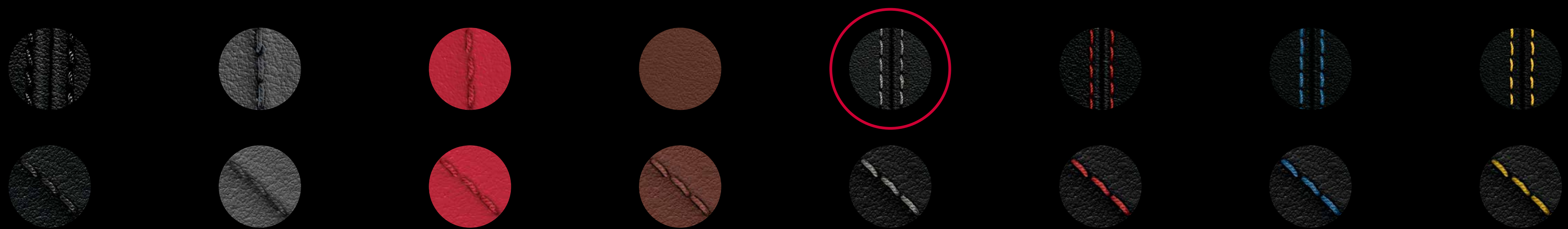

Inlay options will vary based on model and interior color combination and may increase price. See your dealer for details.

Audi R8 Seats and Leather



Black Fine Nappa leather with Express Red contrast stitching

[Search R8 Inventory ↗](#)



Inlay options will vary based on model and interior color combination and may increase price. See your dealer for details.

Audi R8 Seats and Leather



Black Fine Nappa leather with Ara Blue contrast stitching

[Search R8 Inventory ↗](#)

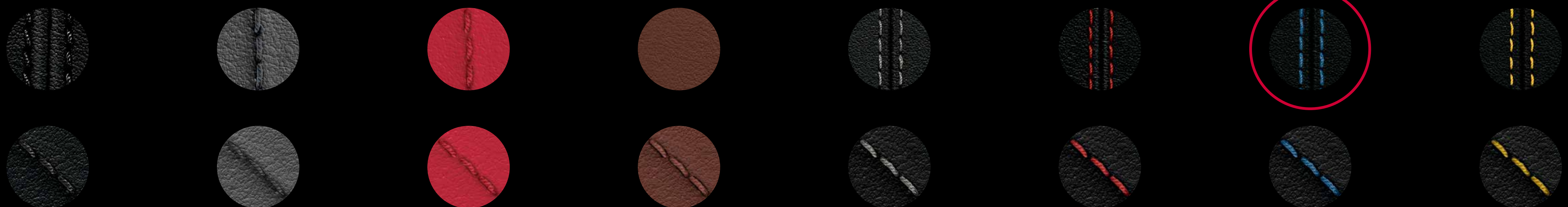

Inlay options will vary based on model and interior color combination and may increase price. See your dealer for details.

Audi R8 Seats and Leather



Black Fine Nappa leather with Vegas Yellow contrast stitching

[Search R8 Inventory ↗](#)

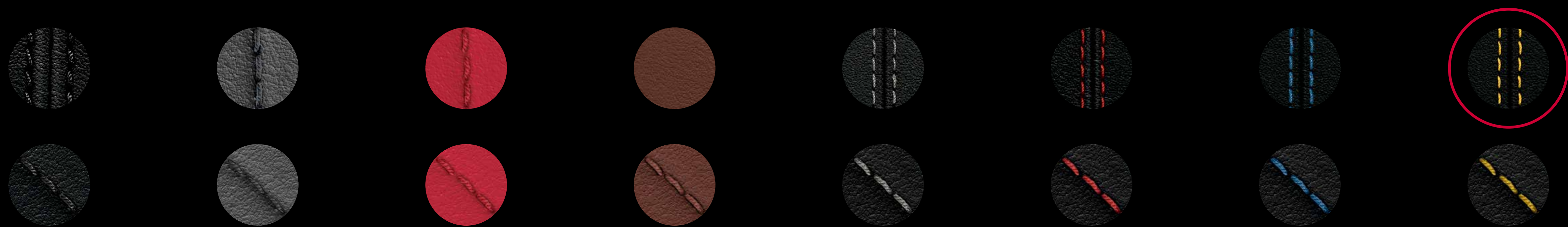

Inlay options will vary based on model and interior color combination and may increase price. See your dealer for details.

Audi R8 Seats and Leather



Black Fine Nappa leather with diamond stitching

[Search R8 Inventory ↗](#)

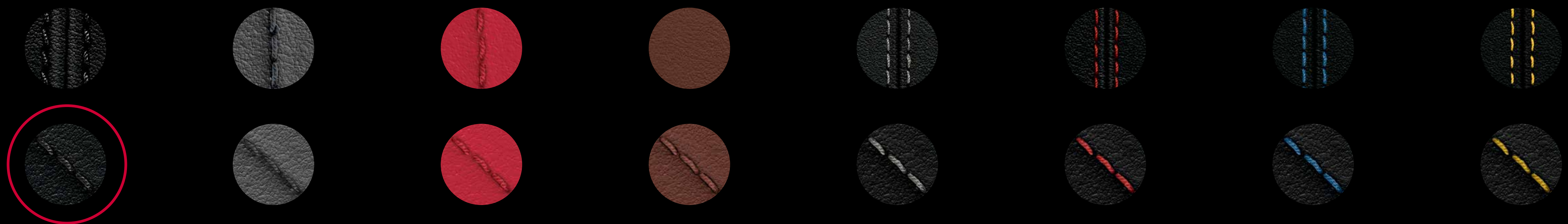

Inlay options will vary based on model and interior color combination and may increase price. See your dealer for details.

Audi R8 Seats and Leather



Rotor Gray Fine Nappa leather with diamond stitching

[Search R8 Inventory ↗](#)



Inlay options will vary based on model and interior color combination and may increase price. See your dealer for details.

Audi R8 Seats and Leather

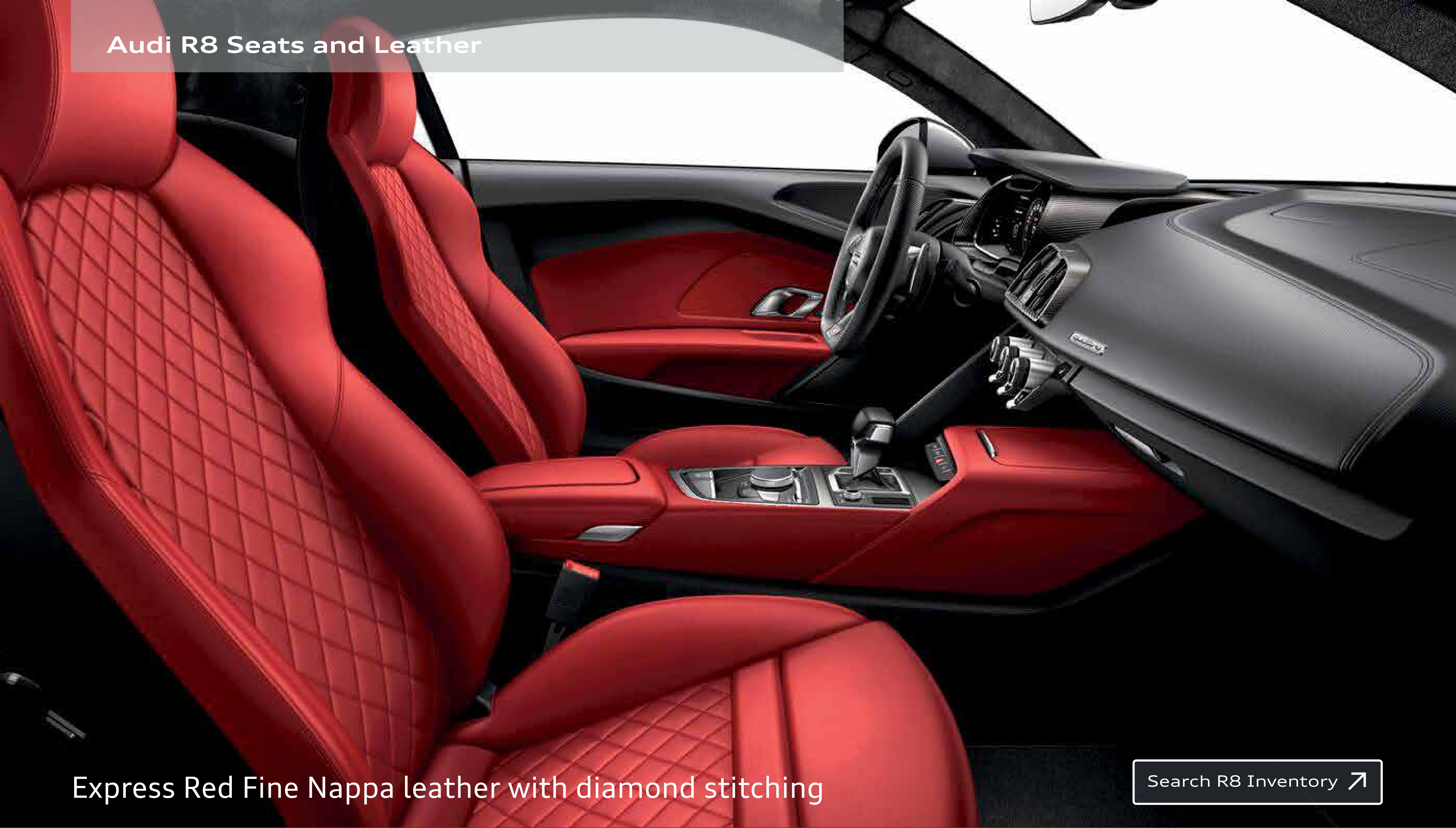

Express Red Fine Nappa leather with diamond stitching

[Search R8 Inventory ↗](#)

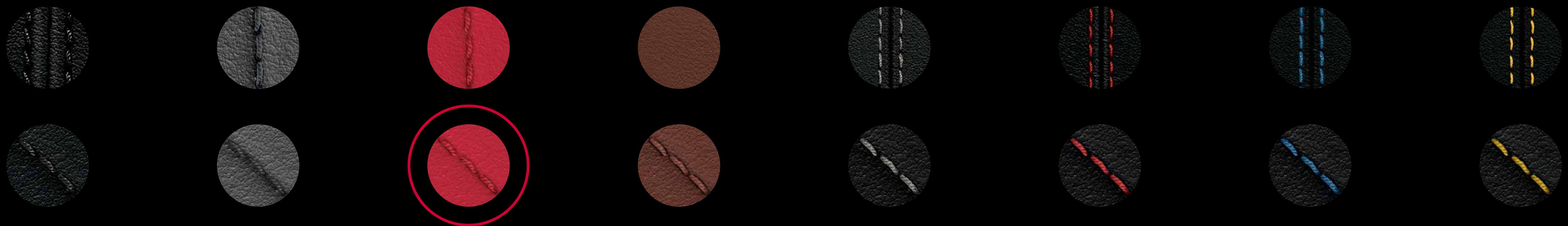

Inlay options will vary based on model and interior color combination and may increase price. See your dealer for details.

Audi R8 Seats and Leather

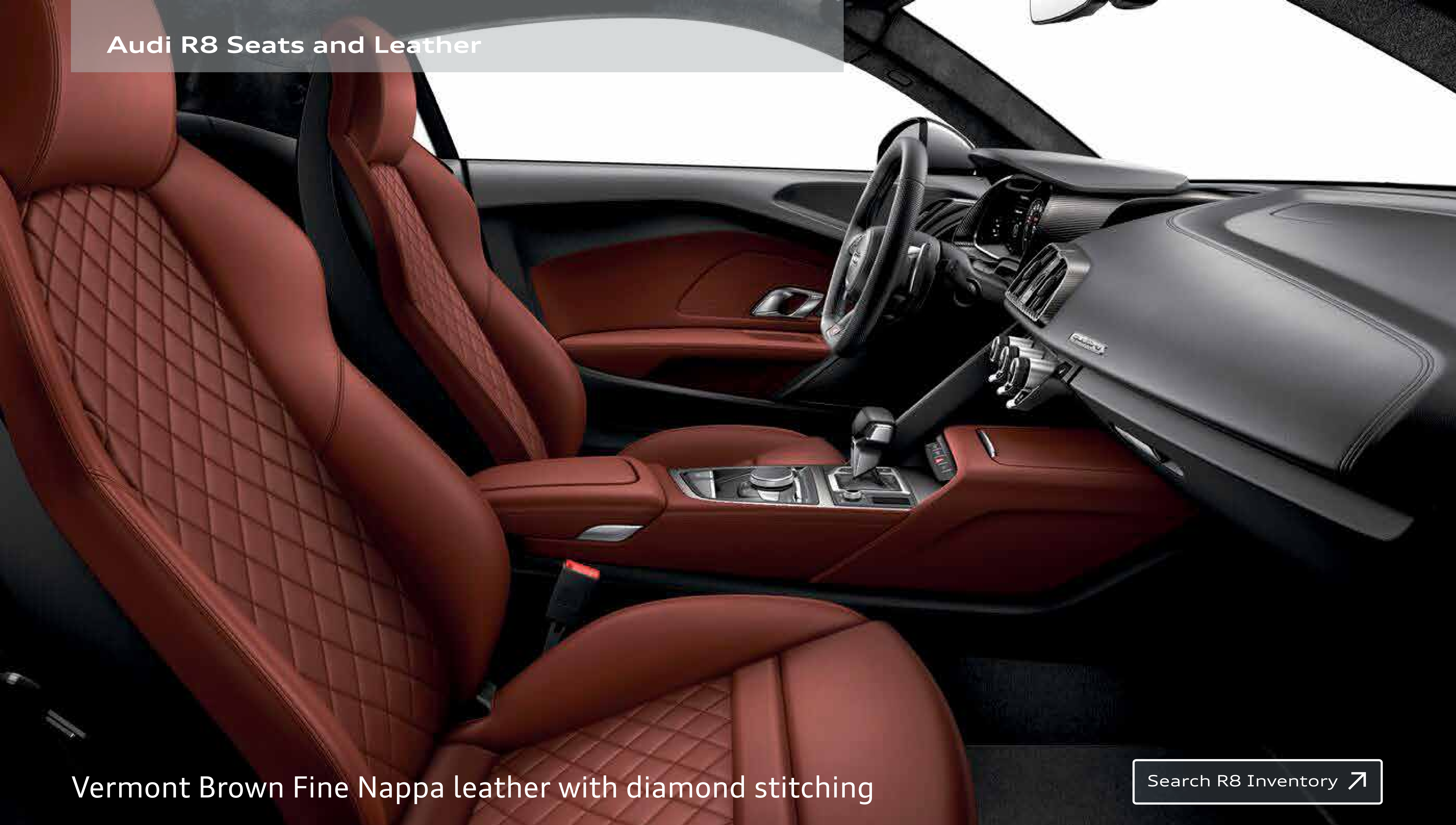

Vermont Brown Fine Nappa leather with diamond stitching

[Search R8 Inventory ↗](#)



Inlay options will vary based on model and interior color combination and may increase price. See your dealer for details.

Audi R8 Seats and Leather



Black Fine Nappa leather with Silver contrast diamond stitching

[Search R8 Inventory ↗](#)



Inlay options will vary based on model and interior color combination and may increase price. See your dealer for details.

Audi R8 Seats and Leather



Black Fine Nappa leather with Express Red contrast diamond stitching

[Search R8 Inventory ↗](#)

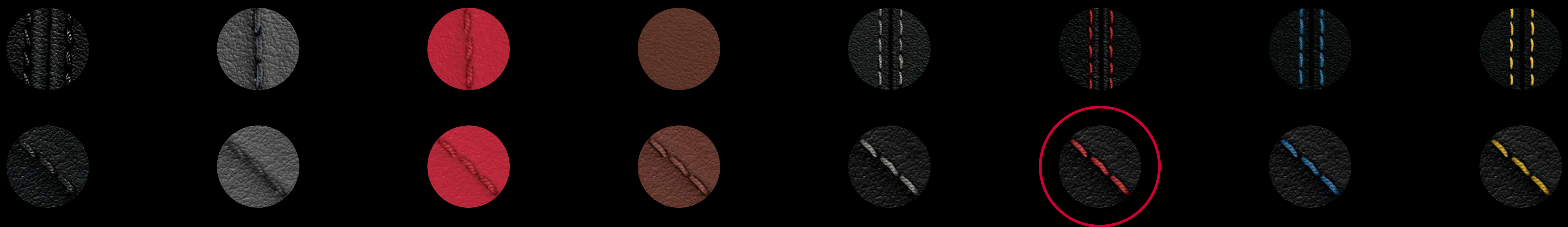

Inlay options will vary based on model and interior color combination and may increase price. See your dealer for details.

Audi R8 Seats and Leather

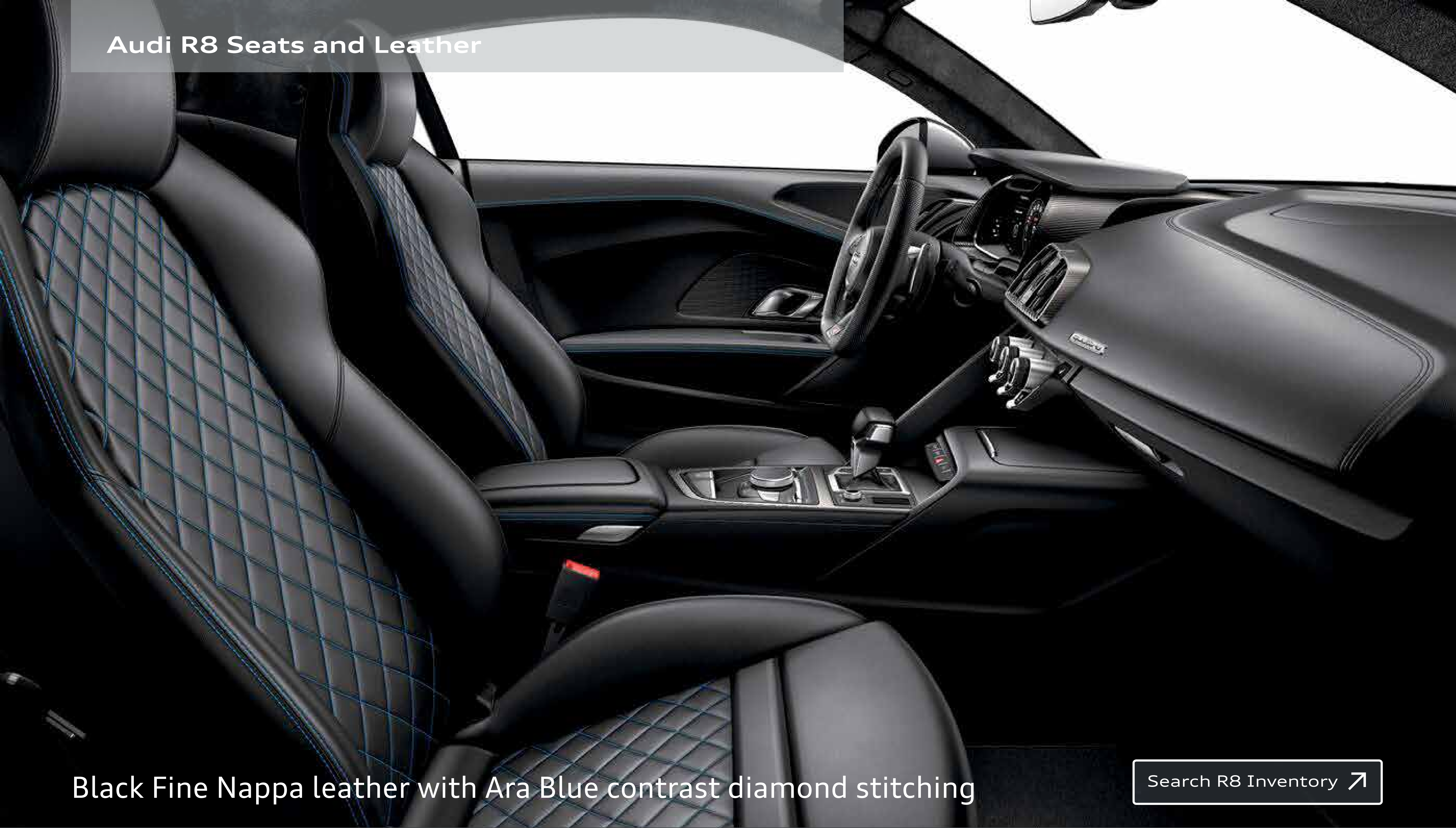

Black Fine Nappa leather with Ara Blue contrast diamond stitching

[Search R8 Inventory ↗](#)

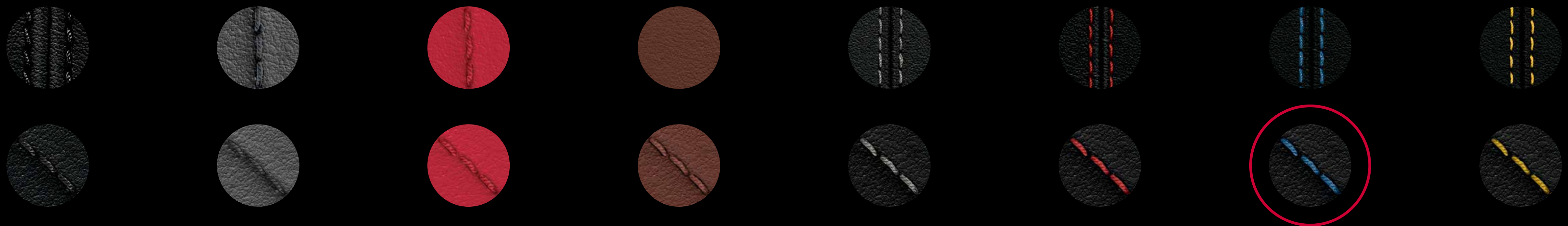

Inlay options will vary based on model and interior color combination and may increase price. See your dealer for details.

Audi R8 Seats and Leather

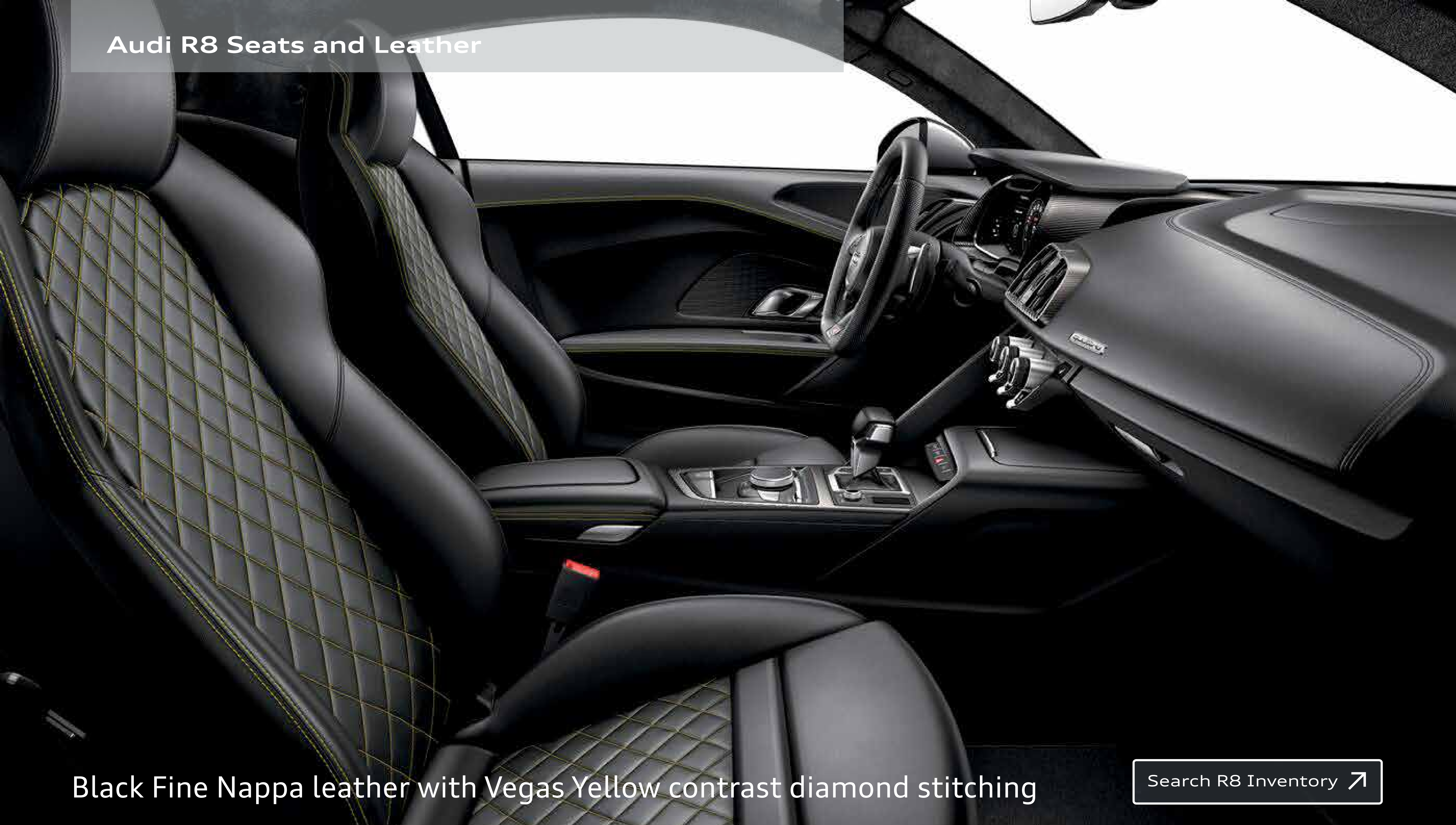

Black Fine Nappa leather with Vegas Yellow contrast diamond stitching

[Search R8 Inventory ↗](#)



Inlay options will vary based on model and interior color combination and may increase price. See your dealer for details.

Audi R8 Inlays



Matte Anthracite Anodized Aluminum inlay

[Schedule a test drive ↗](#)

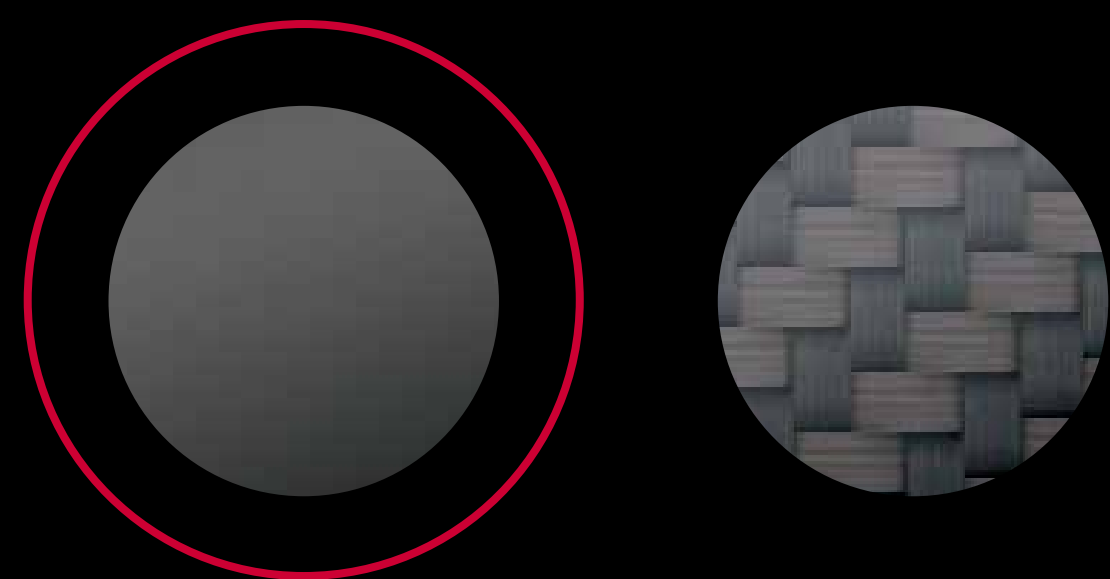

Inlay options will vary based on model and interior color combination and may increase price. See your dealer for details.

Audi R8 Inlays



Carbon Sigma Matte inlay

[Schedule a test drive ↗](#)

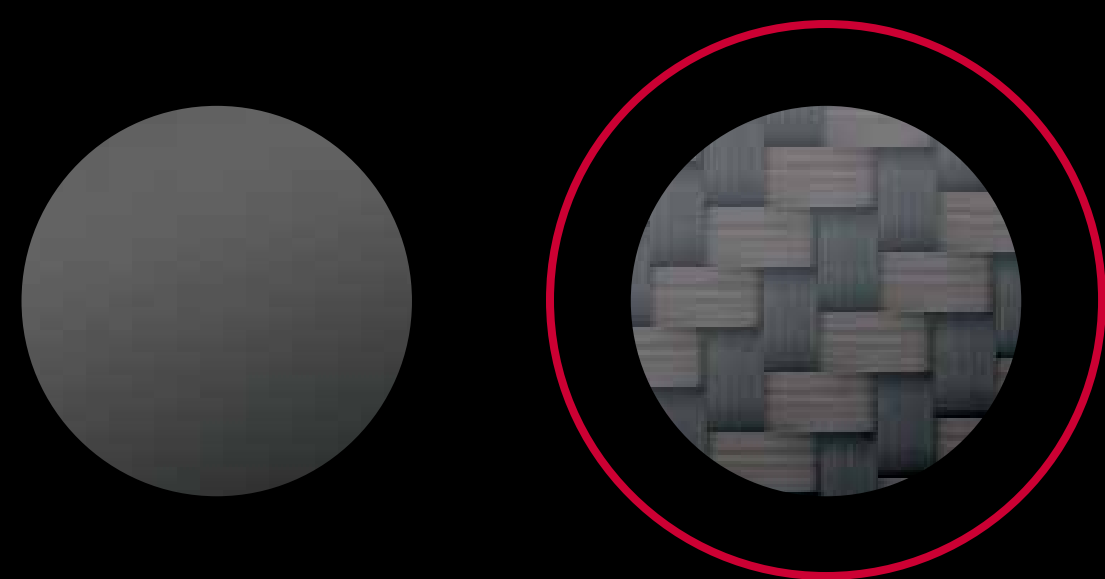

Inlay options will vary based on model and interior color combination and may increase price. See your dealer for details.

Audi exclusive



AN EXPRESSION OF STYLE.
A STATEMENT OF YOUR IDENTITY.

Swipe

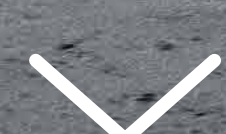

Audi exclusive

Audi exclusive provides you with a great variety of options for making your R8 truly yours—you can choose from more than 80 paint colors, including five matte finishes, as well as 17 shades of Fine Nappa leather for your seats, trims and contrast stitching. Audi exclusive gives future owners a chance to put a true, personal statement on their new R8.

[Learn more about Audi exclusive](#) ↗

PULL ^

Audi exclusive

- Alabaster White leather
- Magnolia White leather
- Sand Beige leather
- Cognac Brown leather
- Calendula Yellow leather
- Powder Beige leather
- Saddle Brown leather
- Crimson Red leather
- Cloudy Gray leather
- Jet Gray leather
- Smoky Blue leather
- Night Blue leather
- Iceland Green leather
- Havana Brown leather
- Classic Red leather
- Chestnut Brown leather
- Black leather

Audi R8 Specifications

R8



R8 V10 plus



Engineering / Performance



Transmission / Suspension / Chassis



Exterior



Interior



Infotainment / Technology



Safety



Available packages



Stand-alone Options



[Build your 2017 R8 ↗](#)

R8



R8 V10 plus



Engineering / Performance



5.2-liter FSI® dual-injection V10

540 hp/398 lb-ft torque

cylinder on demand™ engine efficiency technology

Acceleration (0-60 mph) in 3.5 seconds

Top track speed of 199 mph¹

5.2-liter FSI® dual-injection V10

610 hp/413 lb-ft torque

cylinder on demand™ engine efficiency technology

Acceleration (0-60 mph) in 3.2 seconds

Top track speed of 205 mph¹

¹ Always obey all speed and traffic laws.

Transmission / Suspension / Chassis



Exterior



Interior



Infotainment / Technology



Safety



Available packages



Stand-alone Options



Build your 2017 R8 

R8



R8 V10 plus



Transmission / Suspension / Chassis



Seven-speed S tronic® dual-clutch transmission with shift-by-wire technology

Seven-speed S tronic® dual-clutch transmission with shift-by-wire technology

Audi magnetic ride

Sport-tuned fixed suspension

14.4" ventilated wave-design front disc brakes with eight-piston calipers and 14.0" ventilated wave-design rear disc brakes with four-piston calipers (with R8 badging)

15.0" ventilated Audi ceramic front disc brakes with six-piston calipers and 14.0" ventilated ceramic rear disc brakes with four-piston calipers (Anthracite Gray calipers feature the Audi ceramic logo)

Engineering / Performance



Exterior



Interior



Infotainment / Technology



Safety



Available packages



Stand-alone Options



Build your 2017 R8 [↗](#)

Audi R8 Specifications

R8



R8 V10 plus



Exterior

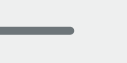

Singleframe® grille includes 3D honeycomb design with Anthracite Gray matte finish

Anthracite Black matte front lip spoiler

Anthracite Black gloss front fascia air inlets

Anthracite Black gloss rear fascia air outlets

Anthracite Black matte rear diffuser

Full LED headlights

LED taillights with dynamic turn signals

Rear fog lights

Body-colored exterior side mirror housings

Power-adjustable, power-folding, auto-dimming, heated exterior side mirrors

LED turn signals integrated into the exterior side mirror housings

Ice Silver sideblade

Engine compartment with LED lighting

Adaptive rear spoiler

Integrated twin-trapezoidal exhaust outlets

Singleframe® grille includes 3D honeycomb design with Anthracite Gray gloss finish

Carbon fiber front lip spoiler

Anthracite Black gloss front fascia air inlets

Anthracite Black gloss rear fascia air outlets

Carbon fiber rear diffuser

Full LED headlights

LED taillights with dynamic turn signals

Rear fog lights

Carbon fiber exterior side mirror housings

Power-adjustable, power-folding, auto-dimming, heated exterior side mirrors

LED turn signals integrated into the exterior side mirror housings

Carbon Sigma sideblade

Carbon fiber engine compartment

Carbon fiber fixed rear spoiler

Integrated twin-trapezoidal exhaust outlets

Sport exhaust with Black tips

Engineering / Performance



Transmission / Suspension / Chassis



Interior



Infotainment / Technology



Safety



Available packages



Stand-alone Options



Build your 2017 R8 [↗](#)

Audi R8 Specifications

R8



R8 V10 plus



Interior



Automatic climate control

Three-spoke multifunction flat-bottom sport steering wheel with shift paddles

Two steering wheel-mounted satellite buttons (engine Start/Stop and Audi drive select)

Tilt and telescopic manually adjustable steering column

Monoposto cockpit design

Driver's knee pad

Stainless steel pedals

Auto-dimming interior rear view mirror with digital compass

Matte anthracite anodized aluminum inlays

Black Alcantara® headliner

Leather package

Fine Nappa leather seats

18-way power sport seats including 4-way power lumbar, pneumatic leg and side bolster adjustments

Heated seats (three-step)

Power windows

Floor mats

Illuminated aluminum door sill inlays

Automatic climate control

Three-spoke multifunction flat-bottom sport steering wheel with shift paddles

Four steering wheel-mounted satellite buttons (includes R8 V10 standard controls plus Performance mode selector and Sport exhaust)

Tilt and telescopic manually adjustable steering column

Monoposto cockpit design

Driver's knee pad

Stainless steel pedals

Auto-dimming interior rear view mirror with digital compass

Carbon Sigma matte inlays

Black Alcantara® headliner

Leather package

Fine Nappa leather seats

Racing shell seats with power height adjustment

Heated seats (three-step)

Power windows

Floor mats

Illuminated aluminum door sill inlays with matte carbon fiber surround

Engineering / Performance



Transmission / Suspension / Chassis



Exterior



Infotainment / Technology



Safety



Available packages



Stand-alone Options



Build your 2017 R8 [↗](#)

Audi R8 Specifications

R8



R8 V10 plus



Infotainment / Technology



Audi virtual cockpit

MMI® navigation plus with voice control system

MMI® touch with handwriting-recognition technology

Audi connect® with six-month trial subscription

Bang & Olufsen® Sound System with 13 speakers and 550 watts

HD Radio™ Technology

SiriusXM® Satellite Radio with 90-day trial subscription

INRIX XD® Traffic

SDXC card slots

Audi music interface with two USB ports

BLUETOOTH® streaming audio for compatible devices

BLUETOOTH® wireless technology preparation for compatible mobile phones

Embedded safety belt microphones (for voice control and BLUETOOTH® hands-free voice clarity)

Garage door opener (HomeLink®)

Audi advanced key—keyless start, stop and entry

Cruise control with coast resume and accelerate features

High-beam assistant

Audi drive select

Parking system plus with rear view camera (front and rear acoustic sensors)

Rain/light sensor for automatic windshield wipers and headlights

Audi virtual cockpit

MMI® navigation plus with voice control system

MMI® touch with handwriting-recognition technology

Audi connect® with six-month trial subscription

Audi sound system with five speakers and 140 watts

HD Radio™ Technology

SiriusXM® Satellite Radio with 90-day trial subscription

INRIX XD® Traffic

SDXC card slots

Audi music interface with two USB ports

BLUETOOTH® streaming audio for compatible devices

BLUETOOTH® wireless technology preparation for compatible mobile phones

Embedded safety belt microphones (for voice control and BLUETOOTH® hands-free voice clarity)

Garage door opener (HomeLink®)

Audi advanced key—keyless start, stop and entry

Cruise control with coast resume and accelerate features

High-beam assistant

Audi drive select

Parking system plus with rear view camera (front and rear acoustic sensors)

Rain/light sensor for automatic windshield wipers and headlights

Engineering / Performance



Transmission / Suspension / Chassis



Exterior



Interior



Safety



Available packages



Stand-alone Options



Build your 2017 R8 [↗](#)

R8



R8 V10 plus



Safety

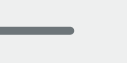

Driver single-stage airbag and front passenger dual-stage airbag

Driver single-stage airbag and front passenger dual-stage airbag

Driver and front passenger three-point safety belts with pretensioning and adaptive force limiters

Driver and front passenger three-point safety belts with pretensioning and adaptive force limiters

Front thorax side airbags

Front thorax side airbags

Sideguard® head-curtain airbags

Sideguard® head-curtain airbags

Driver and front passenger knee airbags

Driver and front passenger knee airbags

Integrated front seat head restraints

Integrated front seat head restraints

Front passenger occupant detection for airbags

Front passenger occupant detection for airbags

Power central locking system with safety unlock feature if airbags deploy

Power central locking system with safety unlock feature if airbags deploy

Electronic Stability Control (ESC) with secondary collision brake assist and traction control (ASR)

Electronic Stability Control (ESC) with secondary collision brake assist and traction control (ASR)

Anti-lock Brake System (ABS) with Electronic Brake-pressure Distribution (EBD) and brake assist

Anti-lock Brake System (ABS) with Electronic Brake-pressure Distribution (EBD) and brake assist

Direct tire pressure monitoring system

Direct tire pressure monitoring system

Electromechanical parking brake

Electromechanical parking brake

Anti-theft alarm system with immobilizer

Anti-theft alarm system with immobilizer

Engineering / Performance



Transmission / Suspension / Chassis



Exterior



Interior



Infotainment / Technology



Available packages



Stand-alone Options



Build your 2017 R8 [↗](#)

R8



R8 V10 plus



Available packages

Diamond Stitch Leather package

- > Fine Nappa leather seats with diamond stitching
- > Full Leather package
- > Alcantara® headliner with diamond stitching

Carbon Exterior package

- > Carbon fiber engine compartment
- > Carbon Sigma sideblades

Carbon Interior package

- > Carbon Sigma matte inlays (instrument panel housing, upper door panel, center console and climate control vent surrounds)

Ceramic Brake package

- > 15.0" ventilated Audi ceramic front disc brakes with six-piston calipers and 14.0" ventilated ceramic rear disc brakes with four-piston calipers (Anthracite Gray calipers feature the Audi ceramic logo)

Diamond Stitch Leather package with Sport Seats

- > Heated 18-way power sport seats including 4-way power lumbar, pneumatic leg and side bolster adjustments
- > Fine Nappa leather seats with diamond stitching
- > Full Leather package
- > Alcantara® headliner with diamond stitching

Engineering / Performance



Transmission / Suspension / Chassis



Exterior



Interior



Infotainment / Technology



Safety



Stand-alone Options



Build your 2017 R8 

Audi R8 Specifications

R8



R8 V10 plus



Stand-alone Options

- > 20" 10-spoke-Y design forged aluminum-alloy wheels (Silver finish) with 245/30 front and 305/30 rear summer performance tires
- > Red brake calipers
- > Dynamic steering
- > Contrast stitching
- > Full leather package (airbag cap, dashboard, instrument panel top, door panels, rear firewall partition and sides covered in Fine Nappa leather)

- > 20" 10-spoke-Y design forged aluminum-alloy wheels (Titanium finish) with 245/30 front and 305/30 rear summer performance tires
- > Dynamic steering
- > Bang & Olufsen® Sound System with 13 speakers and 550 watts
- > Contrast stitching
- > Full leather package (airbag cap, dashboard, instrument panel top, door panels, rear firewall partition and sides covered in Fine Nappa leather)

Engineering / Performance



Transmission / Suspension / Chassis



Exterior



Interior



Infotainment / Technology



Safety



Available packages



Build your 2017 R8 [↗](#)

Technical Specifications

Engineering | Performance

	R8 V10	R8 V10 plus
Engine type	V10 gasoline engine	V10 gasoline engine
Engine block/Cylinder head	Aluminum-alloy incorporating silicon crystals/Aluminum-alloy	Aluminum-alloy incorporating silicon crystals/Aluminum-alloy
Displacement (cc)/Bore and stroke (mm)	5,204/84.5 x 92.8	5,204/84.5 x 92.8
Horsepower (@ rpm)	540 @ 7,800	610 @ 8,250
Torque (lb-ft @ rpm)	398 @ 6,500	413 @ 6,500
Compression ratio	12.5:1	12.5:1
Valvetrain	DOHC chain driven	DOHC chain driven
Induction/Fuel injection	Combined FSI® and indirect (multipoint) injection	Combined FSI® and indirect (multipoint) injection
Acceleration (0–60 mph)	3.5 seconds	3.2 seconds
Top track speed ¹	199 mph	205 mph

Transmission | Drivetrain

Seven-speed S tronic® transmission with quattro® all-wheel drive	■	■
--	---	---

Body | Suspension | Chassis

Lightweight construction—ASF® multi-material space frame	■	■
Double-wishbone front four-link independent steel spring suspension	■	■
Double-wishbone rear four-link independent steel spring suspension	■	■
Audi magnetic ride (with Dynamic, Comfort and Auto suspension settings)	■	—
Sport-tuned fixed suspension	—	■
Ventilated wave-design front disc/Ventilated wave-design rear disc brakes (in)	14.4/14.0	—
Ventilated Audi ceramic front disc/Ventilated ceramic rear disc brakes (in)	Available	15.0/14.0
Electromechanical power steering system	■	■
Dynamic steering system	Available	Available
Steering ratio	15.7:1	15.7:1
Turning circle, curb-to-curb (ft)	36.7	36.7

[Schedule a test drive ↗](#)

■ Standard — Not applicable

¹ Always obey all speed and traffic laws.

Technical Specifications

Exterior measurements

	R8 V10	R8 V10 plus
Wheelbase (in)	104.3	104.3
Length (in)	174.3	174.3
Height (in)	48.8	48.8
Overall width with mirrors (in)	80.2	80.2
Overall width without mirrors (in)	76.4	76.4
Track (in, front/rear)	64.5/63.0	64.5/63.0
Curb weight with front-wheel drive (lb)	3,737	3,627
Drag coefficient (Cw)	0.34 - 0.35	0.36

Interior measurements

Head room (in, front)	38.5	38.5
Leg room (in, front)	40.9	40.9
Shoulder room (in, front)	55.1	55.1
Cargo volume (cu ft)	8.0	8.0
Seating capacity	2	2

EPA mileage estimates | Capacities | Emissions

S tronic® automatic transmission (city/highway/combined) ¹	14/22/17	14/22/17
Engine oil (qt)	8.8	8.8
Fuel (gal)	21.9	19.3
Recommended fuel	Premium	Premium

Schedule a test drive 

■ Standard — Not applicable

¹ 14 city/22 highway mpg (2017 Audi R8 5.2-liter FSI® V10 engine with seven-speed S tronic® transmission and quattro® all-wheel drive). EPA estimates. Your mileage will vary and depends on several factors, including your driving habits and vehicle condition.

To explore more and get acquainted with the Audi family:

More

[R8 Launch experience](#)

[Take our survey](#)

Buy

[Configure your R8](#)



[Explore Offers](#)



[Search local R8 Inventory](#)



R8 2017

Audi of America
Audiusa.com
Facebook.com/Audi

Tap here for important information about this brochure. >>

R8 2017

Audi of America
Audiusa.com
Facebook.com/Audi



Note: A word about this brochure. Audi of America, Inc., believes the specifications in this brochure to be correct at the time of printing. However, specifications, standard equipment, options, fabrics, and colors are subject to change without notice. Some equipment may be unavailable when your vehicle is built. Please ask your dealer for advice concerning current availability of standard and optional equipment, and your dealer will verify that your vehicle will include the equipment you ordered. Vehicles in this brochure are shown with optional equipment. See your dealer for complete details on the Audi New Vehicle Limited Warranty, twelve-year limited warranty against corrosion perforation, and Audi 24/7 Roadside Assistance. (Roadside assistance coverage provided by Road America in the U.S. Certain conditions apply; see your dealer for details.) Tires supplied by various manufacturers. "Audi," all model names, "Audi connect," "Audi pre sense," "Audi Sport," "MMI," "quattro," "S line," "S tronic," "Sideguard," "Singleframe," "TFSI," "ultra" and the four rings logo are registered trademarks of AUDI AG. "Apple" and "App Store" are registered trademarks of Apple Inc. "Bang & Olufsen" is a registered trademark of Bang & Olufsen. The BLUETOOTH word mark and logos are owned by the Bluetooth SIG, Inc., and any use of such marks by AUDI AG is under license. "Facebook" is a registered trademark of Facebook, Inc. "Google Play" is a trademark of Google Inc. © 2016 Google Inc. All rights reserved. "HomeLink" is a registered trademark of Gentex Corporation. "INRIX XD" is a registered trademark of INRIX, Inc. "SiriusXM" and all related marks and logos are trademarks of Sirius XM Radio Inc. and its subsidiaries. "Wi-Fi" is a registered trademark of the Wi-Fi Alliance. All other trademarks are the property of their respective owners. Some European models shown. Some features may not be available at time of order.