

4x4



1967 CHEVROLET 4-WHEEL DRIVE TRUCKS





FLEETSIDE PICKUP

The crisp new styling of Fleetside pickups takes full advantage of Chevy's low-profile 4 x 4 design. Refinements run from the sleek, sloped hood all the way back to the new tailgate. Pickup box side panels and tailgate are double-walled from top to bottom. You even get a choice of floors—tough steel or seasoned wood. For working convenience, there's a new quick-release tailgate that can be operated with one hand. Up front, you'll find a host of new

safety features — deep-dish steering wheel, telescoping lower steering shaft, padded dash and sun visor, recessed instruments, smooth-contoured control knobs, seat belts with retractors, dual master cylinder braking system with warning light, and many others. 1967 Fleetside 4-wheel drive models are available with 6½-foot or 8-foot bodies and GVW ratings as high as 7,600 lbs. Power choices include Sixes and V8's ranging up to 327 cubic inches and 220 horsepower.

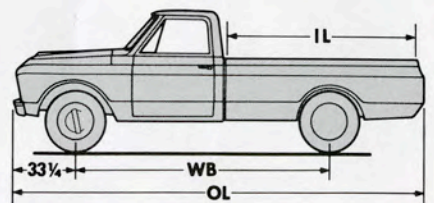

Series	Fleetside Pickup Dimensions		
	WB (in.) Wheelbase	IL (in.) Inside Length	OL (in.) Overall Length
KS/KE 10734	115	78	188
KS/KE 10934	127	98	208
KS/KE 20934			

STEPSIDE PICKUP

All-new Stepsides incorporate low overall height, advanced safety features and improved resistance to corrosion. Bodies are contained between rear fenders for an unobstructed load area. Select wood floors have recessed steel skid strips. Tailgate closes securely with wedge-type anti-rattle latches. 1/2- and 3/4-ton sizes with 6 1/2- or 8-ft. bodies.

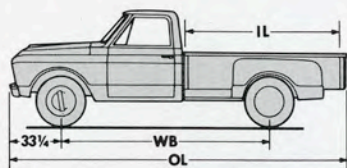

Stepside Pickup Dimensions			
Series	WB (in.) Wheelbase	IL (in.) Inside Length	OL (in.) Overall Length
KS/KE 10704	115	78	188
KS/KE 10904	127	98	208
KS/KE 20904			



CHASSIS-CAB

Cab design reflects Chevrolet's trim new '67 styling and tougher build. Low-profile construction utilizes a 34-in.-wide frame to handle standard bodies from 6 feet to 8 1/2 feet in length. GVW ratings range all the way up to 7,600 lbs. Plenty of power for big jobs with engines up to a 327-cubic-inch V8 that develops 220 horsepower.

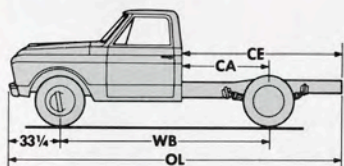

Chassis-Cab Dimensions				
Series	WB (in.) Wheelbase	CA (in.) Cab-to-Axle	CE (in.) Cab-to-Frame End	OL (in.) Overall Length
KS/KE 10703	115	42	76	182
KS/KE 10903	127	54	96	202
KS/KE 20903				



SUBURBAN & PANEL

Spacious 9-ft. bodies afford plenty of room. Suburban accommodates up to 9 adults . . . or 181 cu. ft. of cargo behind the three-man front seat. Third side door provides better right-hand access. Panel truck handles 207 cu. ft. of cargo. Low loading height makes work easier. Both in 1/2- and 3/4-ton models with a wide choice of optional equipment.

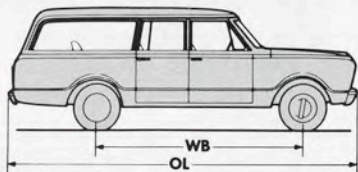

Suburban & Panel Dimensions		
Series	WB (in.) Wheelbase	OL (in.) Overall Length
KS/KE 10906-16		
KS/KE 20906-16		
KS/KE 10905	127	216
KS/KE 20905		



CHECK THE NEW CHEVY 4 x 4's

We Lowered Overall Height . . . and Raised Overall Efficiency

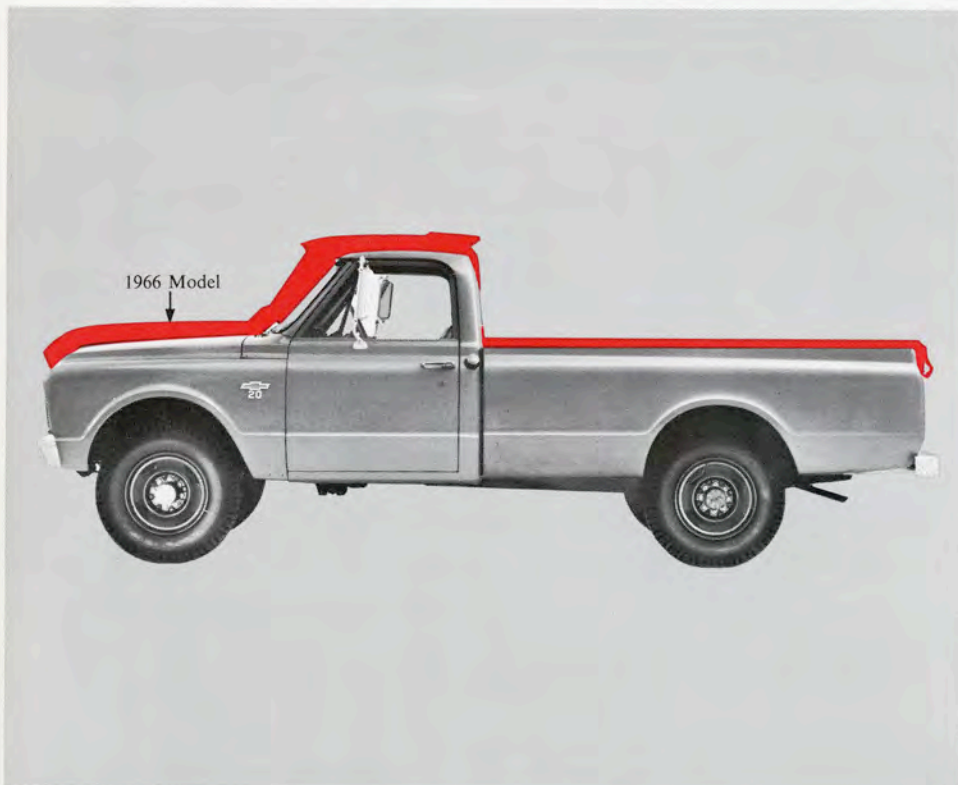

Meet Chevy's totally new 4-wheel drive models. Note the old "on stilts" look is gone. Thanks to advanced engineering and a redesigned power train configuration, vehicle height has been trimmed as much as five inches compared to last year's models. Yet adequate ground clearance and approach angle have been retained. This means you can still keep going when the going gets rough.

The lower lines of Chevrolet's new

4 x 4's offer a lot more than improved appearance—wind resistance is reduced and the center of gravity is closer to the ground. Performance and ride show significant improvement. Getting in and out is easier, too. And the lower loading height gives added convenience.

Whichever 4-wheel drive Chevy fits your needs, you'll find a long list of improvements for 1967. Check them over and see for yourself.

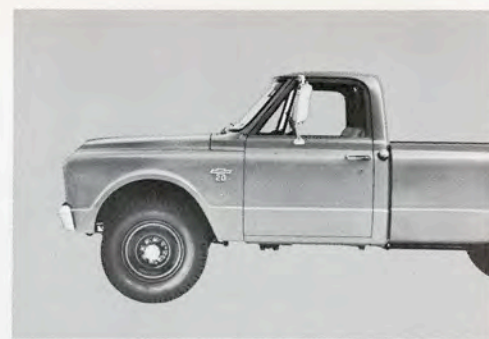

NEW CAB AND FRONT END

Everything's new up front. Hoods are sloped for better visibility and a leaner look. Corrosion resistance is improved with undercoated one-piece wheelhouses to ward off road splash. Interiors have extra comfort and convenience—plus a long list of new safety features. And the entire body structure has been strengthened. You get all the toughness you need in a go-anywhere 4 x 4.

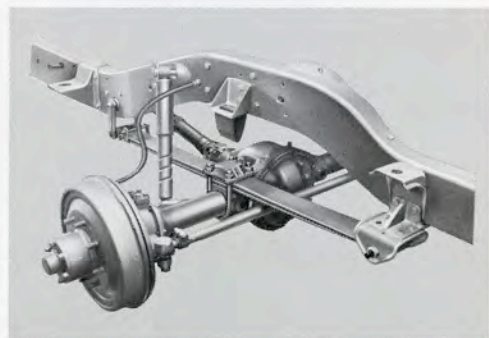

NEW TAPERED-LEAF SPRINGS

Improved ride is engineered into new Chevy 4-wheel drive trucks. Front and rear suspensions feature the advanced design of tapered-leaf springs. Benefits include more uniform riding qualities and a significant reduction in unsprung weight. Assemblies consist of two or three tapered leaves with Delrin plastic liners to minimize interleaf friction. Using a special process, each leaf is shot-peened under stress to increase durability.

FLEETSIDE PICKUPS MAKE IDEAL CAMPERS

Camping buffs know there's nothing like a Fleetside 4 x 4 to carry you into backwoods campsites where hunting and fishing are best—and to get you out again. For an ideal 4-wheel drive vehicle that can pack a camper body over rough trails, start with a husky Chevrolet ½-ton Fleetside pickup. Add a few options like 2,500-lb. rear springs, heavy-duty rear shock absorbers and severe-duty tires for topnotch handling and long, trouble-free life under grueling camping conditions.



BRAWNY 4-WHEEL DRIVE CHASSIS

Built to take the grueling punishment of off-road hauling. High-strength ladder-type frame combines heavy-gauge channel siderails with alligator-jaw crossmembers. The net result is a solid chassis foundation with enough stamina to withstand the roughest terrain. Important features of the new 4-wheel drive chassis include front driving axle and driveshaft, dual master cylinder braking system with warning light and telescoping lower steering shaft with shear pin. To soak up bumps and control the ride precisely, double-acting shock absorbers are used for both front and rear wheels.

SINGLE-LEVER SHIFT CONTROL

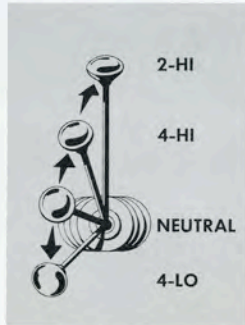

A convenient four-position shift control lever makes it easy to alternate between 2- and 4-wheel drive at any time. There's no need to use the clutch for this maneuver, even when the truck is moving. Shift positions are 4-wheel drive low gear (1.94 reduction), neutral, direct 4-wheel drive and 2-wheel drive.

TWO-SPEED TRANSFER CASE



Standard two-speed transfer case allows choice of high or low ranges in 4-wheel drive for more flexibility. A power takeoff opening makes it possible to operate a wide range of equipment using engine power. Transfer case is attached directly to transmission to maintain critical ground clearance.

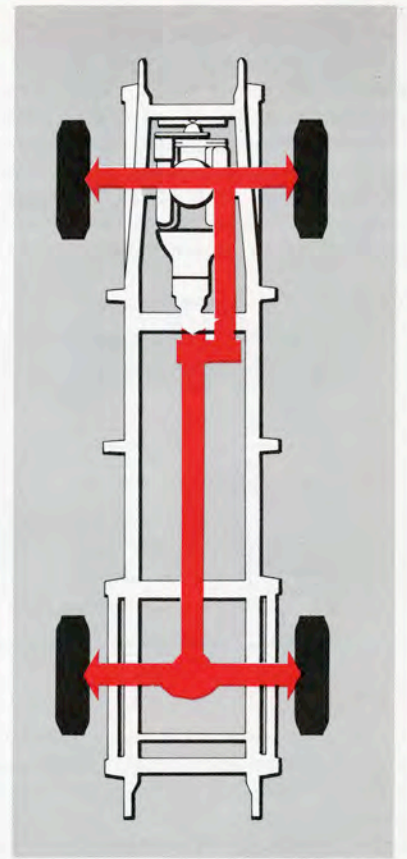

POPULAR 4 x 4 OPTIONS & ACCESSORIES

FREE-WHEELING HUBS

Available for all models, HUB/LOK front hubs are manually operated so that front wheels can be disengaged from the front driveline when 4-wheel drive is not being used. This free-wheeling feature eliminates unnecessary driveline wear and increases fuel economy on the highway.

POWER TAKEOFF

Utilize engine power to operate special equipment. A direct shaft-driven power takeoff can be attached to the opening provided in the transfer case. Ideal power source for hoists, winches, hydraulic snow plows, fluid pumps, electric generators, air compressors and other equipment.

CUSTOM SPORT TRUCK

Includes bucket seats, padded center console-type seat with folding armrest/backrest, carpeted floor and fuel tank, right-hand padded sunshade, chrome front bumper, bright-metal trim inside and out plus a distinctive CST emblem. Available for all 4-wheel drive pickups and chassis-cab models.

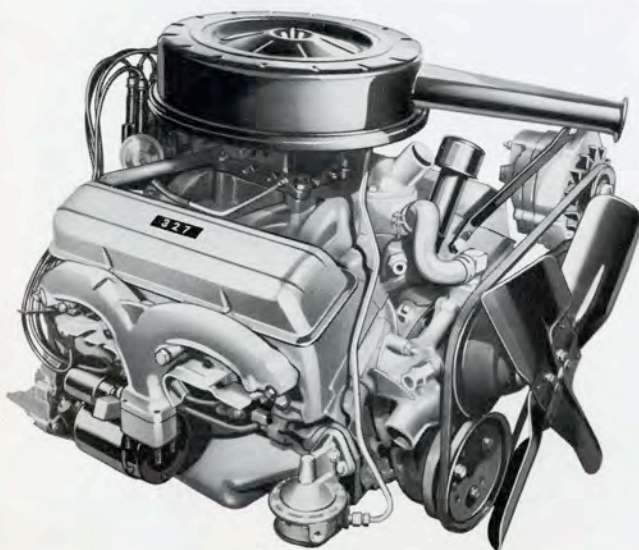

WIDER CHOICE OF HIGH TORQUE POWER

This year, for the first time, Chevy's husky 327 V8 is available on 4-wheel drive models. Just the ticket where maximum power is required. With two Sixes and two V8's in the Chevrolet 4 x 4 engine lineup, it's easier than ever to match the power to the job.

ENGINE SPECIFICATIONS

	250 Six	292 Six	283 V8	327 V8
Displacement (cu. in.)	250	292	283	327
Compression Ratio	8.5 to 1	8.0 to 1	9.0 to 1	8.5 to 1
Gross Horsepower @ rpm	155 @ 4200	170 @ 4000	175 @ 4600	220 @ 4400
Net Horsepower @ rpm	125 @ 3800	153 @ 3600	145 @ 4400	177 @ 4000
Gross Torque, lb.-ft. @ rpm	235 @ 1600	275 @ 1600	275 @ 2400	320 @ 2800
Net Torque, lb.-ft. @ rpm	220 @ 1600	255 @ 2400	240 @ 2400	283 @ 2400

SPECIFICATIONS

Series		K10 (½ Ton) 4-Wheel Drive		K20 (¾ Ton) 4-Wheel Drive	
GVW Ratings (lbs.)		5600		5700 to 7600	
Front Suspension		Standard	Optional	Standard	Optional
Axle-Type	—cap. (lbs.)	3300		3500	3500
	Ratios	3.73		4.55	
	—cap. (lbs.)	1450	1750	1600	1750
	Shock Absorbers	Standard	H.D. Opt.	Standard	H.D. Opt.
			Tubular Driving		
Rear Suspension		Semi-Floating		Full-Floating	
Axle—Type	—cap. (lbs.)	3300		5200	
	Ratios	3.73		4.57	
	Springs—Type	Tapered Leaf			
		1800		1900	2500
Engines		▲250 Six	●292 Six	▲250 Six	●292 Six
		▲▲283 V8	●●327 V8	▲▲283 V8	●●327 V8
	Clutch—dia. (in.)	▲ 10	11	▲ 10	11
	—area (sq. in.)	▲100	124	▲100	124
	—dia. (in.)	▲▲ 11	12	▲▲ 11	12
	—area (sq. in.)	▲▲124	150	▲▲124	150
			Manual		
Fuel Tank	—cap. (gal.)	21		21	
Transmissions		3-spd.	4-spd.	3-spd.	4-spd.
Transfer Case	Type	2-spd.		2-spd.	
Brakes	Type	Hydraulic	Power	Hydraulic	Power
Electrical	Battery	53 Amp.-Hr.	70 Amp.-Hr.	53 Amp.-Hr.	70 Amp.-Hr.
	Generator	37 Amp.	42, 61, 62	37 Amp.	42, 61, 62
Steering		Manual		Manual	
Wheels & Tires	Disc Wheels—Type	6-stud		8-stud	
	—rim width (in.)	5½	5.0, 5.25, 5.5	5.25	6.0
	Tubeless Tires—sizes	8.15-15	7.75-15	7-17.5	8-17.5
	—sizes		6.50-16		8-19.5
	—sizes		7-17.5		
	Tube-Type Tires—sizes		7.75-15		7.00-16
	—sizes		8.15-15		7.50-16
	—sizes		7.00-15		7.00-17
	—sizes		6.50-16		7.50-17

Equipment shown in red optional at extra cost.

▲Standard on 6-cylinder models.

▲▲Standard on V8 models.

●Optional on 6-cylinder models.

●●Optional on V8 models.

CHEVROLET NEW VEHICLE WARRANTY 1967 Model Series 10, 20, 30 Trucks and Chassis

There are no warranties, expressed or implied, made by either the selling dealer or Chevrolet Motor Division, General Motors Corporation, on new Chevrolet passenger cars, chassis, and 10, 20, 30 Series trucks except the warranty against defects in material or workmanship set out below:

Chevrolet Motor Division, General Motors Corporation, (hereinafter referred to as Chevrolet) warrants each new Chevrolet passenger car, chassis, and 10, 20, 30 Series truck (each being hereinafter referred to as a Vehicle) including all equipment and accessories thereon (except tires and tubes), manufactured or supplied by Chevrolet and delivered to the original retail purchaser by an authorized Chevrolet Dealer, to be free from defects in material or workmanship under normal use and service for 24 months or until it has been driven for 24,000 miles after such delivery, whichever occurs first; and further warrants the power train components specifically described as the cylinder block and head and all internal engine parts, intake manifold, transmission case and all internal parts, torque converter, propeller shaft and universal joints, differential, axle shafts and rear wheel bearings on any such Vehicle, manufactured or supplied by it to be free from defects in material and workmanship under normal use and service for 5 years or until it has been driven for 50,000 miles after such delivery, whichever occurs first.

As an express condition of this warranty, once every 6 months the owner is required to furnish an authorized Chevrolet Dealer evidence that the engine oil, oil filter, carburetor air filter, and positive crankcase ventilator valve (and automatic transmission oil and transmission band if so equipped) have been serviced in accordance with Chevrolet's required maintenance schedule as stated in the applicable Chevrolet Owner Protection Plan booklet, and have

the Dealer certify in such booklet (i) that he has received such evidence, and (ii) the then current indicated mileage on the odometer.

Chevrolet's obligation under this warranty is limited to repairing or replacing any part or parts which are returned to an authorized Chevrolet Dealer at such Dealer's place of business and which examination shall disclose to Chevrolet's reasonable satisfaction to have been thus defective. The repair or replacement of defective parts under this warranty will be made by such Dealer without charge for parts and labor. The provisions of this warranty shall not apply to any Vehicle which has been subject to misuse, negligence, alteration or accident, or which shall have been repaired outside of an authorized Chevrolet Dealer's place of business in any way so as, in the reasonable judgment of Chevrolet, to affect adversely its performance and reliability, nor to normal maintenance services (such as engine tune up, fuel system cleaning, carbon or sludge removal, brake and clutch adjustments and wheel alignment and balancing) and the replacement of service items (such as spark plugs, ignition points, positive crankcase ventilator valves, filters and brake and clutch lining) made in connection with such services, nor to normal deterioration of soft trim and appearance items due to wear and exposure.

This warranty is expressly in lieu of any other warranties, expressed or implied, including any implied warranty of merchantability or fitness for a particular purpose, and of any other obligations or liability on the part of Chevrolet, and Chevrolet neither assumes nor authorizes any other person to assume for it any other liability in connection with such Vehicle.