

**DODGE
BUILDS
TOUGH
PICKUP
TRUCKS**

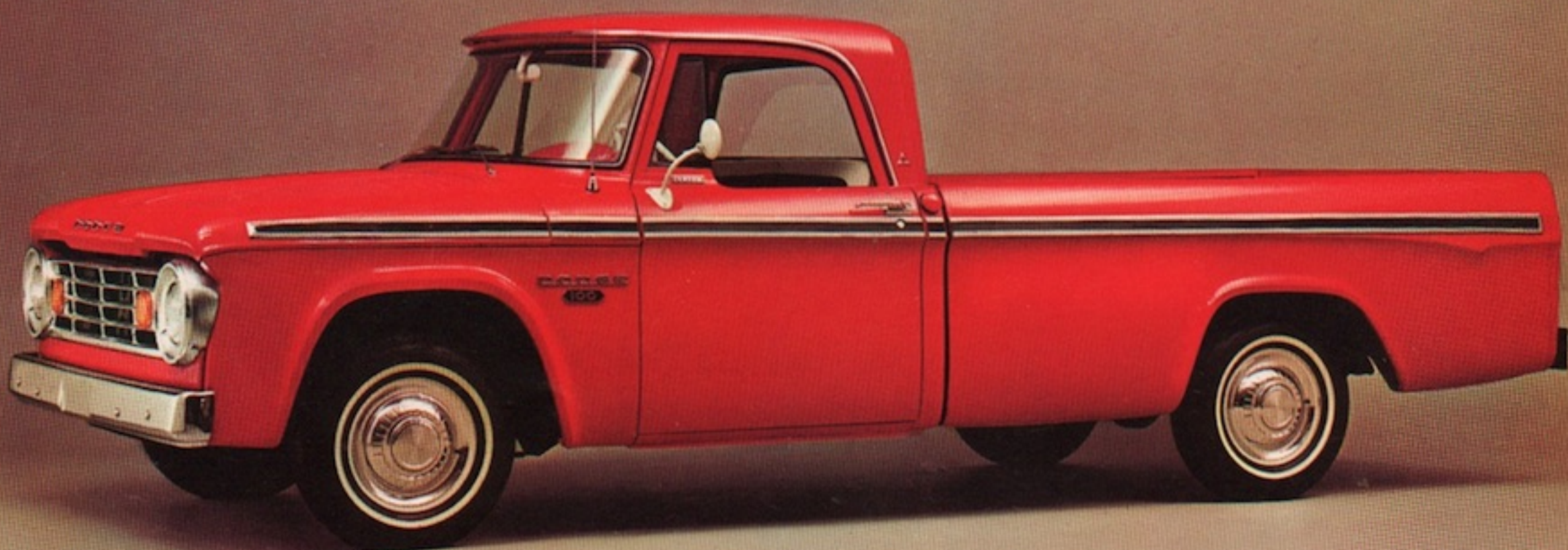

DODGE SWEPTLINE PICKUPS

Beautiful way to load up and light out. With a big, smooth, double-wall pickup box that's extremely easy to load. But what really makes Dodge the smartest buy in a pickup is the extra stamina Dodge puts into every truck component—in the cab, in the cargo box, in the engine, and in the suspension. Dodge simply builds tough, long-lasting pickups. And at competitive prices. (For proof of how tough, see the back cover of this catalog.) The good-looking Sweptlines shown here are available in two models on two wheelbases, with GVW's from 4300 to 7500 lbs. and payloads up to 3350 lbs.



D100 SWEPTLINE ON 128" WHEELBASE

STANDARD EQUIPMENT

- 140 hp, 225 cu. in. Dodge Slant Six engine
- Oil filter
- Closed crankcase ventilation
- 35-amp. alternator
- 3-speed synchro-shift transmission, column-mounted
- Self-adjusting brakes
- Front and rear Oriflow shock absorbers
- Painted front bumper
- Turn signals
- Dual painted exterior mirrors
- Dome light
- Coat hook
- Key lock on both doors
- 6-way adjustable seat
- Seat belts—2 pair
- Vinyl seat upholstery
- Driver's sun visor
- Rubber cab floor mat
- Driver-adjusted hand brake
- High-level ventilation
- Variable-speed electric windshield wipers with non-glare arms and blades
- Windshield washers
- Screw-type axle jack and wheel wrench
- Spare wheel and tire (D100)

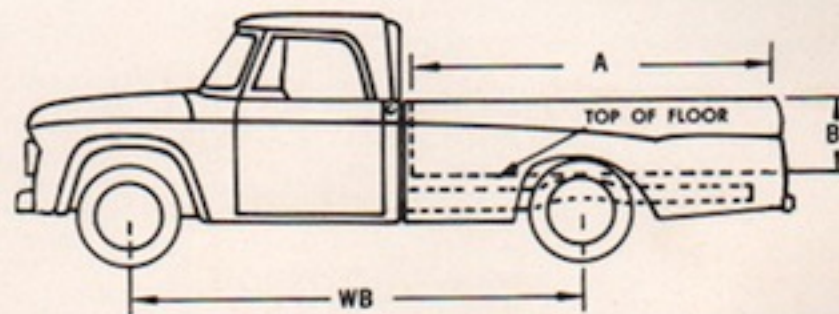

MODEL	D100	D200
Wheelbase (WB)	114"	128"
Nominal inside length	6½'	8'
Inside length (A)	78½"	98½"
Inside width (max.)	70"	70"
Width between wheelhousings	49"	49"
Height—top of sides and tailgate (B)	20"	20"
Capacity—(water level) cu. ft.	59.3	75
Stake pockets—size (inches)	2½ x 1½	2½ x 1½
—center to center, sides	74½"	51½"-43½"
—center to center, back	67½"	67½"

SWEPTLINE BOX FEATURES—Never has a pickup box had so many good ideas to make it so easy to load and so durable. And only Dodge has all these features. The sides of the Dodge Sweptline box have full-depth double-wall construction—not just two-thirds of the way up as on other double-wall pickups. You can bang, bruise and dent the entire inside of the box with no show on the outside. Dodge full-depth double wall also permits a one-piece outer skin, with no horizontal joints to collect rust and make the truck look old before its time. (It's shown below with the optional side trim moulding.) The floor on the Sweptline box is all-

steel. The wheel housings are flat on top to make them more practical for cargo space or as handy, out-of-the-way spots for toolboxes and such. The full-width tailgate (65 inches wide) stretches all the way out to the sides of the box. And it has an extra-sturdy latching mechanism that lets you open the gate or slam it shut with one hand. Hinged steel straps support the gate (not chains). And the straps can be unhooked to drop the gate completely when there's no rear bumper on the truck. Finally, Sweptline gives you a choice of two roomy bodies—a 6½-foot box with 59.3 cubic feet of cargo space or an 8-foot box with 75 cubic feet.



6½- OR 8-FOOT BOX WITH FULL-WIDTH TAILGATE



FULL DOUBLE-WALL CONSTRUCTION—ALL THE WAY UP

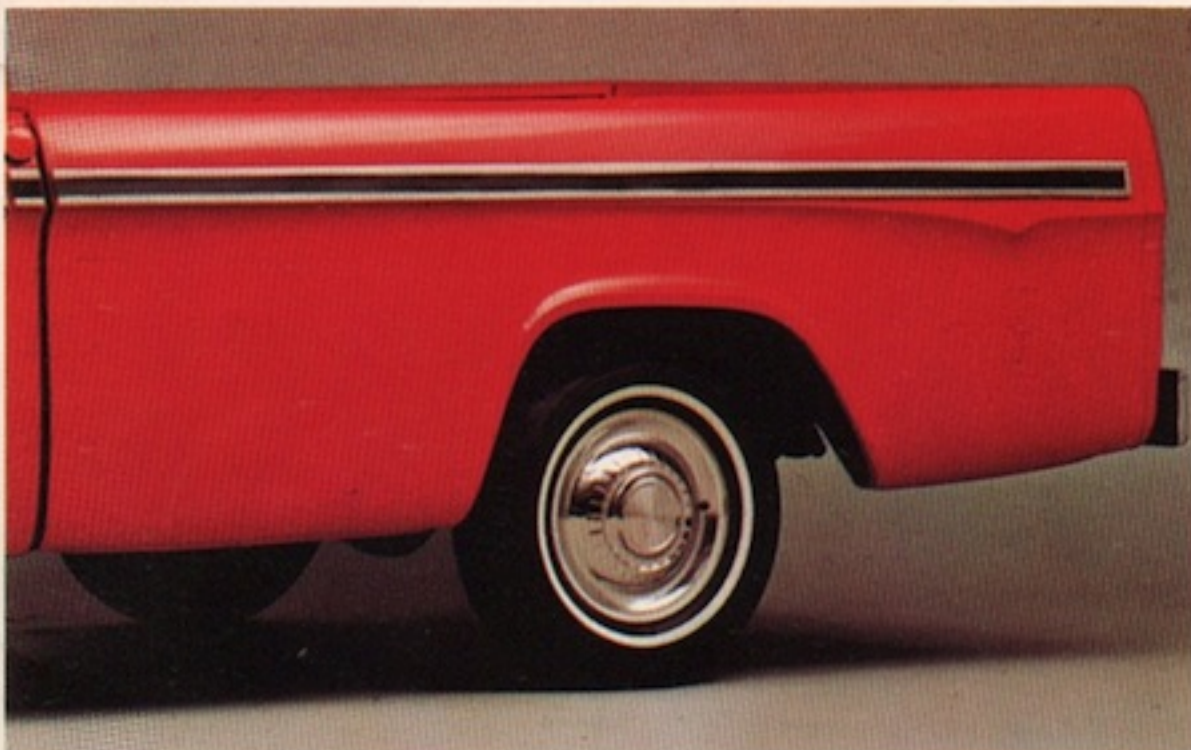

ONE-PIECE OUTER SKIN WITH NO RUST-COLLECTING POCKETS



ONE-HAND TAILGATE LATCH

DODGE UTILINE PICKUPS

Dodge Utilines put the pickup box between the rear wheels for a straight, unobstructed load space and to provide running boards outside the box for the easiest side loading. The box comes in three lengths, 6½-, 8-, or 9-feet, and has a seasoned hardwood floor with steel skids. GVW's run from 4300 lbs. all the way up to 10,000 lbs., with payloads up to 5645 lbs. Engine choices are the extra-tough, Dodge 140 hp Slant Six or optional Dodge 200 hp V8. D100 and D200 models have the same sturdy chassis components as the Sweptlines, including a drop-center frame that gives you a low-slung cab for easy ins and outs. The larger D300 Utiline has a straight truck frame, 4-speed transmission, and offers optional, extra-cost, dual rear wheels.



D100 UTILINE ON 114" WHEELBASE Dual painted exterior mirrors (not shown) are standard.

STANDARD EQUIPMENT

- 140 hp, 225 cu. in. Dodge Slant Six engine
- Oil filter
- Closed crankcase ventilation
- 35-amp. alternator
- 3-speed synchro-shift transmission (4-speed on D300)
- Self-adjusting brakes (D100, D200)
- Painted front bumper
- Turn signals
- Dual painted exterior mirrors
- Dome light
- Coat hook
- Key lock on both doors
- 6-way adjustable seat
- Seat belts—2 pair
- Vinyl seat upholstery
- Driver's sun visor
- Rubber cab floor mat
- Driver-adjusted hand brake
- High-level ventilation
- Variable-speed electric windshield wipers with non-glare arms and blades
- Windshield washers
- Screw-type axle jack and wheel wrench
- Spare wheel and tire (D100)

6½-, 8-, OR 9-FOOT BOX

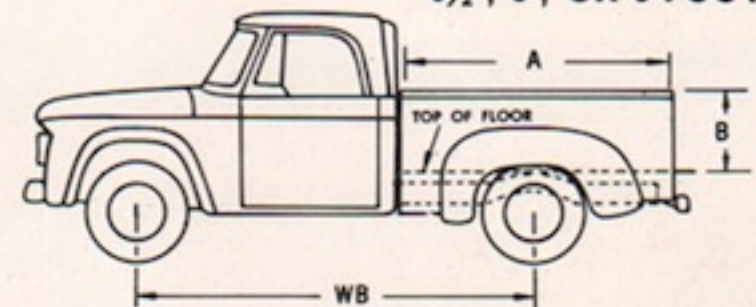

MODEL	D100	D200	D300	
Wheelbase (WB)	114"	128"	128"	133"
Nominal inside length	6½'	8'	8'	9'
Inside length (A)	78½"	96"	96"	108"
Inside width (max.)	54"	54"	54"	54"
Width between wheelhousings	49"	49"	49"	49"
Height—top of sides and tailgate (B)	20"	20"	20"	20"
Capacity—(water level) cu. ft.	47.25	58.5	58.5	66.0
Stake pockets—size (ins.)	2½ x 1½	2½ x 1½	2½ x 1½	2½ x 1½
—center to center, sides	74½"	92½"	92½"	57"—50½"
—center to center, back	57½"	57½"	57½"	57½"

SWEPTLINE AND UTILINE CAB FEATURES

You get more comfort, more durability from a Dodge pickup because Dodge puts more into its cab. The seat, for example, is adjustable six ways to perfectly fit the driver. It's built like a premium seat, too, has an extra-strong frame and forty-eight, tough, coil springs. And if you'd like to add even more comfort or a dressier look to the cab, Dodge offers a complete range of cab options at extra cost, including the packages shown below.



STANDARD CAB—Roomy. Comfortable. Easy to live with. And that handsome, black-and-white vinyl upholstery is standard. Also standard are seat belts for driver and passenger, driver's sun visor, dome light, ashtray, dispatch box, key lock on both doors, coat hook, rubber floor mat, high-level ventilation, and an adjustable Orscheln-lever hand brake.



OPTIONAL COMFORT PACKAGE—Adds to the standard cab: a full-depth foam rubber seat and foam-padded seatback, fabric and vinyl seat upholstery, driver's armrest, right sun visor, cigar lighter, and extra cab insulation. The breathable fabric lets air circulate for cool comfort. Available in red, beige, or blue-green, depending on the truck color.



OPTIONAL APPEARANCE PACKAGE—A dress-up package for both the outside and inside of the cab. Outside, it includes a chrome grille, bright drip mouldings, and mylar trim around the windshield and rear window, plus "Custom" nameplates and delta emblems on the cab. Inside the cab, it adds a bright-metal "face" to the instrument cluster and around the control knobs, a bright-finish dashboard moulding, plus textured metal trim panels on the doors. D100 and D200 models also include a white steering wheel and chrome horn ring with this low extra-cost package.

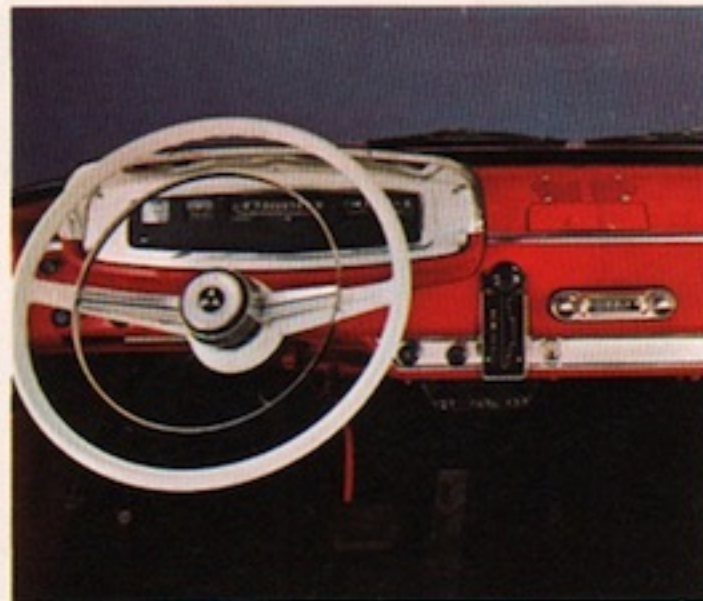

OPTIONAL SWEPTLINE SIDE MOULDING—Adds a bolder, more distinctive look to the sides of Sweptline pickups. Full-length, bright-metal moulding is filled with your choice of white or black paint, with any truck color. (Not available on Crew Cabs or Utilines.)

CUSTOM SPORTS SPECIAL

We created this one as a real bomb for racing enthusiasts. But regular truck buyers latched onto it right away. Because it is so sporty. And still a true worker. Inside, you get bucket seats, fully carpeted floor, between-the-seats console, and other niceties. Outside, it has chrome grille, bumper, and roof mouldings—plus a set of racing stripes over the roof and hood. It's available as a D100 or D200 Sweptline, Utiline, Stake, or Chassis-Cab (or W100, W200 4-wheel-drive). Engine choices are the standard 140 hp Slant Six or optional 200 hp 318 V8—or, optional on D100, D200 models only, the famous Dodge 426 V8 that churns out a hot 365 horsepower.



- | | | | |
|--|---|---|---|
| <ul style="list-style-type: none"> • Black vinyl bucket seats with seat belts • Fully carpeted cab floor • Center console with cigarette lighter, ash-tray, courtesy map light, storage compartment | <ul style="list-style-type: none"> • Chrome grille, bumper, roof mouldings • Racing stripes on roof and hood • White steering wheel with chrome horn ring (D100, D200) | <ul style="list-style-type: none"> • Bright instrument panel trim • Mylar trim around windshield and rear window • Custom nameplates, delta emblems on cab | <p>STANDARD EQUIPMENT</p> <ul style="list-style-type: none"> • Dual armrests and sun visors • 140 hp, 225 cu. in. Dodge Slant Six engine • 3-speed synchro-shift transmission, column-mounted |
|--|---|---|---|

OTHER DODGE PICKUPS



A100 COMPACT—If a compact pickup is your meat, get the first compact with real truck toughness, the Dodge A100. Has a 7-foot pickup box. Available with Six or V8 power. See Dodge Compact Truck Catalog.



CREW CAB—Carries six big workmen up front and a 6½-foot pickup box in back. Dodge Crew Cab pickups are factory production models to save you money. See Dodge Crew Cab Catalog.



4-WHEEL-DRIVE—Dodge was a pioneer in 4-wheel-drive trucks. And its six 4 x 4 pickups are specially designed from the ground up for sticky spots. They're covered in the Dodge 4-Wheel-Drive Catalog.

DODGE CAMPER SPECIAL

Because Dodge pickups and chassis-cabs are built for rugged service, they make ideal mates for camper installations. The 128-inch wheelbase on D100 and D200 models gives you excellent weight distribution with a camper aboard. The wide 65-inch tailgate opening on Sweptlines accommodates virtually all camper bodies. World-famous Dodge 4-wheel-drive models give you off-the-road mobility. And Dodge Crew Cab pickups let you carry the entire family up front. Wide selection of models. Dodge's well-proved toughness. Great combination for plunging in and out of the wildest places.



CAMPER SPECIAL MODELS—Dodge offers you eight pickups specially engineered for the heavy weight of a slide-on camper coach. Each Camper Special adds to the standard equipment of the pickup the items that really count for safety, good handling characteristics, and the best overall economy. All you need to select are the right power team and the right wheels and tires for the weight of your camper.

DODGE PICKUP TRUCK MODEL	D100	D200	D200 Crew Cab	W200
• Wheelbase	128"	128"	160"†	128"
• Sweptline or Utiline box	8'	8'	8'†	8'
• Camper body size	8'	Up to 10' Cab-Over	Up to 10' Cab-Over	Up to 10' Cab-Over
• Maximum weight—(camper body, driver, passengers and gear)	1200 lbs.	3100 lbs.	3100 lbs.	3100 lbs.
REQUIRED MINIMUM EQUIPMENT (not included in Camper Special)				
• Engine model and clutch size 8' Camper body	225—11"	225—11"	225—11"	225—11"
10' Camper body	Not Recommended	318—11"	318—11"	318—11"
• Transmission	3-speed	4-speed or LoadFlite	4-speed or LoadFlite	4-speed
• Tires—front, single rear and spare —front and single rear	6.50 x 16 6PR —	— 7.50 x 16 8PR	— 7.50 x 16 8PR	— 7.50 x 16 8PR
• Wheels—five	16 x 4.50	16 x 5.50	16 x 5.50	16 x 5.50

BASIC CAMPER SPECIAL (for all models in chart above)

- 59-amp. alternator
 - 70-amp.-hour battery
 - Power brakes (except D100)
 - Increased cooling
 - Oil pressure gauge
 - Dual western-type, bright finish mirrors
 - Front springs (at pad)
1250 lbs. (D100)
1500 lbs. (D200, D200 Crew Cab)
1550 lbs. (W200)
 - Rear springs (at pad)
1750 lbs. (D100)
2600 lbs. (D200, W200)
3125 lbs. with auxiliary
(D200 Crew Cab)
 - "Camper Special" emblems
- †Camper Special for D200 Crew Cab also includes special 160" wheelbase and 8' box.

DELUXE CAMPER PACKAGE

(for all models in chart above)
Camper Special plus the following equipment:

- Comfort Package
- Heater-defroster (Custom Fresh Air)
- Traffic hazard warning switch
- Dual electric horns

CUSTOM CAMPER PACKAGE

(for Sweptlines only in chart above)
Deluxe Camper Package plus the following equipment:

- Appearance Package (on Crew Cab does not include bright drip mouldings or textured door trim panels)
- Exterior side moulding (except Crew Cab)
- Chrome front bumper (except W200)

DODGE OPTIONS AND ACCESSORIES

You'll find your Dodge pickup well-suited to the job just as it is. However, in case you'd like to add to your truck's performance and convenience, a complete range of optional, extra-cost equipment and accessories is available. Some of these items are shown here (in addition to the cab packages on Page 5). There are many more to choose from. For the complete list of options, see your Dodge Truck dealer.

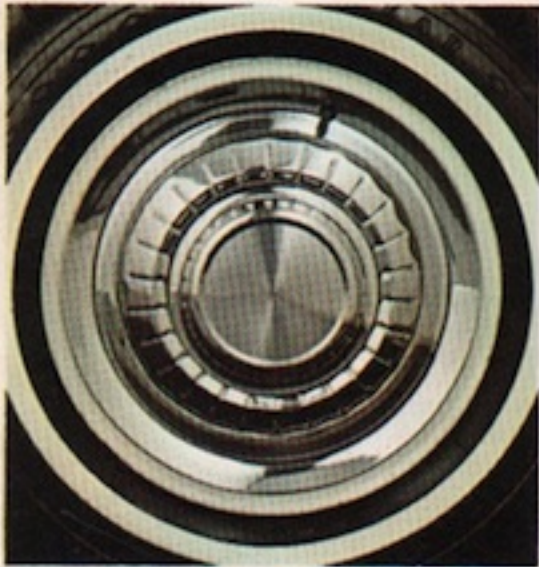

WHEEL COVERS



POWER BRAKES

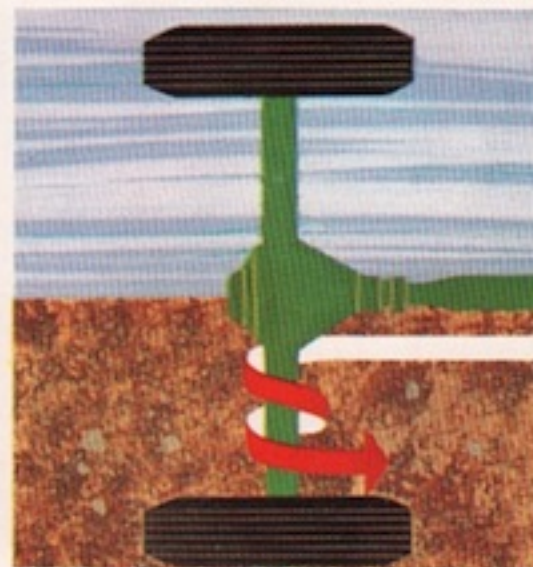

ANTI-SPIN DIFFERENTIAL



POWER STEERING



TRANSISTOR RADIO



HEATER-DEFROSTER

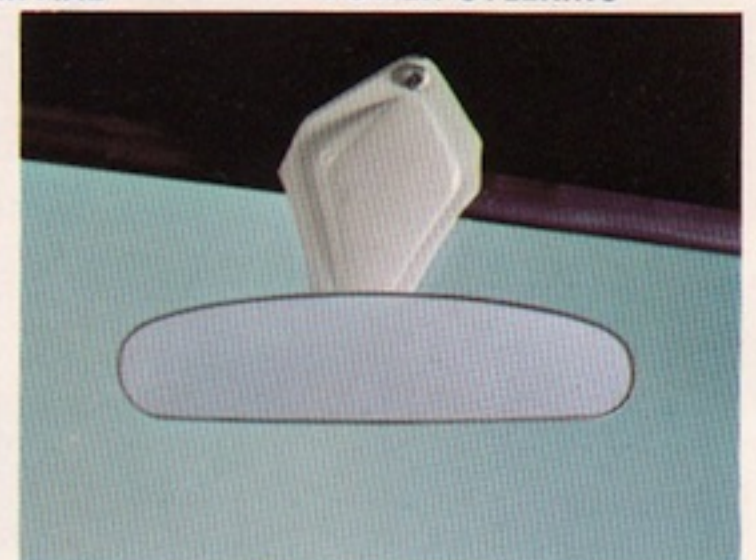

INSIDE REAR VIEW MIRROR

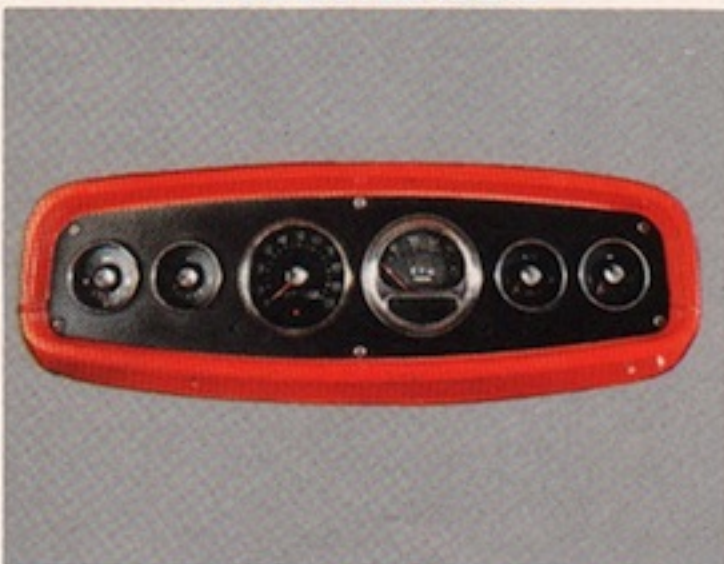

HEAVY-DUTY INSTRUMENT CLUSTER



CHROME FRONT OR REAR BUMPER



FULL-WIDTH REAR WINDOW

Other options include dual braced exterior mirrors (shown at right) plus:

- 1 QUART OIL BATH AIR CLEANER
- 46-AMP. OR 59-AMP. ALTERNATOR
- 70-AMP.-HOUR BATTERY
- FULL-DEPTH FOAM SEAT IN STANDARD CAB
- DUAL ELECTRIC HORNS
- OIL PRESSURE GAUGE
- TRAFFIC HAZARD WARNING SWITCH
- TINTED GLASS—WINDSHIELD AND REAR WINDOW
- HYDRAULIC JACK (3-TON)
- TWO-TONE PAINT
- UNDERCOATING
- SPARE TIRE (STD. ON D100)



LONG ARM ADJUSTABLE BRACED
—5" x 7" HEAD

ENGINES AND TRANSMISSIONS

Other pickup truck engines may give you as much power as Dodge, but few give you as much toughness. The crankshaft, for example, on all Dodge pickup engines is the same type used on the big trucks—a drop-forged crankshaft that's much stronger than the cast crankshaft found in some pickup engines. All Dodge power plants reach their maximum torque or pulling power at low rpm's for less wear and tear. And Dodge engines are just as easy on fuel and maintenance costs, making them the smartest buys for the hard work you expect from a pickup.

Engines illustrated have been painted and chrome-plated for display purposes.

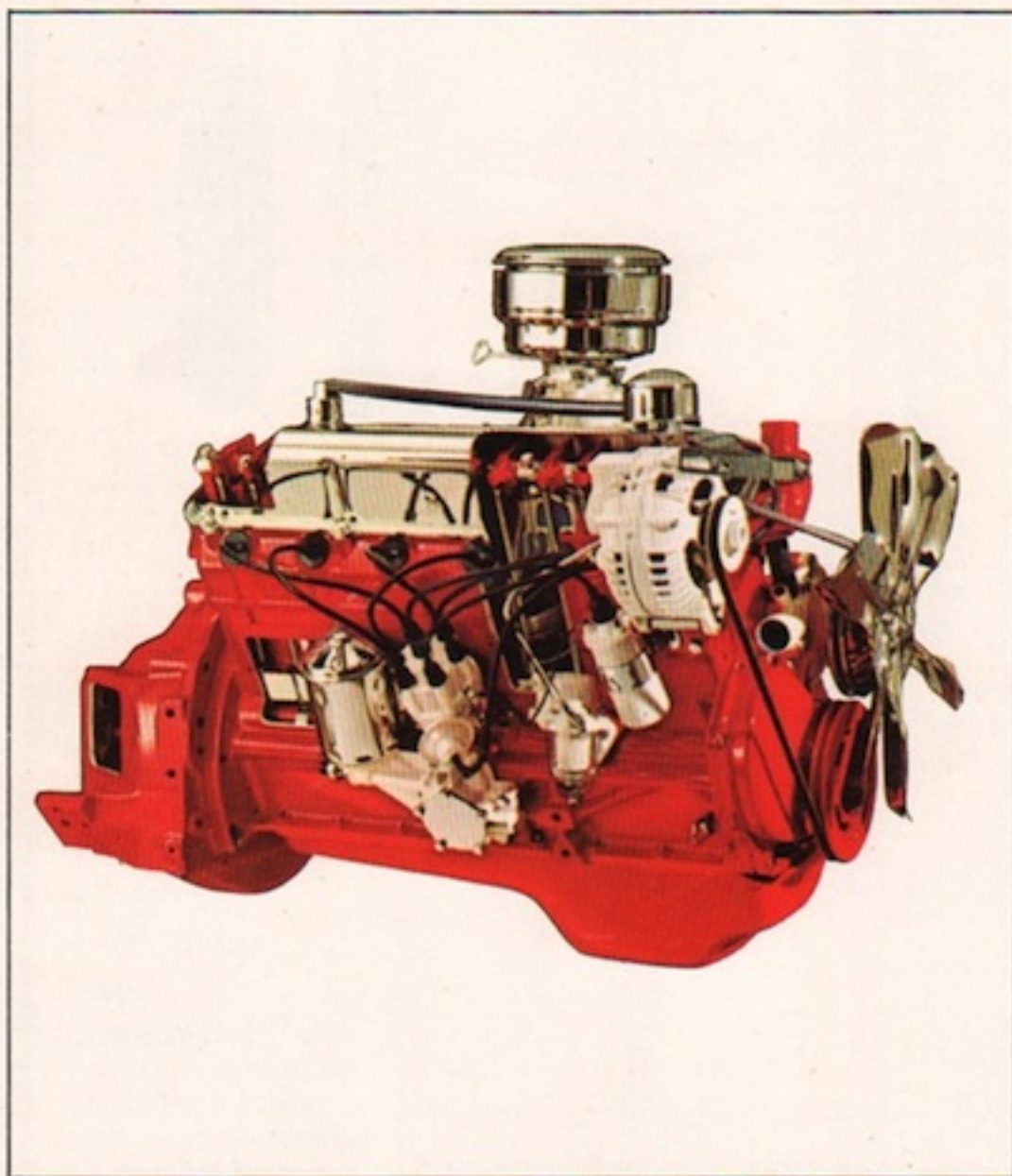

STANDARD 140 HP SLANT SIX 225. Highly efficient. Easy to service. Inclined at 30-degree angle for low center of gravity and individually ported, long-branch manifolds for superb engine "breathing." Features drop-forged crankshaft, weight-saving aluminum parts, deep-skirt block, rugged valve train, large radiator, and replaceable oil filter element.

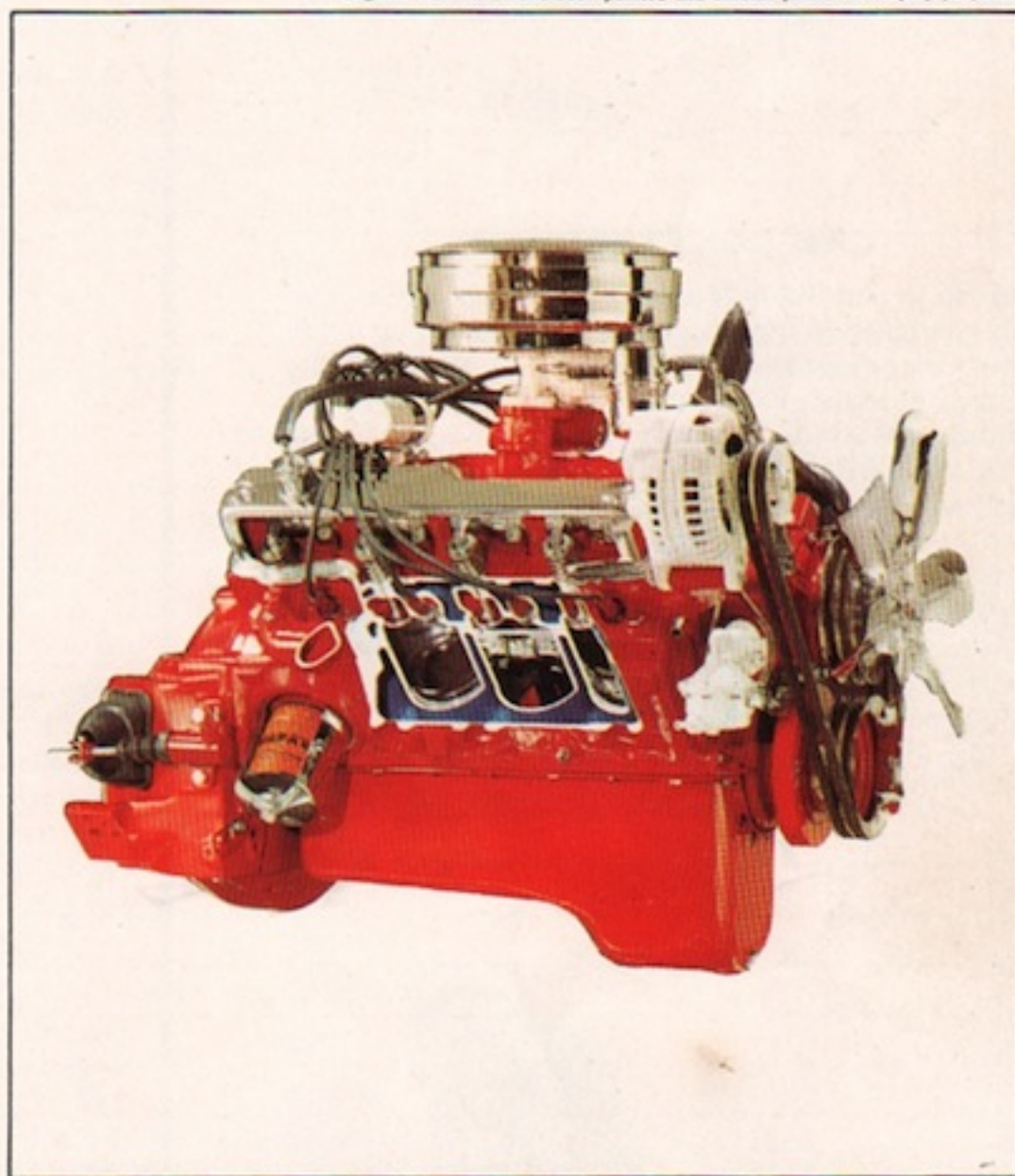

OPTIONAL 200 HP 318 V8. Husky Dodge V8 with all the pep and pulling power you'd want. Big 318 cubic inch displacement. 8.25:1 compression ratio. Its premium features include a drop-forged crankshaft, free-turning exhaust valves, drop-forged I-beam connecting rods, rotary-type oil pump, oil filter element, and silent-chain camshaft drive.



3-SPEED SYNCHRO-SHIFT, HEAVY-DUTY. Standard on D100 and D200. A true heavy-duty truck transmission with an unusually low 3.02 first-gear ratio for quick, easy starts.



4-SPEED SYNCHRO-SHIFT, EXTRA-HEAVY-DUTY. Standard on D300. Optional on D100 and D200 with close-spaced ratio. Exceptionally rugged. Has extra-large components for high capacity and long life.

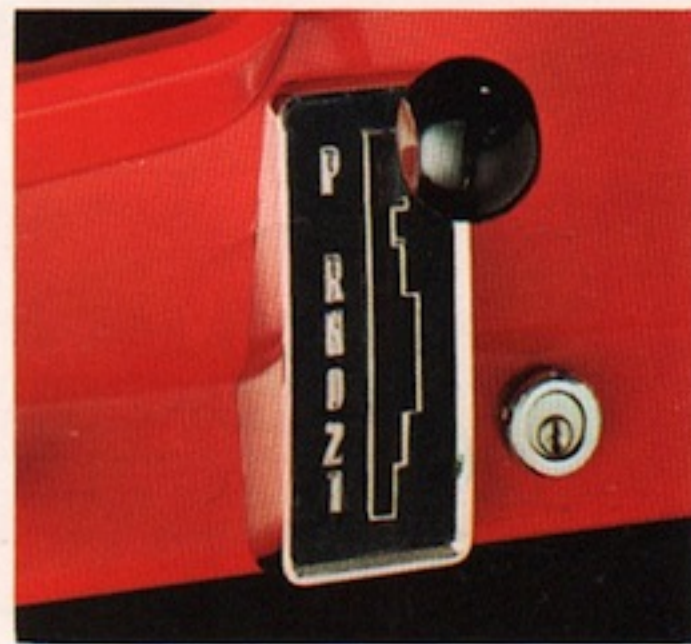

LOADFLITE 3-SPEED AUTOMATIC. Optional on all models. Tops in torque multiplication for starting. Highly efficient because its intermediate range provides an easy transition between low and direct drive.

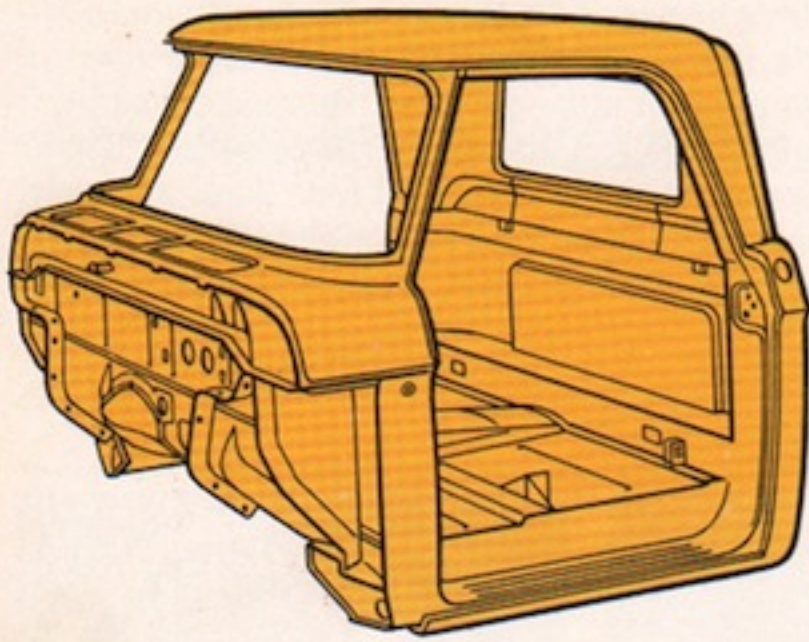

CAB CONSTRUCTION

Climb in and out of it a thousand times a year. Pile up the miles in it over all kinds of roads. You'll find the Dodge conventional cab just as tough as the rest of the truck. That's because of the extra details Dodge puts into it. Things like the solid, all-welded construction with box-section beams in the sills, pillars, cowl, roof rails, and the back of the cab. Or the big, husky door hinges with thick reinforcements that protrude deep into the doors. Or the extensive rustproofing applied to all critical areas. Or the thick rubber mounts that cushion the cab on the chassis. They all add up to one of the toughest and tightest cabs in the business.

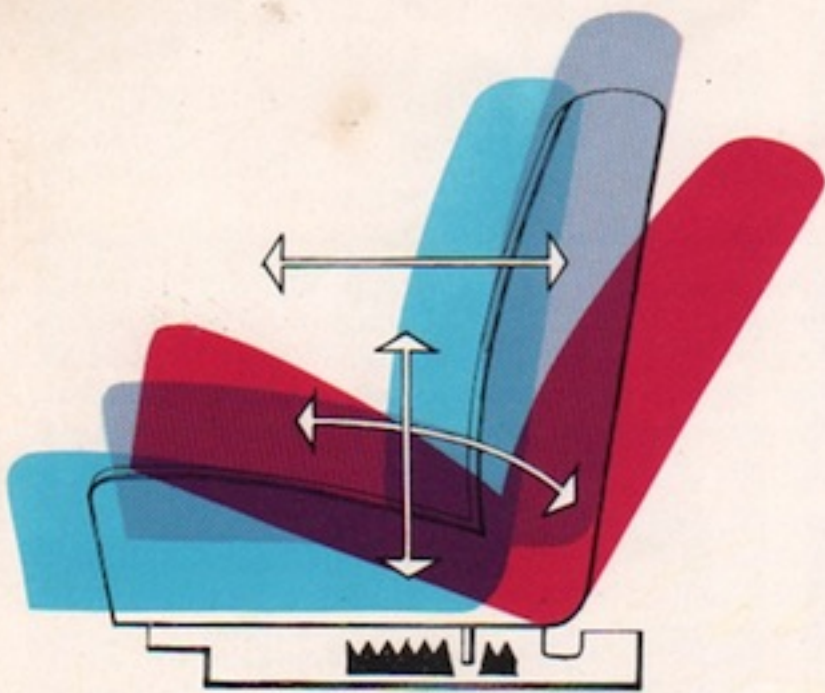

SIX-WAY ADJUSTABLE SEAT

Another area where you get more in a Dodge is in the seat. It's extremely durable. Keeps its shape. (The standard seat has an extra-thick frame and 48 tough coil springs topped by cotton and foam pads.) The seat is adjustable six ways to custom-fit any driver. The fore-and-aft adjustment range of the seat on the track is, first of all, a full five inches—more than on any other truck. In addition, a special regulator at each end of the seat gives you one inch of vertical adjustment and lets you tilt the seat forward or backward. These last two adjustments can be quickly and easily made with nothing more than a hand wrench.

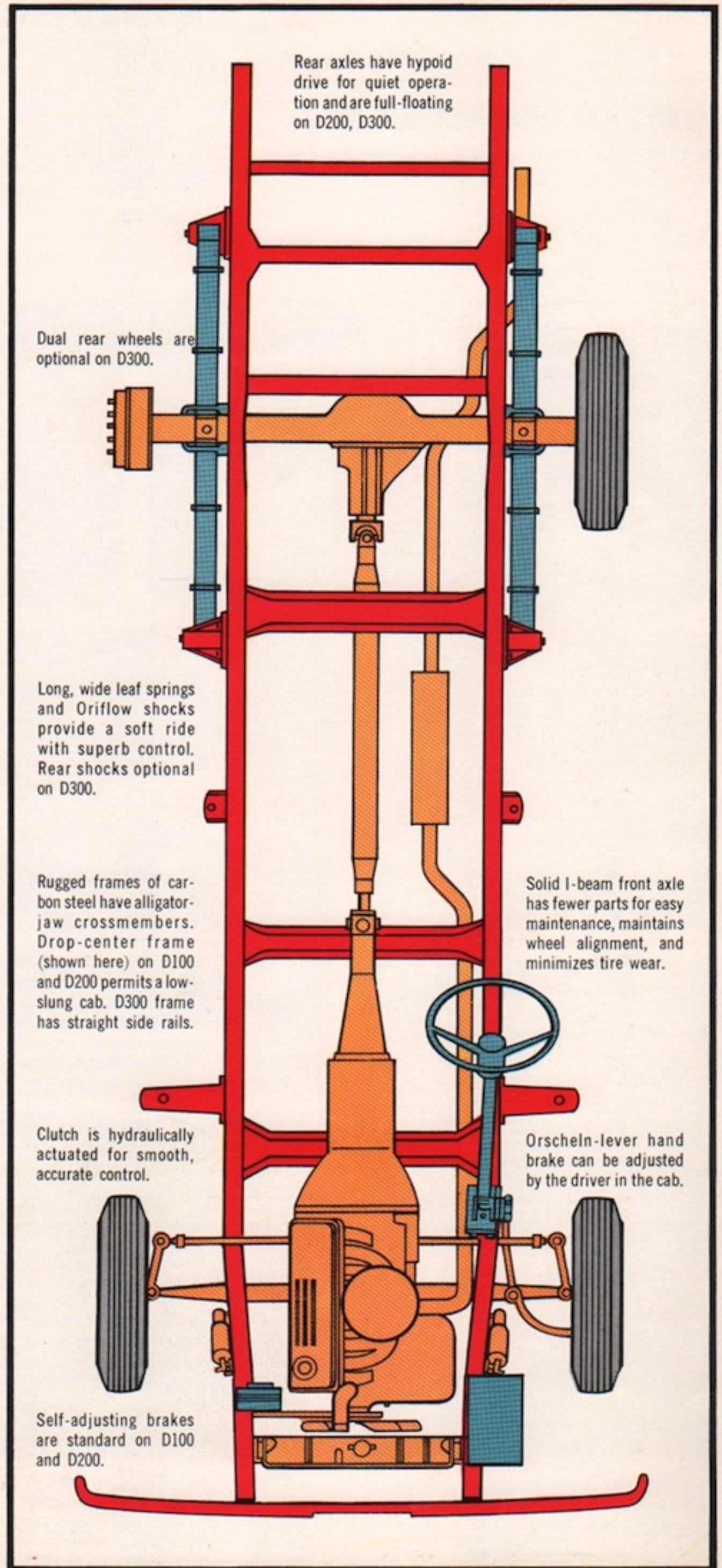

SPECIFICATIONS

	D100	D200	D300
GVW Ratings	4,300-5,200 Lbs.	5,200-7,500 Lbs.	6,300-10,000 Lbs.
Payload Allowance	715-1,695 Lbs.	1,330-3,350 Lbs.	2,115- 5,645 Lbs.
Air Cleaner	1 Pint Oil Bath (6-Cyl.) Dry Paper Element (V8), (1 Quart Oil Bath, Extra, 6-Cyl. & V8)		
Alternator—Std. (Extra)	12-Volt, 35-Amp. (46-Amp. or 59-Amp.)		
Axle, Front	I-Beam		
Capacity	2,500 Lbs.	2,800 Lbs.	3,800 Lbs.
Axle, Rear	Single-Speed Semifloating, Hypoid	Single-Speed Full-Floating, Hypoid	
Capacity	3,600 Lbs. (1)	5,500 Lbs. (1)	7,500 Lbs. (1)
Ratios (to 1)	3.23, 3.55, 3.91 (1)	3.54, 4.1 (1), 4.88	4.1, 4.88 (1), 5.87 (2)
Battery	12-Volt—53-Amp.-Hour		
Brakes, Service	Hydraulic (Self-Adjusting D100, D200)		
Size—Front	11" x 2.25"	12.12" x 2"	12.12" x 2"
—Rear	11" x 2"	12.12" x 2"	13" x 2.5"
Total Lining Area—Sq. In.	196.8	211.6	240.1
Brakes, Parking	Rear Wheels, Driver-Adjustable		Transmission-Mounted, Driver-Adjustable
Size	95.4 Sq. In.	105.8 Sq. In.	7" x 2" (LoadFlite Trans.) 8" x 2.5" (NP435 Trans.)
Brakes, Power—Extra Size	None —	Vacuum 8"	
Clutch	Single-Plate, Dry Disc		
Diameter and Area	10"—90.7 Sq. In. (6-Cyl.), 11"—123.7 Sq. In. (V8) (6-Cyl., Extra)		11"—123.7 Sq. In.
Cooling System—Capacity	13 Qts. (6-Cyl.), 20 Qts. (V8)		
Engines—6-Cyl.—Std.	140 HP, 225		
—V8—Extra	200 HP, 318		
Frame	Drop-Center		Straight
Section Modulus	2.56 (114" WB) 3.88 (128" WB)	3.88	5.70
Fuel Tank—Capacity	18 Gallons		
Location	Inside Cab, Behind Seat		
Shock Absorbers	Oriflow		
	Front and Rear		Front Only
Springs, Front—Capacity (at Pad)—Std.	1,025 Lbs.	1,025 Lbs.	1,250 Lbs.
—Extra	1,250 Lbs.	1,250 Lbs.	1,500 Lbs.
Springs, Rear—Capacity (at Pad)—Std.	1,100 Lbs.	1,500 Lbs.	2,050 Lbs.
—Extra	1,400 Lbs., 1,750 Lbs.	1,950 Lbs., 2,600 Lbs.	3,000 Lbs., 3,600 Lbs.
Steering Power Steering	Recirculating Ball Available as Extra Equipment with V8		
Transmission—Std.	3-Spd. Syn. (A745)	3-Spd. Syn. (A745)	4-Spd. Syn. (NP435)
—Extra	4-Spd. Syn. (NP435) (3)	4-Spd. Syn. (NP435) (3)	
Automatic—Extra	3-Spd. LoadFlite	3-Spd. LoadFlite	3-Spd. LoadFlite
Tires	Tubeless		
Std.—Front and Single Rear	6.70-15-4	6.50-16-6	8-17.5-6
Max. Available—Front and Single Rear	6.50-16-6	8-19.5-8	8-19.5-8
—Front and Dual Rear	—	—	8-17.5-8
Wheels and Rims—No. and Type	5, 5-Stud Disc	5, 8-Stud Disc	5, 6-Stud Disc
Windshield Wipers—Std.	Dual Electric, Variable-Speed		

(1) Anti-spin differential available.

(2) 5.87 ratio N.A. w/wide tread dual wheel axle.

(3) Close-spaced ratio.

ENGINES

	225 SLANT SIX STANDARD	318 V8 OPTIONAL
Bore and Stroke (In.)	3.40 x 4.125	3.91 x 3.312
Displacement (Cu. In.)	224.7	318.14
Maximum Horsepower	140 @ 3900 RPM	200 @ 3900 RPM
Maximum Torque (Lbs./Ft.)	215 @ 1600 RPM	286 @ 2400 RPM
Compression Ratio (to 1)	8.4	8.25
Carburetor	1-Barrel	2-Barrel



FROM COMPACTS TO DIESEL POWER
Dodge Builds Tough Trucks

**DODGE
 TRUCK
 5-YEAR/
 50,000-MILE
 ENGINE AND DRIVE TRAIN
 WARRANTY**

HERE'S HOW THIS WARRANTY COVERAGE PROTECTS YOU:

Chrysler Corporation warrants for 5 years or 50,000 miles or 1500 hours of operation, whichever comes first, against defects in materials and workmanship and will replace or repair at a Chrysler Motors Corporation authorized dealer's place of business gasoline and Perkins diesel engines (i.e., block, heads, and internal parts), intake manifold, water pump, flywheel, flywheel housing, clutch housing, torque converter, transmission (i.e., case and internal parts, excluding manual clutch), transfer case and all internal parts, drive shafts, center bearings, universal joints, driving axles and differentials, and drive wheel bearings of its new Dodge trucks, provided the owner has (1) the engine oil changed and universal joints (except sealed-type) lubricated and the oil-bath-type carburetor air filter cleaned every 3 months or 4000 miles (every 2 months or 2000 miles on models 400 through 1000), whichever comes first, (2) the engine oil filter replaced and dry-type carburetor air filter cleaned every second oil change, and dry-type carburetor air filter element replaced every 24,000 miles, (3) the crankcase ventilation system cleaned and serviced every 4000 miles, and (4) the transmission, transfer case and driving axle lubricants changed every 32,000 miles (every 20,000 miles on models 400 through 1000). The foregoing services must be performed more often when reasonably required due to severe dust or regular "stop and go" operation. Every 6 months the owner must furnish to such a dealer evidence of performance of the required service and request the dealer to certify (1) receipt of such evidence and (2) the truck's then current mileage.

Chrysler Corporation's warranty against defects in materials and workmanship on gasoline engines of 800, 900, and 1000 series new Dodge trucks is for 5 years, 100,000 miles or 3000 hours of operation, whichever comes first, and provides for repairing or replacing parts at a Chrysler Motors Corporation authorized dealer's place of business at no charge for parts and after 50,000 miles or 1500 hours of operation, at a prorated labor charge based on 25% up to 60,000 miles or 1800 hours of operation, 50% up to 75,000 miles or 2250 hours of operation, and 75% up to 100,000 miles or 3000 hours of operation, in each instance whichever comes first. This warranty covers the engine (i.e., block, heads and all internal parts), intake and exhaust manifolds, timing gears, water pump, flywheel, flywheel housing and clutch housing, provided the engine maintenance services required are performed and certified as specified above.

**DODGE
 TRUCK
 5-YEAR/
 100,000-MILE
 HEAVY-DUTY GASOLINE ENGINE
 WARRANTY**

*Colonial Dodge
 2323 34th St. No.*

Dodge Builds Tough Trucks

DODGE DIVISION  CHRYSLER
 MOTORS CORPORATION

Tom Smith

Equipment listed as "optional" or "extra" is extra-cost equipment. Although all descriptions and pictorial representations of the trucks in this catalog are believed to be correct at time of publication, accuracy cannot be guaranteed. The policy of Dodge Truck is one of continual improvement; therefore, equipment, colors, materials and other specifications, model availability and prices are subject to change without notice or obligation. DODGE PICKUP CATALOG. Litho in U.S.A. 7/65. Rev. 81-305-5100.