

THIS IS THE EDSEL

Newest Expression of Fine Engineering from Ford Motor Company

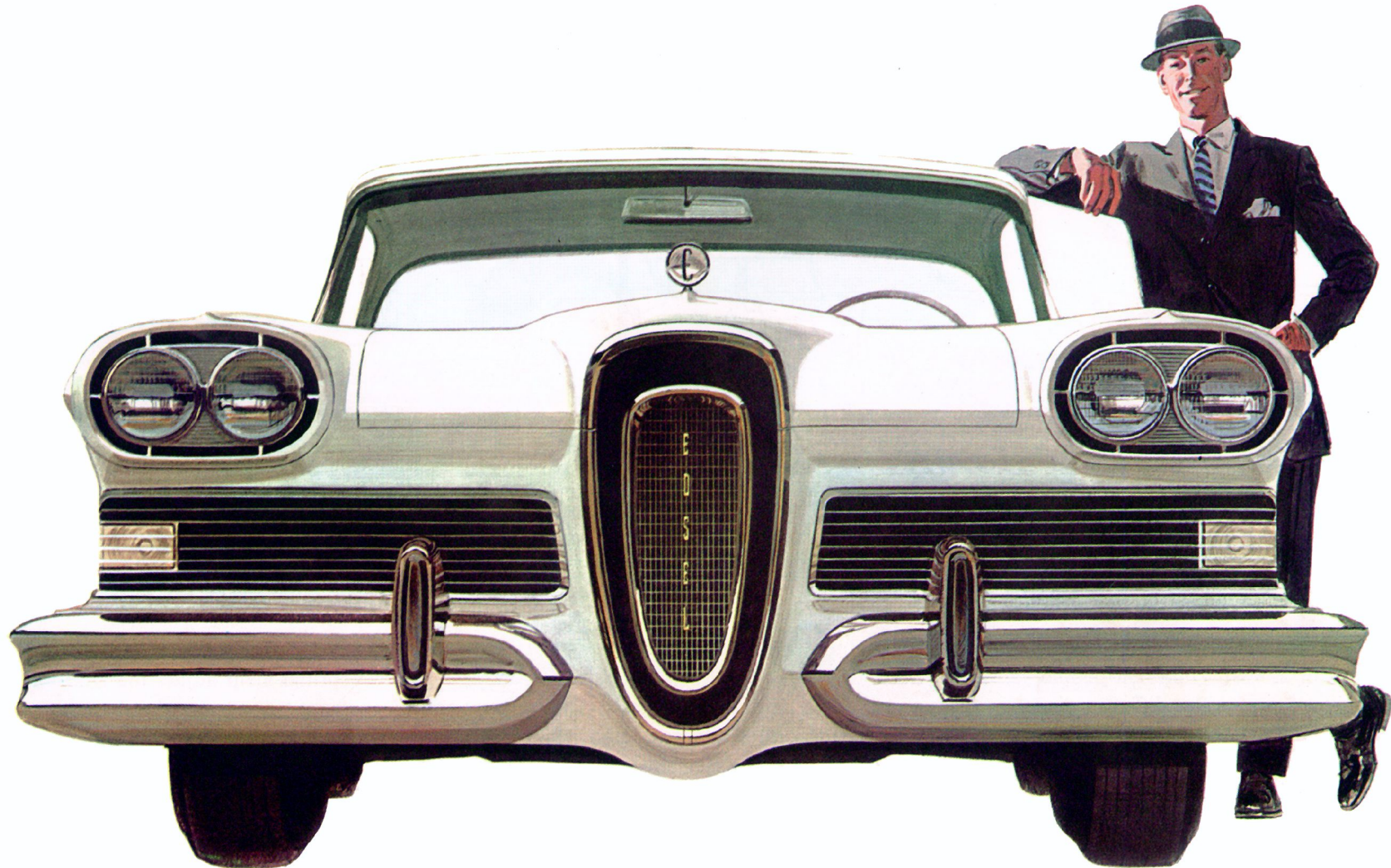

EDSEL TELETOUCH DRIVE

EDSEL ENGINES

YOU CAN TELL A BLOCK AWAY THIS IS NO ORDINARY CAR

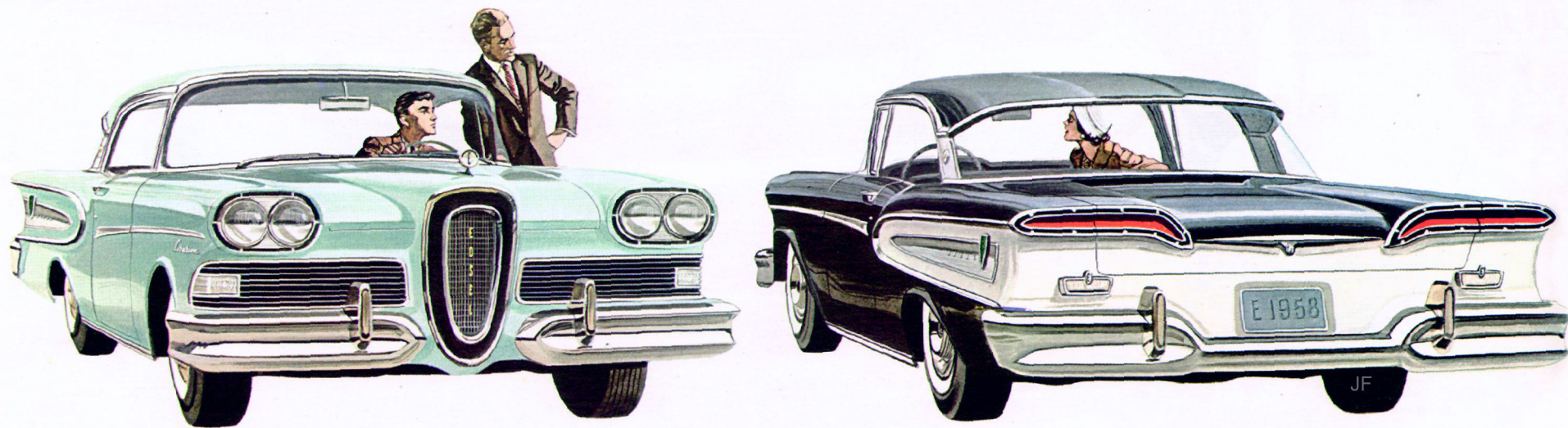

CITATION

PACER

STATION WAGONS

EDSEL FEATURES

EDSEL CHASSIS

This is the Edsel and there has never been a car like it. Originality is clearly written in the elegance of its every line—from its bold vertical grille to the sweep of its low, wide flight deck.

The Edsel is the result of eleven years of planning and testing. Indeed, no new car has ever had such a proved background—for example, more than 1,250,000 road-test miles alone. Concentrated in the Edsel

is more than a half century of manufacturing and engineering experience of Ford Motor Company. But to really know how completely its designers have spurned the commonplace, you must drive it.

When you do, you will know why Ford Motor Company has proudly named it after Edsel Ford, the son of its founder. In all its fresh, new beauty and all its advanced engineering, *this is the Edsel!*

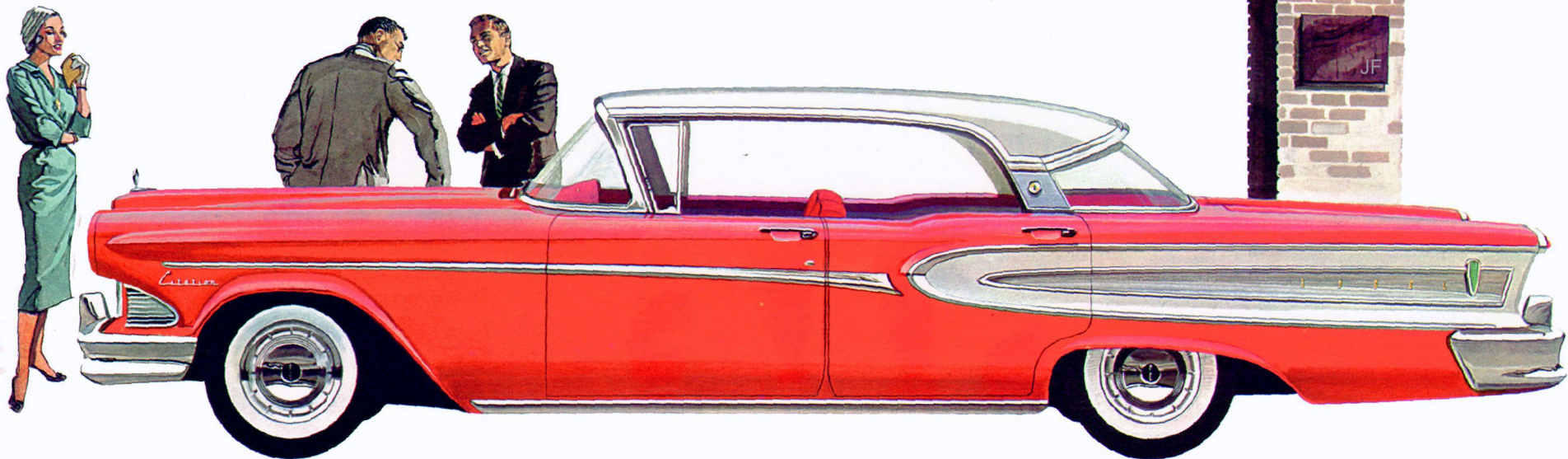

CORSAIR

RANGER

INTERIORS



The Edsel Citation 2-Door Hardtop

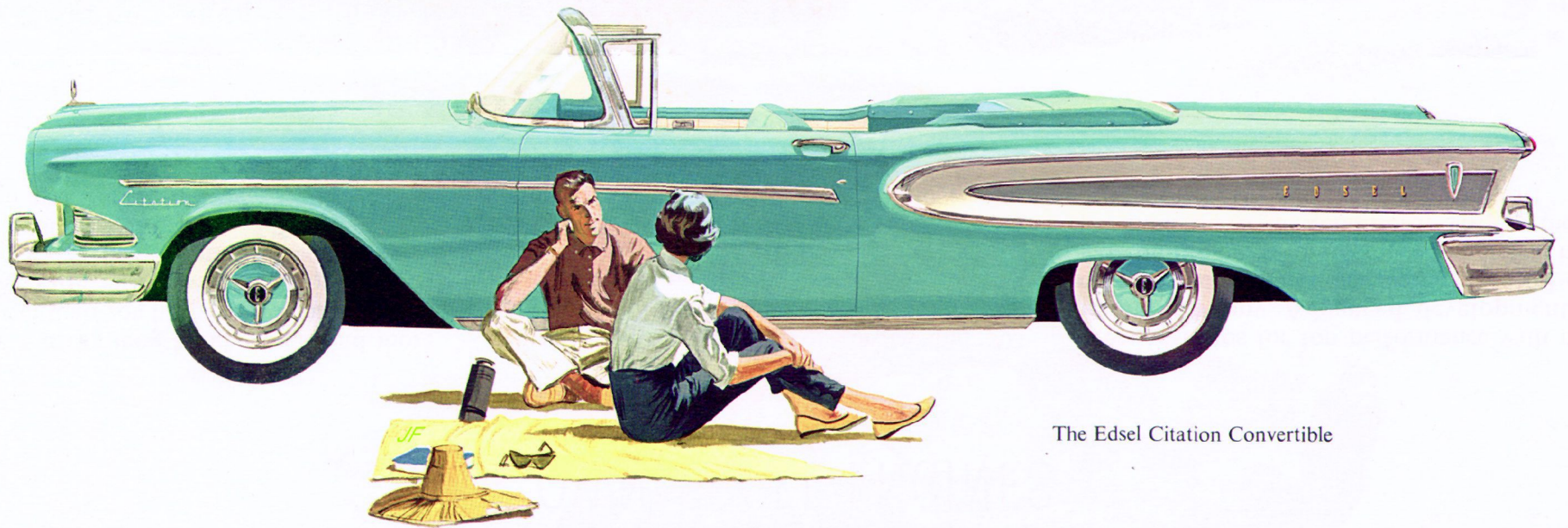

The Edsel Citation Convertible

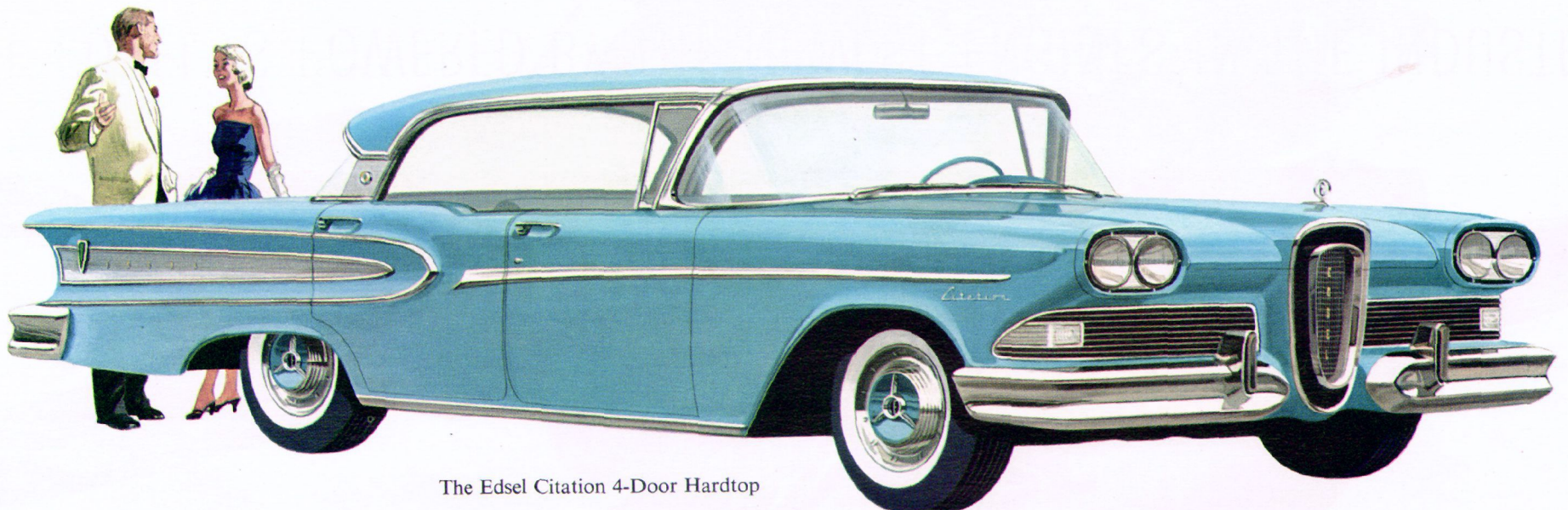

The Edsel Citation 4-Door Hardtop

CITATION

THE SAME AIR OF ELEGANCE, THE SAME LOOK OF SUPERB ABILITY, IN ALL ITS 18 MODELS

You can choose from any of the 18 Edsel models and be sure of styling that is clean, crisp and distinctive—from the bold vertical grille to the sweep of Edsel's wide, low flight deck. Any one of the Edsel's outstanding advances—the exclusive Edsel engines or Teletouch Drive—would make it one of America's most capable cars. And the sum-total of dozens of others makes it the most convenient, most comfortable car you have ever driven. The Edsel's list of available new features is long. Examples: self-adjusting brakes; contour seats; a dial that lets you select temperature, quantity and direction of air with an easy twist; a warning

light that flashes when oil is one quart low; a release that enables you to open the luggage compartment from the driver's seat; a miles-per-hour selector dial which you preset at the maximum speed you wish to travel—and when you exceed it, the speedometer glows red. With all these great advances you may well ask, how much does the Edsel cost? While the Edsel looks expensive, it actually isn't. Prices range from just above the lowest to just below the highest. In any one of its four series—Citation, Corsair, Pacer or Ranger—or among the station wagons—there's an Edsel just right for you.

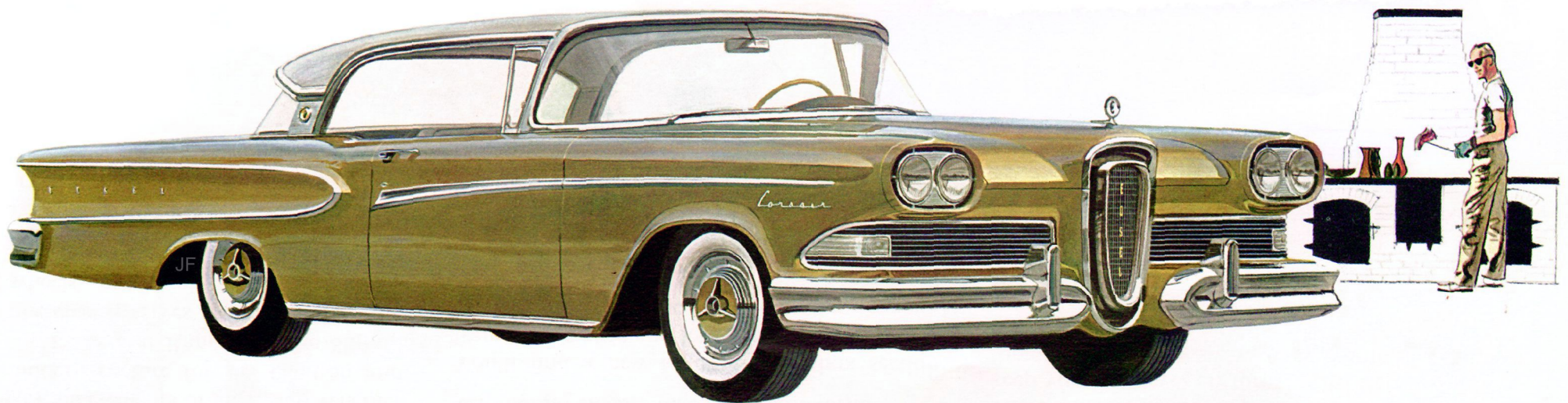

The Edsel Corsair 2-Door Hardtop

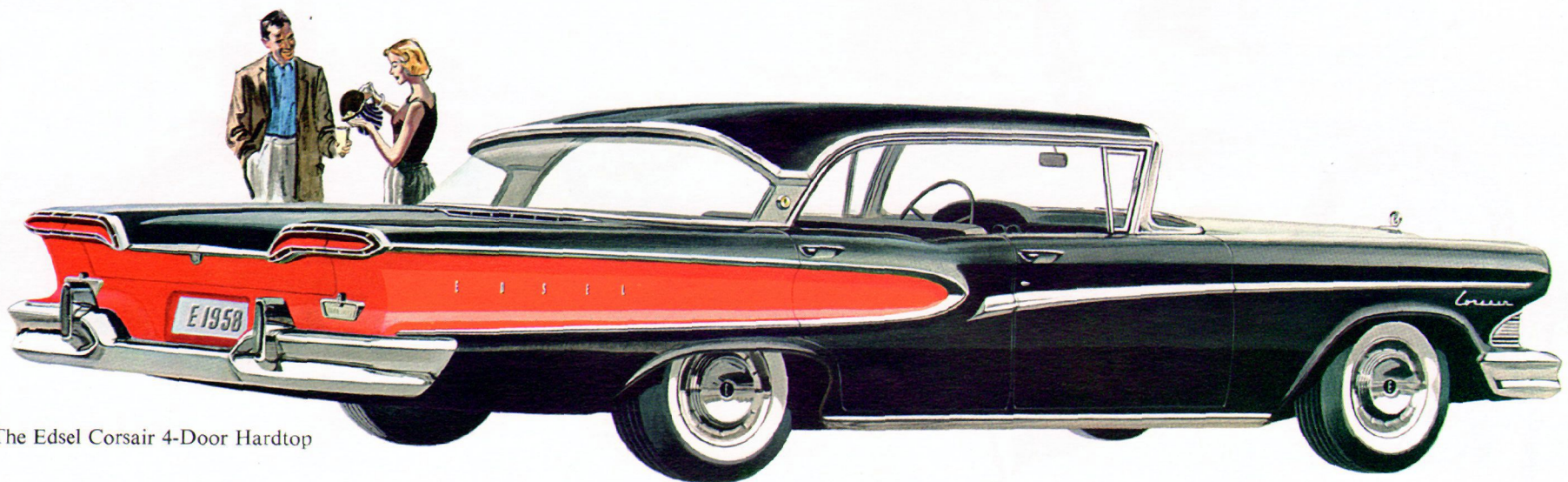

The Edsel Corsair 4-Door Hardtop

CORSAIR



The Edsel Pacer 4-Door Hardtop

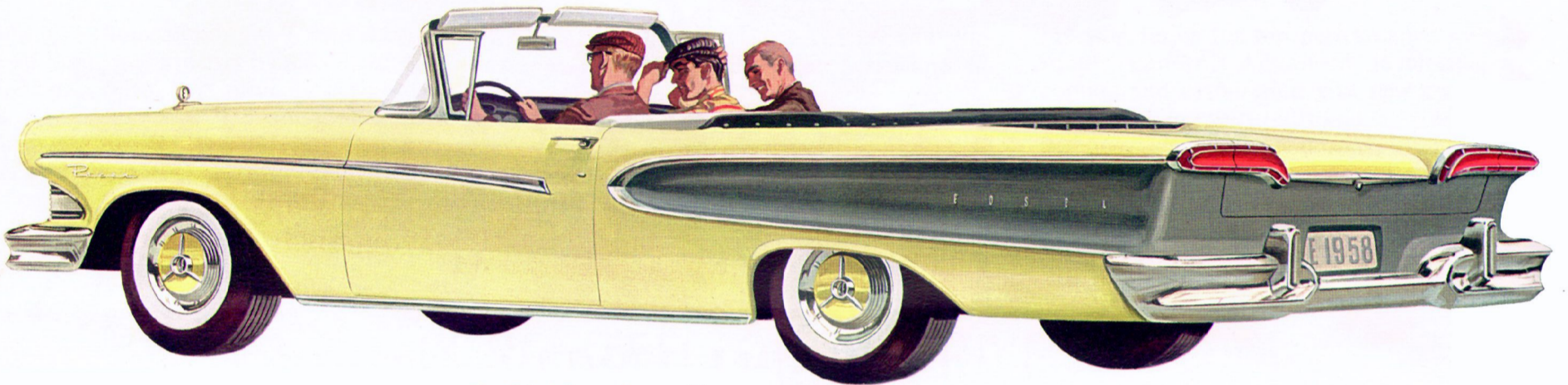

The Edsel Pacer Convertible

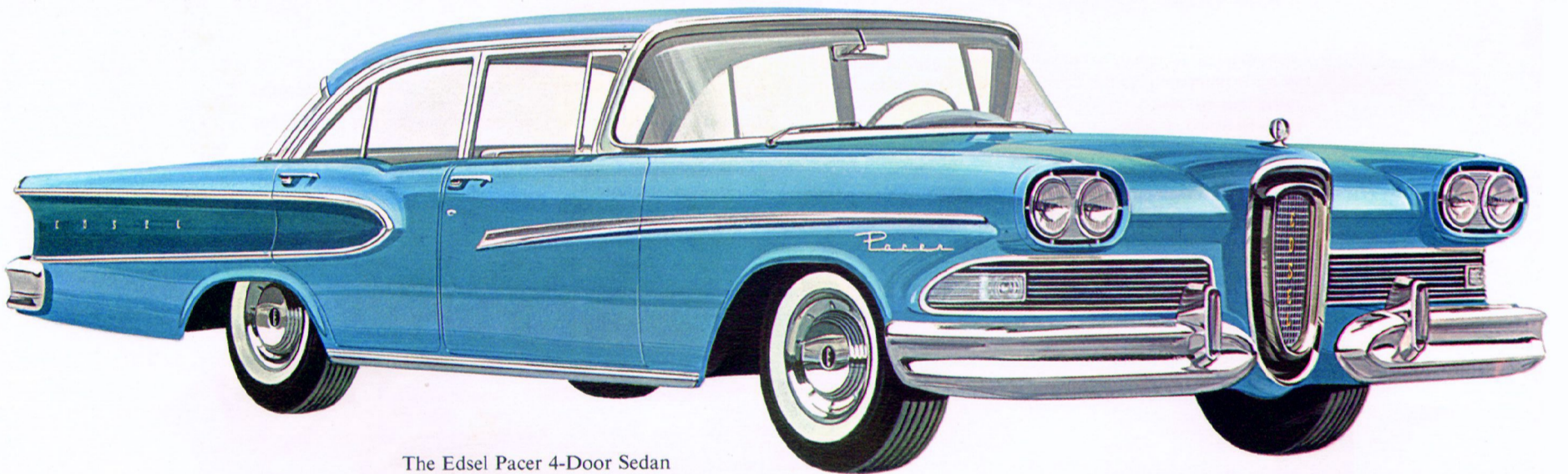

The Edsel Pacer 4-Door Sedan

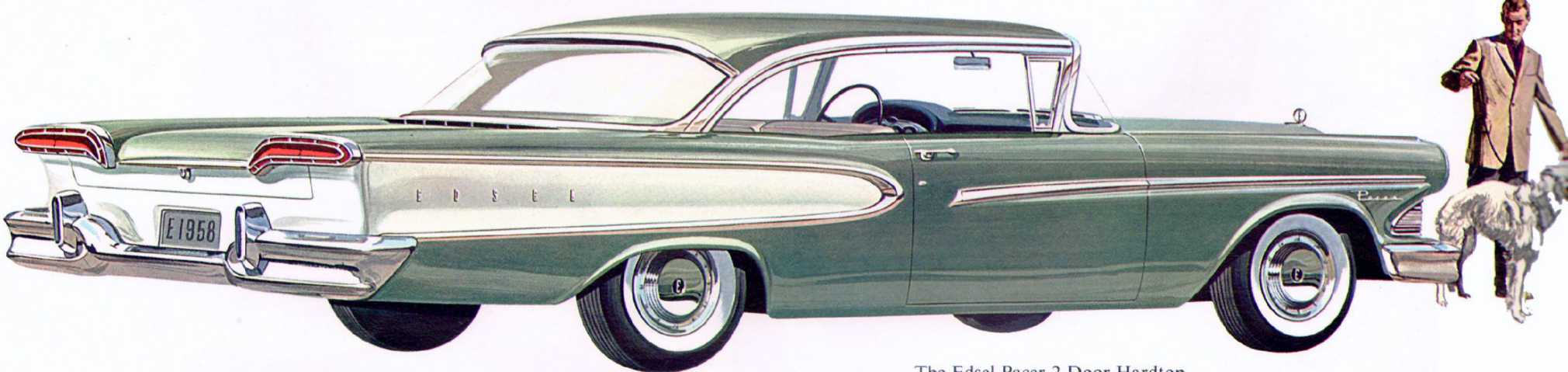

The Edsel Pacer 2-Door Hardtop

PACER

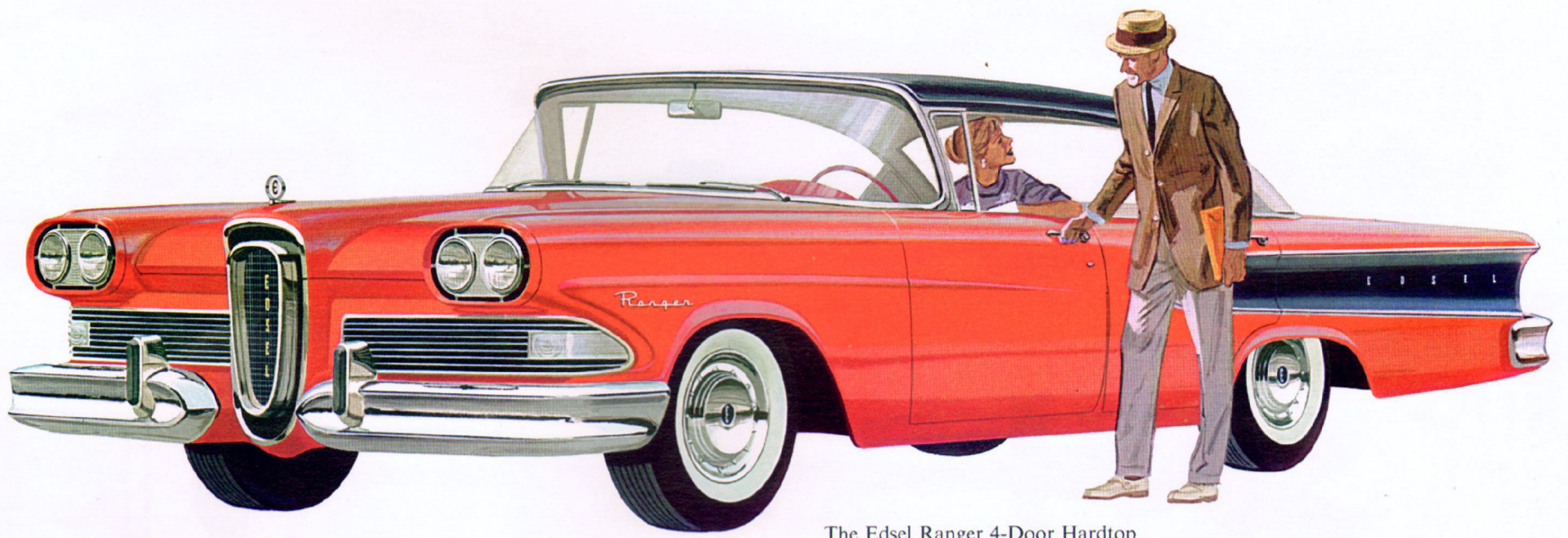

The Edsel Ranger 4-Door Hardtop

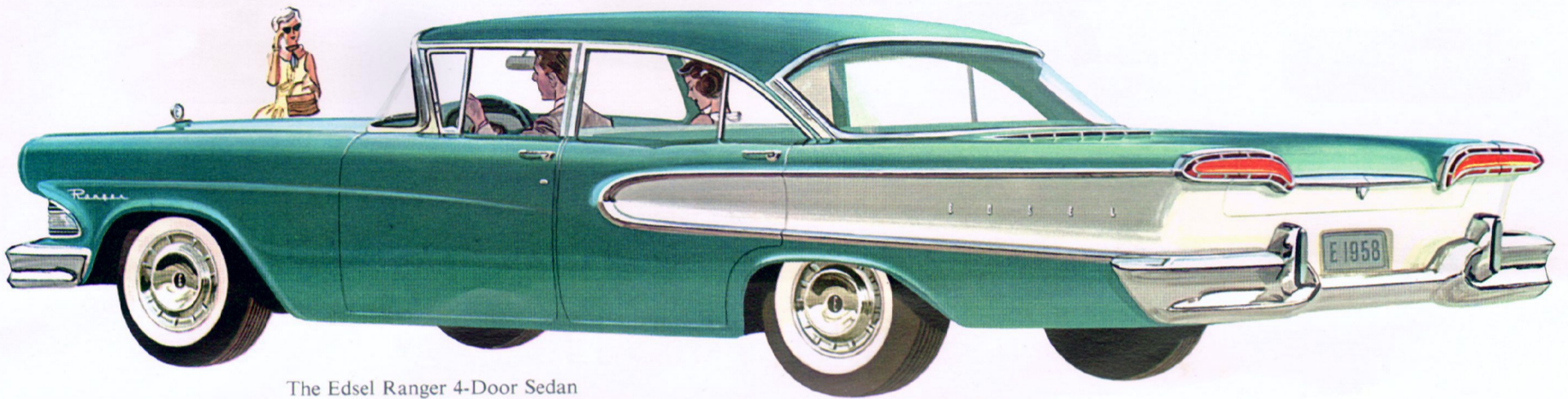

The Edsel Ranger 4-Door Sedan

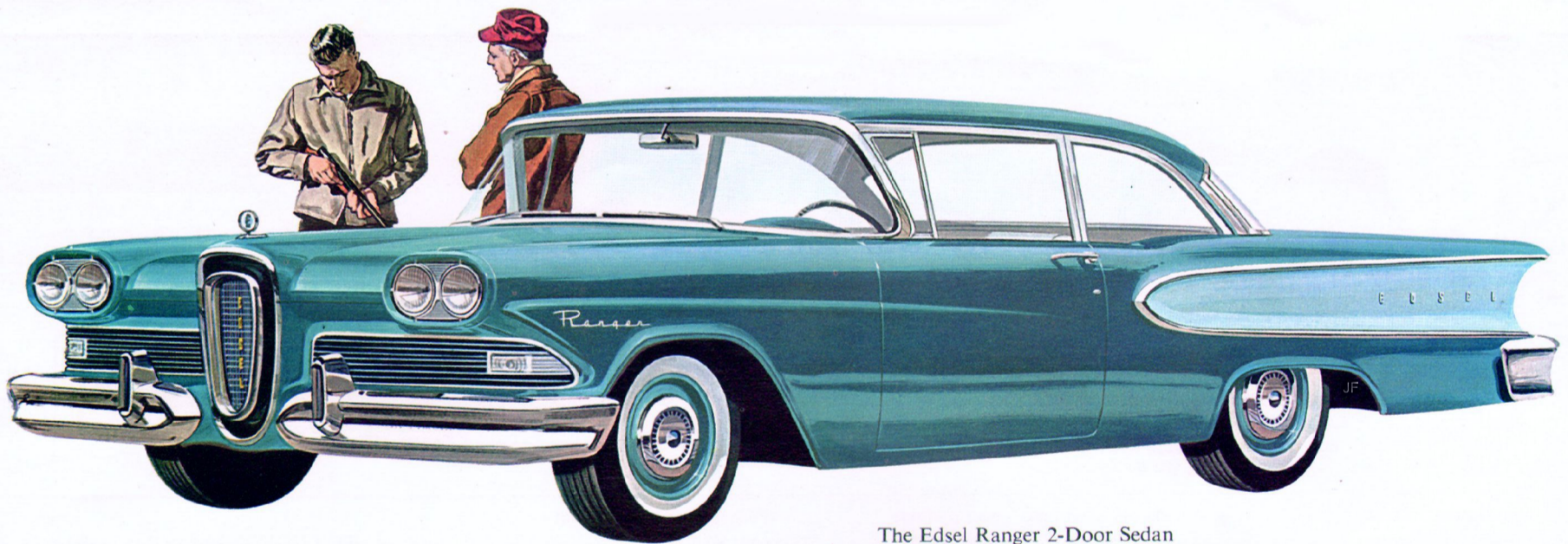

The Edsel Ranger 2-Door Sedan

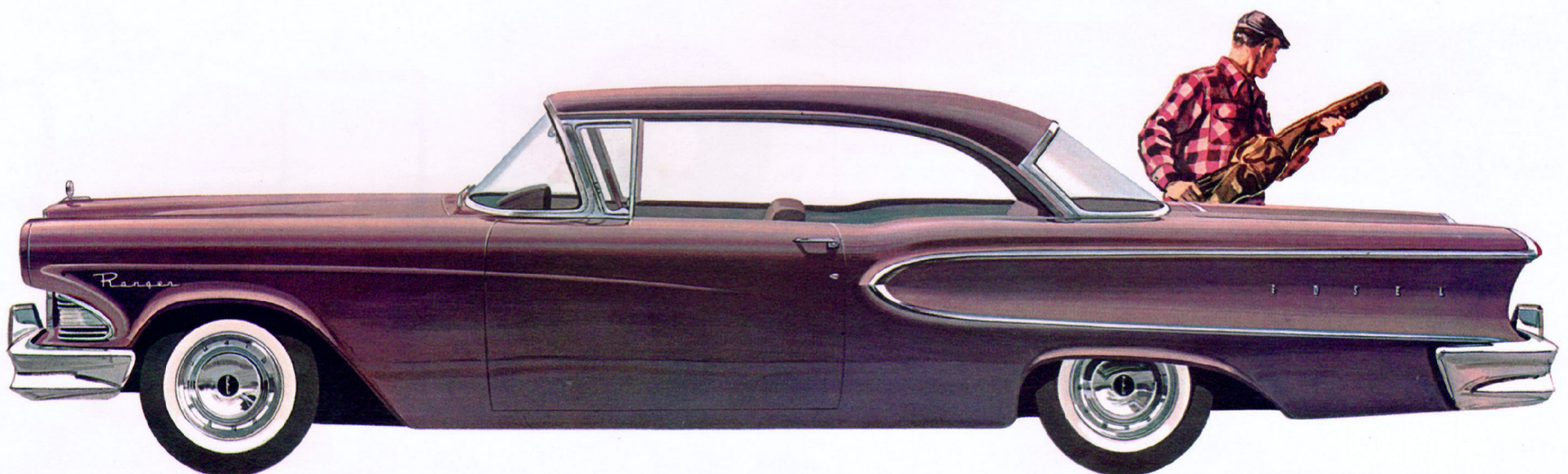

The Edsel Ranger 2-Door Hardtop

RANGER

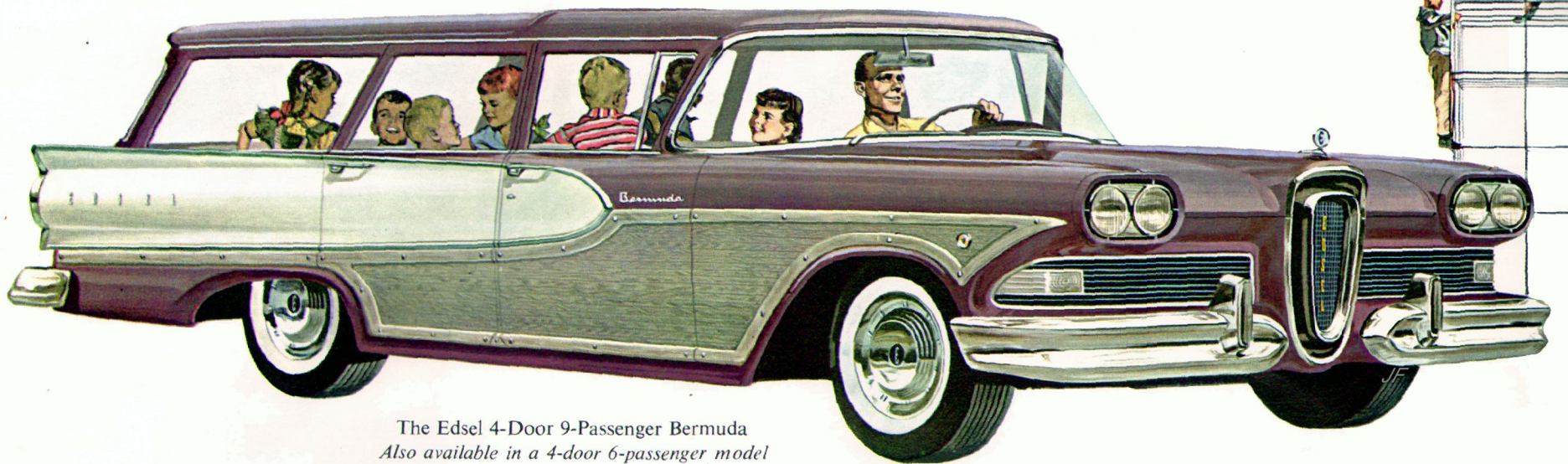

The Edsel 4-Door 9-Passenger Bermuda
Also available in a 4-door 6-passenger model

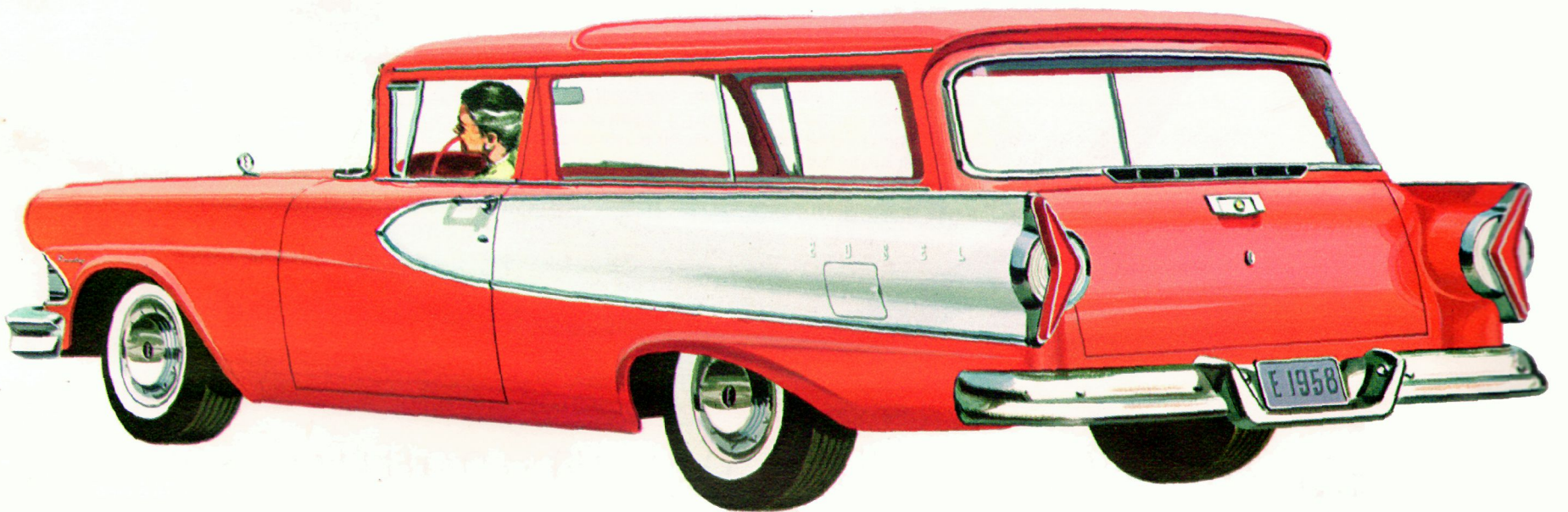

The Edsel 2-Door 6-Passenger Roundup

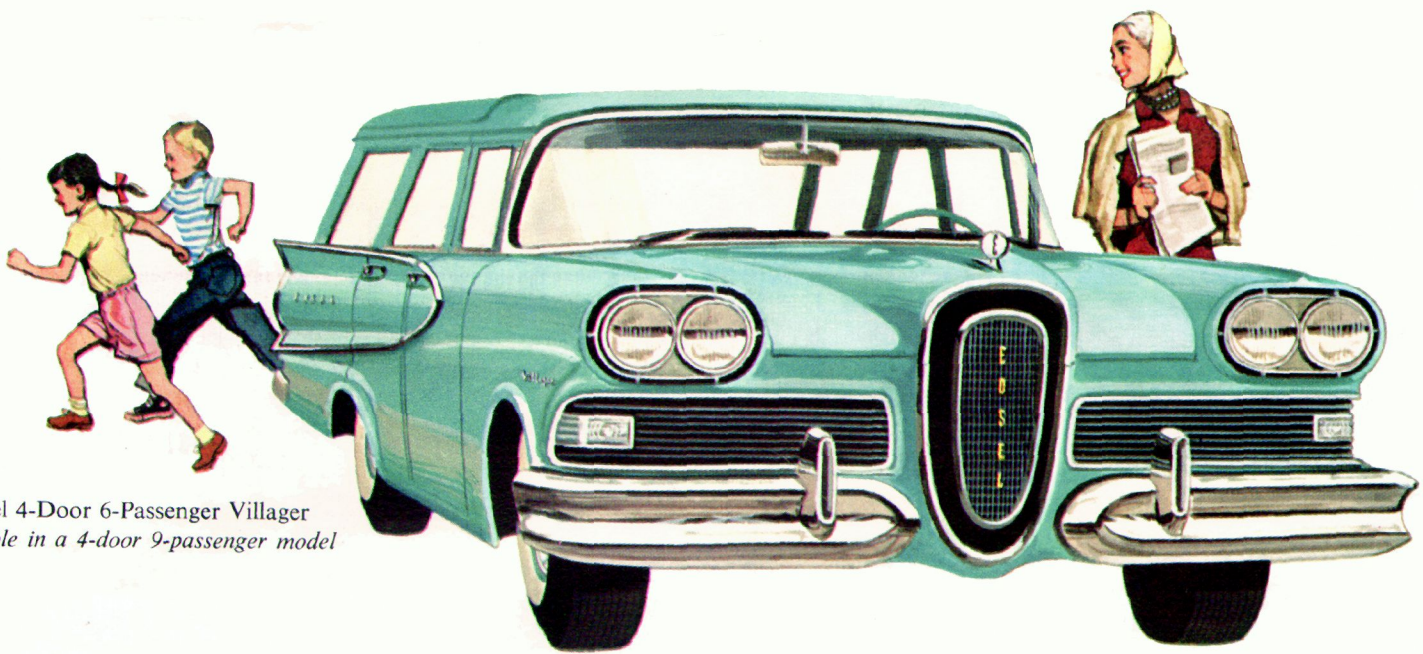

The Edsel 4-Door 6-Passenger Villager
Also available in a 4-door 9-passenger model

EVERYTHING THE EDSSEL DOES, IT DOES IN STYLE

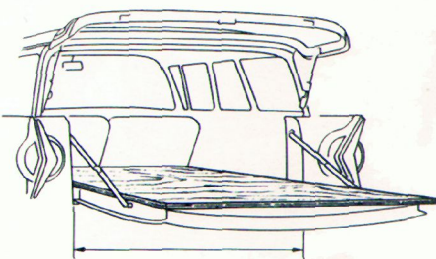

Extra-wide lift-gate area for wider loads, wider sight. Easy one-hand operation!

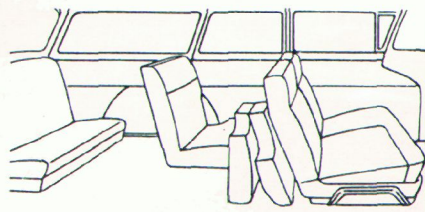

In 9-passenger, 4-door wagons, a portion of the second seat folds to let rear-seat passengers enter or leave easily.

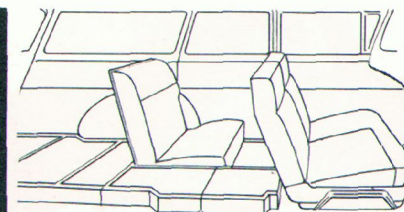

Cushions in the third seat may be easily removed and the support folded down to provide a wide, level floor for loads.

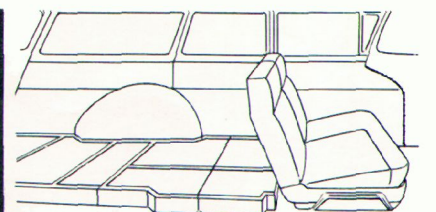

The second seat folds flat to provide still more load space—over 7 ft. 3 in.; more than 8 ft. 10 in. with tail gate open.

This is the age of the station wagon. It must match a hundred needs of as many different people—so it takes on many new faces, in five different models, as Edsel presents it. And a single glance proves that its elegance matches the high promise of full utility afforded by all Edsel station wagon models.

Most important, each one offers true station wagon convertibility—from luxurious passenger car to high-styled cargo carrier—in seconds. They feature space—in headroom, footroom, elbowroom and load-room. You'll find a new measure of riding comfort, stability and road poise, too—for Edsel wagons are

designed to hold the highway. Their load-design rear springs help adjust the load to the road. Ball joint front suspension, that handles both steering and up-and-down wheel movement, makes handling easier. For show, *and for go*, there's never been a station wagon like the Edsel.

STATION WAGONS

INSIDE AND OUT, EDESEL COLORS GO TOGETHER ELEGANTLY

In the sparkle, tone and textures of Edsel's colors and upholsteries you sense the new trends in automotive styling: brightness, individuality, and color harmony, outside and in.

In Edsel models of every series, you'll like the way that stylists have keyed each interior to contrast or blend harmoniously with the wide range of Edsel single, two-tone, or tri-tone colors.

For this new car, Edsel craftsmen have developed a special flare with upholsteries. Whatever interior-exterior scheme you select, your Edsel will speak wonderfully well of you.



In the foreground, the rich interior of the Edsel Citation; in the background, the Citation 2-door Hardtop itself, in Royal Blue Metallic and Powder Blue. The foam rubber cushioned seats feature light blue hand-crush vinyl contrasting with the texture of Random Square cloth in medium blue.



Ice Green and Snow White are the colors that set off the elegance of this Ranger 4-Door Hardtop. Inside, these colors are matched by Surf pattern nylon-faced fabric with white boxcalf vinyl trim. The cushion edge panels and ceiling headlining are also vinyl.

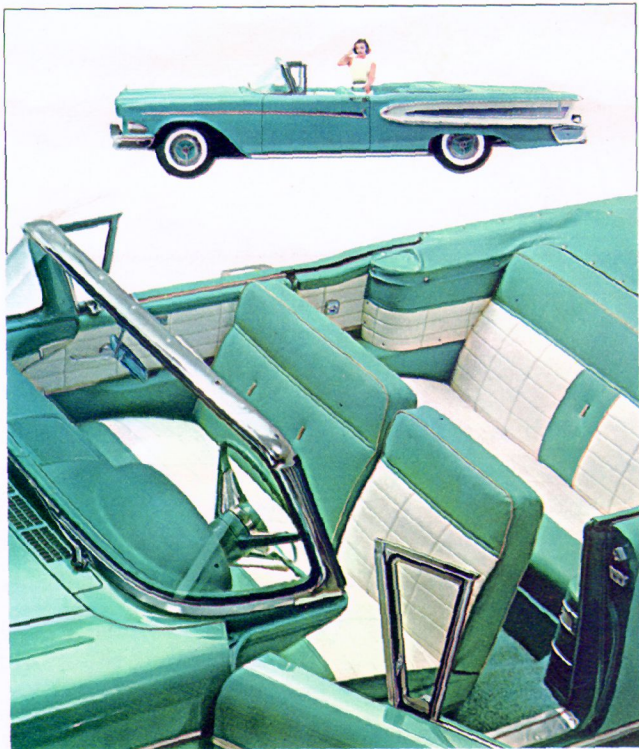

Turquoise and Frost White dramatically stress the long, low lines of the Citation Convertible with interior handsomely keyed to the same colors. The deep cushions feature a white box pattern insert.

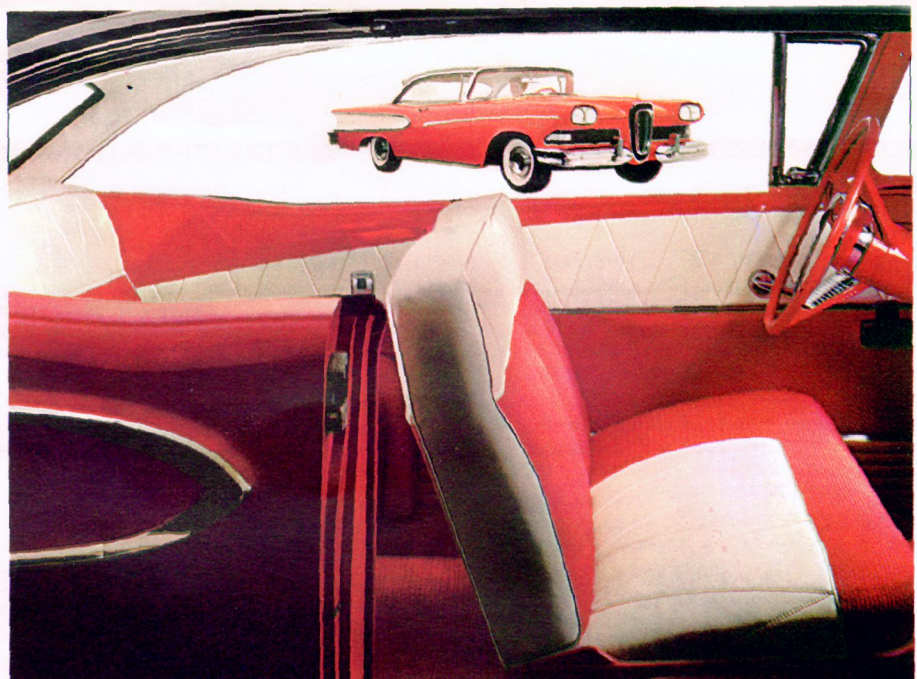

Ember Red with Snow White scallop keys the entire color range of this Pacer 2-Door Hardtop. Inside, the restful elegance of the contour front and rear foam rubber cushioned seats is set off by contrasting white boxcalf vinyl in triangular pattern and red Chain body cloth.



Edsel Jet Black and Ember Red set off the exterior beauty, and red and gray the tailored trim of this Corsair 4-Door Hardtop. The Mesh pattern seat fabric features narrow pleating set off by inserts and bolsters of metallic gray hand-crush vinyl.



Bermuda's exterior is Driftwood with chrome accents and Charcoal Brown Metallic finish with Snow White scallop. Interior features Driftwood boxcalf vinyl with brown Andes pattern saran.

EDSEL TELETOUCH DRIVE

YOU CAN SHIFT WITHOUT LIFTING A HAND FROM THE WHEEL

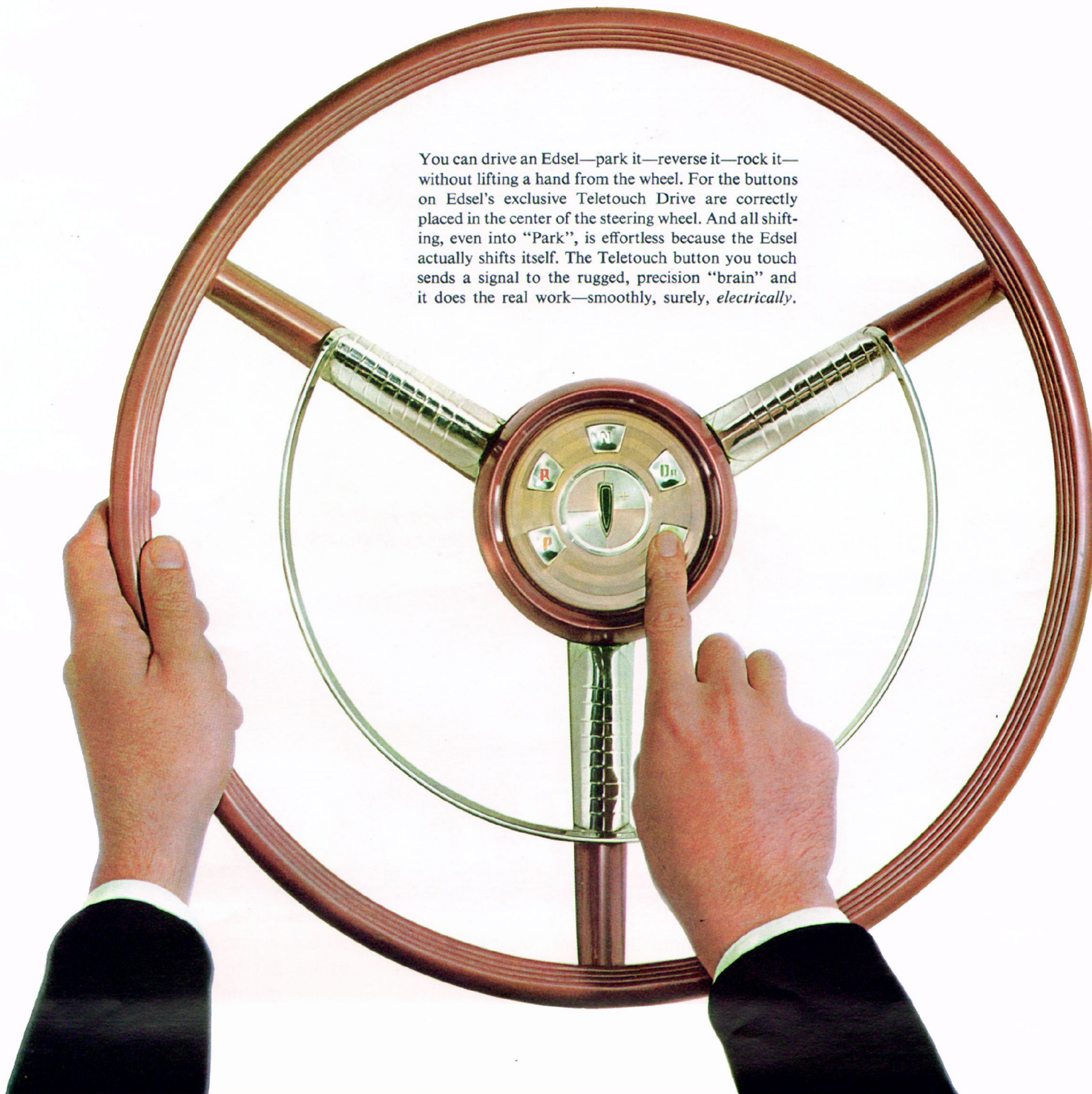

You can drive an Edsel—park it—reverse it—rock it—without lifting a hand from the wheel. For the buttons on Edsel's exclusive Teletouch Drive are correctly placed in the center of the steering wheel. And all shifting, even into "Park", is effortless because the Edsel actually shifts itself. The Teletouch button you touch sends a signal to the rugged, precision "brain" and it does the real work—smoothly, surely, *electrically*.

More than any other car, you can drive the Edsel by touch

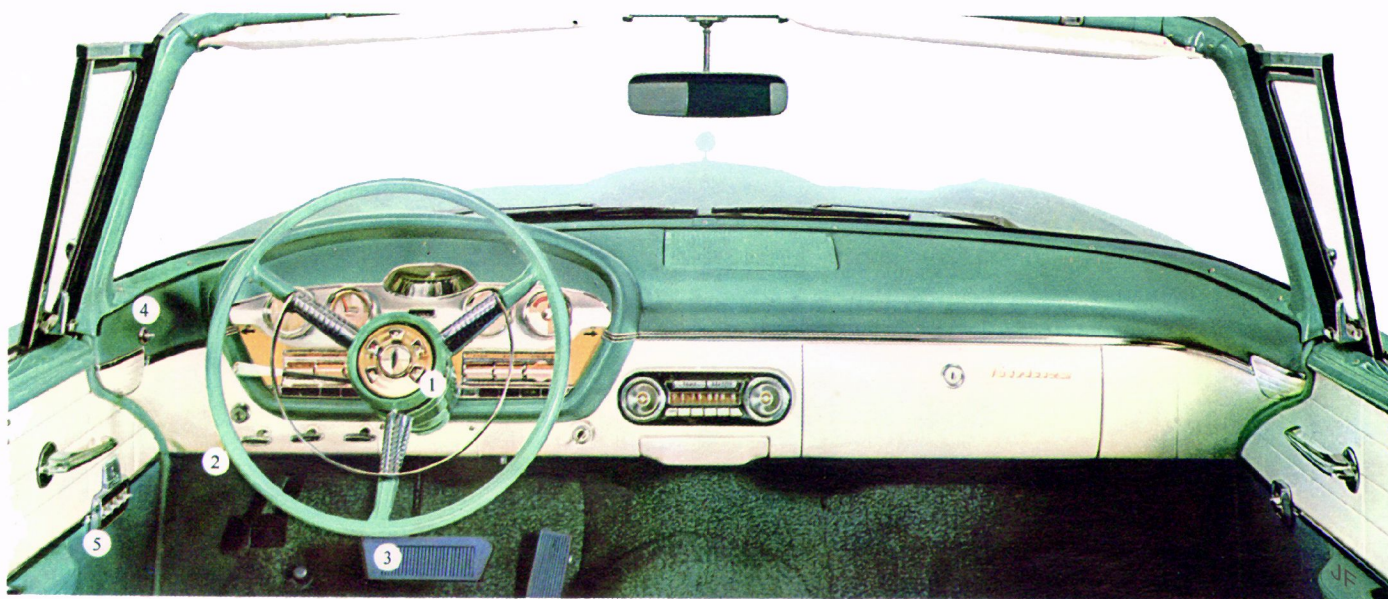

1. **TELETOUCH DRIVE**—Pushing a Teletouch button is easier than pressing a light switch. An electric motor selects the range and engages the transmission:
2. **POWER STEERING**—You maneuver and park with practically a feather-light touch—with optional Edsel Power Steering. Yet, as a safety factor, you still have the feel of the road.
3. **POWER BRAKES**—You ease to a stop—surely, safely—at the touch of a toe. For manifold vacuum does most

of the pedal-pushing for you. Available on all Edsel models.

4. **POWER SEAT**—Simply flick the 4-way switch and the optional Edsel Power Seat moves in the direction of the switch—up or down, forward or back.
5. **POWER WINDOWS**—For safety as well as convenience, a four-control master panel on the door next to the driver operates all side windows in the Edsel. Individual controls are also located below each window. Available on all models.

EDSEL FEATURES

NEVER BEFORE SO MUCH THAT'S NEW

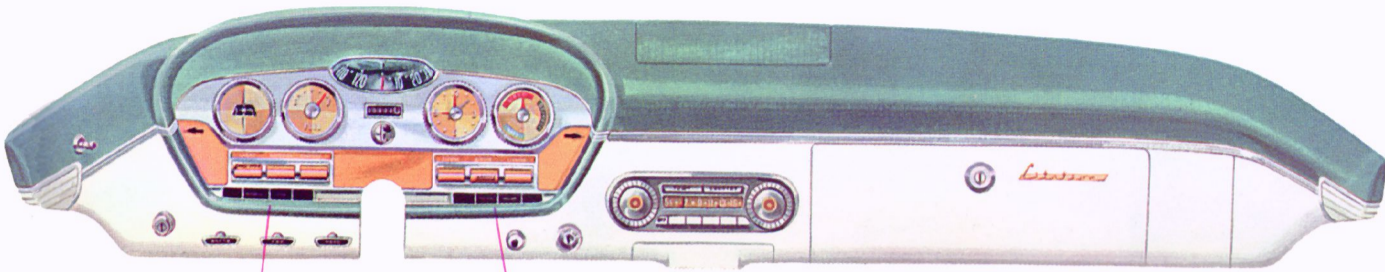

CONTROL CENTER INSTRUMENT PANEL—Following aircraft practice, the Edsel instrument panel places instruments, control

switches, and warning lights in three parallel horizontal rows with every unit clearly visible—right within finger-tip reach.



DIAL-TEMP SYSTEM*—One dial tunes in both heating and ventilation and also accommodates optional air conditioning. Automatic controls make all the adjustments.

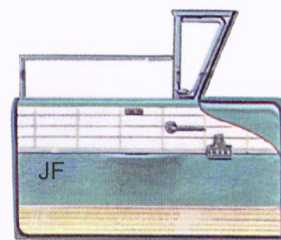

NEW INSIDE LOCKS—Edsel models feature two types of inside door locks, both of which are mounted for easy reach. Citation and Corsair series are equipped with sliding lock. Other models use button type.

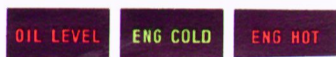

VISUAL WARNING LIGHTS (Left to right above)—Indicator lights report oil pressure, generator charging, parking brake "on"*, fuel tank near empty*, oil supply one quart low*, "engine cold", "engine hot".



ENGINE TACHOMETER*—This handsome panel-mounted precision instrument reports engine operation speed, provides ready check of performance. *Standard on Citation.*



SPEED WARNING LIGHT SPEEDOMETER*—You simply set the rotating warning dial to the safe cruising speed of your choice and when you exceed it, speedometer dial lights up in red.



PANEL-MOUNTED COMPASS*—With this accessory you know directions wherever you are. It's designed to fit right into the complete Edsel instrument panel beautifully.

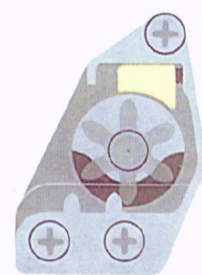

SAFETY LATCHES—Door and frame are latched together to resist accidental opening in case of impact.



NEW ROOMINESS AND COMFORT—Built-in footrests are stamped deeply into the Edsel rear compartment floor to add legroom and headroom and increase passenger comfort.

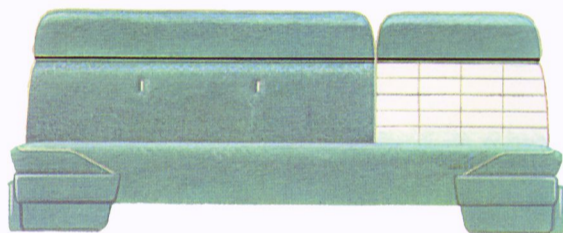

CONTROL-CENTER SPLIT SEAT—Emphasizes the care designers and stylists have taken to provide both driver ease and passenger comfort; makes entrance to the rear seat in two-door bodies easier.

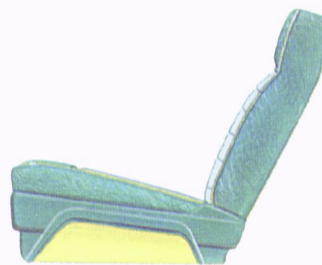

CONTOUR FRONT SEAT—The top portion of the seat back in Citation, Corsair, Pacer and Bermuda models is canted forward to give luxurious shoulder support to driver and passengers.



SAFETY STEERING WHEEL—Inverted, deep-down center is designed to distribute stress under impact, provide safety protection.



MARK OF ELEGANCE—Edsel's mobile elegance is highlighted by the bold vertical accent of its grille. Dual headlights emphasize long and sweeping hood line.



DISTINCTIVE AND DRAMATIC—Edsel's hood emblem is the letter "E", elegantly inscribed in the inner disc.

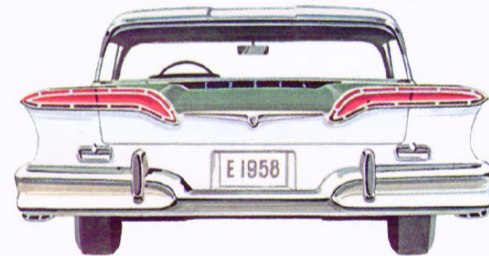

WIDE AND SWEEPING—Edsel's low, wide flight deck is a masterful example of sculpture in metal, contrast in color. Note unique taillight assemblies.

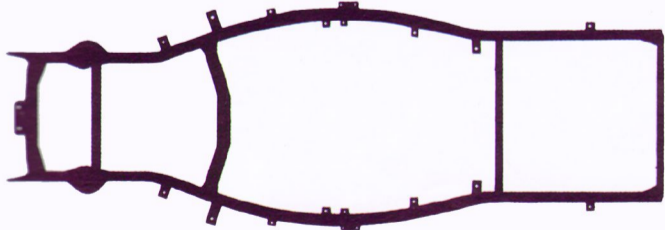

GUARD RAIL FRAME—Flared frame side rail members provide a protective base around the body for safety, permit a depressed floor for extra inside "height". A firm foundation for Edsel's poise.

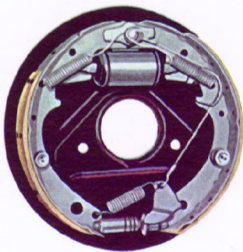

SELF-ADJUSTING BRAKES—Every time you put an Edsel into reverse and touch the brake, they adjust—automatically.

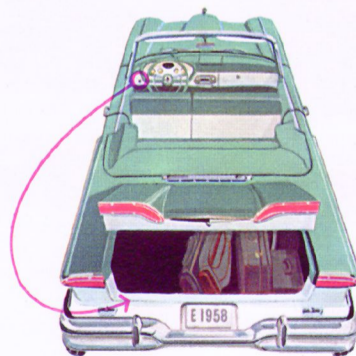

AUTOMATIC REAR DECK OPENER*—Dash-mounted key-lock lets you open luggage compartment—right from the driver's seat.

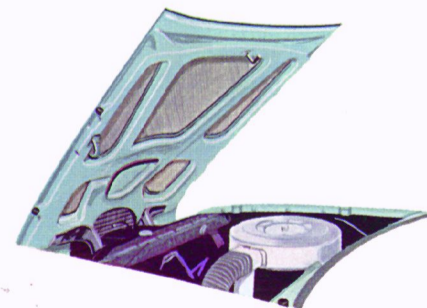

INSIDE LOCKING HOOD—The hood of the Edsel is released from the driver's seat as an added protection against tampering with engine, battery and underhood accessories.

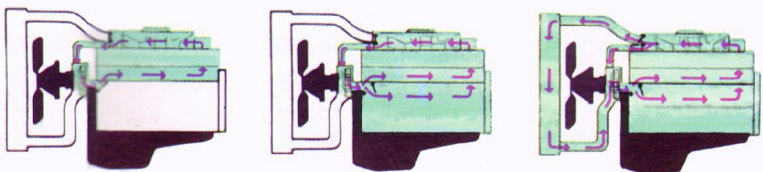

THREE-STAGE COOLING SYSTEM—Citation and Corsair models have a special three-stage cooling system to provide fast, even warm-up for peak cold-weather performance. Gives maximum fuel economy and extends engine life.

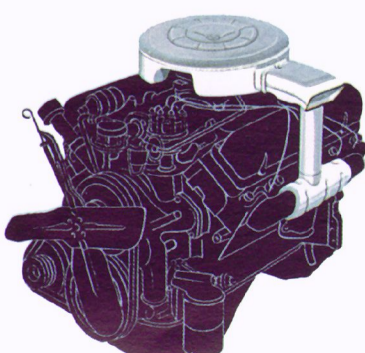

TEMPERED AIR INDUCTION SYSTEM—On Citation and Corsair, fuel-air mixture is exhaust-heated for quicker warm-up in cold weather.

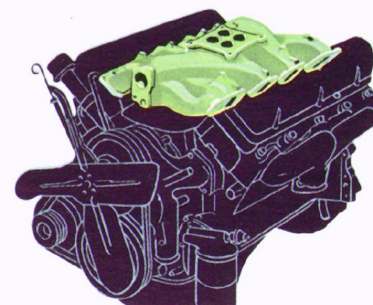

WATER-WARMED INTAKE MANIFOLD—For faster peak performance after starting, Citation and Corsair engines feature a water jacket in the intake manifold that stabilizes fuel-air mixture for maximum performance and economy.

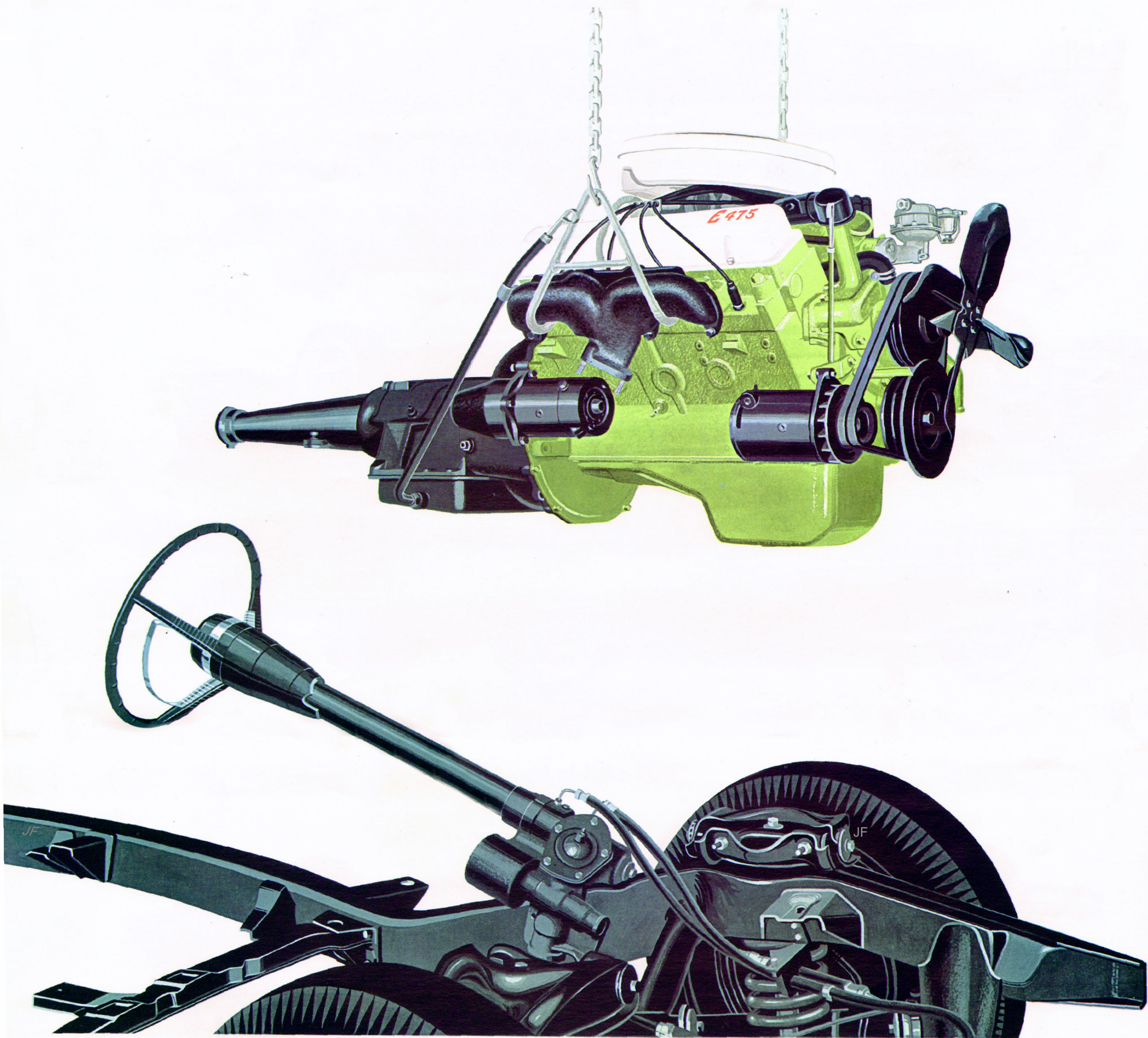

THE EDSSEL IS POWERED BY THE NEWEST ENGINES IN THE INDUSTRY

ITS OWN' EDSSEL ENGINES

Under the Edsel's long hood, you'll find more usable power than you have ever handled before. That's why Edsel offers two specially designed V-8s. The E-475 delivering 475 pound-feet of torque (thrusting power) and 345 horsepower in Citation and Corsair models. And the E-400

delivering 400 pound-feet of torque and 303 horsepower in Pacer and Ranger Series and all Station Wagon models.

Each of these engines features wedge-shaped combustion chambers with peak 10.5 to 1 com-

pression ratios for top performance with maximum economy. Advanced developments in cooling and carburetion give new control over gas-consuming warm-ups and economical miles per hour under all conditions. They're the industry's newest—and the industry's best!

EDSEL CHASSIS

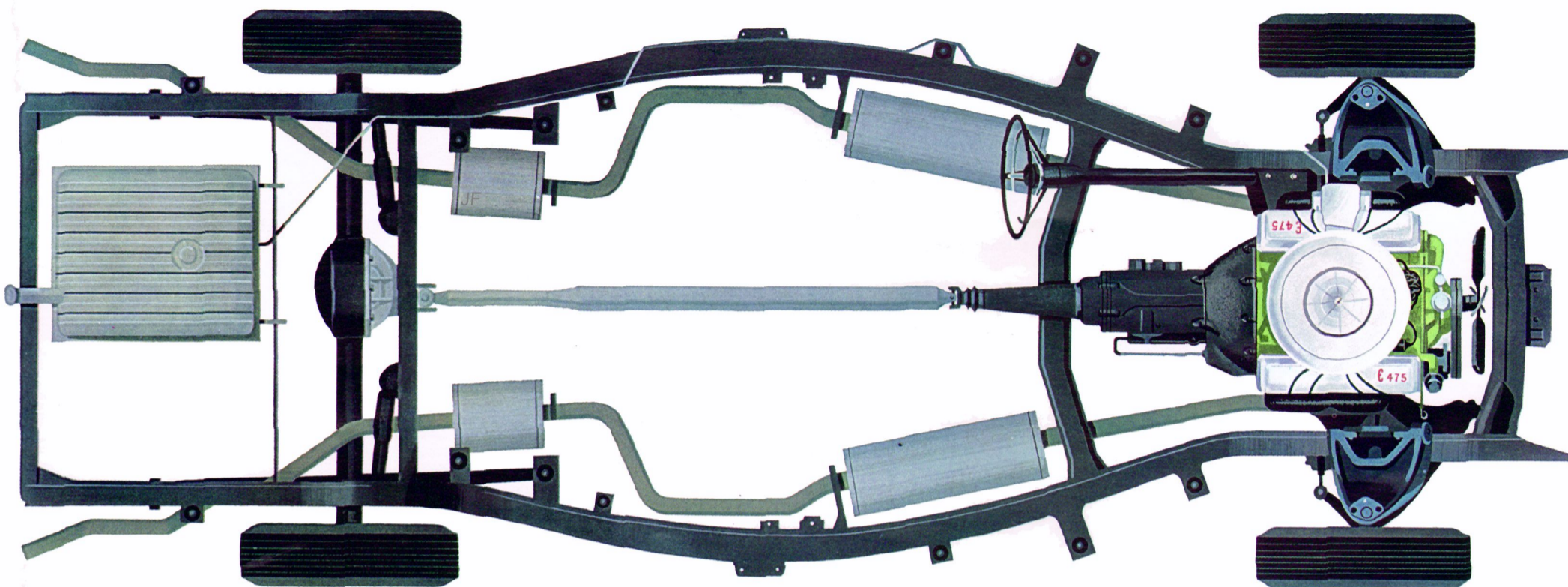

THIS IS THE FOUNDATION OF EDSEL PERFORMANCE

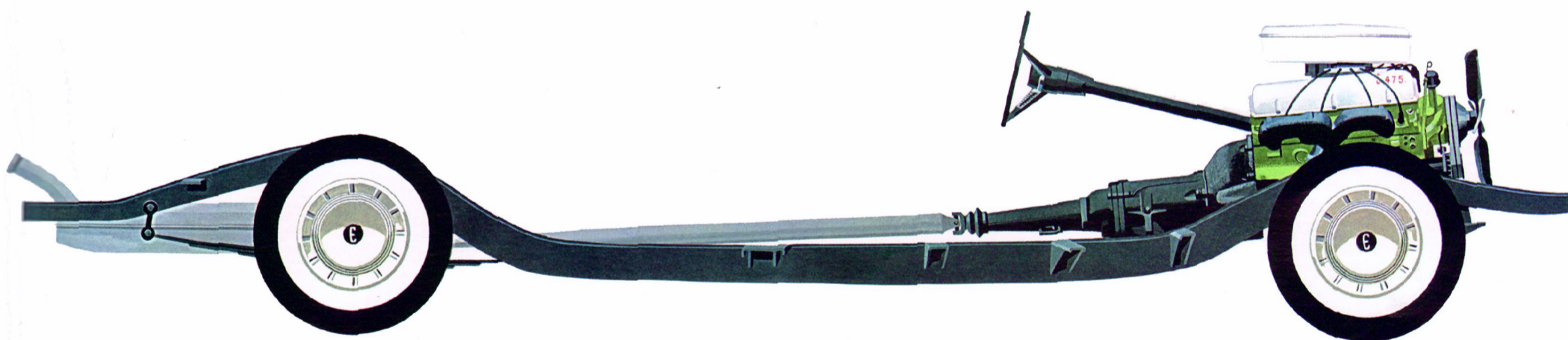

The chassis is the least seen, yet one of the hardest working elements of an Edsel. Whether it is the under-structure for the Citation and Corsair, the Pacer and Ranger, or the Station Wagons, the chassis serves as a bridge between the four wheels—carries all the load.

The chassis is literally the foundation upon which almost all of the Edsel's capabilities are built—its ride, its handling, its performance, its

safety and ruggedness. In an Edsel, the modern automobile chassis takes its finest form.

You'll find a new kind of basic box section frame that's wide and low, yet torsion-resistant; extra strong to keep the Edsel body soundly rigid.

You get swept-back, angle-poised ball joint front suspension that provides a trailing arm type of suspension to help front wheels smooth out road irregularities. Spring rates are balanced

to rear suspension for even flow over bumps. There's a torsion bar type stabilizer that helps keep your car level on turns, provides resisting force which checks sway. A new bottom orbit hypoid gear design permits a lower drive shaft tunnel in the rear compartment to give you more legroom.

These and many other features all add up to an easier handling, more luxurious riding, better balanced car for the American road—the new Edsel.

ENGINE SPECIFICATIONS

TYPE: 90° V-8 low-friction type engine with deep crankcase section. Overhead intake and exhaust valves.

RATING AND DIMENSIONS: E-475 V-8 Corsair, Citation, 410 cu. in.; h.p., 345; torque, 475; compression ratio, 10.5-1; bore, 4.20 inches; stroke, 3.70 inches. E-400 V-8 Ranger, Pacer, Station Wagon, 361 cu. in.; h.p., 303; torque, 400; compression ratio, 10.5-1; bore, 4.05 inches; stroke, 3.50 inches.

FUEL SYSTEM: Four-barrel carburetor standard both engines. E-475 V-8 equipped with carburetor air induction system. 20-gallon fuel tank. Fuel filter in both tank and fuel pump.

ELECTRICAL SYSTEM: 12-volt. 35-amp. generator (30-amp. on E-400 V-8 engine). Battery, 78-plate.

IGNITION SYSTEM: Single breaker point distributor with combination centrifugal-vacuum spark advance control. 18-mm anti-fouling spark plugs.

VALVE TRAIN: Free-turning overhead valves with integral valve guides. Silent chain-driven camshaft on both engines.

LUBRICATION SYSTEM: Controlled full-pressure lubrication. Full-flow replaceable-element type oil filter. Rotor-type oil pump. Directed-flow crankcase ventilation. Oil capacity both engines: 6 quarts with filter change; 5 quarts without.

COOLING SYSTEM: E-475 V-8: three-stage with water-jacketed intake manifold. E-400 V-8: two-stage system. Both engines: full-length water jacket, centrifugal type water pump, positive action thermostats. Cooling system capacity without heater: E-475 V-8, 2.2 quarts; E-400 V-8, 18.5 quarts.

EXHAUST SYSTEM: Free-flow manifolds. Dual exhaust standard on Citation convertible, optional at extra cost on all other models.

TRANSMISSION AND

REAR AXLE SPECIFICATIONS

AUTOMATIC TRANSMISSION: Torque converter and 3-speed planetary gear train. Available with Teletouch Drive control buttons on all models. Also available with conventional selector lever on Pacer, Ranger and Station Wagon.

CONVENTIONAL TRANSMISSION: Selective gear type with three forward speeds.

OVERDRIVE TRANSMISSION: Planetary gear train providing 4th forward speed attached to conventional 3-speed transmission. Engine speed reduction, approximately 28%.

CLUTCH: (With conventional or Overdrive transmission) Semi-centrifugal, single dry plate. Diameter of clutch face, 11.0 inches.

REAR AXLE: Semi-floating. Hypoid gears. Straddle-mounted pinion, tapered roller bearings.

The specifications contained herein were in effect at the time this catalog was approved for printing. Edsel Division of Ford Motor Company reserves right to discontinue models at any time, or change specifications or design, without notice and without incurring obligation. Some of the items illustrated or referred to are optional at extra cost. For the price of the Edsel model with the equipment you desire, see your Edsel dealer.

CHASSIS SPECIFICATIONS

FRAME: Rigid ladder-type, flared design. Welded box-section reinforced side rails with five cross-members. Additional X-bracing for convertible.

FRONT SUSPENSION: Independent ball-joint suspension with swept-back design. Rubber bushings for front suspension lower arm pivot points. Coil springs. Direct-acting hydraulic shock absorbers mounted with rubber insulators. Rubber-mounted torsion type stabilizer bar.

REAR SUSPENSION: Hotchkiss Drive with longitudinally mounted, semi-elliptic, 55-inch leaf type springs. Direct-acting, sea-leg mounted, hydraulic shock absorbers.

STEERING: Recirculating ball and nut type gear. Equal-length tie rods.

BRAKES: Hydraulic, internal expanding type. Self-adjusting. Total brake lining area: Citation and Corsair, 212.8 square inches; Pacer, Ranger and Station Wagon, 191.5 square inches.

PARKING BRAKE: Independent mechanical, operating on the rear wheels. Pedal-operated with release handle on instrument panel.

WHEELS AND TIRES: 14-inch disc wheels. Tubeless tires; on Citation and Corsair, 8.50 x 14, 4-ply; on Pacer, Ranger and Station Wagon, 8.00 x 14, 4-ply. White sidewall tires optional at extra cost on all models.

DIMENSIONS

CITATION AND CORSAIR: Wheelbase, 124.05 inches. Over-all length (including bumper guards), 218.86 inches. Over-all width, 79.84 inches. Over-all height (4-door hardtop, loaded), 56.83 inches. Tread: (F) 59.38 inches; (R) 59.0 inches.

PACER AND RANGER: Wheelbase, 118.04 inches. Over-all length (including bumper guards), 213.17 inches. Over-all width, 78.82 inches. Over-all height (4-door hardtop, loaded), 56.42 inches. Tread: (F) 59.44 inches; (R) 59.0 inches.

STATION WAGONS: Wheelbase, 116.02 inches. Over-all length (including bumper guards), 205.47 inches. Over-all width, 77.14 inches. Over-all height (loaded), 58.87 inches. Tread: (F) 58.97 inches; (R) 56.40 inches.

OPTIONAL EQUIPMENT (at extra cost)

Automatic transmission with Teletouch Drive. Automatic transmission with conventional selector lever. Overdrive transmission. Nine-tube, Station-Seeking radio. Eight-tube radio. Heater, defroster and ventilation system with Dial-temp control. Air conditioner and heater system with Dial-temp control. Power steering. Power brakes. Power-operated windows. Four-way power seat. Safety-plus package. Tachometer. Compass. Touch lubrication. Parking brake warning light. Fuel level warning light. Oil level warning light.



CROSS-COUNTRY GREEN LIGHT SERVICE—One of the advantages of Edsel ownership is the nationwide network of Edsel dealerships. Edsel Dealers' Green Light Service means "More Go for Your Money".