

SERIES F-1

Max. Gross Vehicle Weight: 4,700 lbs.

Nominal Tonnage Rating: Half-Ton

6½ FT. PICKUP

MASTER OF A THOUSAND-AND-ONE LIGHT DELIVERY JOBS

LONG WEARING ALL-STEEL FLOOR has hardwood subfloor to minimize denting. Skid strips stamped in, can't work loose.

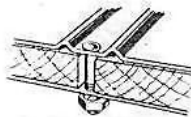

NEW HYPOID AXLE, semi-floating type. Husky pinion. Quiet running. New, exclusive, integral housing fully exposes differential for easy maintenance. Shafts removable from wheel end.

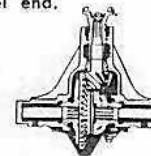

NO-CATCH ROLLED-EDGE FLARE-BOARDS strengthen body, offer better sliding surface for objects loaded from side. Stake pockets permit mounting of up-rights for special sides and tops.

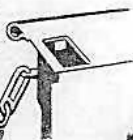

NEW MILLION DOLLAR CAB features new 3-way air control. New coach-type seat for comfort. New, Level Action cab mounting to frame for longer cab life. New Spiralounge floating seat with variable-rate spiral coil spring and hydraulic shock absorber available for comfort-plus.

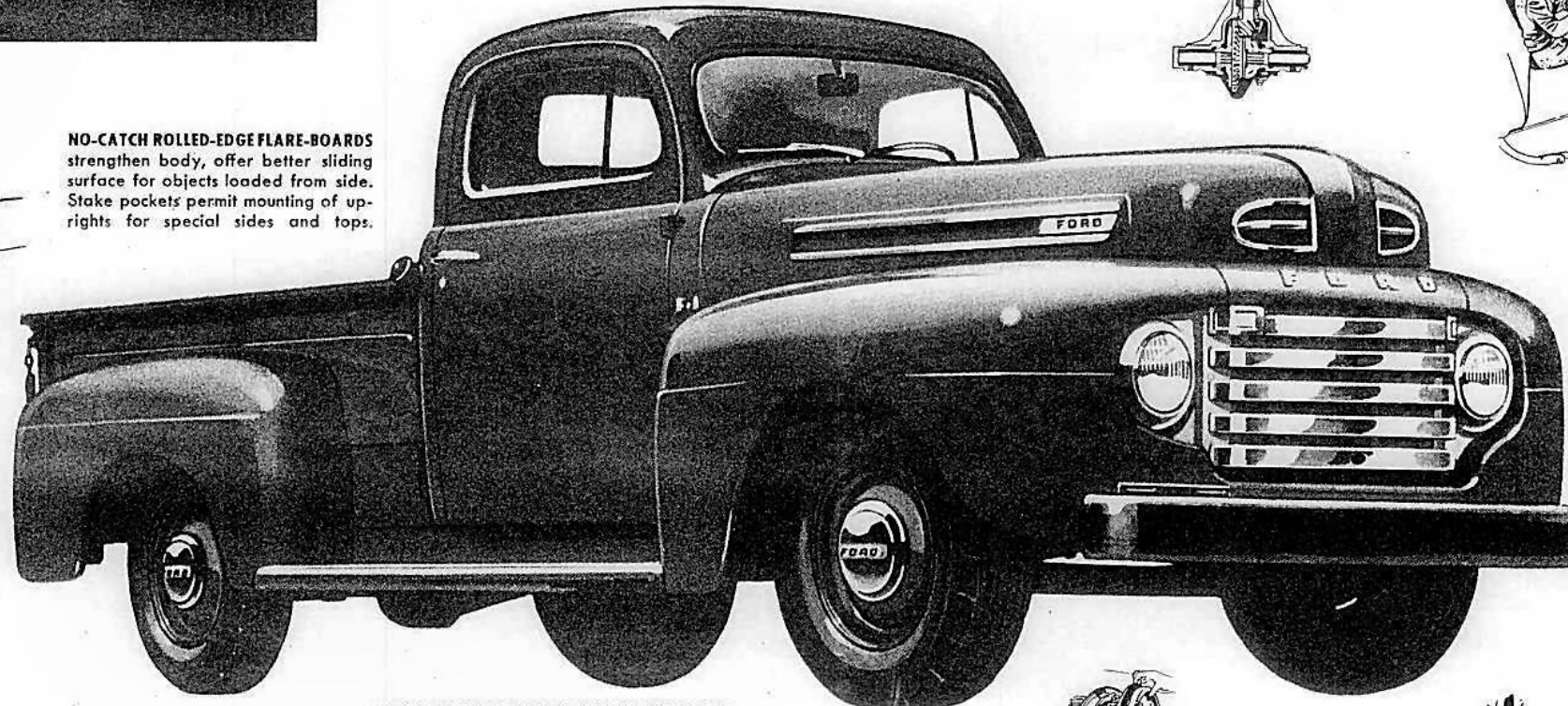

TAILGATE strengthened with tapered truss-type rolled edge. Anti-rattle drop-chains hold tailgate flush with floor or let it swing all the way down.



RIGHT-HAND WINDSHIELD WIPER AT EXTRA COST.

BIG BODY handles standard four feet wide building materials, long enough to carry average door. Capacity of 45 cu. ft. makes it one of biggest Pickups in the half-ton field.

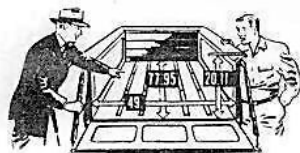

NEW FORE AND AFT STEERING for greater stability, more uniform response under variable conditions. Drag link and forward shackled springs follow similar arcs. Better steering geometry, easier control.

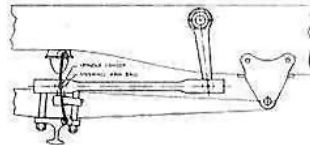

REMOVABLE BRAKE DRUMS simplify maintenance. Drum can be bought separately from hub for replacement.

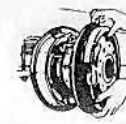

The 45 cu. ft. body capacity makes the F-1 Pickup one of the biggest in the half-ton field. Big load width of over four feet gives the F-1 Pickup an amazing range of use. The new Rouge 226 Truck Six has performance galore. With standard 3.73 to 1 axle, 6.50-16 tires, gross load of 4,700 lbs. including 1,450 lbs. payload, it pulls a 10% smooth concrete grade in high, better than 30% grade in first. Engine speed at 35 m.p.h. is an economical 1,600 r.p.m. An optional 4.27 to 1 rear axle ratio steps up pulling ability approximately 14%. Truck operators choose the 3.73 rear axle ratio for economy, the 4.27 axle ratio for extra pulling ability.

ENGINEERING HIGHLIGHTS—NEW F-1 PICKUP

NEW ROUGE 226 TRUCK SIX—New, longer 4-ring Flightlight pistons save oil—Main and connecting rod bearings are replaceable-type—Series-flow cooling with thermostatic control—Alloy exhaust valve seat inserts give longer wear—Improved intake manifold for higher efficiency—New Loadomatic spark control for more power, more economy—New Rouge 239 Truck V-8 Available. **CHASSIS**—New Feather-Foot brakes for true and easy stopping—Needle bearing steering eases control—Flat tube and fin radiator for greater durability—New airplane-type shock absorbers, front and rear—Gyro-Grip clutch multiplies grip with increased speed.

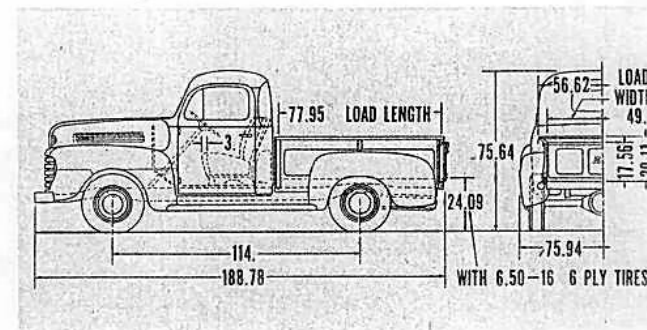

This Packet
Contains all the News
of the
NEW 1948 LINE
of
FORD MOTOR TRUCKS

The First New
POST-WAR PRODUCTS
of the
FORD MOTOR COMPANY

Please Observe the RELEASE DATE
FRIDAY, JANUARY 16, 1948

FROM FORD NEWS BUREAU
Administration Building
DEARBORN, MICHIGAN

RELEASE FRIDAY, JAN. 16, 1948

Driver comfort and efficiency were among the primary considerations of engineers and designers who created the 1948 Ford trucks, shown to the public for the first time today by Ford Motor Company dealers in the United States.

The new models represent Ford's first post-war product.

Cabs for the new trucks have been redesigned to assure living room comfort. They provide seven inches greater width as well as increased headroom. The door opening has been moved forward three inches, providing greater clearance for entering and leaving the cab.

The doors extend well below the floor and are weather-sealed for protection against moisture, dust and drafts. Interior and exterior hardware is more rugged.

A one-piece windshield which is two inches higher gives drivers clearer vision forward. The rear window has been enlarged to increase visibility.

Seats and cushions give passenger car comfort to driver and helper. The adjustable coach-type seat has individually wrapped coil springs and a rubberized hair pad. The cabs also have a large ash tray, dispatch box and sun visor. Provision for radio installation includes a grille opening in the instrument panel.

The new cabs also provide for a new three-way air control system to assure high-volume, fresh-air ventilation.

Engineers increased the steering ratios on the 1948 Ford trucks to provide easier handling. The light trucks are equipped with new direct-action shock absorbers. Two-ton and heavier models are equipped with vacuum power brakes.

FROM FORD NEWS BUREAU
Administration Building
DEARBORN, MICHIGAN

RELEASE FRIDAY, JAN. 16, 1948

A new line of Ford trucks is being shown to the public for the first time today by Ford Motor Company dealers throughout the nation. The streamlined 1948 models, completely new from the wheels up, represent the first post-war product of Ford.

J. D. Ball, director of the truck and fleet sales department, said the new trucks are notable for an unprecedented range of models and capacities as well as many engineering changes.

Two new series -- F-7 and F-8 -- are the largest ever manufactured by Ford. They have maximum gross vehicle weights of 19,000 and 21,500 pounds, respectively. Another new series is the six-cylinder cab-over-engine model.

Three new power plants are available for the new trucks -- a 95-horsepower six-cylinder engine, a 100-horsepower V-8, and a 145-horsepower V-8.

The new trucks are attractively styled without losing ruggedness necessary for good performance and long life. Radiator grille and headlights are recessed in a functional pattern in the modern front end which contributes to massive appearance and gives added protection.

Greater front end strength has been achieved through improved sheet-metal suspension and heavier construction. Fenders are heavier, wider and of a new design which provides greater tire clearance. Another design advancement is a heavy channel-steel front bumper attached directly to extended frame side rails. The bumper is, in effect, an extra cross member providing greater rigidity and impact strength.

Driver comfort is one of the first considerations in the new trucks. Advanced cab design provides living room comfort with more space and better ventilation.

The new cabs provide up to seven inches greater width and also more headroom. The door has been moved forward to provide better clearance when leaving and entering. Weather-proofing has been improved and the hardware is heavier.

A one-piece windshield provides increased visibility. The rear window has been enlarged. Other cab improvements include new coach-type seats with improved cushions, ash tray, dispatch box, sun visor and a three-way air control system.

The complete line of 1948 trucks includes: The nominally rated half-ton series of 114-inch wheelbase with a deluxe delivery model and standard pickup, panel and stake bodies; three-quarter ton regular and heavy-duty series, 122-inch wheelbase with express and stake bodies; one-ton, 134-inch wheelbase series with stake body and single or dual rear tires available; one and one-half-ton heavy-duty series with 134 and 158-inch wheelbase.

One and one-half-ton heavy-duty cab-over-engine series with 110, 134 and 158-inch wheelbase; two-ton heavy-duty of 134 and 158-inch wheelbase; two-ton heavy-duty cab-over-engine series of 110, 134 and 158-inch wheelbase; 30 to 36-passenger school bus chassis with 158-inch wheelbase.

Forty-two to 48-passenger school bus chassis with 194-inch wheelbase; the extra-heavy-duty two and one-half-ton on 135, 159 and 195-inch wheelbase and the three-ton on the same wheelbase lengths.

FROM FORD NEWS BUREAU
Administration Building
DEARBORN, MICHIGAN

RELEASE FRIDAY, JAN. 16, 1948

Three new power plants have been announced by the Ford Motor Company for the 1948 trucks, viewed for the first time today in the showrooms of Ford dealers throughout the country.

These engines are the Rouge 226, a completely new six-cylinder, 95-horsepower truck engine; the Rouge 239, an improved V-8 100-horsepower engine, and the Rouge 337, a new heavy duty V-8 power plant developing more than 145 horsepower for the largest trucks ever built by Ford.

All engines have heavy-duty oil bath air cleaners, pressure-sealed cooling systems, and new weather-proofed ignition systems with automatic spark control which is regulated by engine load and speed.

The three engines also have new distributors and wiring, conveniently located for easy servicing. Valve springs are shot-blasted and rust-proofed. The valve seat inserts are of hard molybdenum chrome alloy. The precision type crankshafts are oversize, as are the connecting rod bearing inserts.

Higher capacity generators deliver maximum output at low engine speeds and there is a new high-volume replaceable-element oil filter.

A feature of the new Ford six-cylinder engine is the aluminum alloy pistons which are longer and plated to resist wear. These pistons have four rings above the wrist pin for maximum oil economy and minimum friction losses. The compression ratio, 6.8 to 1, produces more power and a new high-lift camshaft opens valves wider and faster, resulting in more efficient intake and exhaust.

The 100-horsepower engine now has accessories conveniently grouped on top for easy servicing as well as many other new features.

Features of the 145-horsepower power plant include hydraulic valve lifters which automatically compensate for valve wear and insure quiet operation.

Silichrome exhaust valves are faced with one of the toughest metals known.

A governor has been built into the carburetor and operates from engine speed and vacuum. This engine, designed for the new "big jobs," develops 255 pound feet of torque.

Many other new engineering features have been included in the new trucks. Steering ratios have been increased for easier handling.

Greater rigidity has been achieved in the frames by extending the side rails to which are attached the heavy channel steel front bumper. Frames on the F-7 and F-8 series are nine inches in depth with sturdy alligator jaw cross members.

Clutches on the larger trucks are 12 inches in diameter, capable of easily handling the peak torque output of the 145-horsepower engine. These trucks also have five-speed transmissions. The F-7, with maximum gross vehicle weight of 19,000 pounds, has a single speed heavy duty hypoid axle. The F-8, with a gross vehicle weight of 21,500 pounds, has a two-speed axle, making 10 speeds available for all types of roads and loads.

The new Ford light trucks have direct action shock absorbers. Wider axles permit shorter turning and ample chain clearance. Straight through mufflers reduce back-pressure, improving engine performance.

Two-ton and heavier models are equipped with vacuum power brakes. Another new feature of the new line is wider base wheel rims with tapered tire bead seats.
