

They take you
3-ways ahead

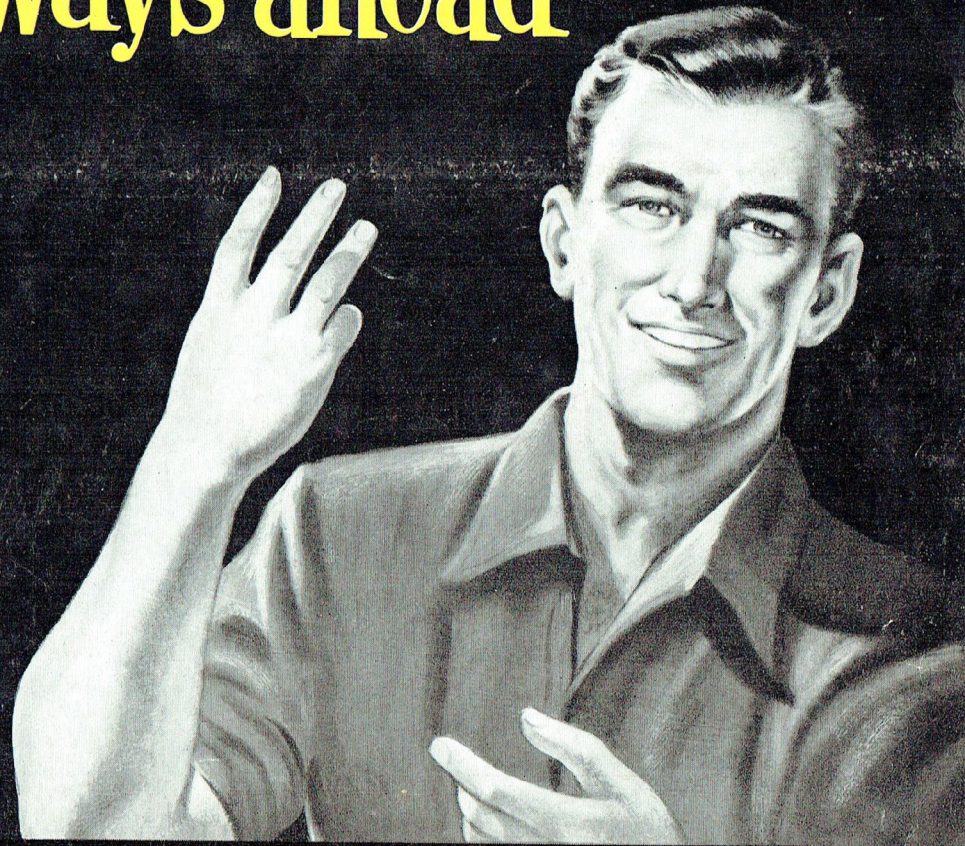
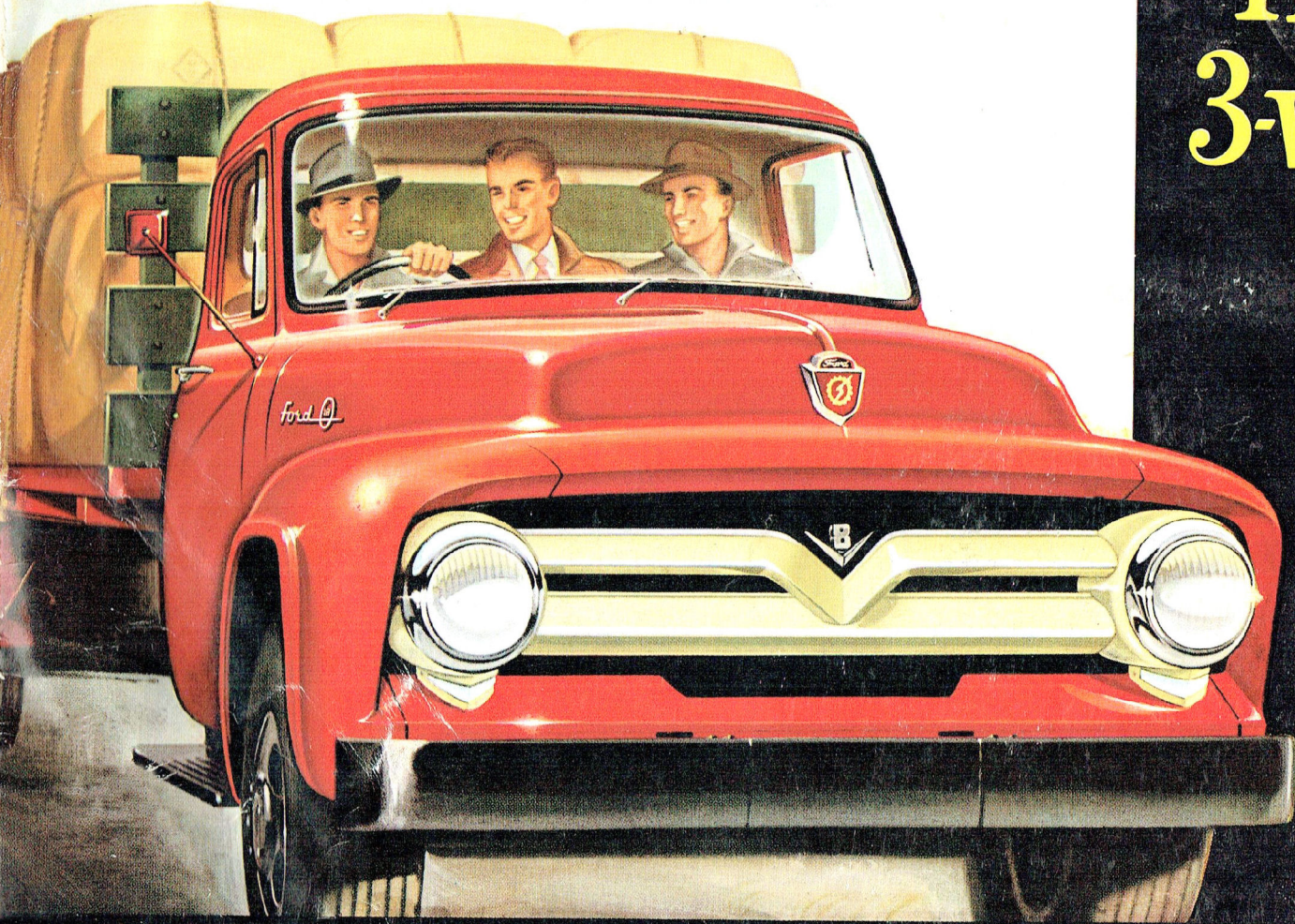

FORD O.H.V. **TRUCKS,**
V8 *TRIPLE ECONOMY*

What Ford Truck

triple economy

means to you—

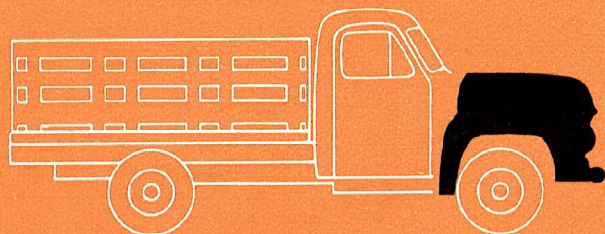

Money-saving **POWER**

Ford's new Overhead Valve V8 truck engine gives you more sustained torque and big power reserves to handle your payloads more economically and with greater ease. Ford's modern Y-block, low-friction design means longer engine life, lower maintenance costs. In the new Ford O.H.V. V8 Truck engine you find Big Economy Item No. 1!

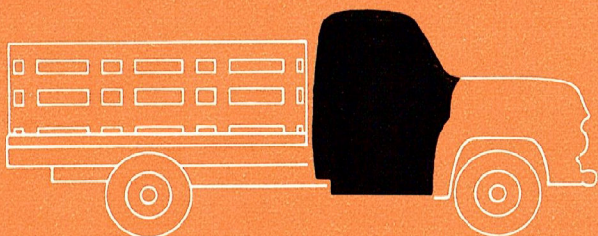

Driver-saving **EFFICIENCY**

Ford's cab design—with its big 3-man capacity—is the greatest comfort feature ever enjoyed by men who make their livings in the transport business. Behind the wheel the driver finds ease and convenience which conserve his energy, save time, lessen fatigue, increase his working capacity, make his job happier. And that's Big Economy Item No. 2!

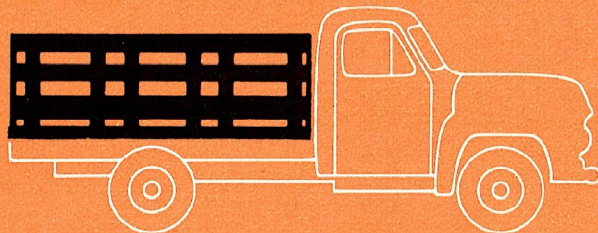

Cost-saving **CAPACITIES**

Whatever may be your particular needs, you'll find the right load-carrying capacity in the range of new Ford Trucks. You'll find, too, that Ford's designing has given you a chassis built for easy, practical, low-cost installation of any standard or specialised body type you need. Ford's profitable payload capacity is Big Economy Item No. 3!

*adding
up to*
**MORE
TRUCK
FOR
YOUR
MONEY**

APPEARANCE, SAFETY with COMFORT for the driver

"LOOK GOOD AND FEEL GOOD" that is the summing up of the outstanding advances Ford has made in truck cab design. They go far beyond the extra smartness that makes a Ford Truck such a good-looking representative of any business. Every factor affecting driver-fatigue has been given careful attention . . . to give him new comfort . . . to help him work more efficiently. Unlimited vision, spacious

door openings, loads of room (plenty of leg, shoulder and hip space for three big men), conveniently located controls, push-button door handles, deeply sprung adjustable seat, complete weather-sealing . . . even positioning of driver and passengers mean more comfort. Front axle location means that they ride closer to the more resilient front springs and farther away from the stiffer, load-carrying rear suspension!

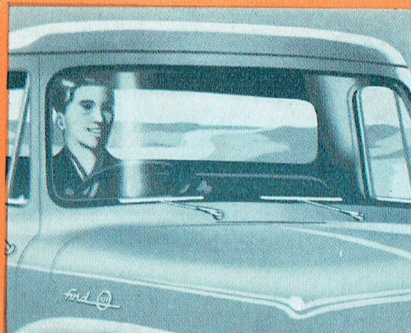
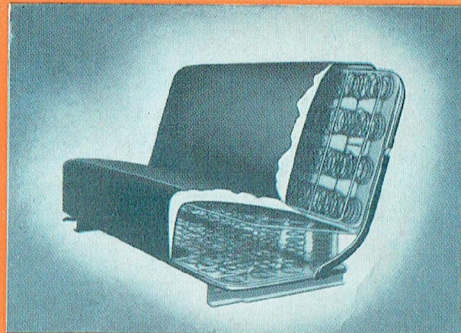
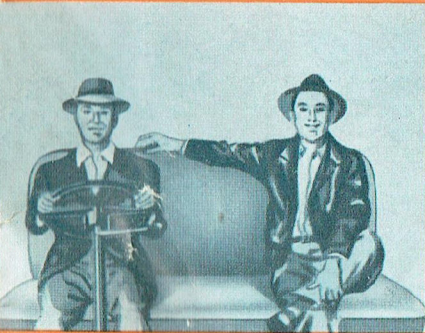
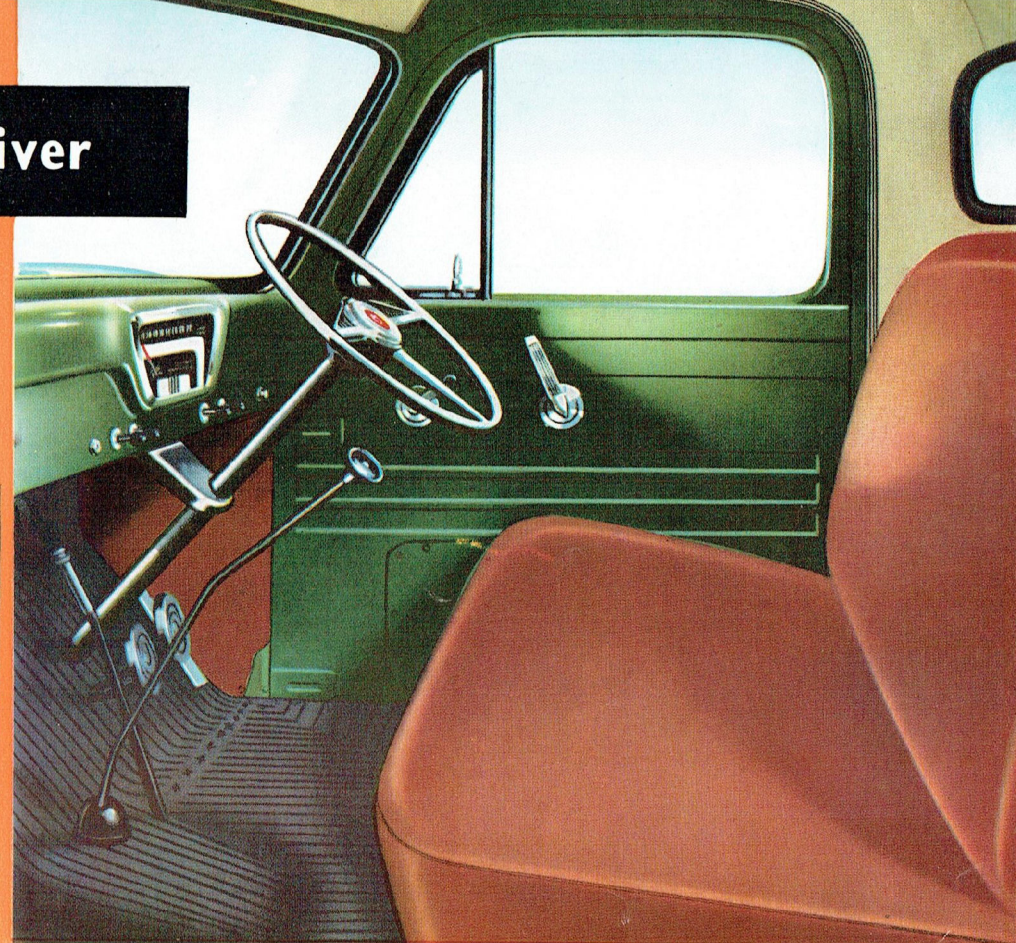

Great roominess . . . in width-room, leg-room, head-room, Ford cabs provide plenty of relaxing space for three big and tall men.

Wide-comfort seat . . . special construction and long-lived Vinyl upholstery resist hard usage . . . seat keeps shape, comfort lasts longer.

Huge windshield . . . one piece of curved glass with set-back pillars for over 938 sq. ins. of unobstructed, wide-spread vision.

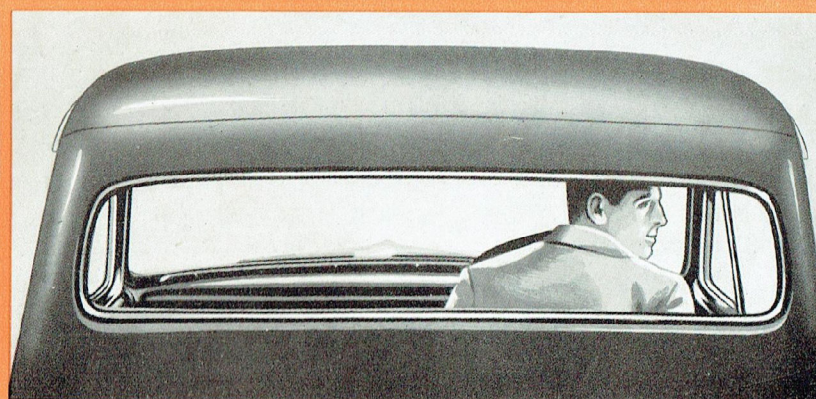
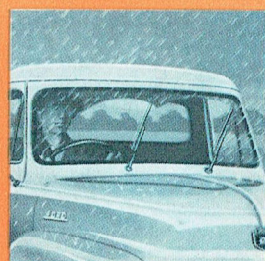

Big, wide doors
almost full yard wide for entry and exit ease.

Weather-sealing
at all points keeps out dust, fumes, moisture.

All instruments
in a compact cluster, can be read instantly.

Big-sweep wipers
keep wider vision area clear in bad weather.

Full-width rear window

Over 4 feet wide and with 448 sq. ins. glass area, this larger rear window aids in tight manoeuvring and backing. With large, curved one-piece windshield and deeper side windows, Ford V8 Trucks give all round clear angle visibility to a total of 294 degrees. This is another Ford contribution to road safety and driver's ease.

New and mighty

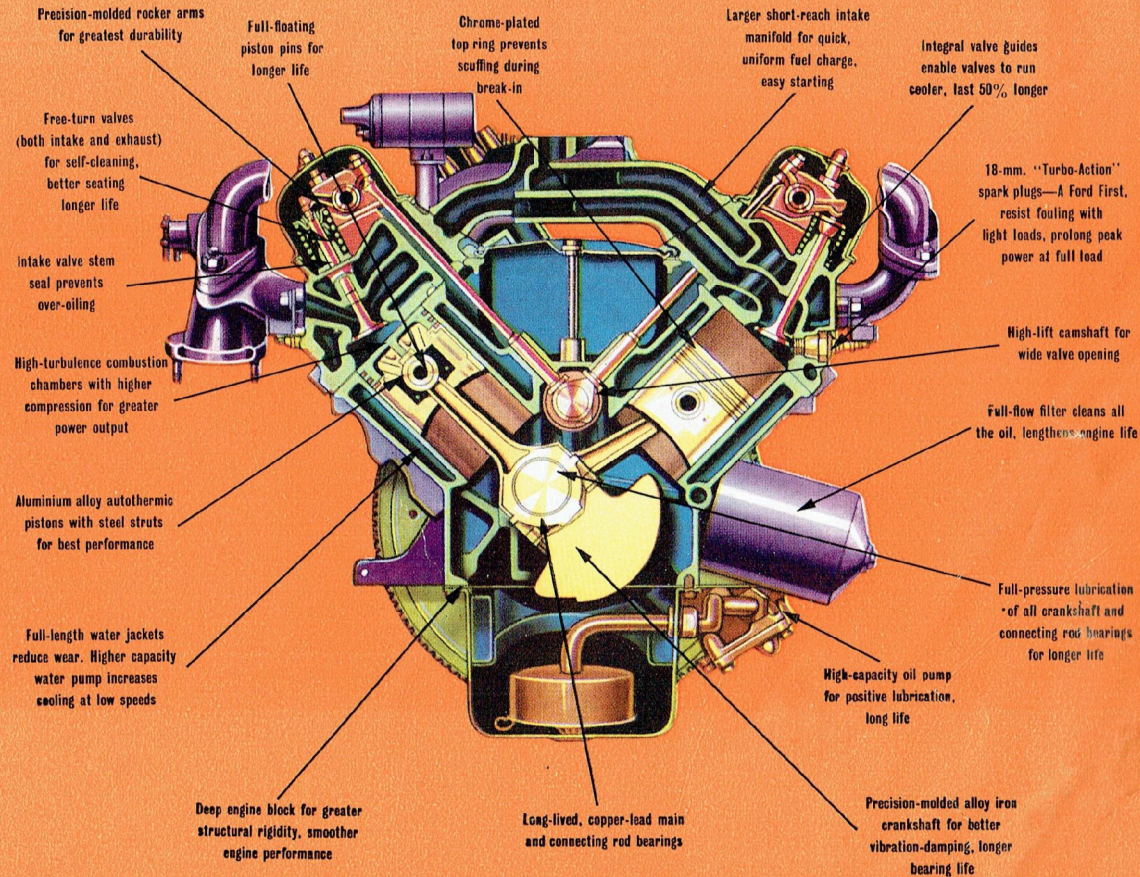
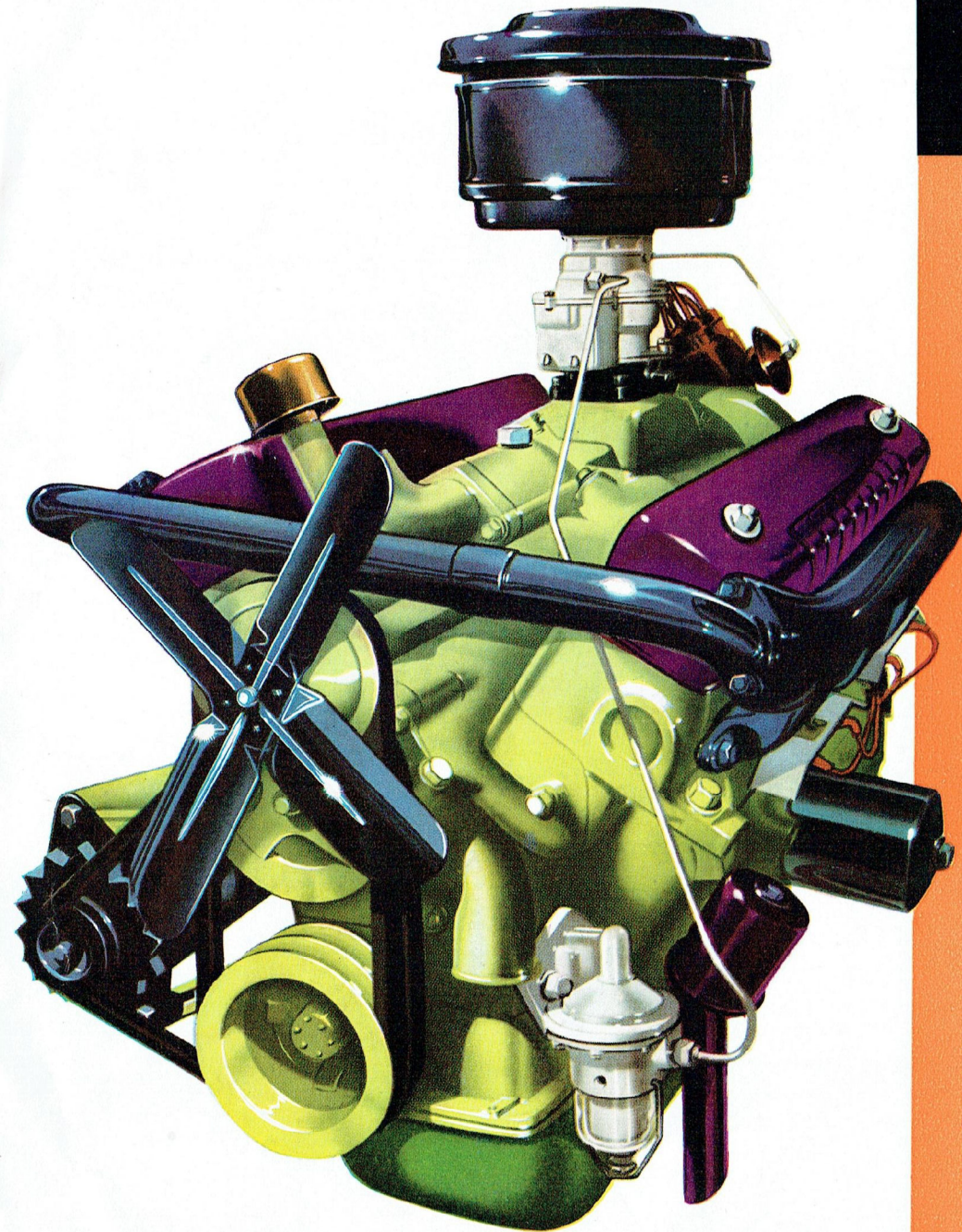

This is Ford's Greatest Ever Truck Engine

And that simple phrase speaks volumes, for Ford V8 engine performance is known and respected wherever, the world over, transport work is on an efficient, must-earn-profits basis. Ford has built more V8 engines than all other makers combined and the new Overhead Valve V8 engine is the culmination of all of this unrivalled experience. It develops far more horsepower per cubic

inch displacement. Its Y-block design, deep-skirt integral crankcase and wide-base fly-wheel housing give higher structural rigidity. Its short piston-stroke reduces internal friction waste, liberating more power to the clutch with consistent petrol economy. This new O.H.V. V8 will give you greater power, more of the sustained, all-speed torque needed in tough work, longer life and lower maintenance costs. In short, it is a new mighty powerful reason why Ford means more truck for your money.

Y-Block O.H.V. V8 Truck Engine

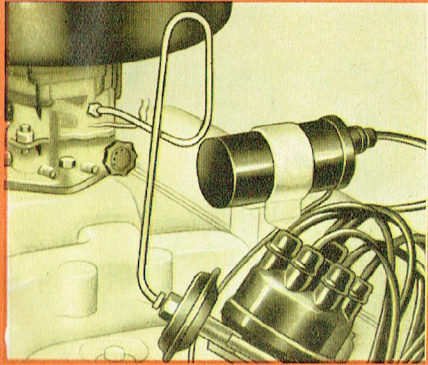

Automatic Power Pilot. Through single vacuum control which automatically co-ordinates carburettor and distributor, this exclusive Ford feature makes certain that the right petrol mixture is ignited at the right instant and is burned completely to give most "go" and economy from every drop of petrol.

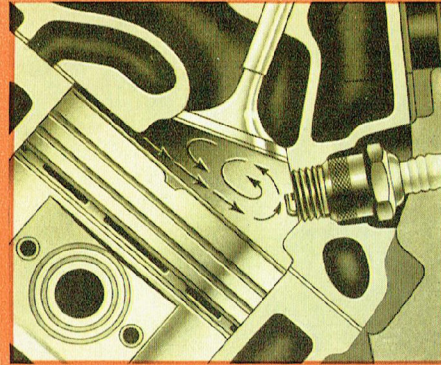

High-Turbulence combustion. Wedge-shaped combustion chambers provide a large "squish" area which creates high-turbulence in the fuel-air mixture, giving more complete and efficient combustion without detonation, higher power output and greater thoroughness in scavenging of exhaust gases.

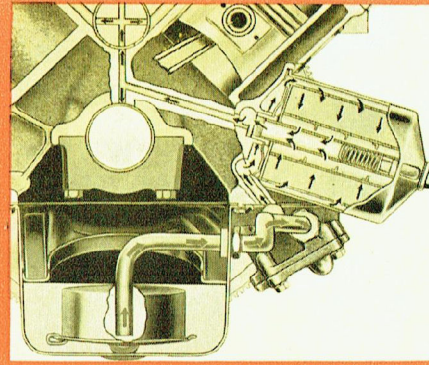

Full-flow oil filter cleans all oil before it reaches bearing surfaces, reducing cylinder wall and piston ring wear and contributing to long bearing and engine life. High capacity oil pump is of efficient gear type for positive discharge, quiet operation, long life and has integral pressure-regulating valve.



High-lift quiet-contoured camshaft of special iron-alloy with high resistance to wear has cam contours of high-lift design to open valves wide. This ensures that full charges enter cylinder and exhaust gases escape easily.

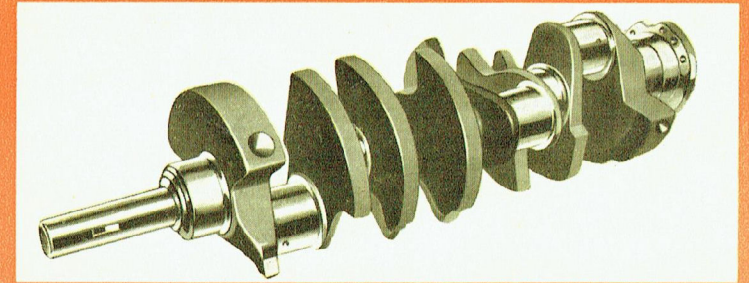

Exceptionally rigid crankshaft is cast by an exclusive Ford method from a special, wear-resisting iron-alloy and has 5 main bearings and 8 integral counterweights and is typical of Ford V8 Trucks' precision engineering.

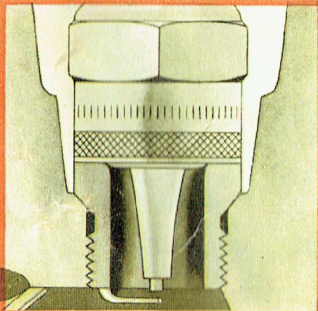

Turbo-action plugs

Tapered seating forms positive lock in cylinder head without washer. The greater firing end clearance allows gases to keep insulator more free of deposits and extends the plug's heat range.

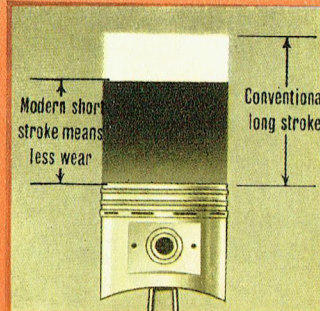

Low-friction design

Piston travel is actually less than the bore diameter . . . 3.62 in. bore . . . 3.10 in. stroke. This ratio results in shorter piston travel with much less friction between piston and the cylinder wall.

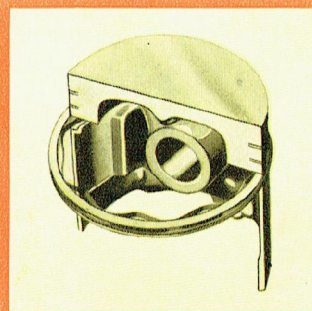

Super-fitted pistons

Flat head, autothermic design of lightweight aluminium alloy. 3 rings with chrome plating of top ring and phosphate-coated bottom ring has steel expander for closer, long-lasting oil control.

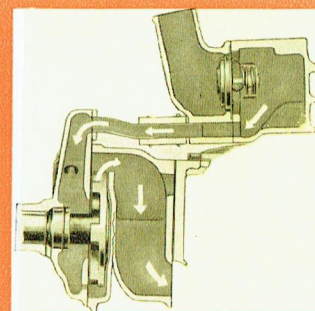

High Capacity Water Pump

increases the water flow, reducing over-heating possibility at low speed or idling. Positive-action thermostat, unaffected by varying pressures, constantly and dependably regulates coolant.

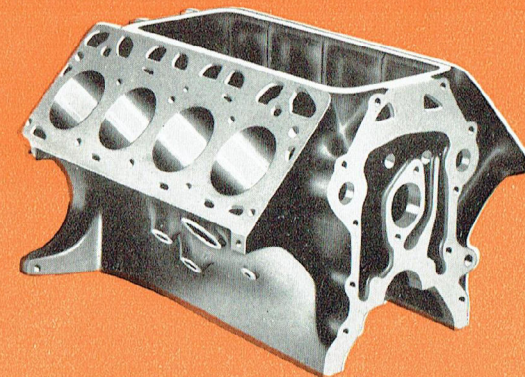

Y-block with its great rigidity means longer life, smoother operation. With deep-skirt crankcase it provides high resistance to distortion and wear. Crankcase extends well below the centre of the crankshaft giving greater structural rigidity and better oil-pan and crankcase seals. Block structure widens out at rear for very rigid connection of block and the flywheel housing.



**FORD
F100
FREIGHTER**

**GVW: 5,100 lbs.
Wheelbase: 110 ins.**

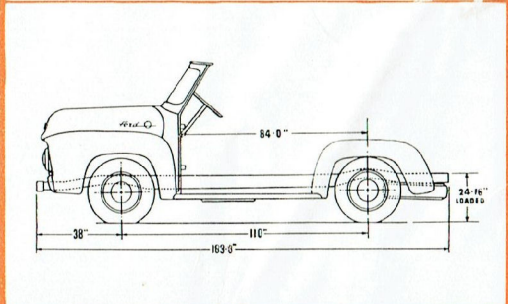
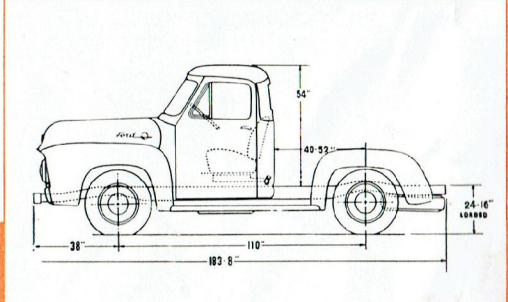
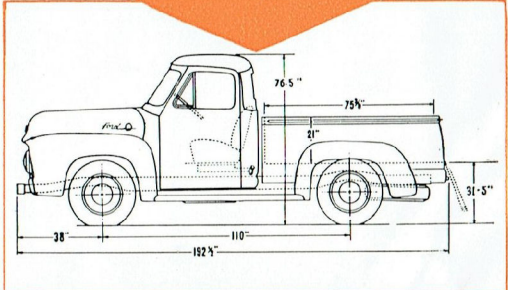

First choice for all-purpose utility service

Founded on the huskiness of the Ford F100 chassis, this smart, all-purpose vehicle is packed full of features which mean big strength, big convenience and big comfort. The utility space handles four-foot wide building material and is long enough for the average door. All steel body framing and panelling throughout ensure uniform strength and maximum rigidity. Reinforced top edges and double side panelling provide extra rigidity to take weight of bulky objects in side loading or unloading. The seasoned hardwood floor is bolted

in between seven longitudinal steel skid strips. Tailgate is all steel and when lowered, forms a convenient loading platform flush with floor and skid strips. The cab has wide-spread roominess for three people and has every comfort-giving, fatigue-saving feature of Ford's cab design. In its G.V.W. rating Ford F100 has unlimited applications. In addition to the complete Utility pictured above, it is available as either chassis and cab or chassis, windscreen and cowl, enabling the construction of any specialised type of body.

A GREAT CHASSIS BRISTLING WITH STRONG TRUCK-TYPE FEATURES

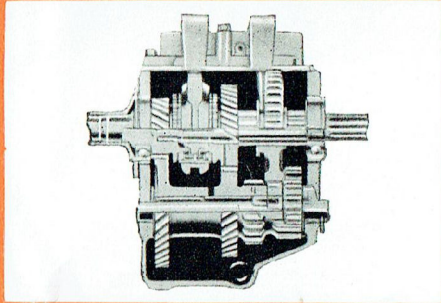

3-Speed Heavy-duty Synchro-Silent Transmission

with steering column gearshift, provides smoother, easier shifting . . . ideal for lighter type, heavy duty jobs. Helical gears and synchronisers in second and high speeds for quiet efficient operation and long service

Illustrated is the 110 inch W.B. F100 chassis

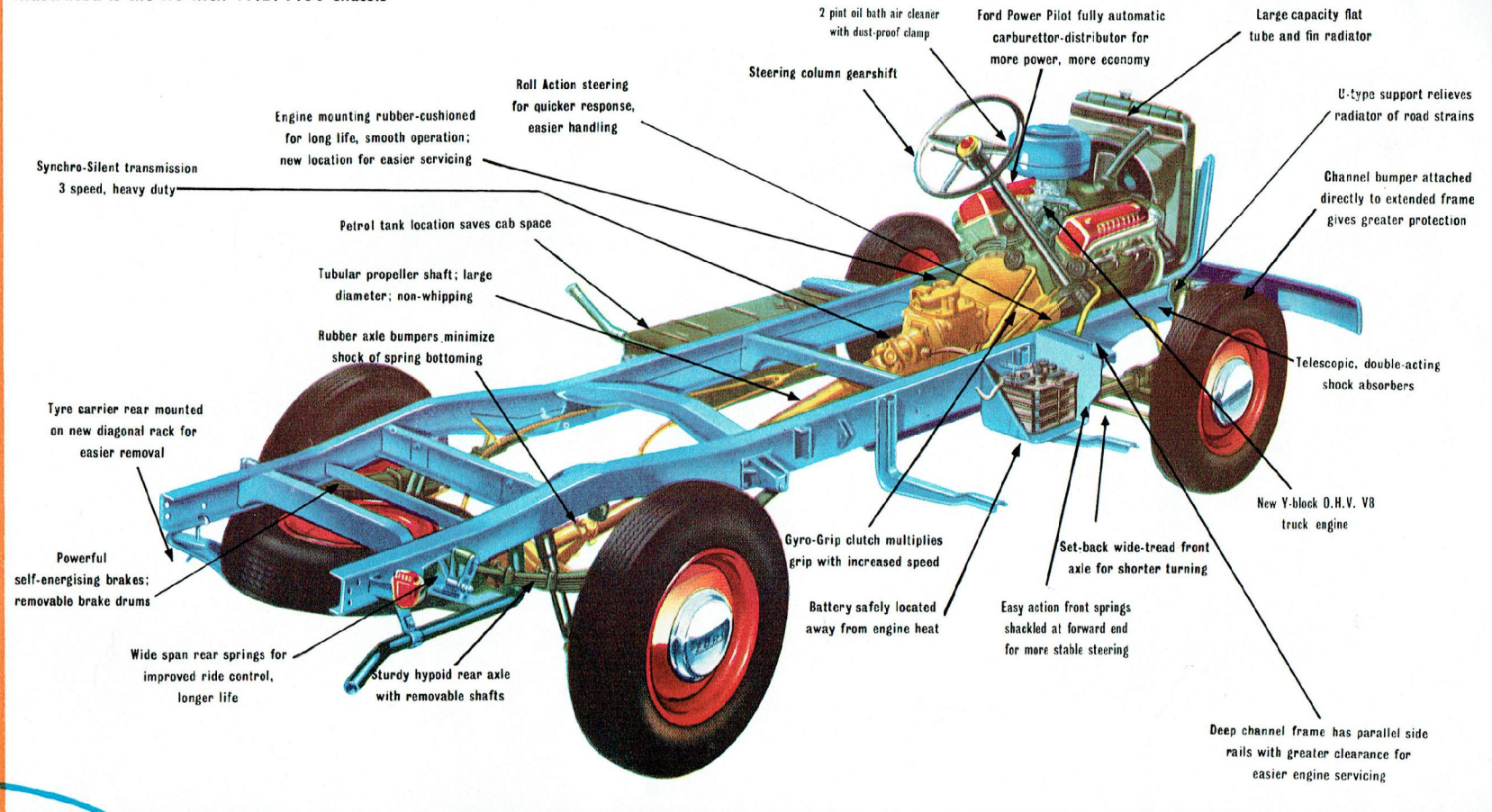

**FORD CHASSIS DESIGN
GIVES WORK-SAVING, TIME-SAVING
MONEY-SAVING MANOEUVRABILITY
AND HIGH EFFICIENCY**

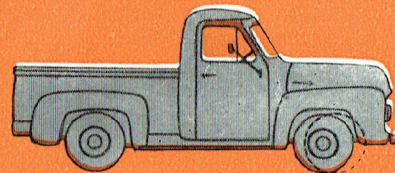

Wide Track, Set-Back Front Axles

The front axle is moved back providing a shorter wheelbase with greater manoeuvrability. Body load centre is moved forward and larger-capacity front axle supports a larger share of the load for better weight distribution. Wider track provides increased stability, and gives the greater handling ease of a turning angle of up to 39 degrees.

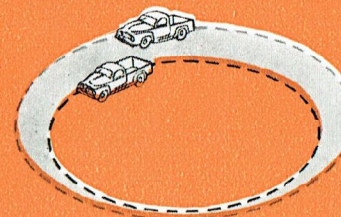

Shorter Turning

is the result of Ford's wider tread, shorter wheelbase design. Turning circle diameters have been reduced up to 6 feet. Shorter turning, plus more responsive steering provides easier handling under all conditions, and saves working time in deliveries.



Cushioned Ride Control

provides a softer, smoother ride for both the driver and the load. With shorter wheelbase, the driver sits closer to the smooth-riding front springs and farther from load-supporting, stiffer rear springs. Wide-span springing design cushions the bumps.

FORD F500

GVW 11,000 lbs.

Wheelbases: 130", 154"

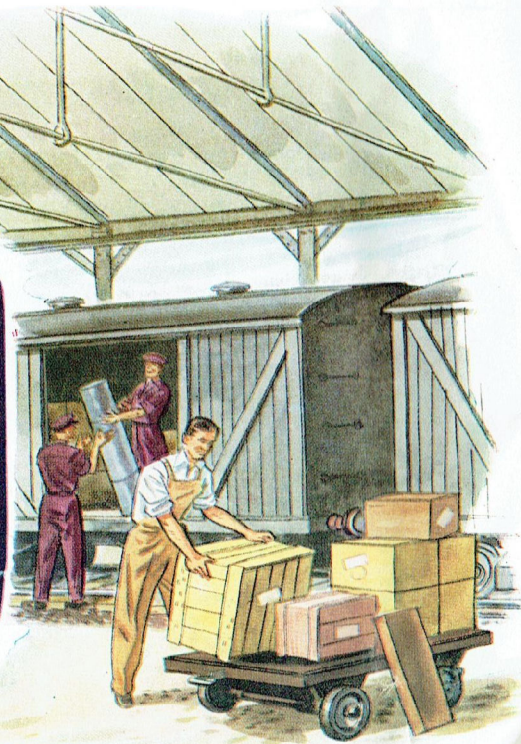

Designed for more deliveries per day

Mighty popular will be this Ford rating . . . bringing the easy working and cost-saving advantages of O.H.V. V8 power and the Ford Truck triple economy to versatile, medium-duty work. The extra manoeuvrability provided by shorter wheelbase and wider front track is one of its big advantages. The big driver-comfort of the Ford cab is yet another extra efficiency factor. In everything from extra visibility to easier exit and entry through wider door openings, the designing of Ford cabs lessens the driver's fatigue on continuous delivery runs. Driving control, too, is easier . . . there

is no tiring "double-clutching" with Ford's heavy-duty 4-speed Synchro-Silent transmission . . . "Roll-action" steering is lighter but more certain . . . advanced Gyro-grip clutch needs less operating pressure . . . Ford's self-energising hydraulic brakes mean safer stopping. Add to all this the longer life in every chassis feature from deep channel frame members to full floating axle—in each inch you see how Ford builds stronger to last longer. Reckon it all up and the man who wants to make money and save money in his job will have a multitude of reasons to choose Ford.

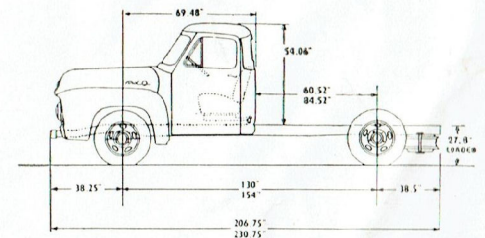

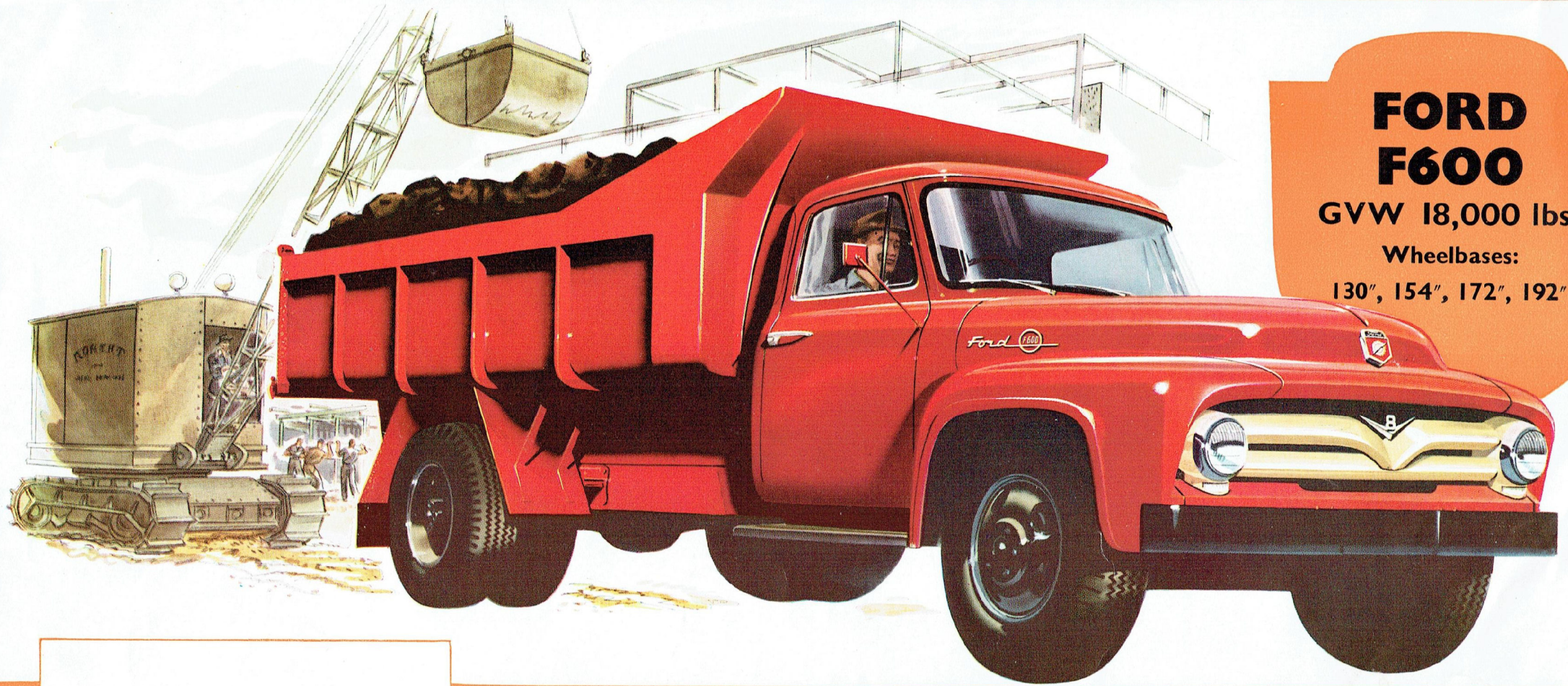

**FORD
F600**
GVW 18,000 lbs.
Wheelbases:
130", 154", 172", 192"

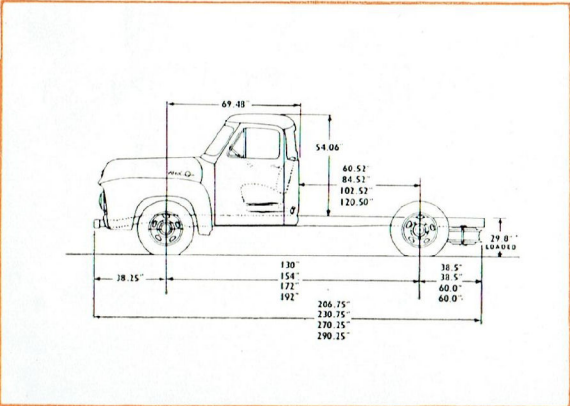

Australia's hardest-working truck

Advanced again is the truck famous wherever truck men work. Its new O.H.V. V8 low friction engine gives you EASY power when and where you need . . . instant, for quick getaways, sustained for long pulls under the heaviest loads. And this new engine's petrol economy is made consistent by Ford's exclusive "Power Pilot". A heavy-duty truck in every sense of the word, it is powerfully built throughout . . . Big, deep, double-channel chassis frame members . . . 2-speed, full-floating rear axle with straddle-mounted pinions and 4-pinion differential . . . Vacuum power braking with

removable brake drums for easier servicing . . . Heavy rear springs with 7-leaf auxiliaries . . . 11-inch Gyro-grip clutch that multiplies grip as speed increases . . . 4-speed Synchro-Silent transmission built for heavy hauling . . . Roll-action steering that reduces costly friction wear . . . Universal joints and centre bearings of needle-bearing type for longer life . . . Everywhere there's that Ford "built stronger to last longer" quality. And for the man who drives, and for those who ride with him, there are all the fatigue-saving and comfort features of Ford's big three man cab design.

FORD BUILDS STRENGTH RESERVES INTO EVERY PART

2-Speed Rear Axle . . . standard equipment on F600 model and provides eight forward and two reverse speeds to reconcile performance to load. The 6.33 to 1 spiral bevel single reduction is ideal for open country or light loads and saves on petrol and oil. For heavy loads or hill climbing a change to the 8.81 to 1 reduction provides maximum pull. Ford rear axles are full floating with straddle-mounted pinions and 4-pinion differentials. The axle housing carries the load, the shafts being left free to turn the wheels. Heavy duty roller bearings used throughout.

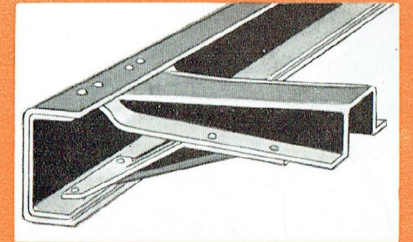
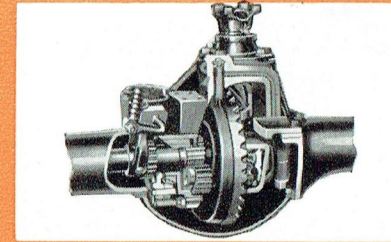

Double Channel Frame . . . with built-in section reinforcement extends past front and rear spring hangers for greater resistance to all torsional twist and strain.

Illustrated is the 192 inch W.B. F600 chassis

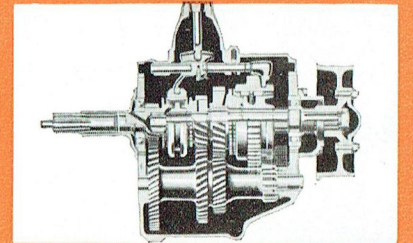
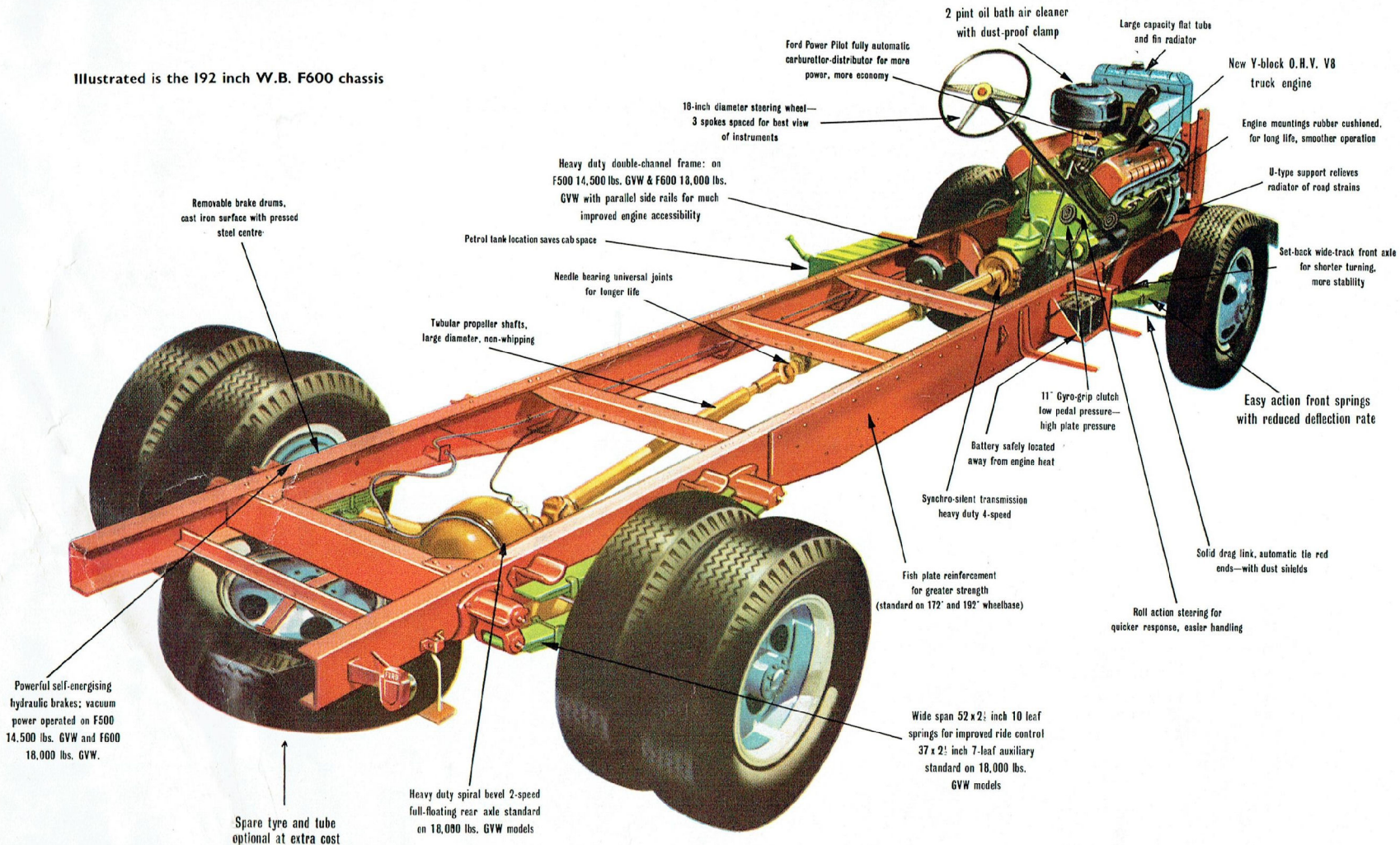

4-Speed Synchro-Silent Transmission is engineered for quiet operation, easier shifting, longer life. Eliminates "double-clutching", provides more safety in down shifting. One-piece clutch and flywheel housing provides smoother, more reliable power flow, more strength.

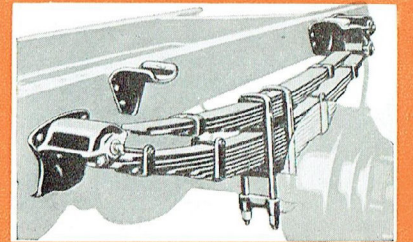

Wide-span Rear Springs provide easier ride for both heavy and light load conditions, front 45 inches, and 52 inches rear . . . with lower deflection rate to improve riding qualities and stability. 5-leaf auxiliary is standard equipment on the F500 with G.V.W. of 14,500 lbs. F600 has 7-leaf auxiliary.

ABRIDGED SPECIFICATIONS—FORD V8 TRUCKS

Unless otherwise annotated specification detail applies to all models in the range

AXLE, FRONT

Type: Reverse Elliott Modified I-Beam.

Material: Heat-treated Alloy-Steel Forging.

AXLE, REAR

Type: Single-speed, semi-floating (F100—GVW 5100 lbs.); Single-speed, full floating (F500—GVW 11000 lbs., 14500 lbs.); Two-speed, full floating (F600—GVW 18000 lbs.). **Gears:** Hypoid (F100—GVW 5100 lbs., F500—GVW 11000 lbs., 14500 lbs.); Spiral Bevel, Single-reduction Spiral Bevel plus Spur Planetary Set for Double Reduction (F600—GVW 18000 lbs.). **Axle Ratios: F100** (GVW 5100 lbs.) 3.92 : 1, **F500** (GVW 11000 lbs., 14500 lbs.) 6.2 : 1, **F600** (GVW 18000 lbs.) (2-Speed) 6.33 : 1 High; 8.81 : 1 Low. **Two Speed Shift.** Gear Shift Controlled, Power-operated (F600—GVW 18000 lbs.). **Axle Shaft Diameter at Spline: F100** (GVW 5100 lbs.) 1.24"; **F500** (GVW 11000 lbs.) 1.625"; **F500** (GVW 14500 lbs.) 1.625"; **F600** (GVW 18000 lbs.) 1.75". **Lubrication Capacity: F100** (GVW 5100 lbs.) 3 pints; **F500** (GVW 11000 lbs.) 11.25 pints; **F500** (GVW 14500 lbs.) 11.25 pints; **F600** (GVW 18000 lbs.) 10.8 pints.

BRAKES, SERVICE

Type: F100 (GVW 5100 lbs.) Hydraulic, Two-Shoe, Single-Anchor, Self-Energising. **Front Brake**—(Drum Diameter and Lining Width—thickness) 11" x 2"—3/16". **Rear Brake**—(Drum Diameter and Lining Width—thickness) 11" x 1-3/4"—3/16". **Total Area**—(Drum Lining: 178.64 sq. inches). **Type: F500** (GVW 11000 lbs., 14500 lbs.); **F600** (GVW 18000 lbs.): Front—Single-Anchor, Self-energising. Rear—Hydraulic—Two cylinder independently anchored. **Front Brake**—(Drum Diameter x Lining Width—Thickness) 13" x 2 1/4"—1/4". **Rear Brake**—(Drum Diameter x Lining Width—Thickness) 15" x 4"—3/8". **Total Area**—Drum Lining 366 sq. ins. **Booster:** Type, Vacuum assisted (F500—GVW 14500 lbs.; F600—GVW 18000 lbs. only) 8 1/2" Effective Diameter.

BRAKE, HAND

F100 (GVW 5100 lbs.): Cable with Equalizer Applying Rear Wheel Brakes. **F500** (GVW 11000 lbs. GVW 14500 lbs.) and **F600** (GVW 18000 lbs.) External Operating on Transmission.

CLUTCH

Type: Gyro-Grip, Semi-Centrifugal, Single-Plate. **Diameter Outside:** 11 inches. **Total Frictional Area:** 123.7 sq. ins.

COOLING SYSTEM

Capacity: 19 quarts. **Radiator:** Flat Tube and Fin-Pressure Cap. **Thermostat:** In Engine Water Outlets. **Fan:** 4-Blade, Diameter 18 inches.

DRIVE LINE

Type: Hotchkiss Straight Line Drive.

ENGINE

Number of Cylinders—Bore and Stroke: 3.62 x 3.10 ins. **Displacement:** 256 cubic inches. **Compression Ratio:** 6.7 : 1.

FUEL SYSTEM

Carburettor: Dual Down-draught. **Air Cleaner:** Heavy Duty Oil Bath 2 pints capacity. **Fuel Pump and Filter:** Diaphragm Type, Driven from Camshaft. **Fuel Tank:** Capacity—**F100:** 14 galls., **F500, F600:** 16.5 gallons, outside left frame rail.

LUBRICATION

Engine: Full pressure feed to all main crankpin and Camshaft Bearings. **Oil Filter:** Replaceable Cartridge Type. **Crankcase Capacity:** 8 pints (dry) (plus 1 pint Filter Absorption). **Chassis:** Fittings for pressure lubrication.

ELECTRICAL SYSTEM

Battery: Heavy Duty 6 Volt. **Generator:** 34 Amp. **Ignition:** Full Vacuum Controlled System Fully Automatic. **Distributor:** Metal Clad Open Wiring in Rubber Grommets. **Head Lights:** Sealed Beam, Foot

Switch, Beam Control. **Starter:** High Torque, Automatic Engagement, Solenoid Switch, Push Button Control. **Parking Lights:** Combination Stop and Tail Light, Instrument Lights, Ignition Switch and Key Lock.

FRAME

Side Rail, Type: F100 (GVW 5100 lbs.). Parallel Channel Side Rails with Heavy Duty Cross Members. **Type: F500—GVW 11000 lbs.** Heavy Duty Single Channel Section. **F500—GVW 14500 lbs.** **F600—GVW 18000 lbs.** Heavy Duty Double Channel. **Reinforcement: F500—GVW 14,500 lbs., F600—GVW 18000 lbs.** Specially formed channel inside Side Rail. **Cross Members:** Flanged "U" type with Alligator Jaw and Channel Sections.

SPRINGS

Semi-Elliptic, Alloy Steel: Front: F100 (GVW 5100 lbs.) 42" x 1 3/8", **F500** (GVW 11000 lbs., 14500 lbs.) 45" x 2", **F600** (GVW 18000 lbs.) 45" x 2". **Rear: F100** (GVW 5100 lbs.) 52" x 2", **F500** (GVW 11000 lbs.) 52" x 2 1/2", **F500** (GVW 14500 lbs.,) 52" x 2 1/2", **F600** (GVW 18000 lbs.) 52" x 2 1/2". **Main Auxiliary: F500** (GVW 14500 lbs.) 37" x 2 1/2", **F600** (GVW 18000 lbs.) 37" x 2 1/2".

STEERING

Type: Worm and Dual Row Needle Bearing Roller. **Ratio:** 18.2 : 1 (F100—GVW 5100 lbs.) 20.4 : 1 (F500—GVW 11000 lbs. 14500 lbs., F600 GVW 18000 lbs.). **Wheel:** 18" Diameter, 3-spoke.

TRANSMISSION

Type: F500 (GVW 5100 lbs.): 3 speed Heavy Duty, Helical Synchronizers, 2nd and High with steering column gear shift lever. **Gear Ratios: F100** (GVW 5100 lbs.) Ratio to 1: 1st 3.71: 2nd 1.87: High 1.00: Reverse 4.59. **Lubricant Capacity:** 4.5 pints. **Type: F500** (GVW 11000 lbs. 14500 lbs.). **F600** (GVW 18000 lbs.) 4-Speed synchronous, Floor Change. **Gear Ratios: F500** (GVW 11000 lbs., 14500 lbs.). **F600** (GVW 18000 lbs.) Ratio to 1: 1st 6.40: 2nd 3.09: 3rd 1.69: High 1.00, Reverse 7.82. **Lubricant capacity:** 6.5 pints. **Power Take Off Opening—S.A.E.** 6-bolt on right side.

WHEELS AND TYRES

Wheels—F100 (GVW 5100 lbs.): 16 x 4 1/2 K Steel Disc. **Tyres:** 6.50 x 16—6-ply Truck Type, Front, Rear and Spare. **Wheels—F500** (GVW 11000 lbs.): 5.0 x 20 Steel Disc.

Tyres: 6.50 x 20—6 ply: 6.50 x 20—8 ply (Opt. extra cost) (7 wheels 6 tyres supplied standard). **Wheels—F500** (GVW 14500 lbs.): 6.0 x 20 steel disc. **Tyres—7.50 x 20—8 ply: 7.50 x 20—10 ply** (Opt. extra cost) (7 wheels 6 tyres supplied standard). **Wheels—F600** (GVW 18000 lbs.): 6.0 x 20 steel disc. **Tyres—8.25 x 20—10 ply.** (7 Wheels 6 Tyres Supplied Standard).

CHASSIS EQUIPMENT

Included as standard, in addition to items mentioned above: Hood, Cowl and Dash Assembly; Front Fenders; Centre Cowl Ventilator; Steel Toe Board; Instrument Panel; Speedometer; Water Temperature Gauge; Oil Pressure Gauge; Charge Indicator; Ash Receptacle; Glove Box; Hand Throttle (all models except F100 (GVW 5100 lbs.)); Light Switch; Electric Horn; Windshield Wipers; Treadle-type accelerator pedal; spare wheel; spare tyre carrier; spare wheel, tyre and tube standard on **F100—GVW 5100 lbs.**; bright hub caps; (F100—GVW 5100 lbs.) long arm outside rear view mirror on chassis cab; running boards; sun visor; standard tools in bag. On chassis cab and chassis, windscreen and cowl, rear fenders standard equipment on **F100—GVW 5100 lbs.**

GENERAL

	F100 (GVW 5100 lbs.)	F500 (GVW 11000 lbs.)		F500 (GVW 14500 lbs.)		F600 (GVW 18000 lbs.)			
			130"	154"	130"	154"	130"	154"	172"
Wheelbase	110"	130"	154"	130"	154"	130"	154"	172"	192"
Track, Front	60.60	62.75	62.75	62.75	62.75	62.75	62.75	62.75	62.75
Track, Rear	60.00	66.5	66.5	66.5	66.5	67.10	67.10	67.10	67.10
Max. Overall Length (to end of frame)	183.80	206.75	230.75	206.75	230.75	206.75	230.75	270.25	290.25
Max. Height (to top of Cab—Loaded)...	76.50	81.86	81.86	82.76	82.76	83.86	83.86	83.86	83.86
Max. Width of Vehicle (Bumpers) ...	76.76	77.6	77.6	77.6	77.6	77.6	77.6	77.6	77.6
Max. Length along Loading Floor ...	80.0								
Max. Width across Loading Floor ...	58.75								
Max. Width above Wheel Arches ...	59								
Max. Width inside Wheel Arches ...	48.0								
Across Loading Floor Max. Height of Sides from Loading Floor to Tonneau Cover	21.0								
Width of Tailgate Opening	50.0								
Width across Front Seat	56.70	56.70	56.70	56.70	56.70	56.70	56.70	56.70	56.70
Back of Cab to End of Frame	76.32	99.02	123.02	99.02	123.02	99.02	123.02	162.52	182.50

OWING TO THE VARIANCE OF BODY TYPES SPECIFICATIONS SUPPLIED ON REQUEST

FORD MOTOR COMPANY OF AUSTRALIA PTY. LTD.

(Incorporated in Victoria)

Registered Office: GEELONG, VICTORIA

Ford Motor Company of Australia Pty. Ltd., whose policy is one of continuous improvement, reserves the right, subject to such regulations as may from time to time apply, to change specifications and prices at any time without notice or incurring liability to purchasers.