

1 9 9 2

SEVILLE

ELDORADO

ALLANTÉ



FLEETWOOD

CADILLAC STYL

DEVILLE

BROUGHAM

S E C I



CADILLAC STYLE

## SUBSTANCE TAKES SHAPE, CADILLAC STYLE.

For 1992, the new culture that helped Cadillac become the first automobile company to win the coveted Malcolm Baldrige National Quality Award elicits even finer expressions of Cadillac luxury.



**T E C H N O L O G Y.** From Traction Control and Speed-Sensitive Suspension to anti-lock brakes and an electronically controlled powertrain, Cadillac



incorporates proven innovations that enhance performance, comfort and safety. Technology—not for technology's sake, but for yours.

**P E R F O R M A N C E.** The world leader in all-V8, all-ABS automobiles, Cadillac now offers Traction Control standard on more models than any other American automaker. The 4.9-liter V8, standard in most Cadillacs, develops 200 horsepower for spirited performance, and is balanced

by efficient highway mileage—an EPA-estimated 25 MPG highway. Cadillac continues to create a uniquely American balance of responsiveness and control.



**O W N E R S H I P.** Cadillac offers an outstanding portfolio of preferred ownership programs including the finest roadside service program of its kind, significantly enhanced for 1992, and Cadillac's 24-hour-a-day



Consumer Relations Center, making a Cadillac as comfortable to own as it is to drive.

- TECHNOLOGY  
2
- PERFORMANCE  
4
- COMFORT  
6
- SAFETY  
8
- CRAFTSMANSHIP  
12
- OWNERSHIP  
14
- SEVILLE  
16
- ELDORADO  
28
- ALLANTÉ  
40
- FLEETWOOD  
48
- DE VILLE  
58
- TOURING SEDAN  
64
- BROUGHAM  
70
- LIMOUSINES  
74
- SOUND SYSTEMS  
80

# TECHNOLOGY

## AMERICA'S HIGHEST QUALITY HONOR.

For the first time, an automobile company has earned the U.S. Government's highest quality honor: the Malcolm Baldrige National Quality Award. That company is Cadillac. The honor has recognized an intense dedication to a new culture of quality. The legacy now drives Cadillac to even greater product refinement and continuous improvement. The 1992 Eldorado and Seville are cases in point. Both are born of intense passion and simultaneous applications of meticulous engineering disciplines.

## THE LEADERSHIP OF TRACTION CONTROL.

Cadillac offers Traction Control standard on more models than any other American automaker. With it, the advanced anti-lock braking technology that helps bring your Cadillac to a controlled stop improves its traction during acceleration as well. Through Traction

Refer to individual car line sections for feature availability.

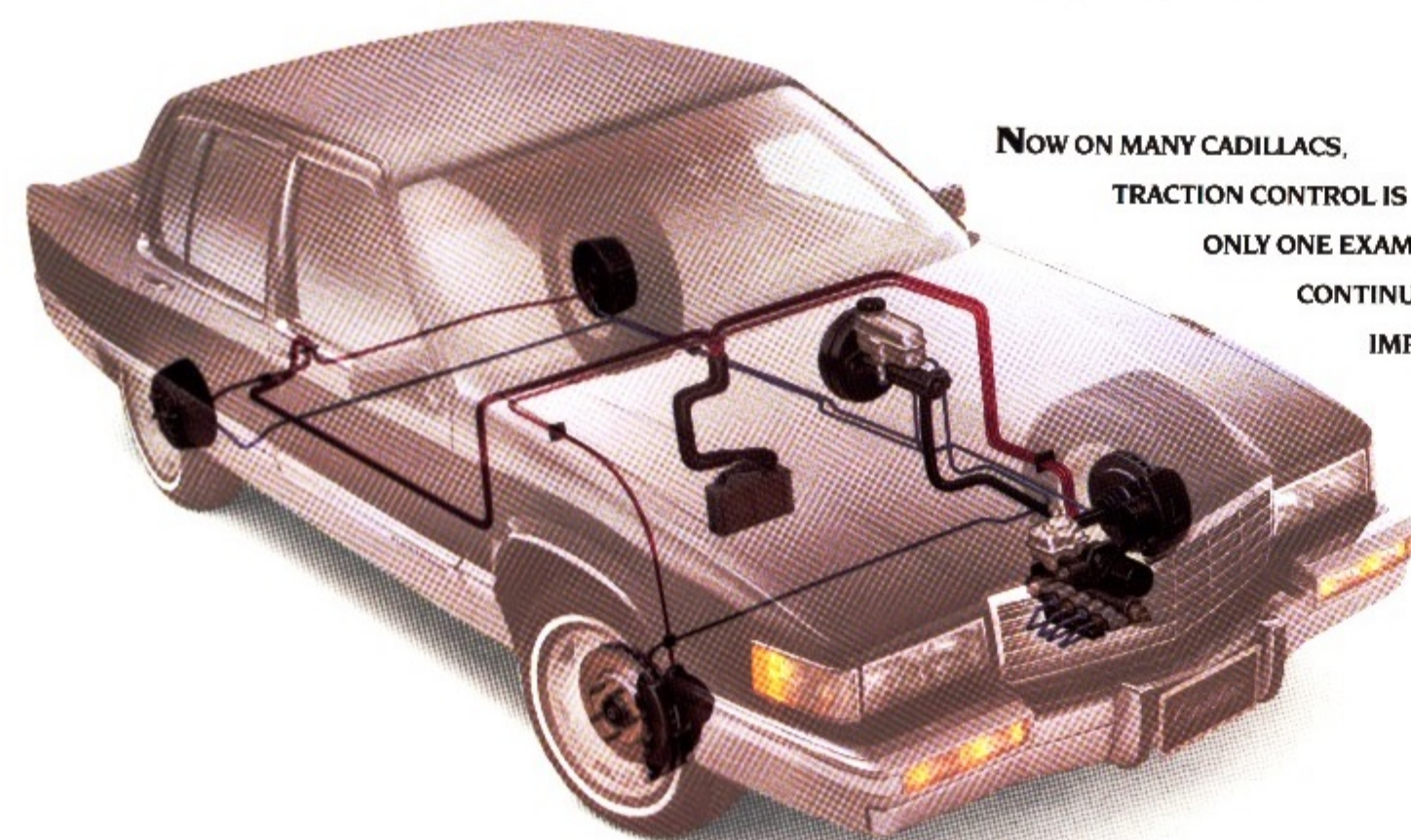

NOW ON MANY CADILLACS,  
TRACTION CONTROL IS  
ONLY ONE EXAMPLE OF  
CONTINUOUS PRODUCT  
IMPROVEMENT.

Control, unwanted wheel slip under 30 miles per hour in snow, on ice, or in the rain is minimized for maximum traction during acceleration virtually anywhere. (Allanté's Traction Control offers even more sophistication; please see page 44.)

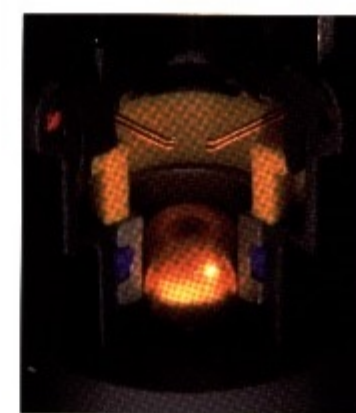

GOLD-PLATED AIR-BAG SENSOR.

## THE BALANCE OF POWER.

All Cadillacs are V8-powered, complemented by stan-

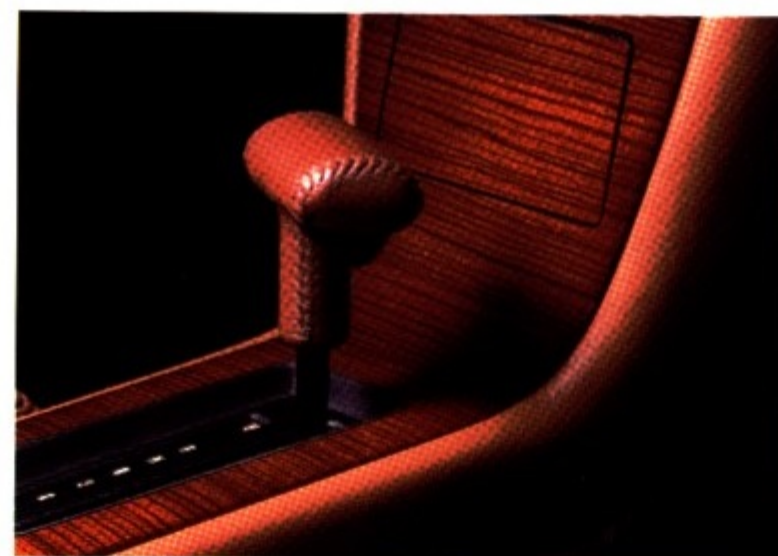

dard anti-lock brakes. Further, all front-drive Cadillacs have Speed-Sensitive Suspension standard or available to ease city driving yet afford impressive highway control.

## GOLD, PLATINUM AND MORE.

Gold plating protects vital air-bag sensor contacts from signal-stopping corrosion. Platinum is applied to every spark plug in front-drive Cadillacs, giving them 100,000-mile reliability.



DUAL-PLATINUM-TIPPED SPARK PLUG.

## A PREMIUM AMBIENCE.

Premium materials everywhere you look reflect our dedication to quality. Experience the understated elegance of new Zebrano wood in Eldorado and Seville. Polished American walnut wood abounds in Fleetwood and Touring Sedan. Glove-soft Nuance leather seating areas cradle you in Eldorado Touring Coupe and Seville STS. Ultra-soft leather seating areas surround you in Fleetwood Sixty Special and Touring Sedan. Rich Sierra grain leather seating areas are available for De Ville and Brougham.

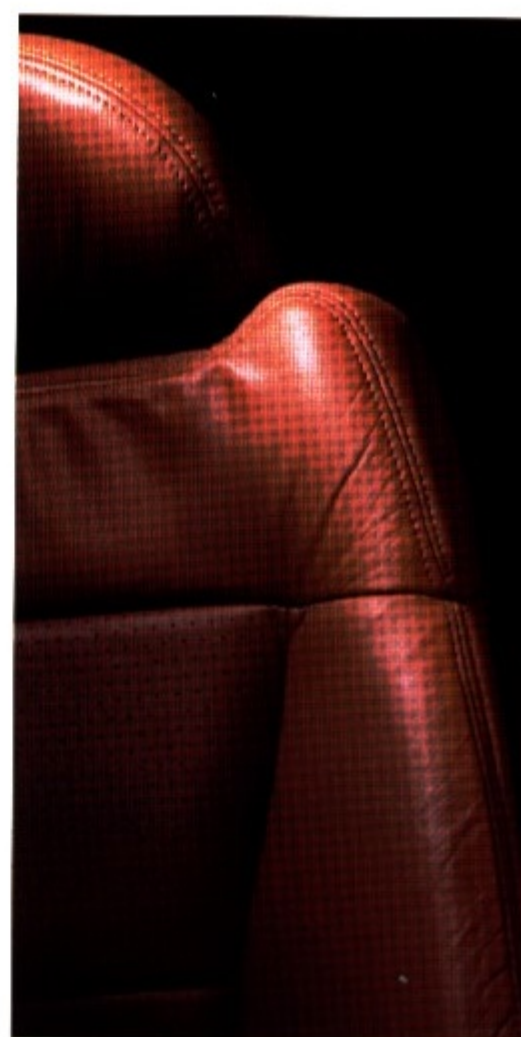

## PERFORMANCE TAKES SHAPE.

The precise integration of driver and automobile starts by combining technological advancements like a powerful 4.9 liter V8 that responds smoothly and gracefully with an electronically controlled automatic transmission that makes gear changes barely perceptible. Then, the Speed-Sensitive Suspension adapts to your driving

## SAFETY TAKES SHAPE.

We start with a rugged steel safety cage designed to remain intact during a collision. The cage is bolstered, front and rear, by crush zones designed to absorb impact energy and protect the passenger compartment.

## SUBSTANCE TAKES SHAPE.

Nowhere is the zeal for quality and substance more evident than in the new Seville. Born of a quest for breakthrough design. Fueled by a fierce dedication to quality. And driven by "simultaneous engineering" — the bringing together of engineering and design disciplines at once, so that the spontaneity and excitement remain high

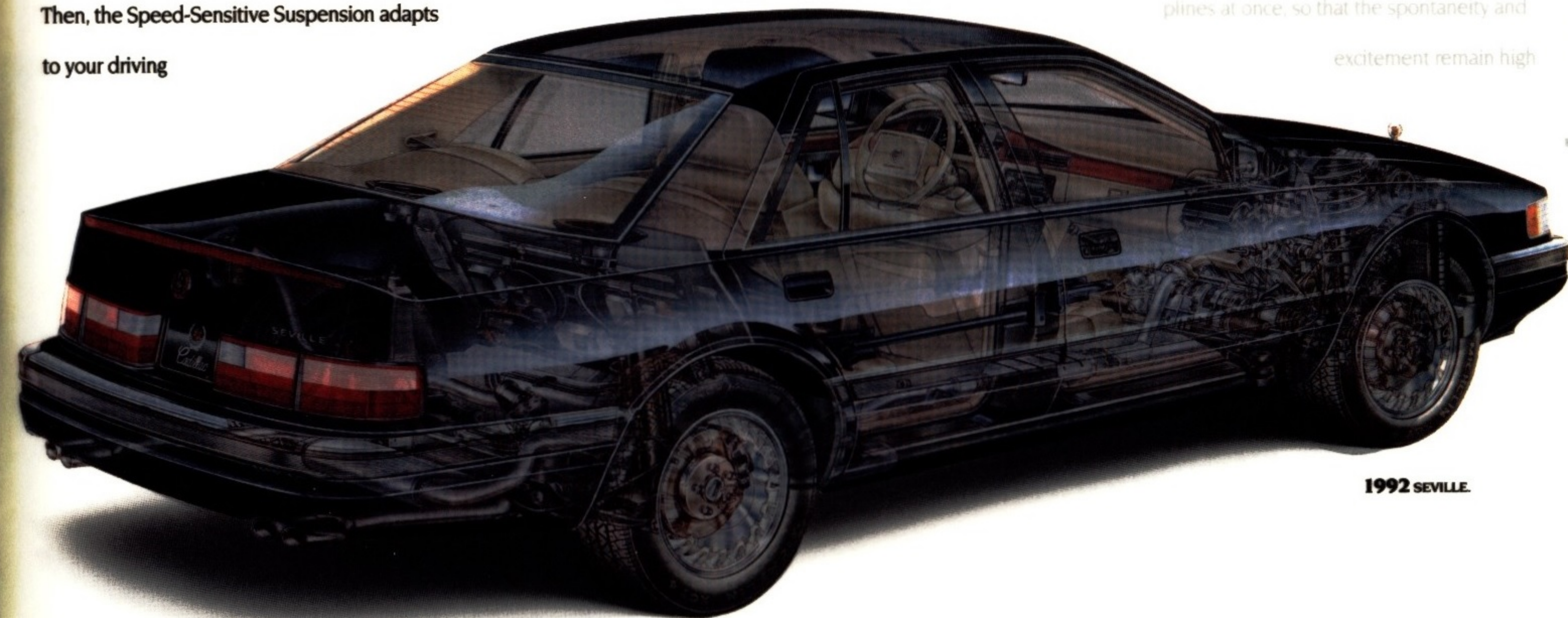

1992 SEVILLE.

speed for advanced ride and comfort control. Combine this with anti-lock brakes for added stopping assurance. Spirited handling and sophisticated refinement, within the contemporary envelope of the new Seville, is how substance takes shape, Cadillac Style.

Side-guard door beams not only further protect the passenger compartment from side intrusions, they also helped the 1992 Seville successfully complete dynamic side-impact testing even though this is not a government requirement for all car lines until 1997. There is also a driver's-side air bag, which is to be used with the safety belt system.



CADILLAC  
STYLE

# TECHNOLOGY

## AMERICA'S HIGHEST QUALITY HONOR.

For the first time, an automobile company has earned the U.S. Government's highest quality honor: the Malcolm Baldrige National Quality Award. That company is Cadillac. The honor has recognized an intense dedication to a new culture of quality. The legacy now drives Cadillac to even greater product refinement and continuous improvement. The 1992 Eldorado

Seville are cases in point. Both are complemented by standard anti-lock brakes. The 1992 Seville is also equipped with the advanced anti-lock braking technology.

1992 Seville bring your Cadillac to a controlled stop improves its traction during acceleration as well. Through Traction

Refer to individual car line sections for feature availability.

Control, unwanted wheel slip under 30 miles per hour in snow, on ice, or in the rain is minimized for maximum traction during acceleration virtually anywhere. (Allanté's Traction Control offers even more sophistication: please see page 47)



GOLD-PLATED AIR-BAG

## MORE.

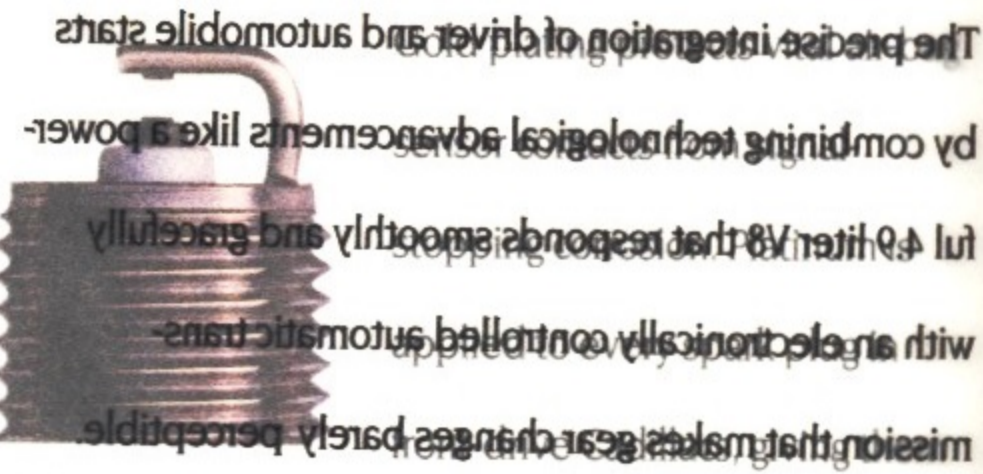

DUAL-PLATINUM, TIPPED SPARK PLUG.

## A PREMIUM AMBIENCE.

Premium materials everywhere you look reflect our dedication to quality. understated ele-

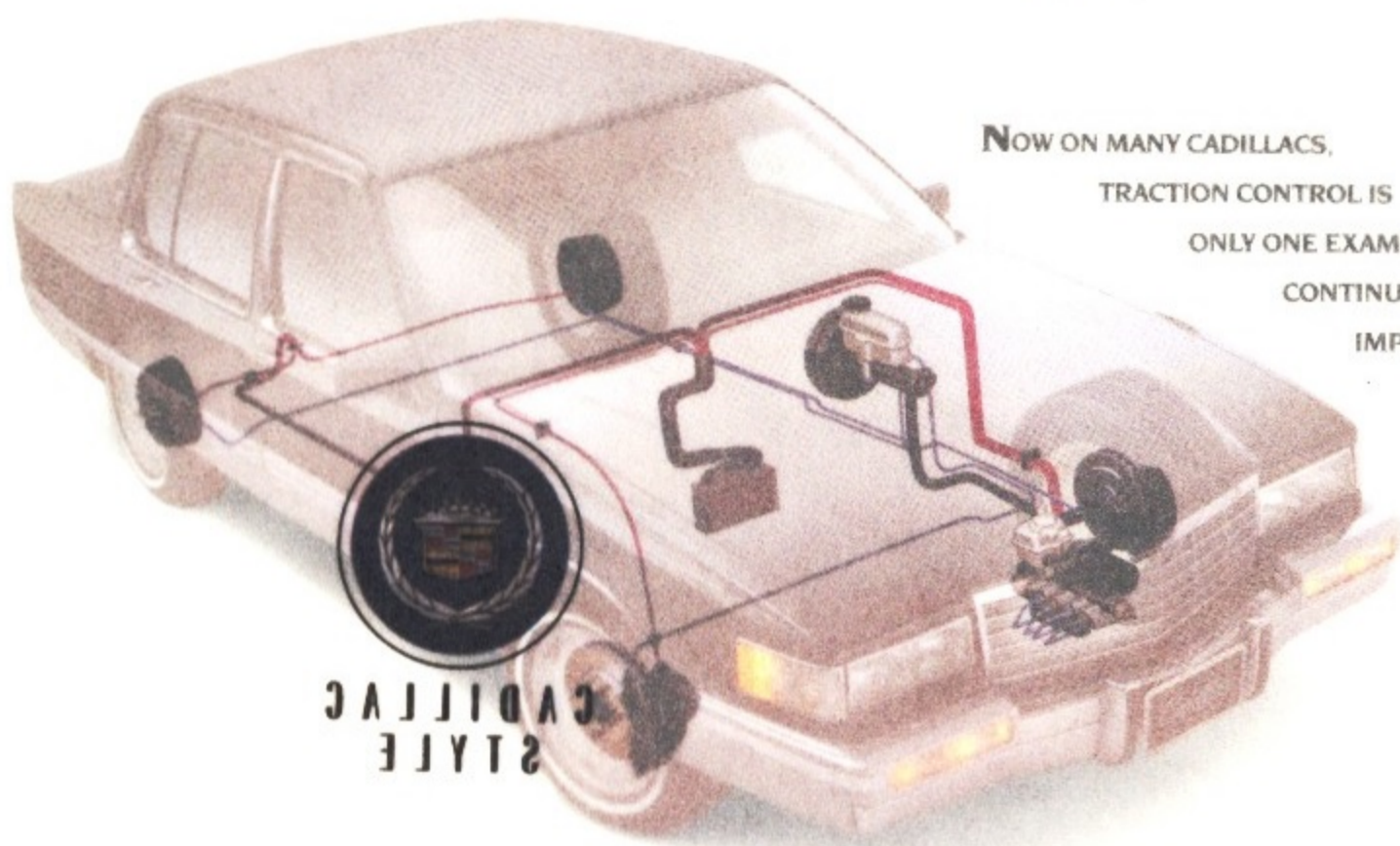
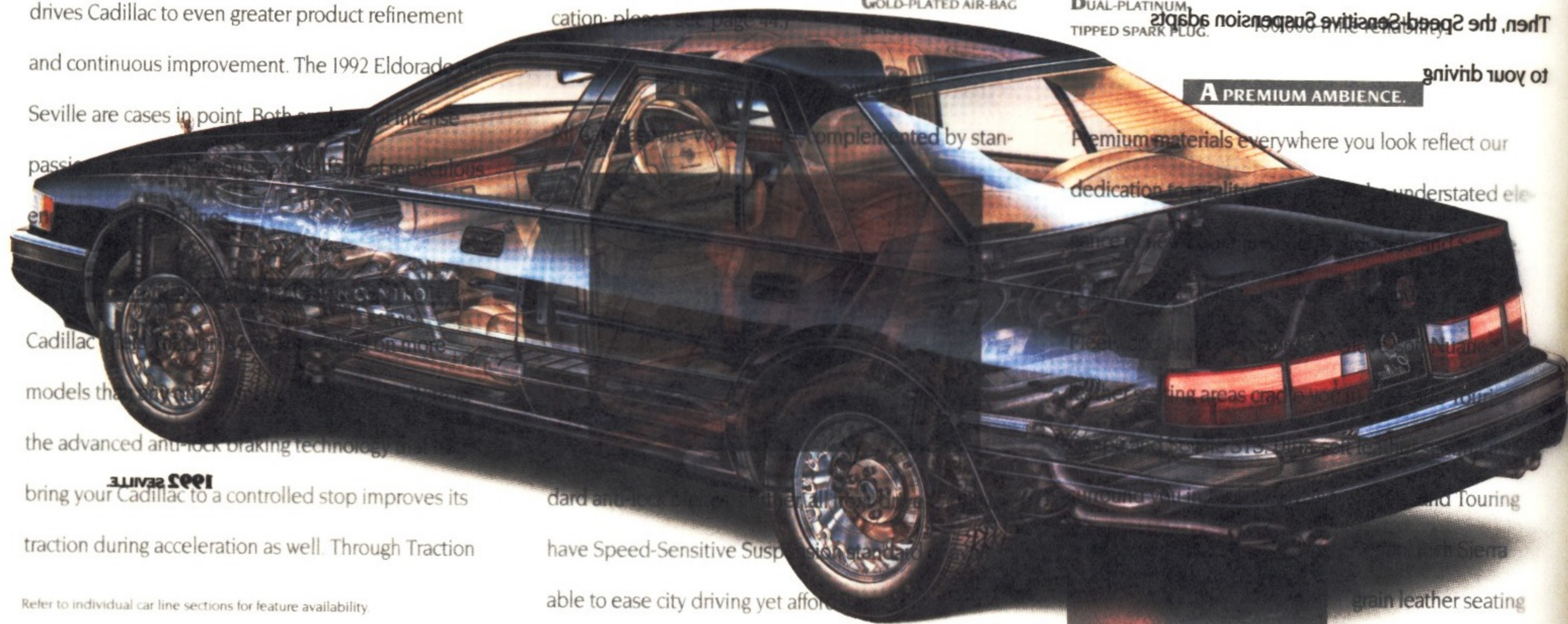

NOW ON MANY CADILLACS, TRACTION CONTROL IS ONLY ONE EXAMPLE OF CONTINUOUS PRODUCT IMPROVEMENT.

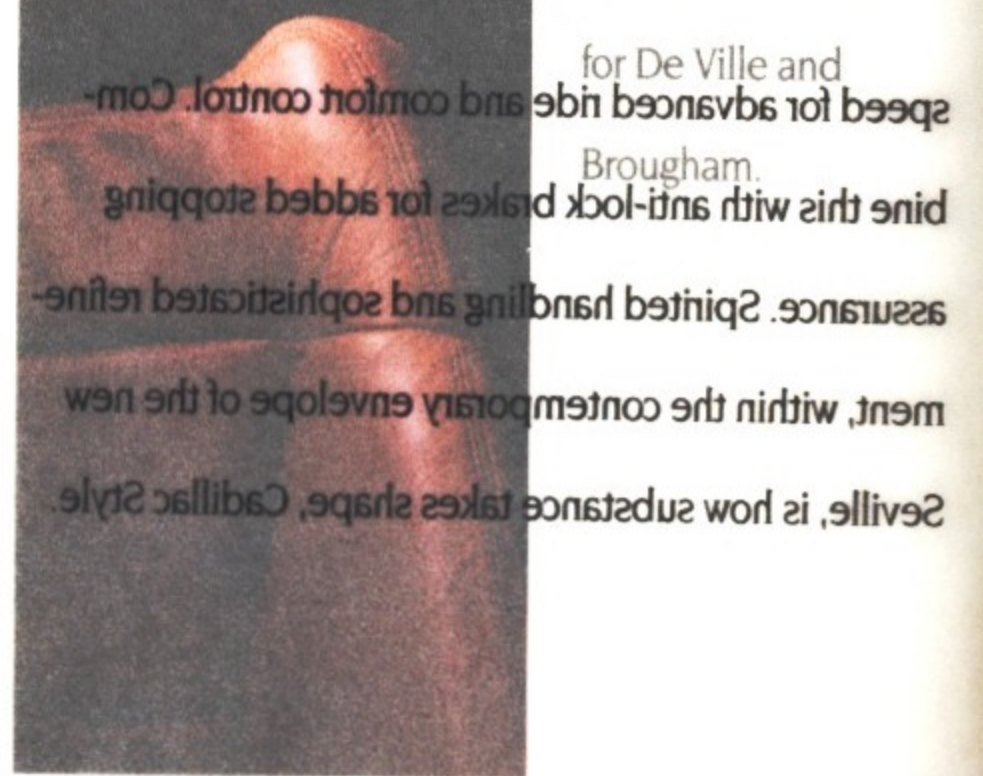

ment, within the contemporary envelope of the new Seville, is how substance takes shape, Cadillac style. Brougham. for De Ville and areas are available grain leather seating and touring have Speed-Sensitive Suspension. able to ease city driving yet afford highway control.

## SAFETY TAKES SHAPE.

We start with a rugged steel safety cage designed to remain intact during a collision. The cage is bolstered, front and rear, by crush zones designed to absorb impact energy and protect the passenger compartment.



Side-guard door beams not only further protect the passenger compartment from side intrusions, they also helped the 1992 Seville successfully complete dynamic side-impact testing even though this is not a government requirement for all car lines until 1997. There is also a driver's-side air bag, which is to be used with the safety belt system.

## SUBSTANCE TAKES SHAPE.

Nowhere is the zeal for quality and substance more evident than in the new Seville. Born of a quest for breakthrough design. Fueled by a fierce dedication to quality. And driven by "simultaneous engineering": the bringing together of engineering and design disciplines at once, so that the spontaneity and excitement remain high.



AMERICA'S HIGHEST QUALITY HONOR

For the first time, an automobile company has earned the U.S. Government's highest quality honor, the Malcolm Baldrige National Quality Award. That company is Cadillac. The honor has recognized an intense dedication to a new culture of quality. The legacy now drives Cadillac to even greater product refinement and continuous improvement. The 1992 Eldorado and Seville are cases in point. Both models have received the advanced award. The 1992 Seville brings you Cadillac's new controlled start, improves its traction during acceleration as well. Through Traction Control, you'll feel the car's control on the road. For more information, visit us at [www.cadillac.com](http://www.cadillac.com).



PERFORMANCE TAKES SHAPE

The precise integration of driver and automatic starts by combining technological advancements like a power front and rear, by crush zones designed to absorb impact energy and protect the passenger compartment. The 1992 Seville's 4.9 liter V8 first responds smoothly and gracefully with an electronically controlled automatic transmission that makes gear changes partly perceptible. Then, the speed-sensitive suspension adapts to your driving.

Then, the speed-sensitive suspension adapts to your driving.

A PREMIUM AMBIENCE

Everywhere you look reflect our commitment to quality. The 1992 Seville's interior is a masterpiece of design and engineering. The leather-upholstered interior is available in several colors. The 1992 Seville's interior is a masterpiece of design and engineering. The leather-upholstered interior is available in several colors. The 1992 Seville's interior is a masterpiece of design and engineering. The leather-upholstered interior is available in several colors.

Now on many Cadillacs

Side-guard door beams not only further protect the passenger compartment from side intrusions, they also helped the 1992 Seville successfully complete dynamic side-impact testing even though this is not a government requirement for all cars until 1997. There is also a driver's-side air bag, which is designed with the safety belt system.

SUBSTANCE TAKES SHAPE

Nowhere is the zeal for quality and substance more evident than in the new Seville. Born of a quest for breakthrough design. Fueled by a fierce dedication to quality. And driven by "simultaneous engineering": the bringing together of engineering and design disciplines at once, so that the spontaneity and excitement remain high.



# P E R F O R M A N C E



## THE SCIENCE OF LUXURY PERFORMANCE.

Cadillac, the leader in all-V8, all-ABS luxury automobiles, is now a leader in Traction Control.

Refined V8 power is the hallmark of every 1992 Cadillac. Power that is plentiful and responsive. Balanced power that lets you pass on two-lane roads and merge onto expressways with confidence. And in

Cadillacs with a 4.9-liter V8, the 200-horsepower response is balanced by impressive highway efficiency – an EPA-estimated 25 MPG highway.

The electronically controlled four-speed automatic transmission delivers barely detectable shifts. Its viscous converter clutch enhances smooth driveline feel.

Someday all luxury cars may offer Traction Control.

Today, however, Cadillac offers this advanced feature standard on more models than any other American automaker. The advanced technology that controls anti-lock brakes (ABS) improves your Cadillac's traction as well. Through Traction Control, unwanted wheel slip under 30 miles per hour (any speed on Allanté) is automatically minimized for maximum

traction during acceleration.

## SPEED-SENSITIVE SUSPENSION.

Standard or available on all front-drive Cadillacs. "Comfort," "normal," and "touring" modes complement your Cadillac's ride by automatically adapting suspension firmness to speed, acceleration or braking.

FULLY INDEPENDENT SUSPENSION (REAR DETAIL SHOWN) INCORPORATES SPEED-SENSITIVE ADJUSTMENT. IT MONITORS YOUR DRIVING AND RECALIBRATES ITSELF FOUR HUNDRED TIMES PER SECOND TO OFFER A BALANCE OF SUPERB IN-TOWN RIDE WITH STABLE HIGHWAY CONTROL.

Refer to individual car line sections for feature availability.

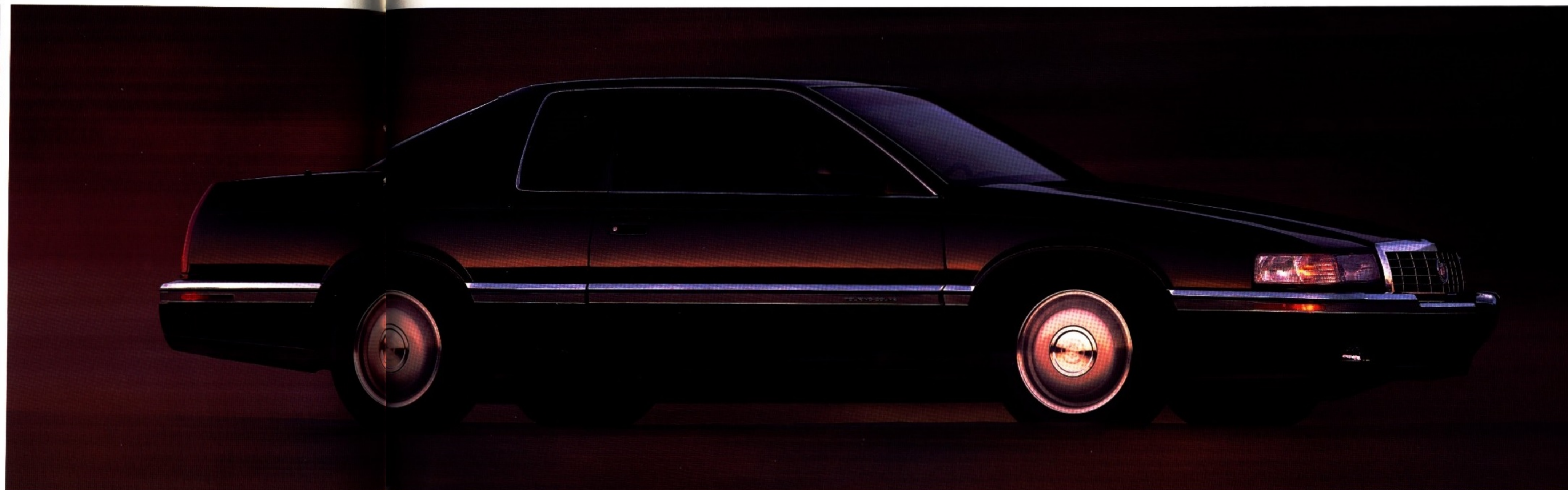
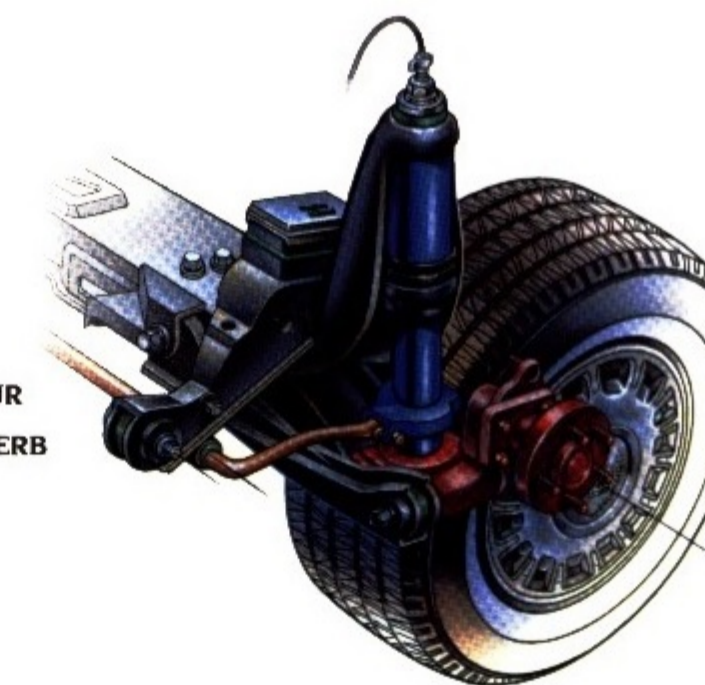

THE FOUR-SPEED AUTOMATIC TRANSMISSION IN 4.9-LITER V8-POWERED CADILLACS IS ELECTRONICALLY CONTROLLED TO DELIVER PRECISE, BARELY DETECTABLE SHIFTS, AND SMOOTH OPERATION AT HIGHWAY SPEEDS. CADILLAC'S EXCLUSIVE VISCOUS CONVERTER CLUTCH PROVIDES EXCELLENT HIGHWAY FUEL ECONOMY WHILE MAINTAINING DRIVE-LINE SMOOTHNESS.

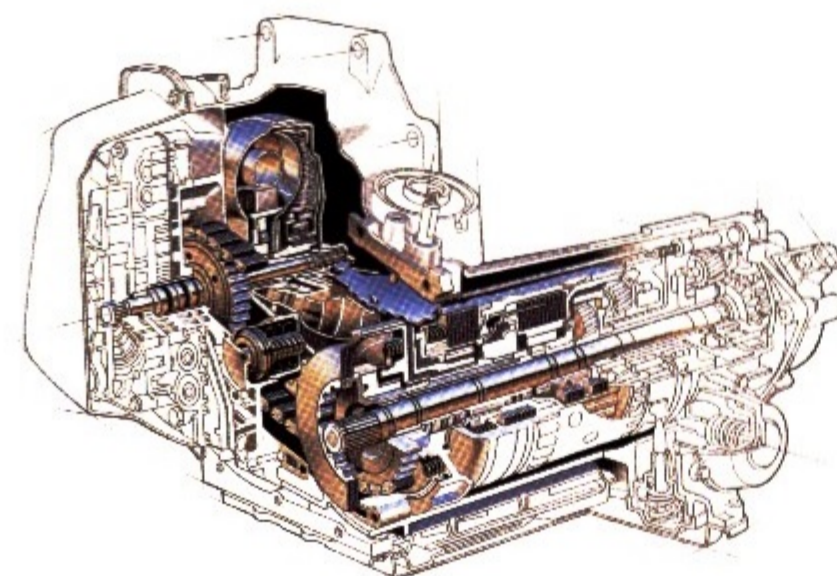

DUAL-PLATINUM-TIPPED SPARK PLUGS IN EVERY FRONT-DRIVE V8 OFFERED BY CADILLAC ARE DESIGNED FOR 100,000-MILE RELIABILITY.



ALLANTÉ, THE WORLD'S FIRST ROADSTER EQUIPPED WITH SOPHISTICATED TRACTION CONTROL STANDARD.

1992 ELDORADO TOURING COUPE.

# C O M F O R T



## THE SCIENCE OF SEATING COMFORT.

The sophistication that produces advanced power-trains also produces world-class comfort. From the moment you sit down, buckle in and turn the key, dozens of systems go to work to enhance your comfort.

For example, take seating. Seville and Eldorado's new front seating with Dual-Constant springs supports your body and follows the flow of car motion as it lets you experience a new level of ride comfort.

The available power lumbar supports move up and down as well as in and out for pinpoint accuracy and orthopedic support. And the seat controls are "metaphoric" (move the seat-shaped controls and the seat moves with them).



MOVE THESE "METAPHORIC" SEAT CONTROLS AND THE SEAT FOLLOWS TO HELP YOU ENJOY MAXIMUM COMFORT.



THE NEW DESIGN OF THE SEVILLE STS FRONT SEATS OFFERS DUAL-SPRING ACTION SUPPORT, PLUS POWER LUMBAR SUPPORT.

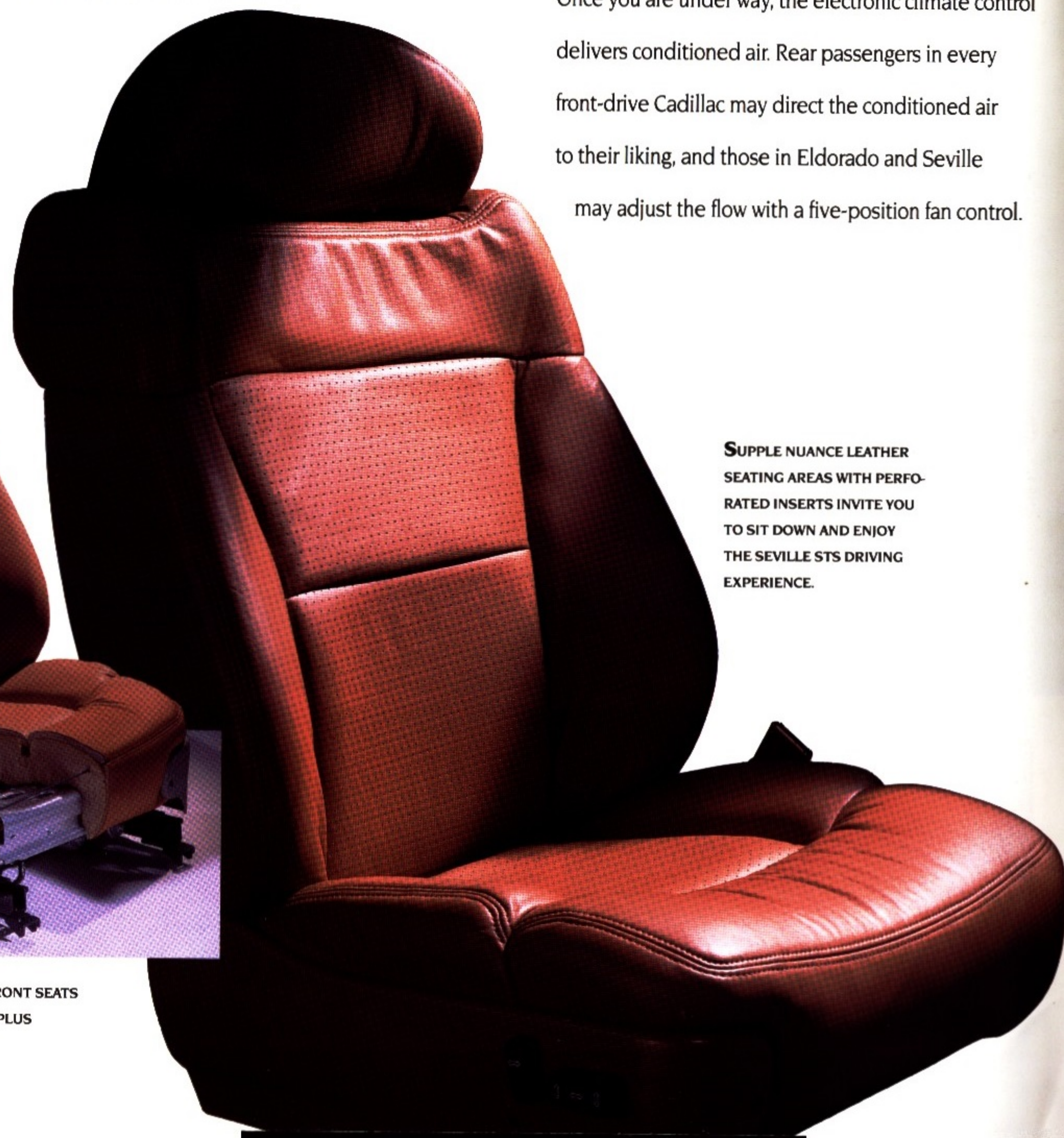

SUPPLE NUANCE LEATHER SEATING AREAS WITH PERFORATED INSERTS INVITE YOU TO SIT DOWN AND ENJOY THE SEVILLE STS DRIVING EXPERIENCE.

Further, every Fleetwood Sixty Special enfolds you in 22-way power front seats so advanced, they are patented. Bio-engineered with a leading university, the split-frame design permits adjustment to accommodate your individual physique.

## THE SCIENCE OF CLIMATE COMFORT.

Once you are under way, the electronic climate control delivers conditioned air. Rear passengers in every front-drive Cadillac may direct the conditioned air to their liking, and those in Eldorado and Seville may adjust the flow with a five-position fan control.

EZ-KOOL™ glass shields you from 57% of the sun's rays to keep you cooler, reduce glare and prolong interior beauty in De Ville and Fleetwood. A solar sensor knows when it's cloudy and sunny, and how high the

THE ELECTRONIC CLIMATE CONTROL'S SOLAR SENSOR MONITORS THE INTENSITY AND THE ANGLE OF INFRARED WAVES ENTERING THE PASSENGER COMPARTMENT. INTERIOR CLIMATE IS ADJUSTED ACCORDINGLY.



sun is in the sky. The result is automatic adjustments in climate control to keep you comfortable.

## THE SCIENCE OF QUIET.

You ride in a hushed atmosphere. The Seville and Eldorado have dual-perimeter door sealing that

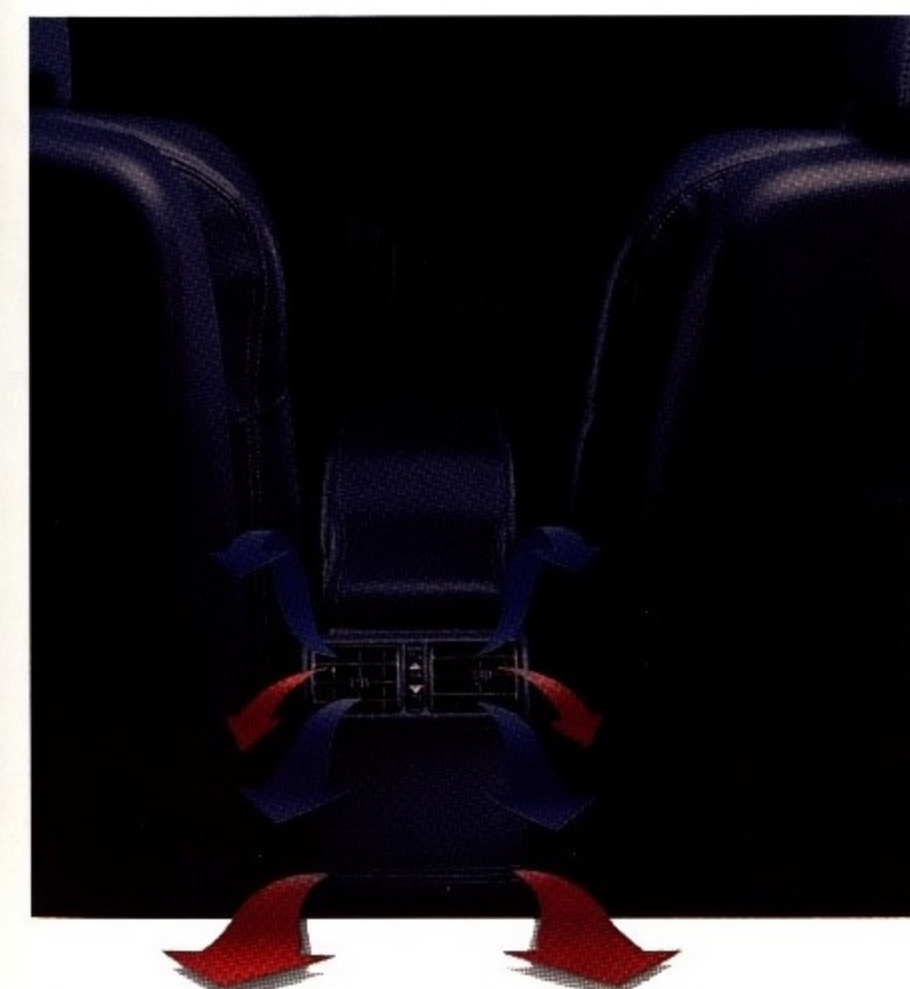

THE REAR-SEAT CLIMATE CONTROL VENT ON FLEETWOOD AND DE VILLE FEATURES MULTI-DIRECTIONAL AND AIR VOLUME CONTROLS.

muffles wind noise, and 5mm-thick side glass that effectively minimizes outside noise. The result of this extra attention to detail is an environment so friendly, you can enjoy subtle nuances of your favorite music from the available Delco/Bose Gold Series music system, one of the finest audio systems in any luxury car.

In 1992, this is how the substance of comfort takes shape, Cadillac Style.

Refer to individual car line sections for feature availability.



THE 5MM-THICK SIDE GLASS AND DUAL DOOR SEAL DESIGN ON SEVILLE AND ELDORADO FURTHER REDUCE OUTSIDE NOISE.

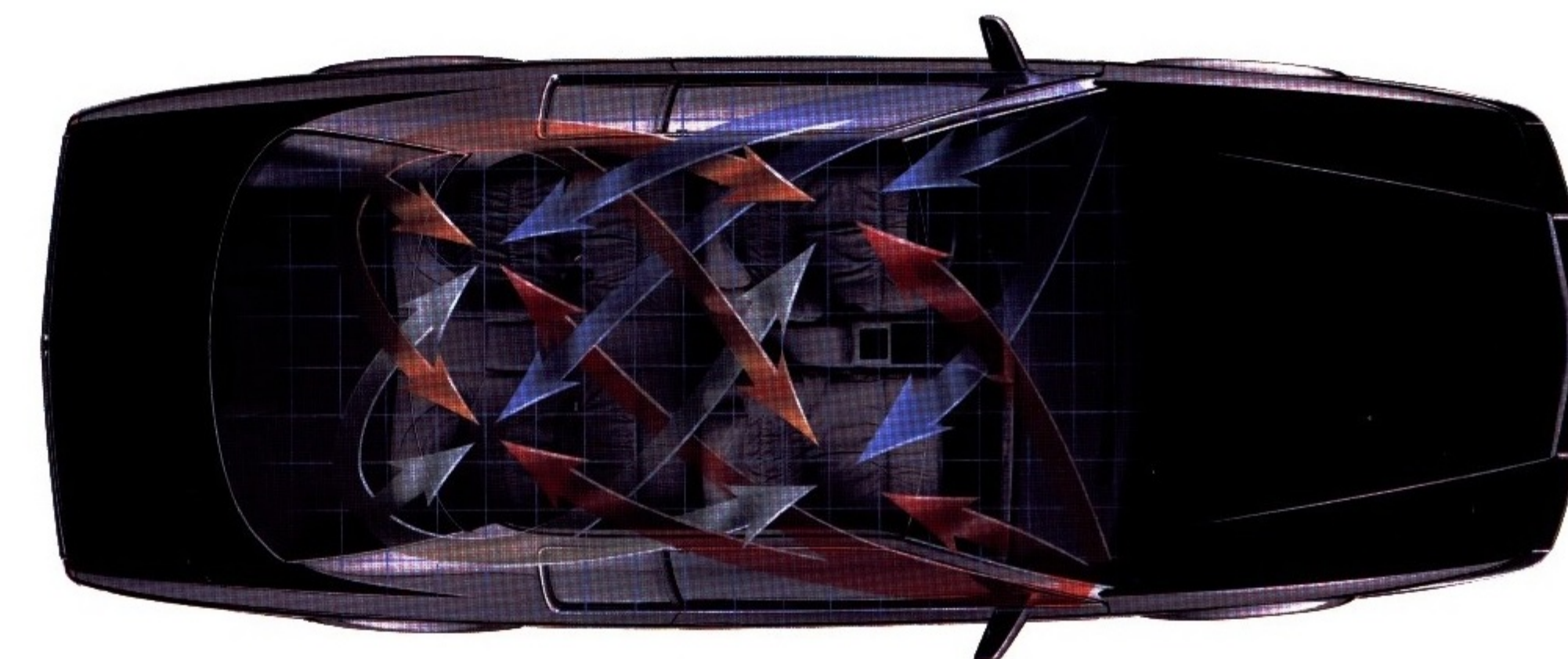

RENOWNED DELCO/BOSE SOUND SYSTEMS ARE STANDARD OR AVAILABLE ON ALL FRONT-DRIVE CADILLACS. PRECISE EQUALIZATION CREATES OPTIMUM SOUND FOR INDIVIDUAL CADILLAC INTERIORS.

# S A F E T Y

## THE SYSTEMS APPROACH TO ACCIDENT AVOIDANCE.

It is a philosophy we at Cadillac apply to automotive safety, and it begins with the fact that every Cadillac is designed with sophisticated active systems that work in concert with each other. They not only allow you to be a safer driver, they help you avoid an accident in the first place.



Traction Control helps minimize unwanted wheel slip under 30 miles per hour (any speed on Allanté) for maximum traction, affording you added confidence on ice, snow or gravel roads.

## PEACE-OF-MIND LEADERSHIP.

All front-drive Cadillacs have Speed-Sensitive Suspension standard or available. It automatically adjusts to your driving speed, acceleration or braking to keep your car at its optimal design attitude. Every Cadillac coupe and sedan features electronic level control.



THE ELECTROCHROMIC DIMMING OUTSIDE DRIVER REARVIEW MIRROR, STANDARD ON FLEETWOOD AND AVAILABLE ON DE VILLE, AUTOMATICALLY DARKENS TO REDUCE GLARE.

It "weighs" your luggage or how many people are riding with you and automatically adjusts the rear suspension accordingly. Electronic level control contributes to a smooth, level ride and even helps keep the headlights properly aligned to the road.



A HEATED WINDSHIELD, AVAILABLE ON FRONT-DRIVE CADILLAC COUPES AND SEDANS, UNLEASHES APPROXIMATELY 1,500 WATTS OF HEATING POWER TO CLEAR ICE OR FROST THREE TO FIVE TIMES FASTER THAN THE CONVENTIONAL DEFROSTER SYSTEM.

POWER TO PASS SAFELY, POWER TO MERGE CONFIDENTLY ON EXPRESSWAYS. TWO BENEFITS OF V8 POWER. (ALLANTÉ'S 200-HP V8 SHOWN.)

## WE EVEN IMPROVE YOUR NIGHT VISION.

At night, you drive behind tungsten-halogen lighting systems with multifaceted lenses that exceed federal safety standards, providing excellent foreground and lateral visibility.

Side cornering lights illuminate when you activate the turn signal, giving superior visibility at wider angles in the direction of the turn. They also alert other drivers of your intentions. Electrochromic inside rearview mirrors, standard or available on most Cadillacs, dim electronically to reduce glare. Electrically heated rear windows and, available on many Cadillacs, electrically heated windshields further enhance your visibility, especially during inclement weather. We've even made the gauge displays large and easy to read, day or night. Substance takes shape, Cadillac Style: the interrelated network of active safety systems working to protect you and your family.

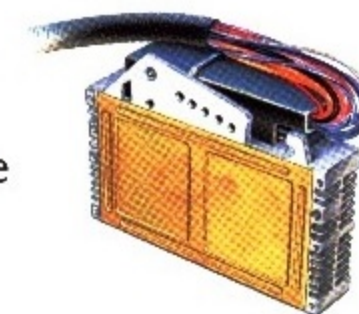

Refer to individual car line sections for feature availability.

ALL CADILLACS PROVIDE ANTI-LOCK BRAKE SYSTEMS (ABS) STANDARD. THE GREATEST BENEFIT: YOU CAN MAINTAIN STEERING CONTROL DURING PANIC BRAKING, ALLOWING YOU TO TAKE EVASIVE ACTION.

TRACTION CONTROL IS STANDARD ON MORE CADILLAC MODELS THAN FROM ANY OTHER AMERICAN AUTOMAKER.

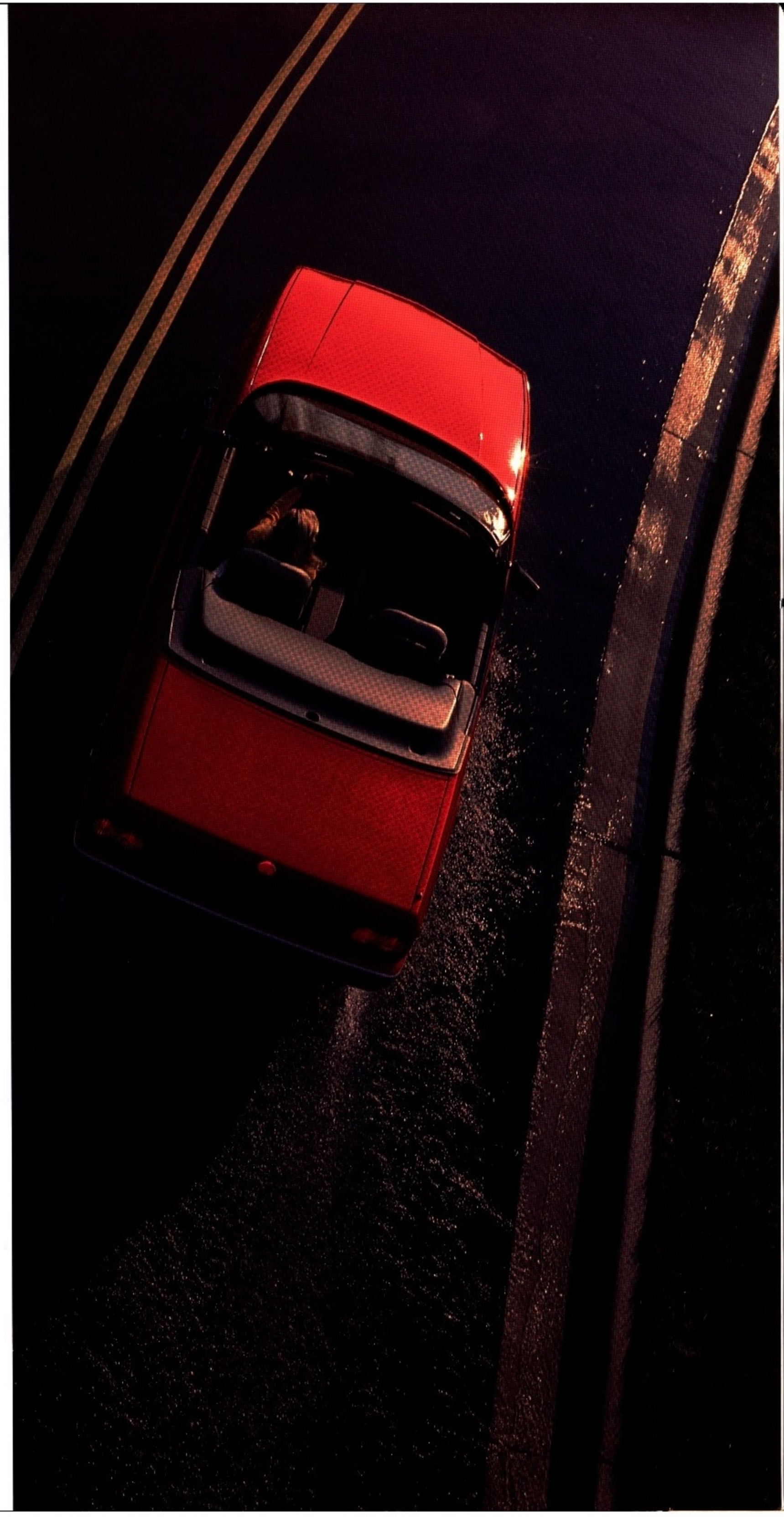

HALOGEN BULBS AND MULTIFACETED HEADLAMP LENSES EXCEED FEDERAL SAFETY STANDARDS FOR FOREGROUND AND LATERAL LIGHTING. CORNERING LAMPS INCREASE THE ANGLE OF ILLUMINATION DURING TURNS WITH THE TURN SIGNAL ACTIVATED.

## ALL-V8, ALL-ABS LEADERSHIP.

All Cadillacs are equipped with a standard V8 and ABS. Not all Mercedes-Benz, BMW, Audi, Jaguar, Lincoln, Lexus and Infiniti models are. A V8 means you have abundant reserves of power that let you pass easily on two-lane roads and merge with confidence on expressways. ABS gives you the ability to maintain maximum steering control during hard braking, taking the panic out of panic stops.

## TRACTION CONTROL LEADERSHIP.

Cadillac offers this advanced feature standard on more models than any other American automaker.



# S A F E T Y

## THE SYSTEMS APPROACH TO PASSENGER SAFETY.

The physics of building a safer automobile begins with the structural integrity inherent in every Cadillac.



Here, the sharp focus is on the network of passenger safety systems supported by accident-avoidance systems.

**AN ILLUMINATED ENTRY SYSTEM ACTIVATES INTERIOR LIGHTING FOR INCREASED PERSONAL SECURITY.**

By understanding the physics, forces are

carefully calculated and managed. Stopping loads are channeled away and dissipated to maximize occupant protection. This research is conducted at the largest automotive testing facility of its kind, where over 400 automobiles are barrier-crashed each year and their results analyzed.



Realistic instrumented Hybrid III anthropomorphic dummies, acknowledged as the finest in the world, record progress made in protecting real pas-

sengers. Although the U. S. Government requires airbag testing for only the 50th percentile, occupant models of this lifelike stand-in are tested at the 5th,



**EUROPEAN SAFETY STANDARDS REQUIRE THAT THE EDGE OF ANY INTERIOR SURFACE CONTACTED BY THIS 165MM TEST BALL (SIMULATING A HEAD FORM) IS CONTOURED TO HAVE A RADIUS OF 3.2MM MINIMUM.**



**SPECIAL "DY-THERM" COMPOSITION MATERIAL, IN COMBINATION WITH CAREFULLY DESIGNED BRACES, MAKE THE INSTRUMENT PANELS ON ELDORADOS AND SEVILLES MORE FORGIVING IN CASE OF IMPACT.**

**A UNIQUE "SANDWICH" OF ZEBRANO WOOD AND ALUMINUM IS DESIGNED TO CONTROL SPLINTERING IN CASE OF IMPACT.**



50th and 95th percentiles, going far beyond federal requirements—a clear commitment to your safety.

## SURROUNDED BY STEEL. PROTECTED BY AIR.

A steel safety cage surrounds the passenger compartment. Designed to be used with the safety belt system, the driver's-side Supplemental Inflatable Restraint System (air bag) has an inflation rate engineered for your protection.

## THREE POINTS WORTH REMEMBERING.

Three-point lap and shoulder belts are standard at every Cadillac window-seat position. Safety belts in all front-drive coupes and sedans permit precise adjustment around child safety seats.

## DESIGNED FOR WORLD SAFETY STANDARDS.

The new Seville and Eldorado meet or exceed all pertaining American, European and Japanese safety standards. This emphasis on safety is part of the largest ongoing safety research program in the world.

**ENERGY-ABSORBING "CRUSH ZONES"—FRONT AND REAR—REDUCE COLLISION ENERGY BEFORE IT REACHES THE PASSENGER COMPARTMENT.**

**ONE OF SEVERAL STRATEGICALLY PLACED AIR-BAG SENSORS THAT TRIGGER INFLATION ABOVE DETERMINED IMPACT SPEEDS. GOLD-PLATED CONTACTS EXTEND RELIABILITY AND ELECTRICAL CONDUCTIVITY.**

**A RUGGED SAFETY CAGE WITH STRONG STEEL SECTIONS ALONG THE ROOF, PILLARS AND ROCKER PANELS IS DESIGNED TO PROTECT YOU AND YOUR FAMILY.**

**CADILLAC WAS AMONG THE FIRST TO AFFORD YOU THE ADDED PROTECTION OF SIDE-GUARD DOOR BEAMS, PART OF A VAULT-LIKE DOOR ASSEMBLY, REINFORCING THE SAFETY CAGE.**

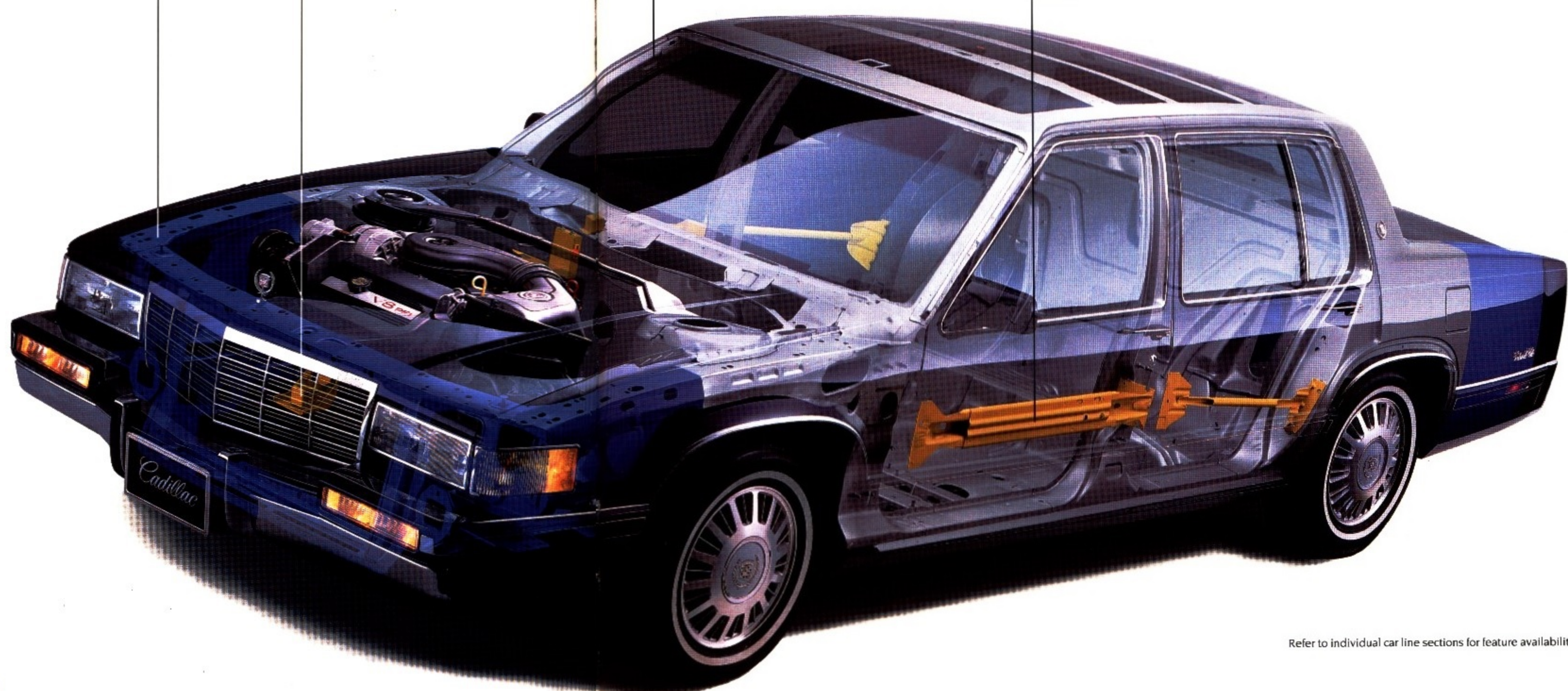

Refer to individual car line sections for feature availability.

## OCCUPANT PROTECTION.

Automatic safety belt system for driver and right front passenger (Brougham) or Supplemental Inflatable Restraint, driver only, with manual lap/shoulder safety belts for the driver and right front passenger (Allanté, Fleetwood, DeVille, Eldorado and Seville) both including visual and audible warning system

Manual lap/shoulder safety belts, outboard rear-seat positions

Manual lap safety belts, center front/rear seat positions, where applicable

Energy-absorbing steering column

Energy-absorbing instrument panel

Energy-absorbing seatback tops, front

Interlocking door latches

Laminated windshield glass with urethane bonding

Side-guard door beams

Passenger-guard inside door lock handles

Inertia-locking, folding front seat-backs, two-door models

Safety armrests

Head restraints, driver and right front passenger (adjustable or integral) rear seats (Seville, Eldorado)

Breakaway inside rearview mirror

Security door lock and door retention components

Power door locks with automatic locking features (DeVille, Fleetwood, Brougham, Eldorado Touring Coupe, Seville STS)

Tempered safety glass, side windows; also rear windows

Front and rear crush zones

Child security locks (Seville, Seville STS, Sedan de Ville,

Touring Sedan, Fleetwood Sedan, Fleetwood Sixty Special)

Pressure-lock radiator cap

Dual sun visors

## ACCIDENT AVOIDANCE.

Side marker lamps and reflectors

Parking lamps that illuminate with headlamps

Four-way hazard warning flashers

Back-up lamps

Center high-mounted stop lamp

Directional signal control with lane-change feature (turn signal lamp)

Windshield defroster, washer and multi-speed wipers

Inside manual day/night rearview mirror

Outside left and right rearview mirrors

Brake system with dual master cylinder and warning light

Starter safety switch

Dual-action hood latch

Low-glare finish on inside windshield moldings, wiper arms and blades, metallic steering-wheel surfaces

Illuminated heater and defroster controls

Illuminated windshield wiper and washer controls (Allanté and Brougham)

Tires with built-in tread wear indicators

Safety road wheel rims

Pressure-relief fuel cap (pressure-relief fuel system on Allanté)

Anti-lock brakes

Audible brake lining wear indicators, disc brakes

Brake/transmission shift interlock (Seville, Eldorado, Fleetwood, DeVille)



**THE SUBSTANCE TAKES SHAPE.**

When individual Cadillacs are crafted, the substance of Cadillac takes shape. Where you see the reflection of your own high standards.

**CONTINUOUS IMPROVEMENT.**

Eldorados, Sevilles and Allantés all benefit from the Assembly Line Effectiveness Center (ALEC). Months

One computer manages both engine and transmission.

The results are a smooth application of power.

Other sophisticated computers manage the electronic climate control, many power-operated comforts, and servicing, including self-diagnosis.



V8 ENGINES UNDERGO TESTS FROM 120° TO -35°F.

**THE DIGITAL SOUND OF CADILLAC QUIET.**

The hushed ambience of Cadillac interiors results from some of the world's most advanced audio research tools. This lifelike binaural head, for instance, connects to the most current digital recording technology. By employing sophisticated computers to isolate unwanted sounds, engineers quantify them on a full-color "sound-print," to see what they hear. Then it's reengineer, retest and reevaluate, until the team agrees that it has met its objective.

**MAKING YOUR CADILLAC LOOK NEW THROUGH 1998 AND BEYOND.**

Cadillac takes a systems approach to corrosion control to help keep your Cadillac looking new for years. The system, in three interlocking parts, is: design,

ADVANCED ACOUSTIC RESEARCH, INCLUDING ON-BOARD BINAURAL DIGITAL RECORDING, HELPS ISOLATE AND ELIMINATE UNWANTED NOISE.

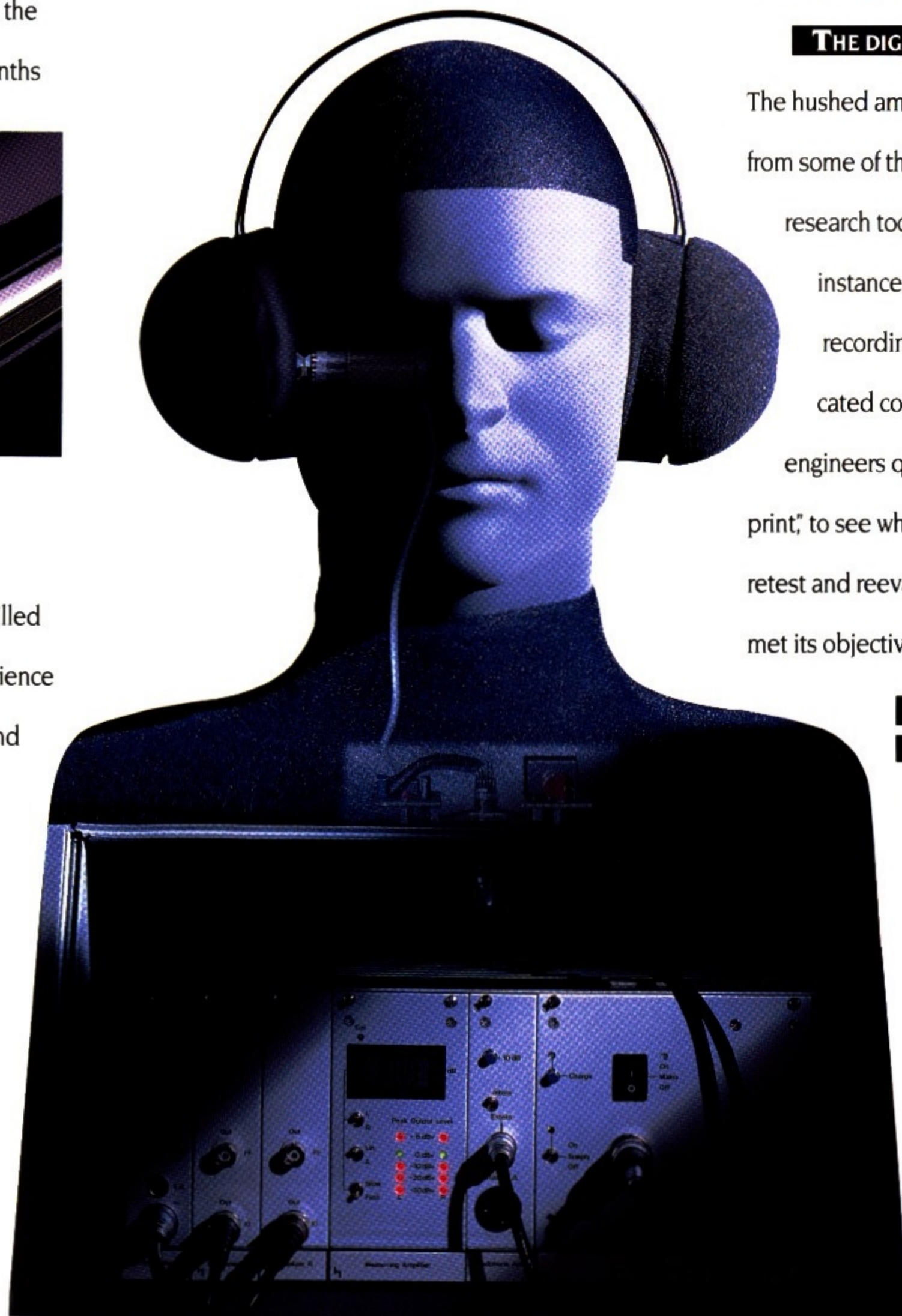

AN ALEC TEAM DEVELOPED A WAY TO INSTALL THE MOLDING ON THE 1992 SEVILLE FOR CONSISTENTLY HIGH QUALITY.

before a vehicle is scheduled for production, skilled assemblers contribute hundreds of years' experience to a micro assembly line, alongside designers and engineers. There, each assembly step is carefully evaluated before actual production.

**COMPUTER-MANAGED PRECISION.**

Cadillacs utilize advanced on-board computers.



CADILLAC DIAGNOSTICS MADE SIMPLE.



STEEL STRUCTURAL MEMBERS AND BODY PANELS (EXCEPT ROOF) OF FRONT-DRIVE CADILLACS HAVE TWO-SIDE GALVANIZED PROTECTION AGAINST CORROSION. PRECISION MULTI-STEP SEALING, PRIMING AND PAINTING ENTERS, COATS AND SEALS ALL CREVICES. CADILLACS ARE EVEN DUSTED WITH OSTRICH FEATHERS BEFORE THE CRITICAL PAINTING PHASE TO HELP ASSURE THE MOST FLAWLESS APPLICATION OF ALL COATINGS.

processing and materials. Engineers design the vehicle for paint access, and eliminate or reduce crevices that can trap moisture to stop corrosion before it can start. Engineers utilize both statistical process control techniques for repeatable quality, and state-of-the-art paint spray equipment and robotics to assure potential corrosion-prone areas are covered and sealed. Materials are specially chosen for corrosion resistance, and body steel of front-drive Cadillacs is

treated with pure zinc coatings—inside and out—before manufacture, then coated with primers, paint and clearcoat (on the exterior) after. Laboratory, road and field tests verify the system—design, processing and materials. The results are tangible and backed by



PERCEPTION<sup>SM</sup> LASER BEAMS PROBE AND PEER INTO CADILLAC BODIES AT MORE THAN 600 POINTS, VERIFYING ADJACENT BODY FITS THAT MEET YOUR EXACTING STANDARDS.

Refer to individual car line sections for feature availability. \*See your dealer for terms of these limited warranties.

6-year/100,000-mile rust-through corrosion protection (7-year/100,000-mile on Allanté).\*

MULTI-STEP LUSTROUS FINISH BEGINS WITH A THOROUGH BODY WASH ON BOTH SIDES OF THE GALVANIZED STEEL. A PHOSPHORIC COAT, RINSE AND ELECTRONIC DEPOSITION PREPARE THE BODY FOR PRIMERS, COLOR COATS AND A FINAL CLEAR-COAT TOP COAT.



# OWNERSHIP

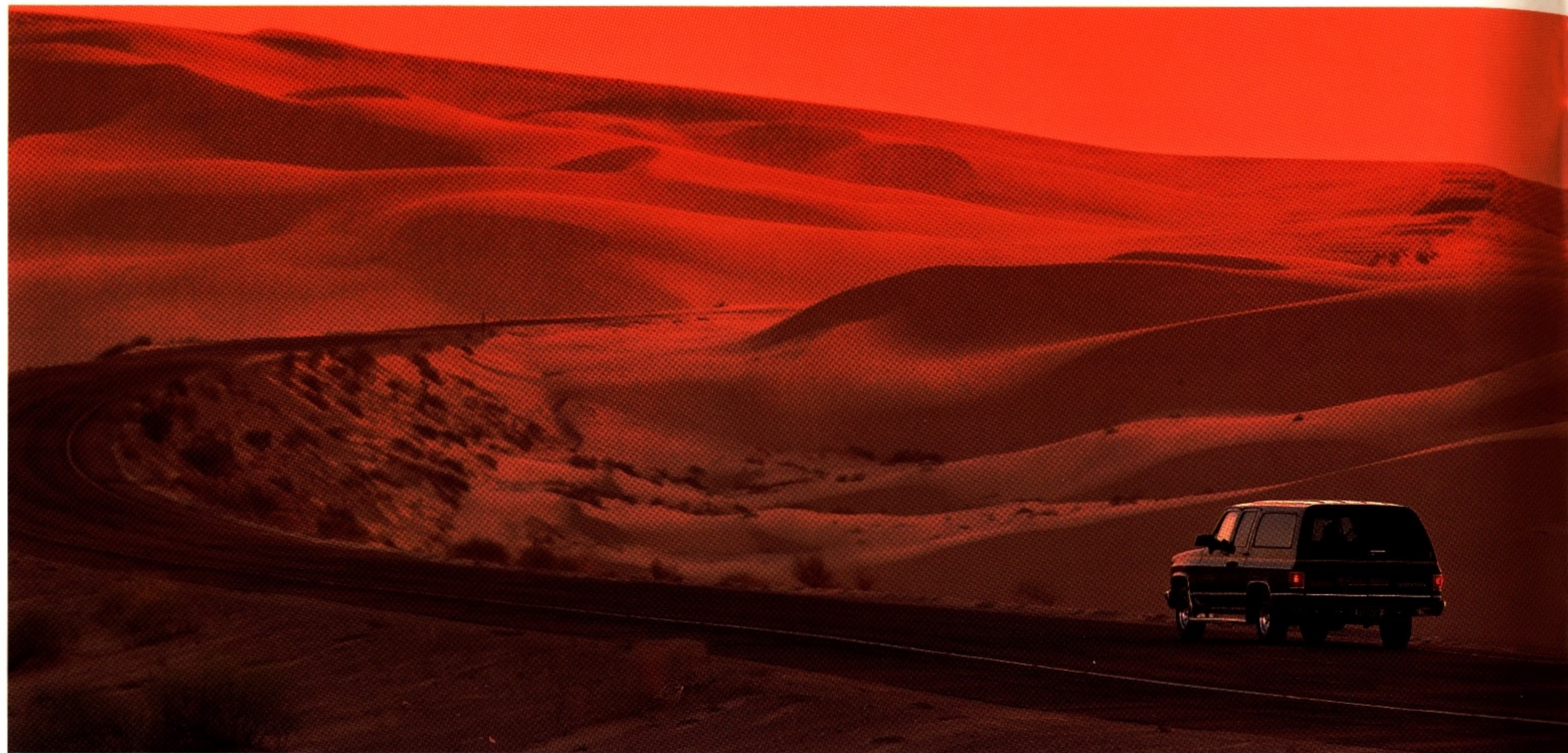

CADILLAC ROADSIDE SERVICE<sup>®</sup>—FROM MORE PARTICIPATING DEALERS THAN ANY OTHER ROADSIDE PROGRAM. SPECIAL VEHICLE CARRIES GENUINE GM PARTS.

## ONE OWNER AT A TIME.

As the owner of a new Cadillac, you are afforded considerable ownership privileges. Such as new enhancements to the finest roadside service program of its kind. The luxury of over 1,600 servicing dealers. The excellence of Cadillac's no-deductible warranty. In all, a most impressive array of owner privileges. One more reason why Cadillac excels in repeat ownership, ranking number one among leading luxury cars.\*

## CADILLAC ROADSIDE SERVICE.

The finest roadside service program has more partici-

pating dealers providing on-the-spot assistance than any other program of its kind.

You can call toll-free 1-800-882-1112 and converse with factory-trained service advisors 24 hours a day, 365 days a year, no matter what model-year Cadillac you own. With an advanced communications network, a Roadside Service advisor can pinpoint your nearest participating dealer simply by inputting the public phone number from which you call.

The advisor can then help remedy your situation right over the phone. And, if necessary, a highly

trained service technician will be dispatched to provide on-the-spot service when you need it the most—nights, weekends and holidays.

## NEW: ADDED CONVENIENCE BENEFITS.

Now Cadillac Roadside Service has been significantly enhanced for 1992. During the first 12 months/12,000 miles, Cadillac Roadside Service provides trip-interruption protection and free emergency road service.

You are reimbursed for incidental expenses necessitated by a covered repair while traveling—hotel, food and telephone.

And you receive free lock-out assistance, jump starts, flat-tire change, fuel delivery and towing service.

For four years or 50,000 miles, Cadillac will provide you with a computerized travel log and a detailed U.S.-Canada atlas.

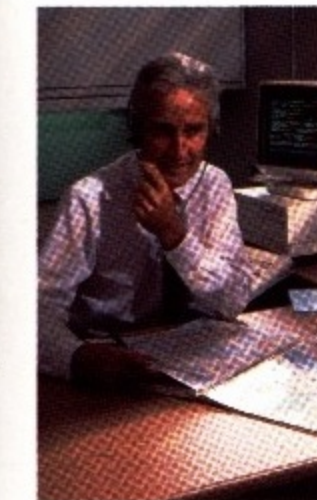

CALL THE CADILLAC CONSUMER RELATIONS CENTER AT 1-800-458-8006 ANY HOUR, ANY DAY. A FACTORY-TRAINED ADVISOR WILL ANSWER.

## WE LISTEN 24 HOURS A DAY.

Cadillac's Consumer Relations Center provides 24-hour-a-day customer service to respond to your questions and inquiries, 365 days a year. Call 1-800-458-8006.

Allanté owners may call 1-800-ALLANTÉ.

## NO-DEDUCTIBLE BUMPER-TO-BUMPER WARRANTIES.

Warranty protection that's among the finest of any luxury automobile, foreign or domestic. The Cadillac Gold Key Bumper to Bumper Warranty covers every component in every Cadillac for 4 years/50,000 miles, with no deductibles.<sup>1</sup>

The Allanté Assurance Plan extends powertrain and major assembly component protection to 7 years/100,000 miles.<sup>2</sup>

## MORE THAN 1,600 DEALERS NATIONWIDE.

Cadillac's dealers, nationwide, are committed to making Cadillac owners the most cared-for in the world. With up-to-date facilities and highly skilled service technicians available to give you the kind of service a Cadillac owner expects.

## A PERSONAL INTRODUCTION.

As part of Cadillac's Gold Key Delivery System, your sales representative personally reviews your new Cadillac with you, makes sure the fuel tank is filled, introduces you to key dealer people, and more.



THE CADILLAC GOLD KEY DELIVERY SYSTEM INCLUDES A PERSONAL INTRODUCTION TO YOUR NEW CAR AND KEY DEALER PERSONNEL.



CADILLAC ROADSIDE SERVICE: ROUND-THE-CLOCK PEACE OF MIND.

<sup>1</sup>According to an R. L. Polk & Co. study of initial retail purchasers of leading 1990 luxury cars.

<sup>2</sup>Covers every component except tires, which are covered by their manufacturer; adjustments, normal maintenance items; and battery, which is covered by its own 4-year/50,000-mile prorated warranty. See your dealer for terms of this limited warranty.

<sup>3</sup>Unique Allanté Assurance Plan. See your dealer for terms of this limited warranty.

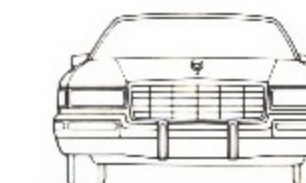

Gold Key BUMPER TO BUMPER WARRANTY



THE CADILLAC GOLD KEY BUMPER TO BUMPER WARRANTY COVERS EVERY COMPONENT IN EVERY CADILLAC FOR 4 YEARS/50,000 MILES WITH NO DEDUCTIBLE.<sup>1</sup>



THIS GRILLE MEDALLION, IN HONOR OF CADILLAC'S PREEMINENT POSITION IN OWNER LOYALTY, SIGNIFIES THE NUMBER OF CADILLACS PURCHASED BY AN OWNER—COMPLIMENTS OF YOUR PARTICIPATING CADILLAC DEALER.

Substance Takes Shape, Cadillac Style.

The challenge was to design and engineer a sophisticated vehicle that could offer the spaciousness and comfort of a five-place luxury automobile with the road performance of a touring sedan.

The result is the 1992 Cadillac Seville, endowed with proven technology that bolsters the automobile's capabilities. Including an electronically controlled V8 powertrain, Speed-Sensitive Suspension and anti-lock brakes. Balanced by a refined interior of premium materials in which thoughtfully placed controls are within comfortable reach. And where there's room for everything except compromise.



CADILLAC  
STYLE



S E V I L L E



## Substance Takes Shape, Cadillac Style.

The challenge was to design and engineer a sophisticated vehicle that could offer the spaciousness and comfort of a five-place luxury automobile with the road performance of a touring sedan.

The result is the 1992 Cadillac Seville, endowed with proven technology that bolsters the automobile's capabilities. Including an electronically controlled V8 powertrain, Speed-Sensitive Suspension and anti-lock brakes. Balanced by a refined interior of premium materials in which thoughtfully placed controls are within comfortable reach. And where there's room for everything except compromise.



The 1992 Cadillac Seville is the result of over five years of research and development, guided by a dramatically new culture of simultaneous engineering. Designers, engineers, and specialists from various disciplines were brought together to apply advanced new designs and technologies. Guiding their work was a single focus: the voice of the customer.



SEVILLE'S NEW, AERODYNAMIC DESIGN CREATES A LOW 0.33 COEFFICIENT OF DRAG FOR REDUCED WIND NOISE.



## Openness And Order.

Seville's all-new interior creates an environment of comfort and order. Seating is contoured to you and your passengers. Available Nuance leather seating areas are garment-soft to the touch. And Dual-Constant springs provide cushioned support while allowing driver and passenger to move with ride motions.

The linear grain of the Zebrano wood reinforces the openness of the interior. Extraneous noise is minimized via double-sealed doors and sleek aerodynamics. Rear-compartment ventilation controls make the aft of the interior as comfortable as the fore. And rear-seat legroom is generous.

SOFT, ELEGANT ILLUMINATION OF WINDOW CONTROLS AFFORDS YOU EASIER ACCESS.



The new Seville STS offers you a more spirited balance of responsive performance and sophisticated refinement. By virtue of a powerful V8, electronically controlled transmission and

performance final drive ratio. Anti-lock brakes. A specially tuned adaptive suspension. And by surrounding you with an interior replete with fine wood and aromatic leather seating areas.



# S E V I L L E S T S



SEVILLE STS SHOWN IN CARMINE RED.

S  
E  
V  
I  
L  
L  
E  

---

21

## e Your Senses.

The interior of the Seville STS appeals to the intellect as well as the senses.

Orthopedically designed front bucket seats feature a unique power lumbar support, which moves in the seat to help you pinpoint the exact height and depth you find most comfortable. Seating areas are fitted with aromatic Nuance leather, specially chosen for its garment softness, then perforated for enhanced breathability.

The linear grain of Zebrano wood accents the cluttered instrument panel. And rear-seat passengers enjoy not only remarkable legroom, but also a four-compartment climate control vent with multi-directional and multi-speed air-volume controls.



THE FULL CONSOLE ON THE SEVILLE STS IS ACCENTED WITH ZEBRANO WOOD. THE LEATHER-SEWN SHIFTER IS OFFSET AT A NATURAL 20-DEGREE ANGLE—FURTHER EVIDENCE OF THE SEVILLE STS'S TOTAL DRIVER ORIENTATION.



SEVILLE STS INTERIOR SHOWN WITH STANDARD NUANCE LEATHER SEATING AREAS IN BEECHWOOD.



## You've Never Driven A Seville Like This Before.

The new Cadillac Seville performs with the same level of power, refinement and agility that its striking profile suggests.

Inside, every placement, every contour, every control has been human-engineered to make you more comfortable driving the Seville the way it was intended to be driven.

The teardrop slope of the instrument panel flows with the horizon, orienting you to the road. Ergonomically clustered controls grant instant access. Available analog gauges inform at a glance.

Seville's comfort-engineered interior also affords the improved heating and air-conditioning performance of a

INTERNATIONAL-STYLE TAIL LAMPS HELP DISTINGUISH THE SEVILLE STS.

THE AIR INTAKE AND INTEGRAL FOG LAMPS ENHANCE THE SPORTY CHARACTER OF THE SEVILLE STS.



A SLEEK TEARDROP INSTRUMENT PANEL TURNS THE HORIZON INTO A GENTLE SLOPE. SEVILLE'S AVAILABLE ANALOG INSTRUMENTATION WITH CONSOLE SHIFT IS SHOWN.

rear-compartment vent, which controls air volume and directs air flow precisely to the specifications of rear-seat passengers.

The driving experience remains immediate,



never remote—as you hear the muted notes of the quad exhaust outlets. The electronically controlled powertrain begins with a responsive 4.9 liter V8 with sequential port fuel injection. It generates 200 horse-

power for assertive response. Dual-platinum-tipped spark plugs deliver peak performance for 100,000 miles without replacement. And an electronically controlled transmission with



REAR ELECTRONIC CLIMATE CONTROL VENT.

viscous converter clutch manages this force into a smooth, seamless surge of uninterrupted acceleration.

Seville's taut ride characteristics are the product of many factors. The added strength and rigidity of Seville's all-new body shell assures a solid feel. Its computer-controlled Speed-Sensitive Suspension shifts into the firm mode when control is paramount—at higher speeds or during rapid acceleration, braking or



cornering. Then it reverts into the comfort mode at low speeds when isolation is preferable.

New cast-aluminum alloy wheels reduce unsprung mass for better tire contact on uneven roads. And new tires, designed expressly for the Cadillac Seville, provide all-seasons traction.

The standard anti-lock braking system senses when wheels begin to lock during braking maneuvers on virtually any road surface. Then, it limits such lockup, thus allowing the driver to better maintain steering control on slippery surfaces or during hard braking on dry pavement.



THE SEVILLE'S SPEED-SENSITIVE SUSPENSION AUTOMATICALLY ADJUSTS TO CHANGES IN VEHICLE SPEED AND LATERAL ACCELERATION FOR COMFORT, CONTROL, AND STABLE CORNERING.





A New Approach Creates A Dramatic Departure.

The Eldorado has established a legendary reputation with personal luxury coupe buyers since it was introduced in 1953.

The 1992 Eldorado's design and engineering offer that rare synthesis of character we loved about yesterday with the sophisticated comfort and performance technology we will appreciate about tomorrow.

The 1992 Cadillac Eldorado.  
The pure joy of driving returns.



E L D O R A D O



## A New Approach Creates A Dramatic Departure.

The Eldorado has established a legendary reputation with personal luxury coupe buyers since it was introduced in 1953.

The 1992 Eldorado's design and engineering offer that rare synthesis of character we loved about yesterday with the sophisticated comfort and performance technology we will appreciate about tomorrow.

The 1992 Cadillac Eldorado. The pure joy of driving returns.

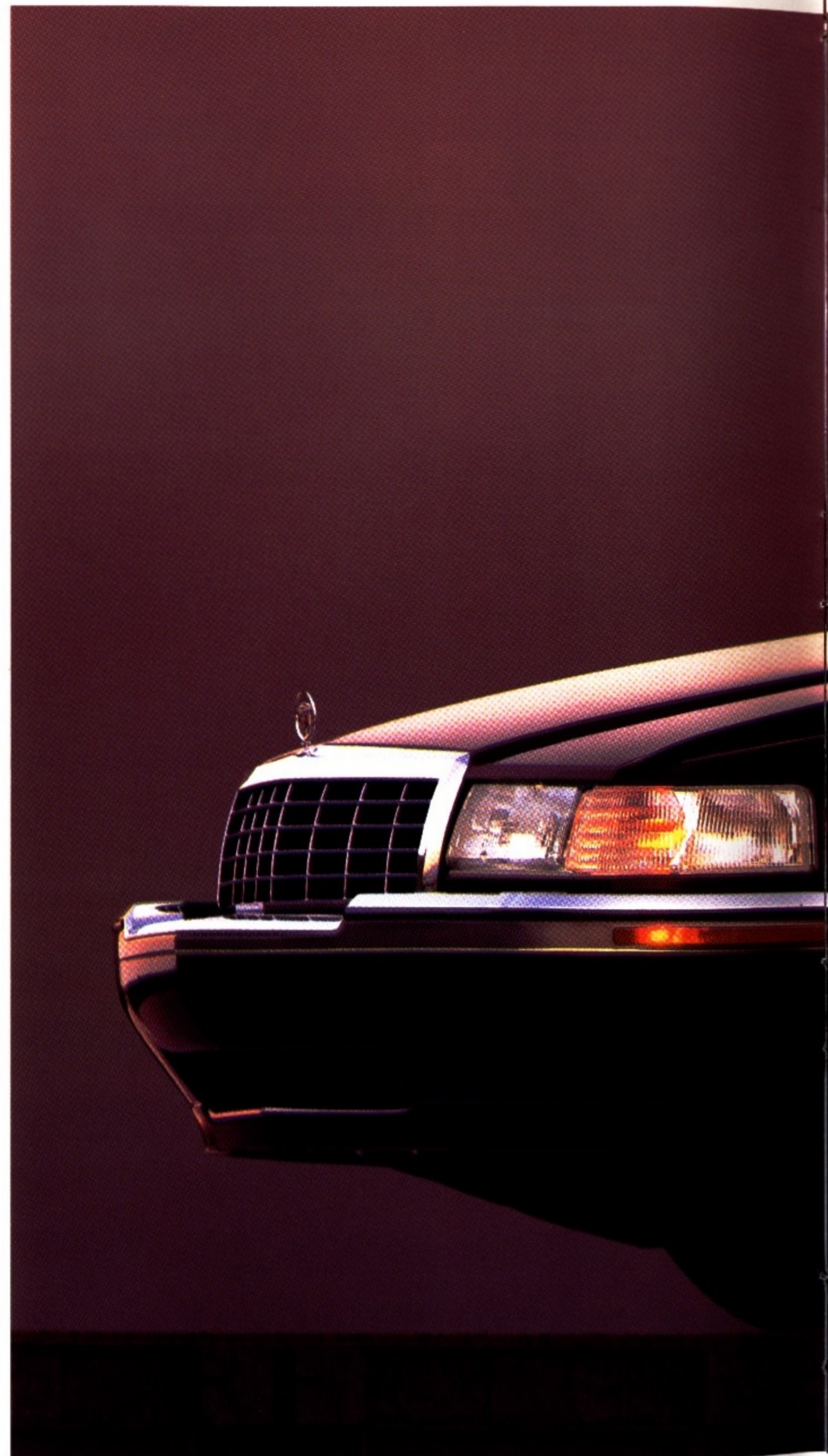

SMOOTH AERODYNAMICS  
AND A RIGID BODY FRAME  
ENHANCE ELDORADO'S  
AGILE PERFORMANCE.

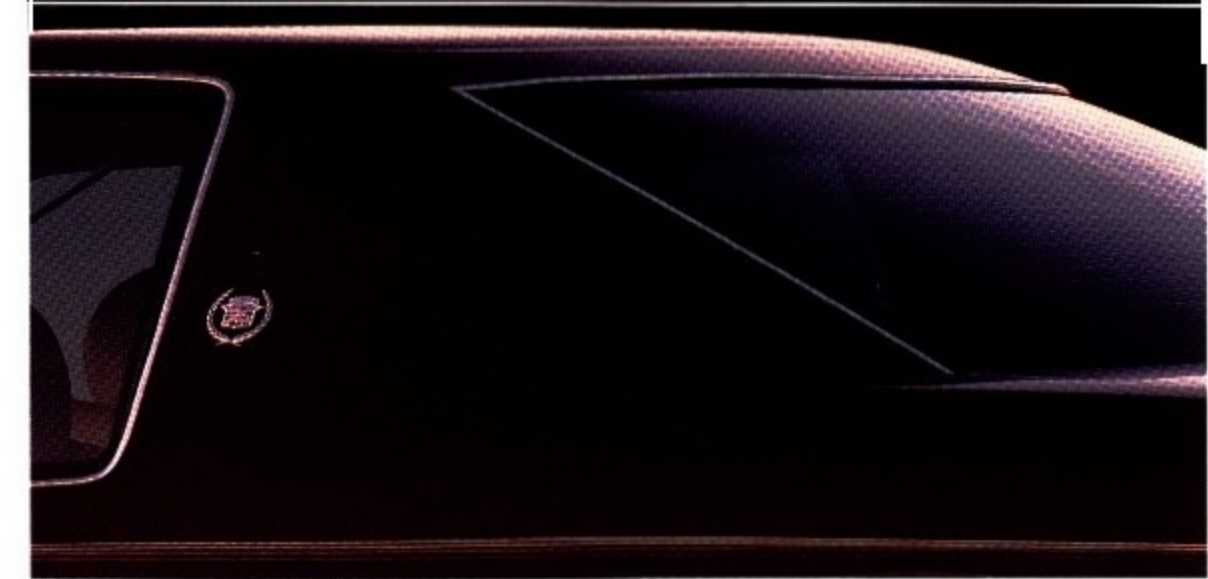

Performance takes shape upon settling behind the wheel. Your first inclination will be to buckle in, turn the key, shift into drive and press the accelerator.

Power is spirited, smooth, instantaneous. Ride and handling systems react to changing driving conditions.

Even the Eldorado's new body structure, with its increased strength and solidity, further refines the driving experience.



## A Refined Difference.

The all-new interior of the Cadillac Eldorado takes your comfort very personally. Its seats are ergonomically contoured to conform to your physique for greater comfort. Its flowing dash, accented in Zebrano wood, places essential controls within easy reach. Interior surfaces share an understated matte finish and matching grain.



THE ELDORADO'S CENTER ARMREST CONCEALS A CONVENIENT STORAGE AREA DESIGNED TO ACCOMMODATE COMPACT DISCS AND CASSETTES.



ELDORADO INTERIOR SHOWN WITH AVAILABLE NEUTRAL LEATHER SEATING AREAS.

The Eldorado Touring Coupe, totally created from the inside out for spirited performance. Where integrated systems of mechanics and electronics work in harmony. Where, every fraction of a second,

computer-controlled driving systems adapt to changes in speed, weather, and driver input. And where every detail focuses on your need for control and comfort to create a total driving experience.



# E L D O R A D O T O U R I N G C O U P E



ELDORADO TOURING COUPE SHOWN IN SABLE BLACK.

## Personal Space.

The touch of glove-soft leather. The appearance of linear-grained Zebrano wood. And the clarity of backlit analog instrumentation. The Eldorado Touring Coupe integrates these elements and others to create a truly driver-focused environment.

Its front seats, sculpted to match the contours of your body, include an innovative power lumbar support that moves up and down within the seatback for tailor-made comfort. And within the seats are two sets of new Dual-Constant springs, one that supports you, and the second that moves you in unison with ride motions to keep you in touch with the road.



**HAND-FITTED NUANCE LEATHER, TAILORED TO THE SEATING AREAS OF THE ELDORADO TOURING COUPE, UNDERGOES A NATURAL TANNING PROCESS THAT MAKES IT BOTH SUPPLE AND RESISTANT TO WEAR CAUSED BY ABRASION AND ULTRAVIOLET LIGHT.**



ELDORADO TOURING COUPE INTERIOR SHOWN WITH NEUTRAL LEATHER SEATING AREAS.

## The Joy Of Driving Returns.



The new Cadillac Eldorado is designed to satisfy the most discriminating driving enthusiast. Surveying the instrument panel, you note how essential controls are thoughtfully placed to allow for an unobstructed view. They switch on and off with uniform consistency and reassuring reliability—proven in tests that spanned a 160° temperature range.

Within arm's reach, a teardrop-shaped instrument panel turns the horizon into a gentle slope. Openness and order are everywhere you look.

The responsive 4.9 liter V8 is sequential port fuel-injected to generate 200 horsepower for responsive performance when you need it the most.

Then it is electronically controlled with a proven transmission to generate a seamless surge of acceleration, barely perceptible shifts, and impressive highway mileage—EPA estimated 25 MPG highway.



ESSENTIAL CONTROLS ARE THOUGHTFULLY PLACED TO ALLOW AN UNOBSTRUCTED VIEW. ELDORADO'S STANDARD DIGITAL INSTRUMENTATION WITH COLUMN SHIFT IS SHOWN.



AN AVAILABLE DELCO/BOSE GOLD SERIES SOUND SYSTEM, CUSTOM-EQUALIZED TO ELDORADO'S ALL-NEW INTERIOR, GENERATES 200 WATTS OF POWER FOR IMPRESSIVE CLARITY AT HIGHER LISTENING LEVELS.

Eldorado's sophisticated powertrain is paralleled by its fully independent Speed-Sensitive Suspension. At low speeds, it isolates you from poor road conditions. At higher speeds, during aggressive cornering, and as you brake or accelerate, it retunes itself to give you impressive control.

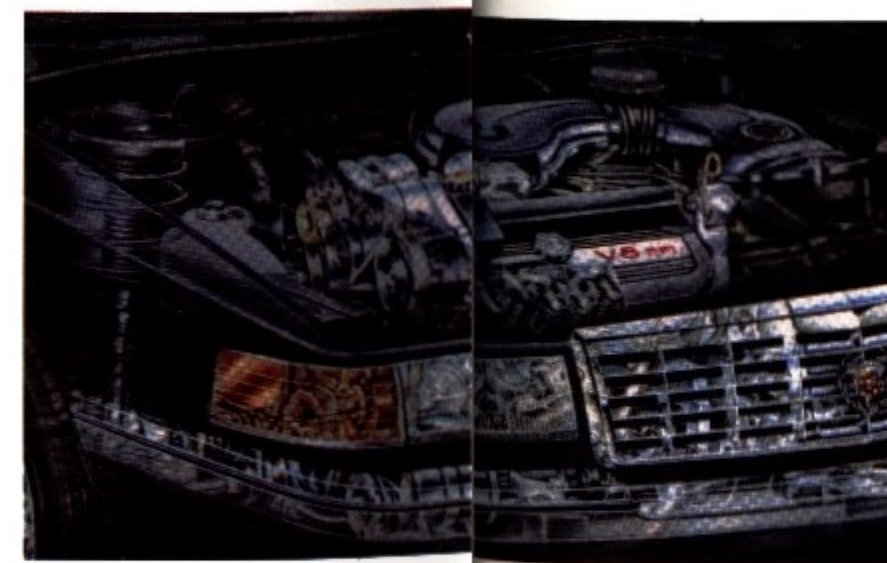

In addition, Eldorado's responsive performance benefits from the increased strength and solidity of its all-new body-frame. Its new Michelin touring tires let you approach winding pavement with confidence. And improved aerodynamics help you slice through the wind with but a whisper.



THE SPEED-SENSITIVE SUSPENSION IS CONSTANTLY ADJUSTING TO CHANGES IN VEHICLE VELOCITY AND ATTITUDE FOR ROAD ISOLATION AND STABLE HANDLING.

OVER 15 CUBIC FEET OF LUGGAGE SPACE AFFORDS YOU PLENTY OF ROOM FOR STORAGE. LOW LIFT-OVER HEIGHT HELPS YOU LOAD AND UNLOAD HEAVY ITEMS WITH GREATER EASE.



## 1992 ELDORADO SELECTED STANDARD FEATURES

### CADILLACS OFFERED IN THIS SERIES

MODEL	COUPE
Eldorado	■
Eldorado Touring Coupe	■

### CADILLAC-EXCLUSIVE TOTAL OWNERSHIP PRIORITY SERVICES†

- Cadillac 4-year/50,000-mile Gold Key Bumper to Bumper Warranty and 6-year/100,000-mile rust-through protection.\* There is no deductible
  - Cadillac Consumer Relations Center—1-800-458-8006
  - Gold Key Delivery System
  - Cadillac Roadside Service, †
- †For additional information, please see pp. 14-15  
\*See your dealer for terms of these limited warranties

### COMFORT AND CONVENIENCE

- Acoustic improvements
- Climate control, electronic—with constant outside temperature display, and additional rear-compartment air duct
- Mirror, illuminated—passenger visor vanity, with variable intensity lighting
- Retained accessory power
- Solar sensor—two-way electronic
- Windows—Soft-Ray, tinted glass

### SEATING/INTERIOR

- Armrest, front-seat center (with storage) and rear-seat center
- Assist handles, center pillar
- Floor carpet, 18-oz. Twilight
- Garage door opener retainer—and sunglass storage compartment (not available with Astrorooft)
- Interior trim, Zebrano wood—instrument panel and door fronts
- Reading lamps, front- and rear-seat
- Seats, knit cloth: front bucket with six-way power seat adjusters, manual seat recliners, adjustable headrests and seat-back pockets; integral rear headrests

### MUSIC SYSTEM

- Antenna, power
  - Delco Electronics Sound System: AM stereo\*\*/FM stereo radio with Dolby, auto-reverse cassette tape player
- \*\*Receives C-Quam, stereo broadcasts. Most AM stereo stations across the country broadcast in C-Quam, but some do not. Check with your local stations for compatibility in your area.

### CONTROLS AND INSTRUMENTATION

- Clock, digital display—in radio
- Computer diagnostics
- Cruise control
- Defogger, electric rear-window
- Defogger, front side windows
- Door locks—power
- Driver information center

- Fuel filler door release—power
- Illuminated entry system
- Indicators—oil life and low fluid levels
- Instrument cluster, digital
- Luggage compartment lid release and pull-down—power

- Safety belts, manual lap/shoulder—outboard front/rear seat positions (accommodates child seat)
- Stop lamp, center high-mounted—integrated into package shelf
- Supplemental Inflatable Restraint System (air bag) in steering wheel hub



**ELDORADO WITH AVAILABLE ANALOG INSTRUMENT PANEL, CONSOLE SHIFT AND FULL CONSOLE.**



**ELDORADO WITH STANDARD DIGITAL INSTRUMENT PANEL, COLUMN SHIFT AND MINI-CONSOLE.**

- Mirrors, heated outside rearview—power
- Steering, Tilt-Wheel, adjustable—leather-trimmed rim
- Trip odometer—push-to-reset
- Twilight Sentinel, †
- Windows, power; includes express-down driver window
- Windshield wiper, controlled cycle, with both speed-set and demand wash cycles

### APPEARANCE AND PROTECTION

- Brake/transmission shift interlock (apply brake pedal to shift from park)
- Bumper fascia, one-piece wraparound—front and rear
- Cornering lamps, front
- Galvanized steel, two-side, in all body and underbody panels (except roof)
- Headlamps, composite tungsten halogen
- Luggage compartment, carpeted
- Paint finish—clearcoat for rich luster
- PASS Key, theft-deterrent system
- Safety belt, manual lap—center rear-seat position



**STANDARD 16"x17" CAST ALUMINUM ALLOY WHEEL—ELDORADO.**



**STANDARD 16"x17" CAST ALUMINUM ALLOY WHEEL—ELDORADO TOURING COUPE.**

### ENGINE/CHASSIS

- 4.9 liter V8 with sequential port fuel injection
- Alternator, 140-ampere
- Anti-lock brake system
- Battery—Delco Freedom, III
- Electronic level control
- Exhaust system, stainless steel—from manifold back
- Front-wheel drive
- Integral body-frame
- Parking brake release, automatic—with single stroke apply
- Spare tire—compact
- Spark plugs, dual-platinum-tipped—for 100,000-mile service intervals
- Speed-Sensitive Suspension—with automatic, three-position, electronically adjustable struts
- Stiffer front frame and engine mounts help improve stability, noise and vibration isolation
- Tires—Michelin XGT4 P225/60R16 touring all-seasons blackwall radials
- Transmission, four-speed automatic—with electronic shift control, overdrive and Cadillac-exclusive viscous converter clutch

## ELDORADO TOURING COUPE

### ADDITIONAL STANDARD FEATURES

#### COMFORT AND CONVENIENCE

- Mirrors, illuminated—driver/passenger visor vanity with variable intensity lighting

#### SEATING/INTERIOR

- Console, full front floor—with Zebrano wood trim and shift lever
- Floor mats, front and rear—23-oz. Twilight
- Seats: 12-way power front bucket (including four-way lumbar adjustment); Nuance leather seating areas with specific gathered appearance; power seat recliners; manual articulating headrests, front seatback pockets



**STANDARD PAINTED METAL ROOF SHOWN WITH AVAILABLE ASTROROOF (REDUCES HEADROOM SLIGHTLY).**

### MUSIC SYSTEM

- Delco Electronics Sound System: AM stereo\*\*/FM stereo radio with Dolby, auto-reverse cassette tape player and six speakers

### CONTROLS AND INSTRUMENTATION

- Instrument cluster—analogue
- Mirrors, heated outside rearview with blue-tinted glare-resistant glass and breakaway design—power



**AVAILABLE MICHELIN TOURING WHITEWALL RADIAL.**

### APPEARANCE AND PROTECTION

- Deck lid carpet liner
- Fog lamps—mounted into front fascia
- Identification—Touring Coupe in door molding
- Lamp, underhood
- Mat, luggage compartment
- Security package: Includes remote keyless entry, automatic door locks with central door unlocking and theft-deterrent system
- Wreath and crest flush-mounted on grille

### ENGINE/CHASSIS

- Quad exhaust outlets
- Speed-Sensitive Suspension—touring version
- Tires, Goodyear Eagle GA P225/60HR16 performance steel-belted all-seasons blackwall radials

### SELECTED AVAILABLE FEATURES

Available option package that you may order

- Eldorado option package ISB<sup>1</sup>:  
Floor mats, front and rear—23-oz. Twilight  
Lamp, underhood  
Mat, luggage compartment  
Mirror, illuminated—driver visor vanity with variable-intensity lighting

Available features that you may order individually

### COMFORT AND CONVENIENCE

- Mirror, inside rearview—automatic dimming—Electrochromic

### SEATING/INTERIOR

- Leather seating areas—Nuance<sup>1</sup>
- Four-way lumbar adjustments and seat recliners—power, manual articulating headrests<sup>1</sup> (requires available leather seating areas)
- Heated front seats (requires available leather seating areas)

### MUSIC SYSTEM

- Delco/Bose Gold Series Sound System: AM stereo\*\*/FM stereo radio with combined Dolby, auto-reverse cassette tape and compact disc players

### CONTROLS AND INSTRUMENTATION

- Analog cluster with floor shift and full console<sup>1</sup>
- Windshield, heated

### APPEARANCE AND PROTECTION

- Accent striping—Eldorado only
- License plate mounting, front—no charge
- Paint, Firemist
- Security package: Includes remote keyless entry, automatic door locks with central door unlocking and theft-deterrent system<sup>1</sup>

### ENGINE/CHASSIS

- Tires—Michelin XGT4 P225/60R16 touring all-seasons whitewall radials (Eldorado only)
- <sup>1</sup>Standard on Eldorado Touring Coupe

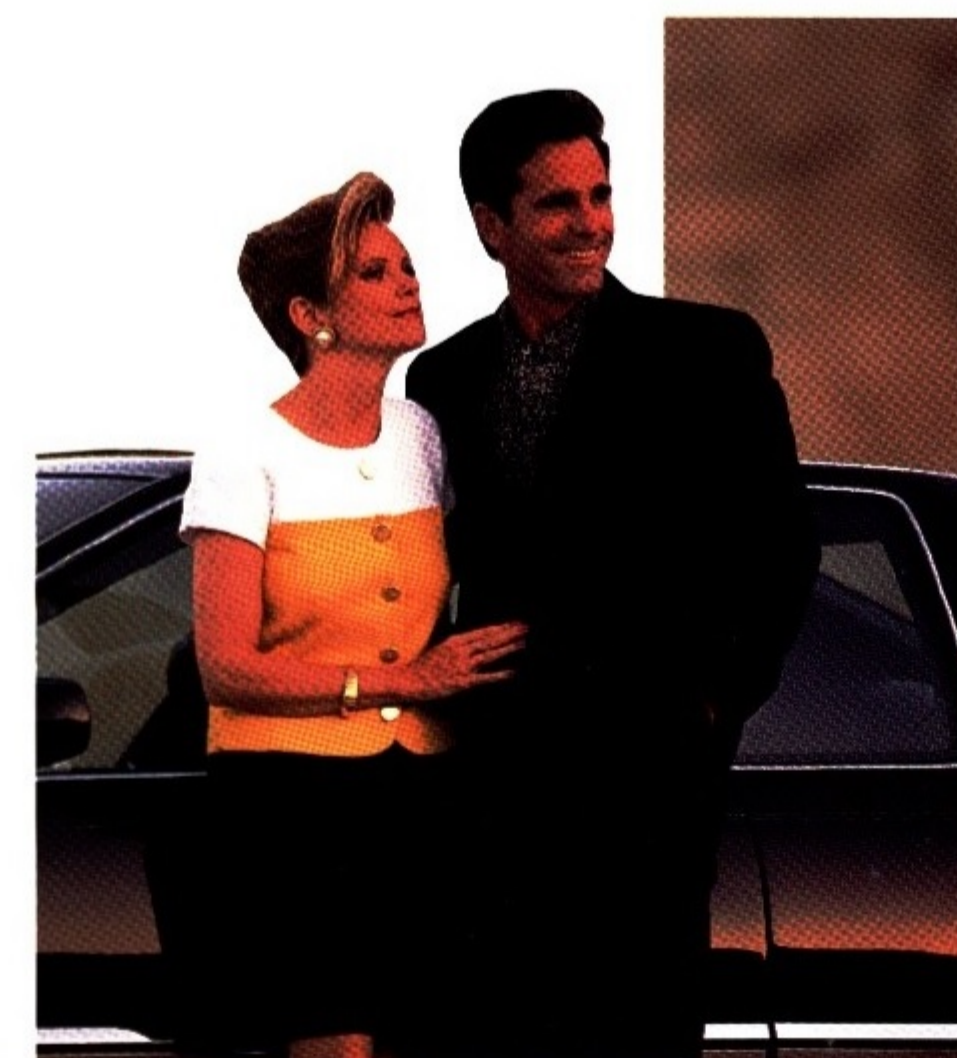

## SPECIFICATIONS

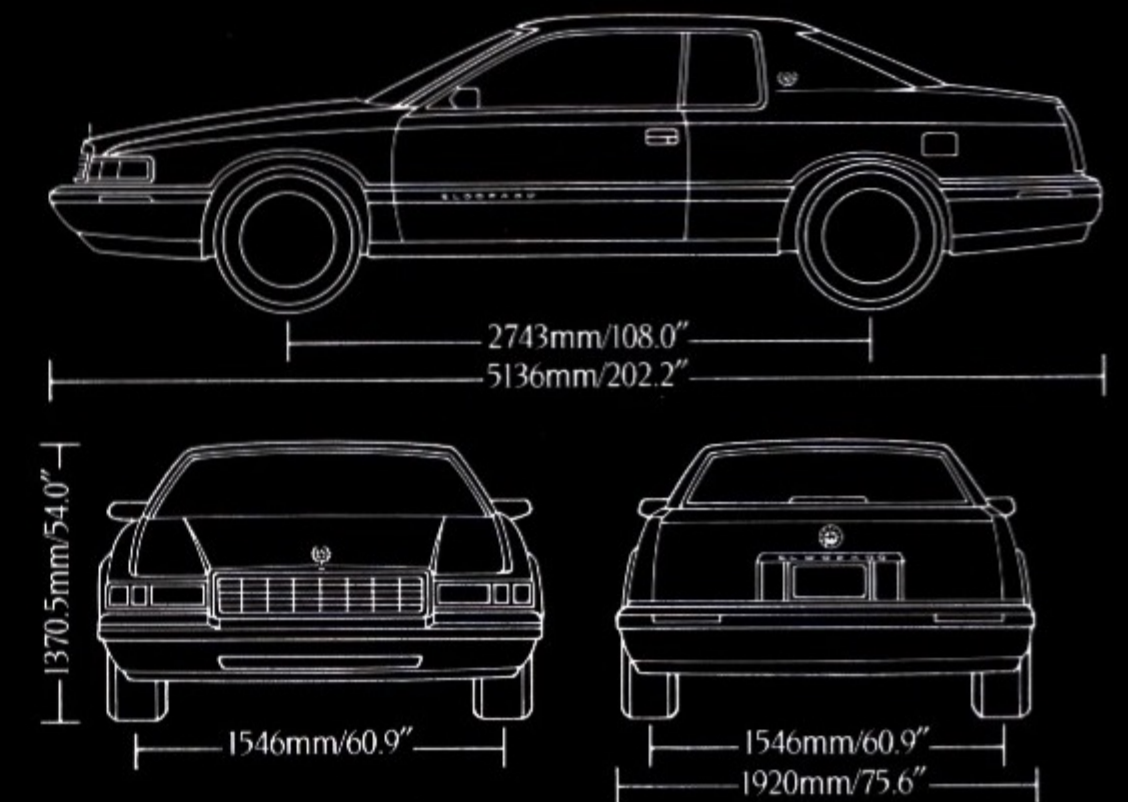

## 1992 ELDORADO

Engine	4.9 liter V8 with sequential port fuel injection
Power	200 bhp @ 4100 rpm
Torque	275 lbs.-ft. @ 3000 rpm
Recommended fuel/tank capacity	Unleaded premium/18.8 gallons usable
Transmission	Four-speed automatic with electronic shift control, overdrive and Cadillac-exclusive viscous converter clutch
Final drive ratio (effective)	
Eldorado	2.97:1
Eldorado Touring Coupe	3.33:1
Suspension	
Eldorado	Speed-Sensitive Suspension, fully independent with specific tuning and rear electronic level control
Eldorado Touring Coupe	same as above, plus specific calibration and touring version components: rear stabilizer bar, firmer front/rear strut valving, higher variable rate front springs, higher rate front bushings and cradle mounts
Steering	Power-assisted rack and pinion; 16.5:1 ratio
Brakes	Bosch III, anti-lock; power four-wheel disc
Wheels	16"x17" cast aluminum alloy, specifically designed for each car
Tires	
Eldorado	Michelin P225/60R16 touring steel-belted all-seasons blackwall radials
Eldorado Touring Coupe	Goodyear Eagle GA P225/60HR16 performance steel-belted all-seasons blackwall radials

## DIMENSIONS

Headroom		
Front	960mm/37.8"	Rear: 972mm/38.3"
Legroom		
Front	1082mm/42.6"	Rear: 915mm/36.1"
Hip room		
Front	1468mm/57.8"	Rear: 1416mm/55.8"
Shoulder room		
Front	1478mm/58.2"	Rear: 1463mm/57.6"
Seating capacity front/rear	2/3	
Curb weight		
Eldorado	1634.9kg/3604lbs.	
Eldorado Touring Coupe	1651.1kg/3640lbs.	
Luggage capacity	0.44 cu. m/15.3 cu. ft.	

Specifications as of 8-91

**STANDARD ELDORADO SCULPTURED KNIT CLOTH INTERIOR.**



Allanté's high-performance capabilities can be enjoyed all year round by virtue of advanced Traction Control and Bosch III anti-lock braking. The Speed-Sensitive Suspension adapts to

changing driving patterns automatically. The handcrafted Italian coachwork, roomy interior dimensions and Delco/Bose Gold Series Sound System help make long excursions as invigorating

as short ones. And Allanté affords you the reassurance of one of the finest vehicle protection plans of any automobile sold in America.



# A L L A N T É



A  
L  
L  
A  
N  
T  
É

ALLANTÉ SHOWN IN RED.

## Room With A View.

Allanté affords you uncommon levels of roominess and comfort. Hand-matched Italian leather is tailored to the seating areas of its 10-way Recaro® bucket seats. And Allanté's quiet aerodynamics let you and your passenger hold a normal conversation with the top down at highway speeds.

Standard amenities include power headlamp washers, express-down windows, central door unlocking, and a power-latching roof design. Plus a Delco/Bose Gold Series Sound System, with both compact disc and cassette, custom equalized to the contours and textures of the interior in which it performs.



A DRIVER'S-SEAT MEMORY RECALLS TWO PREFERRED SEATING POSITIONS AND A PROGRAMMABLE EXIT SETTING.



ALLANTÉ INTERIOR SHOWN WITH CHARCOAL LEATHER SEATING AREAS.

## A Technological Tour De Force.

A fraction of a second. Precious little time to grasp the measure of America's ultra-luxury roadster. Yet in the 1992 Allanté it is time enough for system upon system to react and respond.

It begins with the smooth surge of a 4.5 liter V8 that generates 200 horsepower and 270 lbs.-ft. of torque for exhilarating performance over a wide range of speeds. Inside, dual-platinum-tipped spark plugs afford you 100,000 miles of peak performance without replacement.



THE COCKPIT OF THE ALLANTÉ INVITES DRIVER INVOLVEMENT.

comprehensive insurance premium discounts.

The most extensive array of advanced technology in Cadillac history. Creating a driving experience that, while years in the making, takes but a fraction of a second to appreciate.



ALLANTÉ'S GENEROUS LUGGAGE SPACE FEATURES A PASS-THROUGH DESIGN TO ACCOMMODATE GOLF CLUBS, SKIS AND MORE.



If only one wheel slips during acceleration, Traction Control applies brake pressure to the slipping wheel exclusively, allowing the remaining drive wheel to transmit engine torque.

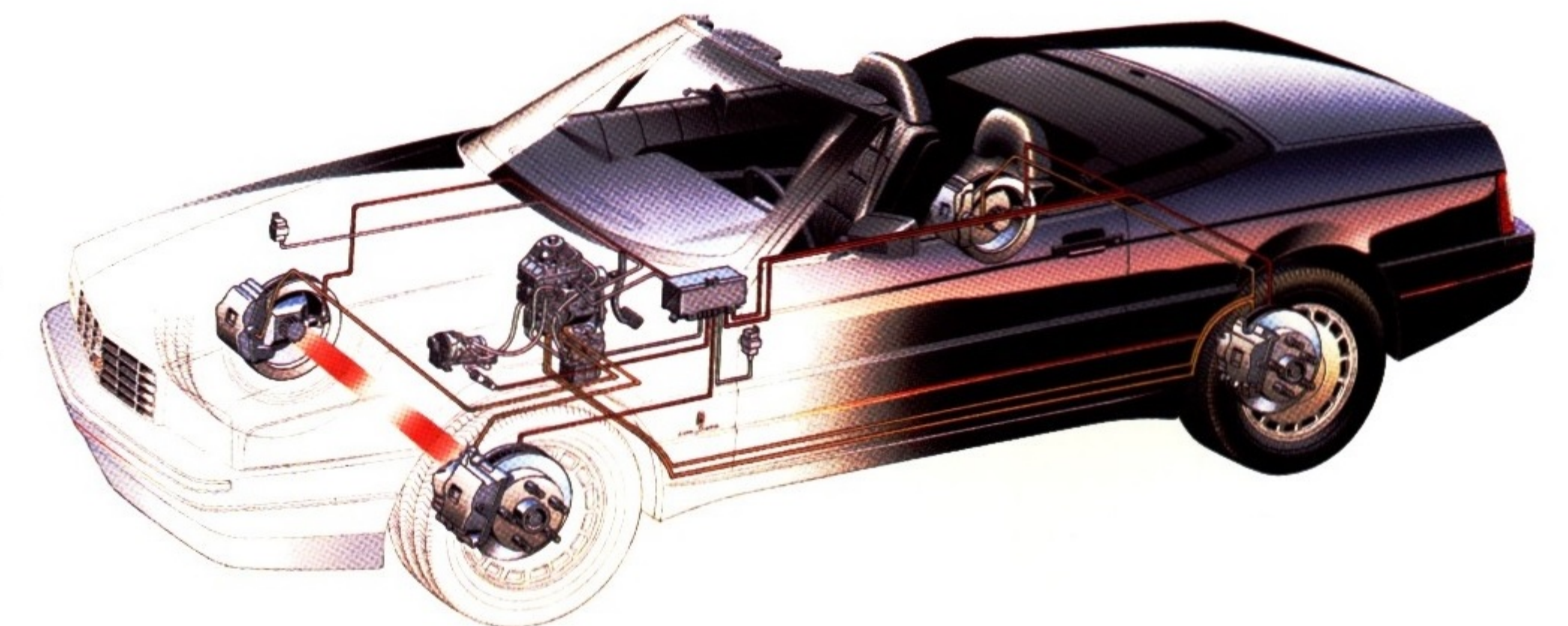

Simultaneously, Allanté's electronically controlled Speed-Sensitive Suspension automatically retunes itself to match changing speeds. Its speed-sensitive variable assist steering adapts for highway stability or parking ease. A driver's-side air bag stands ready to help protect you in milliseconds. And Allanté is equipped with a theft-deterrent system so sophisticated, it commands the engine control computer to refuse engine start-up, and may qualify you for

seconds or more, engine output is gradually reduced. The result: maximum traction on virtually any road surface.



This power is then managed by the Cadillac Allanté's advanced Traction Control system, which employs the anti-lock brake computer and controls engine output. If the sensors for Allanté's anti-lock braking system detect wheel spin upon acceleration, they signal the ABS computer to limit wheel spin, thereby improving available traction. When Traction Control is engaged for three

TUNED AIR INTAKE RUNNERS IN THE HIGH-OUTPUT V8 PACK AIR MORE DENSELY IN THE CYLINDER TO PRODUCE GREATER POWER.



# ALLANTÉ - SPECIFICATIONS



THE ALUMINUM HARDTOP WEIGHS ONLY 58 POUNDS, AND FASTENS QUICKLY INTO PLACE. INCLUDES HEATED GLASS REAR WINDOW AND GLASS QUARTER WINDOWS.



ALLANTÉ'S POWER-LATCHING SOFT-TOP DESIGN FEATURES GAS-STRUT ASSIST, ELECTRICALLY HEATED GLASS REAR WINDOW AND GLASS QUARTER WINDOWS.



THE OPEN-CAR AERODYNAMICS OF ALLANTÉ TURN THE WIND INTO A WHISPER, ALLOWING YOU TO HAVE A NORMAL CONVERSATION AT HIGHWAY SPEEDS WITH THE TOP DOWN.

## 1992 ALLANTÉ SELECTED STANDARD FEATURES

### CADILLAC OFFERED IN THIS SERIES MODELS

Allanté Hardtop/Convertible with hard and soft top; your choice of digital or analog instrument panel

Allanté Convertible including soft top and analog instrument panel

### CADILLAC-EXCLUSIVE TOTAL OWNERSHIP PRIORITY SERVICES\*

■ Allanté Assurance Plan—4-year/50,000-mile bumper-to-bumper warranty, including free towing and a portfolio of other services, and 7 years/100,000 miles on powertrain, major assembly components and rust-through protection\*. There is no deductible

■ Allanté Hotline: 1-800-ALLANTÉ—24-hour toll-free assistance from a professionally trained Allanté specialist

■ Cadillac Consumer Relations Center—factory-trained assistance available 24 hours a day, 365 days a year at 1-800-458-8006

■ Gold Key Delivery System

■ Cadillac Roadside Service—professional help is a toll-free call away (1-800-882-1112), 24 hours a day, 365 days a year. You get on-the-spot assistance

nights, weekends and holidays  
†For additional information, please see pp. 14-15  
\*See your dealer for terms of these limited warranties

### COMFORT AND CONVENIENCE

- Climate control, electronic—with outside temperature display
- Solar sensor
- Visors, padded dual sun

### SEATING/INTERIOR

- Armrests, door—leather-trimmed
- Console—includes leather-trimmed armrest; ash receiver, cigarette lighter, storage compartment with coin holder, release buttons for fuel filler door and luggage compartment; leather-trimmed shift selector
- Floor carpet, Tiffany
- Floor mats, carpeted
- Headrests, two-way adjustable—leather-trimmed
- Lamps, exterior—including fog, low- and high-beam composite headlamps with unique lamp-out substitution feature
- Lamps, interior—including foot well, overhead courtesy/map, door-mounted warning/courtesy, underhood, luggage compartment

- Luggage compartment with pass-through door; total capacity, 16.3 cubic feet
- Seatback pockets
- Seats, Recaro, ten-way power, including recliners/lumbar supports and leather seating areas with French seams. Driver seat includes two memory settings plus "exit" feature



STANDARD DELCO/BOSE GOLD SERIES SOUND SYSTEM INCLUDES AUTO-REVERSE DOLBY, CASSETTE TAPE PLAYER AND THE STUNNING REALISM OF COMPACT DISCS.

### MUSIC SYSTEM

- Antenna, power
- Delco/Bose Gold Series Sound System: AM stereo\*\*/FM stereo radio with combined compact disc and Dolby, auto-reverse cassette tape players; custom-equalized for Allanté interior



ANALOG INSTRUMENT PANEL.



DIGITAL INSTRUMENT PANEL.

### CONTROLS AND INSTRUMENTATION

- Clock, digital display
- Computer diagnostics
- Convertible top—power latching
- Cruise control
- Defogger, electric rear glass window in both convertible top and hardtop
- Defogger, front side windows
- Driver information center
- Fuel filler door release—power
- Illuminated entry system
- Indicators—oil life and low fluid levels
- Luggage compartment lid release and pull-down—power
- Mirrors, outside rearview (collapsible)—power, heated
- Steering, Tilt-Wheel, —adjustable with comfort hand-grips and leather-trimmed rim
- Twilight Sentinel
- Washers, headlamp with independent control—power
- Windows, express-down, driver and passenger—power
- Windshield wiper system, high-performance controlled-cycle—with wet-arm design washer

### APPEARANCE AND PROTECTION

- Body panels, side—two-side galvanized steel; aluminum hood, roof and deck lid
- Bumper fascia, one-piece wraparound—front and rear
- Central door unlocking from doors and luggage compartment lock

\*\*Receives C-Quam, stereo broadcasts. Most AM stereo stations across the country broadcast in C-Quam, but some do not. Check with your local stations for compatibility in your area.

- Safety belts, manual lap/shoulder—driver and passenger
- Mat, luggage compartment



ALLANTÉ'S ADVANCED SPEED-SENSITIVE SUSPENSION REACTS AUTOMATICALLY TO CHANGING VEHICLE SPEEDS FOR INCREASED CITY COMFORT OR HIGHWAY CONTROL. VARIABLE ASSIST STEERING PROVIDES PARKING EASE.

- Paint finish, clearcoat for a rich luster
- Stop lamp, center high-mounted
- Supplemental Inflatable Restraint System (air bag) in steering wheel hub
- Theft-deterrent systems, PASS Key, and audible alarm



A TOOTHED RING SENDS SIGNALS TO TWO PARALLEL COMPUTERS TO OPERATE ALLANTÉ'S ADVANCED ABS AND TRACTION CONTROL SYSTEMS.

### ENGINE/CHASSIS

- 4.5 liter high-output V8 with tuned sequential port fuel injection
- Alternator, 124-ampere
- Anti-lock brake system—Bosch III
- Battery, heavy-duty—Delco Freedom, III
- Exhaust system, stainless steel—from manifold back
- Front-wheel drive



A WASHER HELPS KEEP ALLANTÉ'S INTEGRATED HEADLAMP/FOGLAMP CLEAN FOR MAXIMUM VISIBILITY.

- Parking brake release, automatic—three-stroke apply
- Resonator, air intake—for quiet engine performance
- Spare tire, compact
- Spark plugs, dual-platinum-tipped—for 100,000-mile service intervals
- Speed-Sensitive Suspension—with automatic three-position electronically adjustable struts
- Steering, variable assist
- Traction Control with instrument panel indicator
- Transmission, four-speed automatic—with electronic shift control, overdrive and Cadillac-exclusive viscous converter clutch



### AVAILABLE FEATURES

#### AT NO EXTRA COST

- Analog instrumentation—Hardtop/Convertible
- License plate mounting provisions—front

### AVAILABLE FEATURES

#### AT EXTRA COST

- Instrument panel, digital—Convertible
- Paint, Pearl White—Convertible

## SPECIFICATIONS

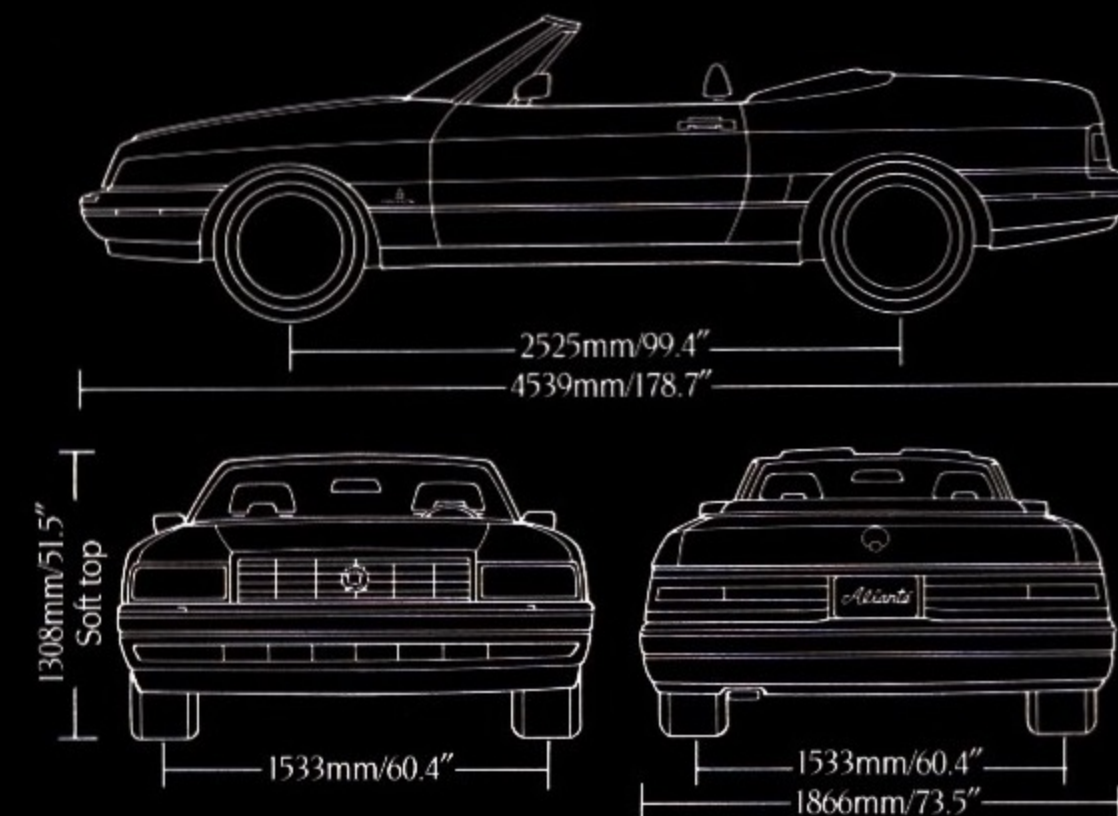

## 1992 ALLANTÉ

Engine	4.5 liter high-output V8 with tuned sequential port fuel injection
Power	200 bhp @ 4400 rpm
Torque	270 lbs.-ft. @ 3200 rpm
Traction Control	Standard, Bosch III electronic system
Recommended fuel/tank capacity	Unleaded premium/22.0 gal. usable
Transmission	Four-speed automatic with electronic shift control, overdrive and Cadillac-exclusive viscous converter clutch
Final drive ratio (effective)	Performance 3.21:1
Suspension	Speed-Sensitive Suspension; fully independent with front stabilizer bar
Steering	Power variable assist rack and pinion; 15.6:1 ratio
Brakes	Bosch III anti-lock, power four-wheel disc
Wheels	16"x7" forged aluminum alloy
Tires	Goodyear Eagle VL P225/55VR16 steel-belted blackwall radials

## DIMENSIONS

Headroom	
Hardtop/Convertible	944mm/37.2"
Convertible	977mm/38.3"
Legroom	1097mm/43.2"
Hip room	1383mm/54.4"
Shoulder room	1466mm/57.7"
Seating capacity	2
Curb weight	
Hardtop/Convertible	1611kg/3551.7lbs.
Convertible	1583.5kg/3491.1lbs.
Luggage capacity	0.45 cu. m/16.3 cu. ft. (includes 3 cu.-ft. "pass-through" compartment)

Specifications as of 8-91

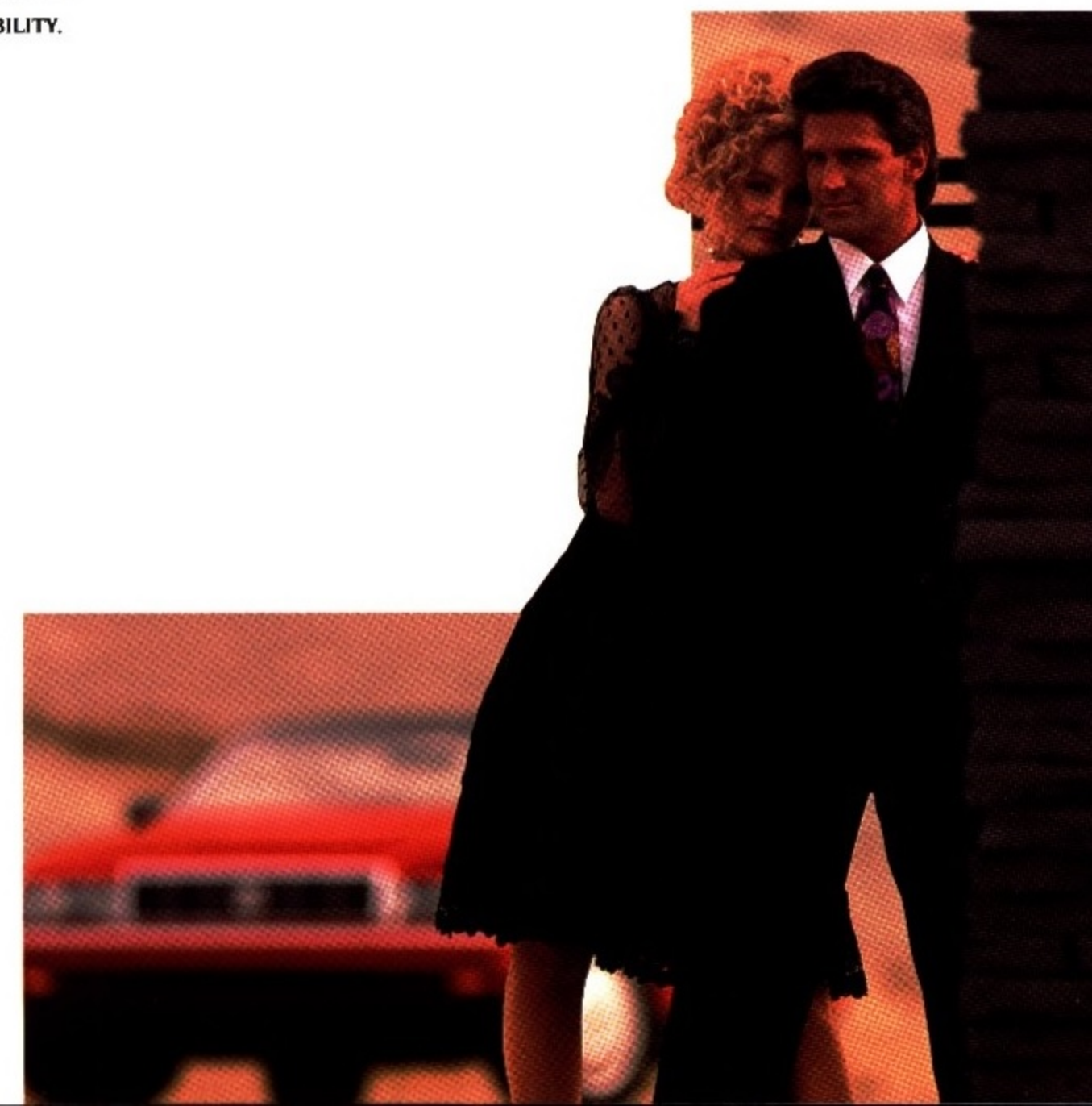

The Cadillac Fleetwood Sedan and Coupe are America's premier full-size luxury automobiles. And they have the added distinction of some of the most sophisticated automotive technology

on the road today. From the added stability of Traction Control to the added control of anti-lock brakes. From the response of an electronically controlled V8 and transmission to the adapt-

ability of Speed-Sensitive Suspension. All standard, and supplemented by comfort and convenience amenities that cater to your every need.



# F L E E T W O O D



FLEETWOOD SEDAN SHOWN IN SABLE BLACK.

F  
L  
E  
E  
T  
W  
O  
O  
D

## Place Yourself In An Envable Position.

**N**owhere is Cadillac's renown for comfort more apparent than in the Fleetwood Sixty Special. Its spacious six-passenger interior is unsurpassed in size among all front-drive sedans sold in America.

It is adorned with supple, hand-finished leather seating areas featuring elegant French seams designed by renowned Italian designer Giorgio Giugiaro. Polished American walnut enhances the instrument panel and doors. And an advanced climate control system includes multi-directional rear-compartment vents for greater passenger comfort.

**P**ATENTED 22-WAY POWER-ADJUSTING FRONT SEATS ARE DESIGNED WITH THE HELP OF LEADING ORTHOPEDIC SPECIALISTS TO PROVIDE EXTRAORDINARY LEVELS OF COMFORT AND BACK SUPPORT.



FLEETWOOD SIXTY SPECIAL INTERIOR SHOWN WITH DARK BLUE LEATHER SEATING AREAS.

## Raise Your Standard Of Living.

The Cadillac Fleetwood satisfies even the highest standards of luxurious living. Accented with polished American walnut, Fleetwood's easy-to-read digital instrument panel and driver information center let you monitor all critical driving systems at a glance.

Fleetwood's advanced climate control system includes a solar sensor that detects sunshine as it enters the passenger compartment and automatically adjusts heating and air conditioning accordingly. And standard amenities include lighted vanity mirrors for driver and front- and rear-seat passengers; leather-trimmed steering wheel; inside and driver outside Electrochromic rearview mirrors that dim automatically to reduce glare; and an illuminated entry system.



FLEETWOOD STANDARD ESTEEM CLOTH INTERIOR SHOWN IN DARK BLUE.



FLEETWOOD INTERIOR SHOWN WITH AVAILABLE LIGHT GRAY LEATHER SEATING AREAS.



## Six-Passenger Luxury Has Never Been So Sophisticated.

The Cadillac Fleetwood offers technology not for its own sake, but for yours. It begins with a 200-horsepower, sequential port fuel-injected 4.9 liter V8 engine. Dual-platinum-tipped spark plugs provide 100,000 miles of peak performance without replacement. And an electronically controlled automatic transmission channels the power generated into a smooth, seamless surge of acceleration.

Speed-Sensitive Suspension adapts itself automatically as you change speed—isolating you from the bumps so common in city driving, then firming at higher speeds for stability and control.

Fleetwood's sophistication is also tailored to your peace



**ELECTROCHROMIC OUTSIDE DRIVER-SIDE REARVIEW MIRROR DARKENS AUTOMATICALLY TO REDUCE GLARE.**

**AN EASY-TO-READ DIGITAL INSTRUMENT PANEL LETS YOU MONITOR CRITICAL DRIVING SYSTEMS AT A GLANCE. THE STEERING WHEEL HUB CONCEALS A STANDARD SUPPLEMENTAL INFLATABLE RESTRAINT.**



of mind. Working in concert with a vast array of safety features, the steering wheel hub conceals a standard driver's-side Supplemental Inflatable Restraint System (air bag). An available remote keyless

entry system can lock and unlock doors and can unlock the deck lid from a 15-foot radius. And the Fleetwood's PASS Key<sup>®</sup>, theft-deterrent system may entitle you to comprehensive insurance premium discounts.

Now the advanced anti-lock braking technology that helps bring your Fleetwood to a controlled stop will help it accelerate as well. It's called Traction Control. And it begins when sensors detect

THE UNMISTAKABLE DISTINCTION OF FLEETWOOD IS ALSO AVAILABLE IN A FULL-SIZE, SIX-PASSENGER COUPE. FLEETWOOD COUPE SHOWN IN BLACK SAPPHIRE.

# FLEETWOOD



Finally, sophistication can enhance your entertainment. Fleetwood's six-speaker sound system—including Delco Electronics AM stereo\*/FM stereo radio and cassette—features a five-band graphic equalizer to let you contour sound to your precise specifications.



**FLEETWOOD'S STANDARD SPEED-SENSITIVE SUSPENSION HELPS ISOLATE YOU FROM POOR ROAD CONDITIONS AT LOW SPEEDS, THEN FIRMS AT HIGH SPEEDS FOR ADDED STABILITY AND CONTROL.**

excessive wheel slip during acceleration at speeds

under 30 miles per hour. Then Traction

Control pulses Fleetwood's anti-lock

brakes faster than humanly

possible to limit wheel spin.

Unwanted wheel slip is minimized

quickly for maximum

traction and

acceleration.

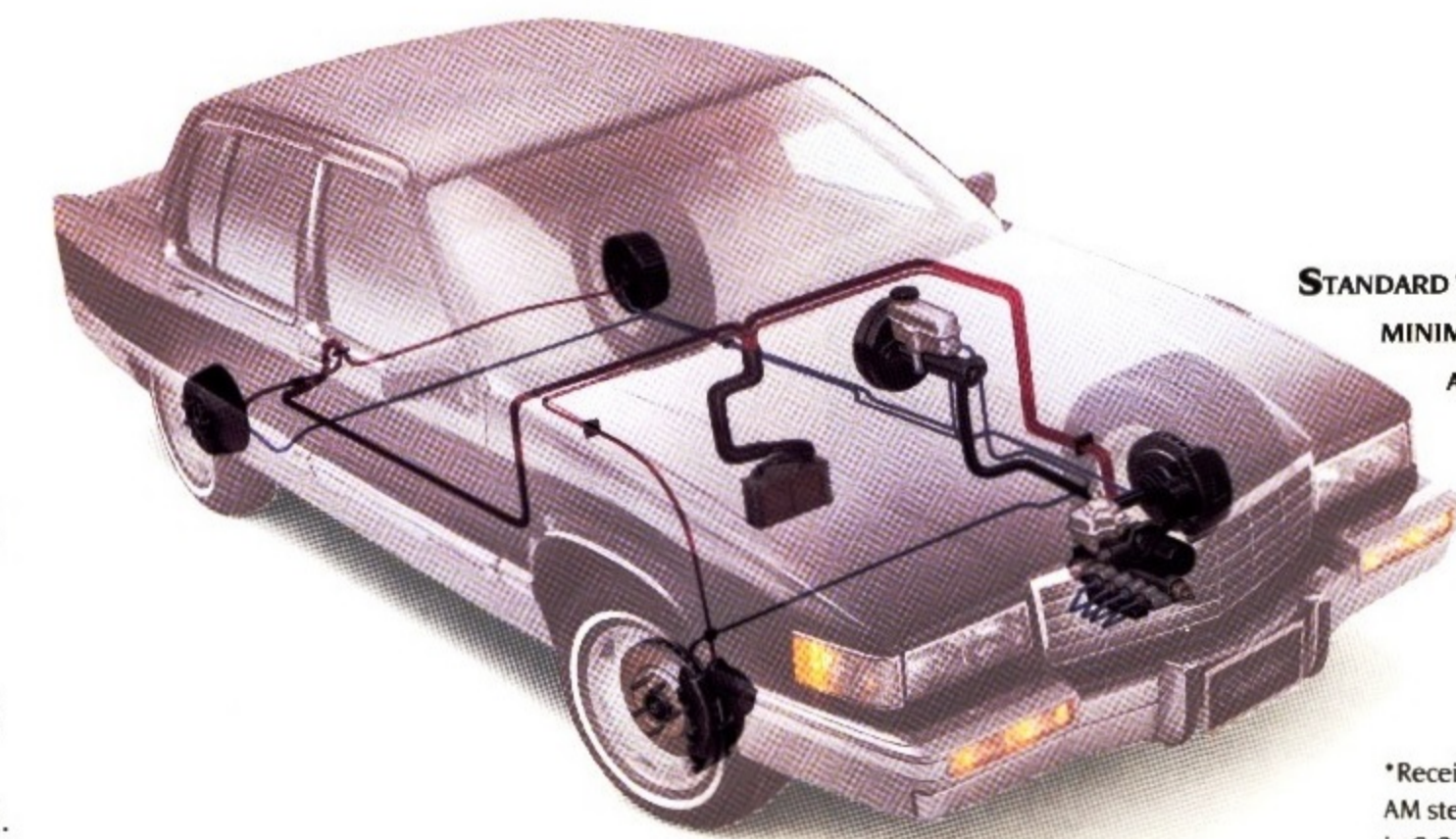
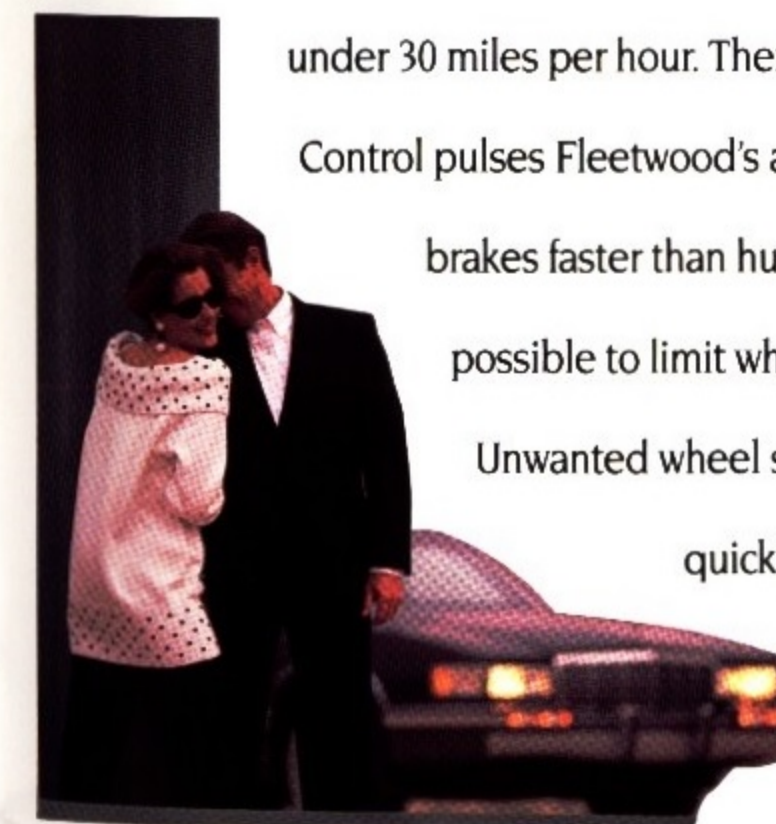

**STANDARD TRACTION CONTROL HELPS MINIMIZE WHEEL SLIP AS YOU ACCELERATE AT SPEEDS UNDER 30 MPH.**

\*Receives C-Quam<sup>®</sup>, stereo broadcasts. Most AM stereo stations across the country broadcast in C-Quam<sup>®</sup>, but some do not. Check with your local stations for compatibility in your area.



The De Ville is America's most preferred Cadillac. It combines the classic virtues of a full-size luxury automobile with contemporary technologies that enhance performance, comfort and

safety. Standard De Ville features include an electronically controlled V8 powertrain. Anti-lock brakes. An advanced electronic climate control system. Automatic door locks. And the six-

passenger comfort afforded by the largest interior of any front-drive sedan sold in America. New for 1992 is optional Traction Control.



# D E V I L L E

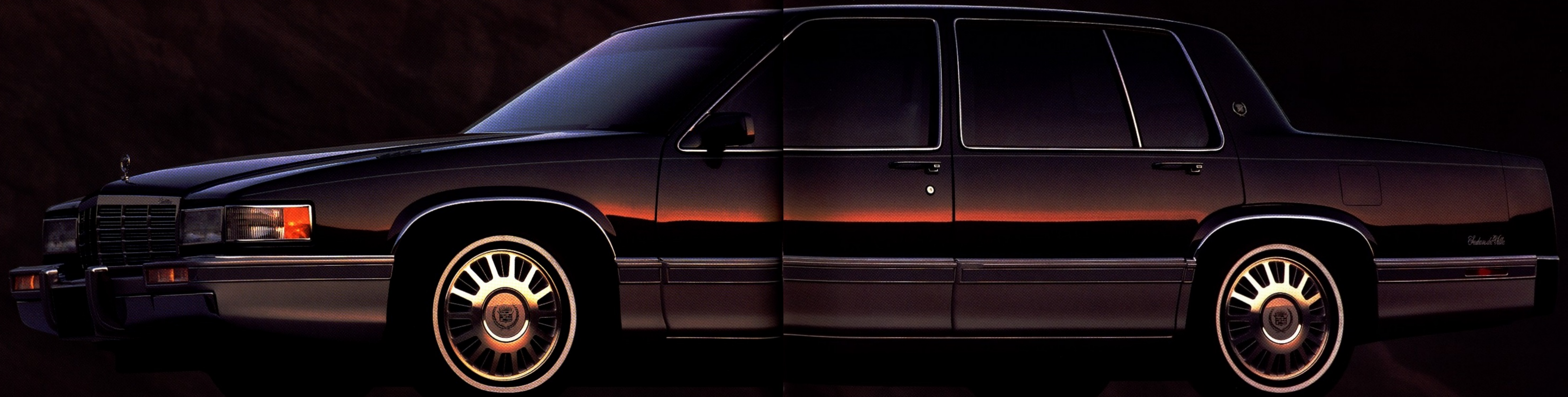

SEDAN DE VILLE SHOWN IN ACADEMY GRAY.

## Enhance Your Margin Of Comfort.

Comfort has always been a hallmark of the Cadillac De Ville. And the 1992 De Ville is no exception. Spanning its spacious interior are six-way power-adjusting front seats, comfort-engineered to leave you refreshed even after extended travel. Supple leather seating areas are available. And an easy-to-read instrument panel puts all controls within convenient reach.

Generous sound-absorbing materials shield you from outside noise. And rear-seat heating/air conditioning vent controls help maintain predetermined interior temperatures.



SOFT ESTEEM CLOTH CREATES AN ADDED TOUCH OF COMFORT AND ELEGANCE.



DE VILLE INTERIOR SHOWN WITH AVAILABLE LIGHT GRAY LEATHER SEATING AREAS.

## First-Class Accommodations.



The 1992 De Ville takes care of you in the manner to which you've become accustomed. Its 4.9 liter V8 with sequential port fuel injection provides 200 horsepower to help you pass and merge with confidence. Its smooth, electronically controlled automatic transmission makes shifts barely detectable. And together, they deliver impressive highway mileage—an EPA-estimated 25 miles per gallon highway.

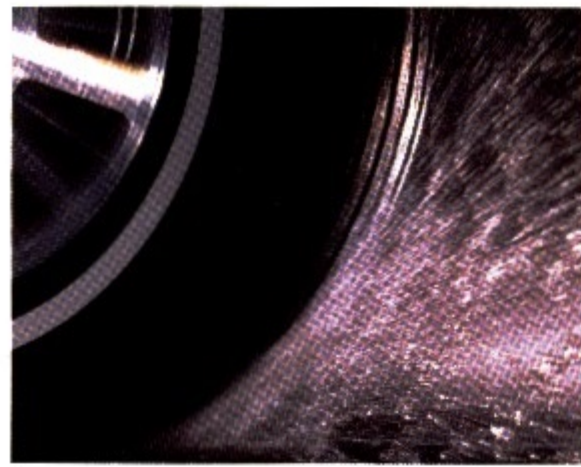

DE VILLE'S STANDARD ANTI-LOCK BRAKING SYSTEM AUTOMATICALLY SENSES WHEN WHEELS SLIP DURING BRAKING ON VIRTUALLY ANY ROAD SURFACE AND PULSES BRAKES TO HELP YOU MAINTAIN STEERING CONTROL.



COUPE DE VILLE SHOWN IN COTILLION WHITE WITH AVAILABLE FULL CABRIOLET ROOF.

De Ville's first-class accommodations also include a vast array of standard amenities. Like an Electrochromic inside rearview mirror that senses when following headlights shine on it and automatically dims to reduce glare. Automatic door locks with central door unlocking. Heated outside rearview mirrors with power adjustment. And a fuel data center, which calculates your average

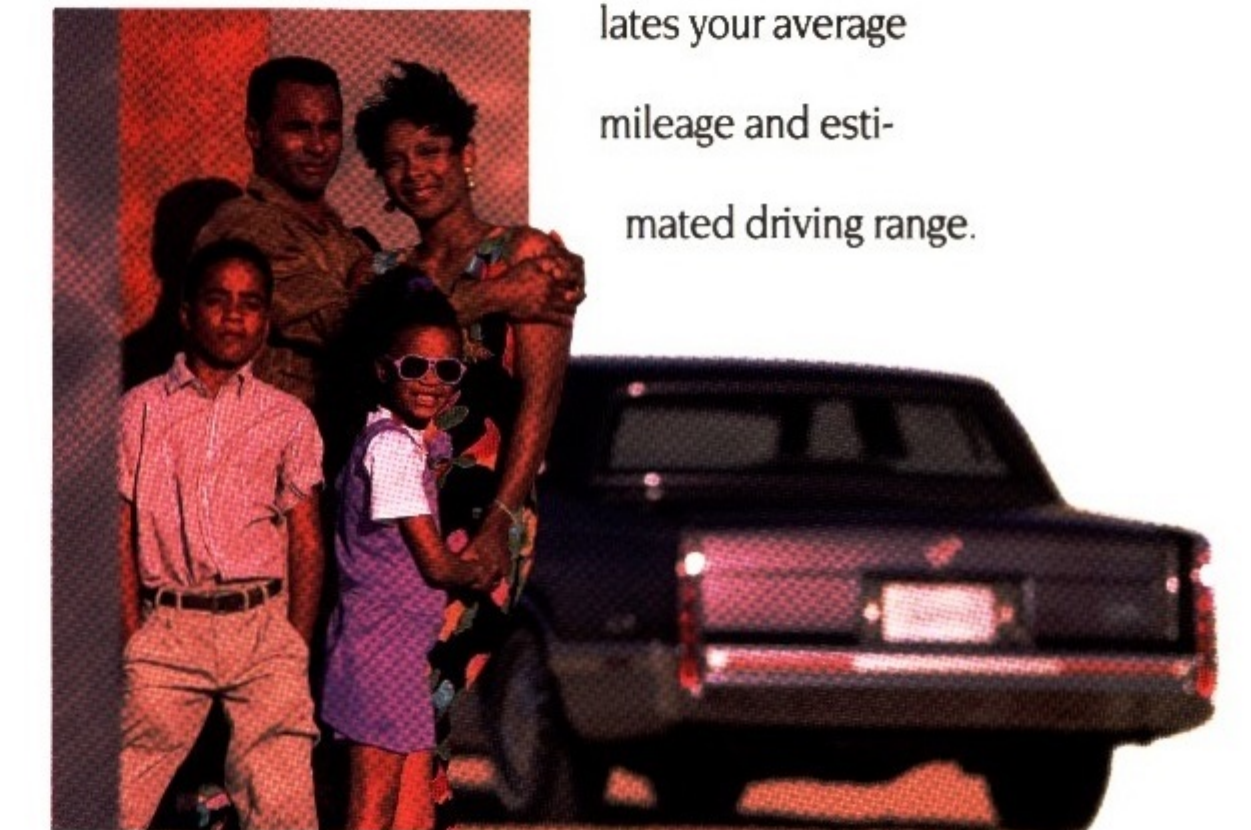

mileage and estimated driving range.

The standard Teves anti-lock braking system senses when wheels begin to lock during braking on a slippery surface or in a panic stop. Then, faster than humanly possible, it pulses the brakes to limit wheel lock-up. This helps you maintain maximum steering control as you brake.

De Ville's available Traction Control applies this same advanced anti-lock braking technology to



ELECTROCHROMIC INSIDE REARVIEW MIRROR.

acceleration. As you gain or maintain speed under 30 miles per hour, Traction Control takes over if either of the drive wheels is losing traction, limiting wheel spin until maximum available traction is restored.



DUAL-PLATINUM-TIPPED SPARK PLUGS HAVE A RECOMMENDED REPLACEMENT INTERVAL OVER THREE TIMES LONGER THAN REGULAR SPARK PLUGS—A FULL 100,000 MILES.

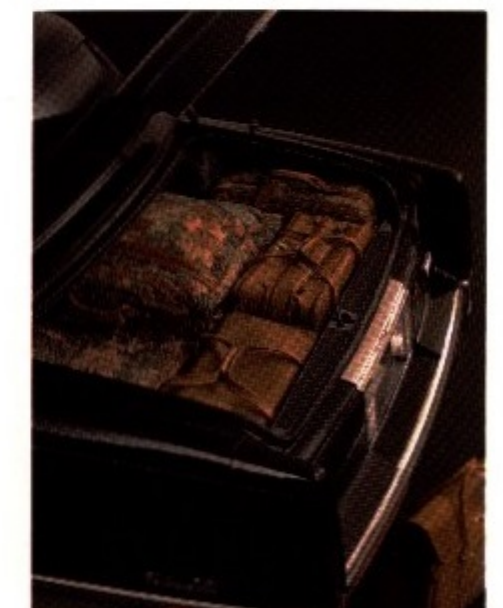

DE VILLE'S CAVERNOUS TRUNK LETS YOU STOW OVER 18 CUBIC FEET OF LUGGAGE, GOLF CLUBS AND MORE.

The Cadillac Touring Sedan indulges your passion for driving with sophisticated systems like Traction Control. Anti-lock braking. An electronically controlled V8 powertrain. Speed-Sensitive

Suspension specifically tuned for touring performance. All standard. But it also caters to your need for comfort with full-size, six-passenger spaciousness and luxurious amenities, including elec-

tronic climate control, power seat adjusters for both driver and front passengers and ultra-soft leather seating areas.



# T O U R I N G S E D A N

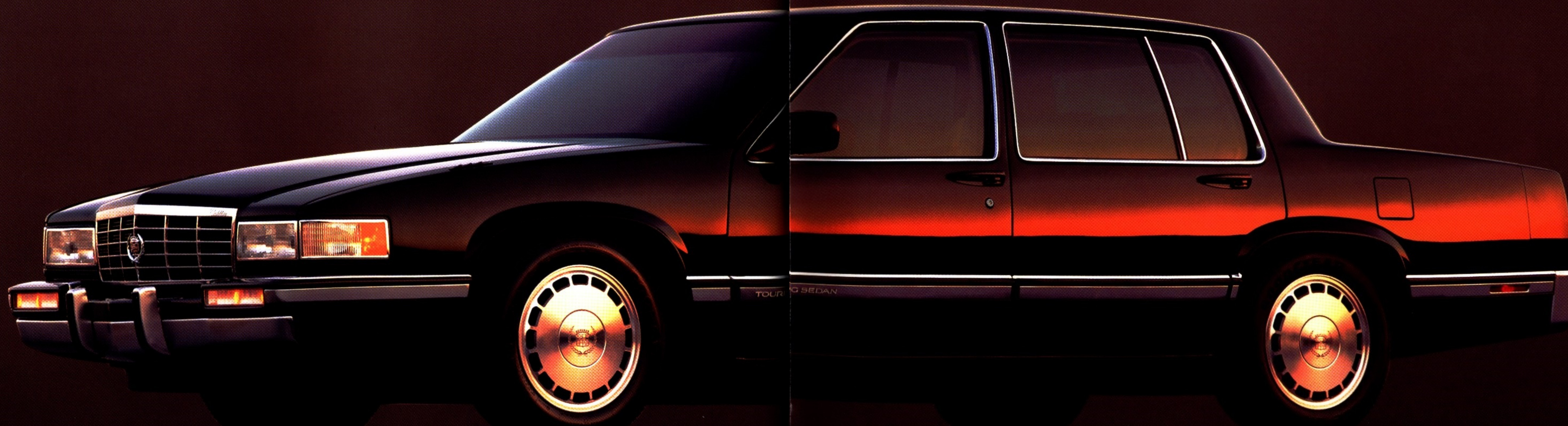

TOURING SEDAN SHOWN IN SABLE BLACK.

## A Fusion Of Performance And Comfort.

The Cadillac Touring Sedan affords you generous levels of performance and comfort without compromising either. Its inspiring performance stems from a responsive 4.9 liter V8 and four-speed electronically controlled transmission. A performance final drive ratio then helps transform this smooth torque into instantaneous acceleration. And now the same advanced anti-lock braking technology that helps bring your Touring Sedan to a controlled stop, will help it accelerate as well with new Traction Control. It minimizes unwanted wheel spin for maximum traction at speeds under 30 mph.



THIS ELEGANT CLOISONNÉ DECK LID EMBLEM IS HANDCASTED AND CRAFTED ONE AT A TIME.



TOURING SEDAN SHOWN WITH STANDARD BEECHWOOD LEATHER SEATING AREAS AND GENUINE AMERICAN WALNUT ACCENTS.



HAND GRIPS ENCOURAGE YOU TO EXERCISE THE TOURING SEDAN'S FAST-RATIO POWER STEERING.

The taut handling characteristics of the Cadillac Touring Sedan are the product of a speed-sensitive touring suspension that retunes itself as you drive. At lower speeds, it isolates you from road imperfections. At higher speeds, as you corner, or during brisk starts and stops, it stiffens for stable handling. Performance is also enhanced by fast-ratio power steering, aluminum-alloy wheels and 16"

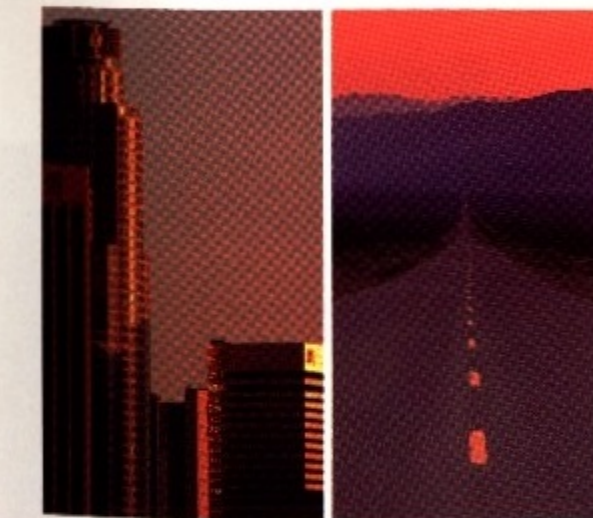

Goodyear Eagle GA tires.

The Cadillac Touring Sedan's expansive six-passenger interior also provides you with the level of comfort you have come to expect of Cadillac.

SPEED-SENSITIVE SUSPENSION AUTOMATICALLY ADJUSTS FOR IN-TOWN COMFORT AND HIGHWAY STABILITY.



STANDARD TRACTION CONTROL AUTOMATICALLY MINIMIZES WHEEL SLIP DURING ACCELERATION UNDER 30 MPH FOR EXTRAORDINARY ALL-WEATHER PERFORMANCE.



Spaciousness is unsurpassed among front-drive sedans sold in America. Seating areas are tailored with ultra-soft leather and stitched with elegant French seams. Driver and front-passenger seats feature an integral lumbar support, a patented split-frame design, plus power seat adjusters and recliners for superb comfort.

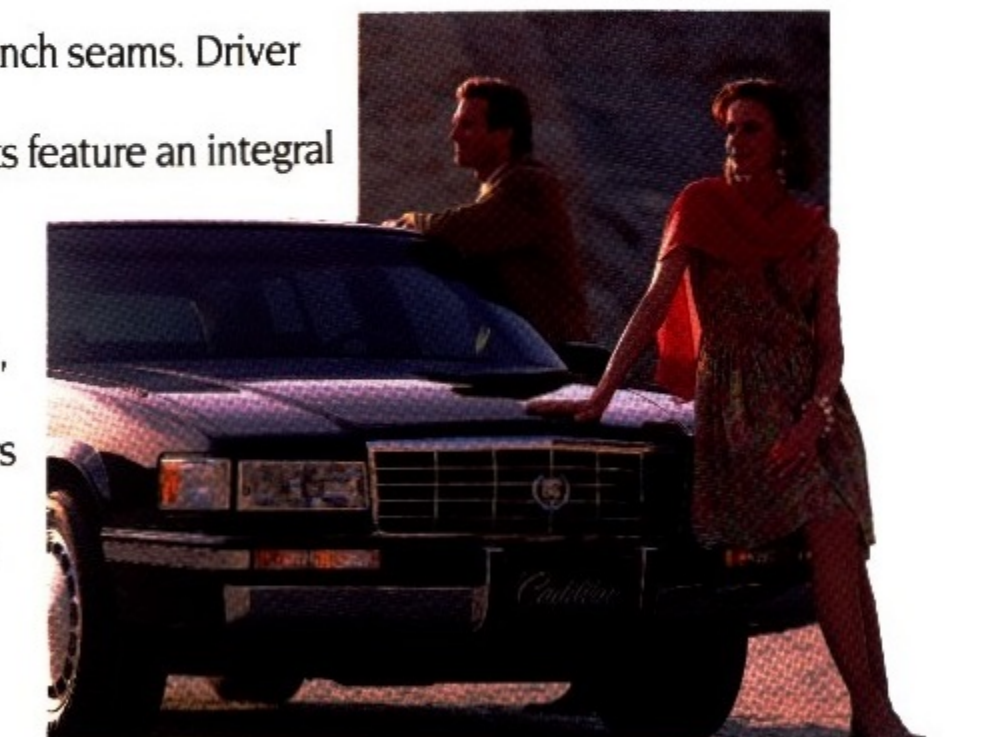





It is easy to understand why America is so comfortable with the classic Cadillac Brougham. Because as America's longest regular-production automobile, it affords you uncompromising, six-

passenger luxury with all the amenities. Plus a responsive V8 engine with throttle-body fuel injection. An available 7,000-pound towing capacity\* Standard anti-lock braking. Electronic

variable assist steering. Supplemented by the peace of mind of Cadillac ownership services, including 24-hour Cadillac Roadside Service®.



# B R O U G H A M



\*Trailer towing package—requires 5.7 liter V8 and includes 124-ampere alternator and trailer towing wiring harness—up to 7,000 lbs. towing capacity (includes passengers, cargo, trailer and equipment).

BROUGHAM D'ELEGANCE SHOWN IN BLACK SAPPHIRE.

## All The Comforts Of Brougham.

**B**rougham's full-size, six-passenger interior caters to your every comfort. Six-way power-adjusting front seats with power recliners leave you refreshed, even after long trips. Nearly five feet of shoulder room—front and rear—gives you room to relax. And the standard Delco Electronics AM stereo\*/FM stereo radio with cassette player provides dynamic sound reproduction.

You will also enjoy all the amenities you've come to expect from Brougham. The steering wheel, with a leather-wrapped rim, features Tilt-Wheel™ adjustable steering and telescoping functions. Adjustable rear-seat reading lamps provide added convenience. And Brougham features an advanced electronic climate control system.

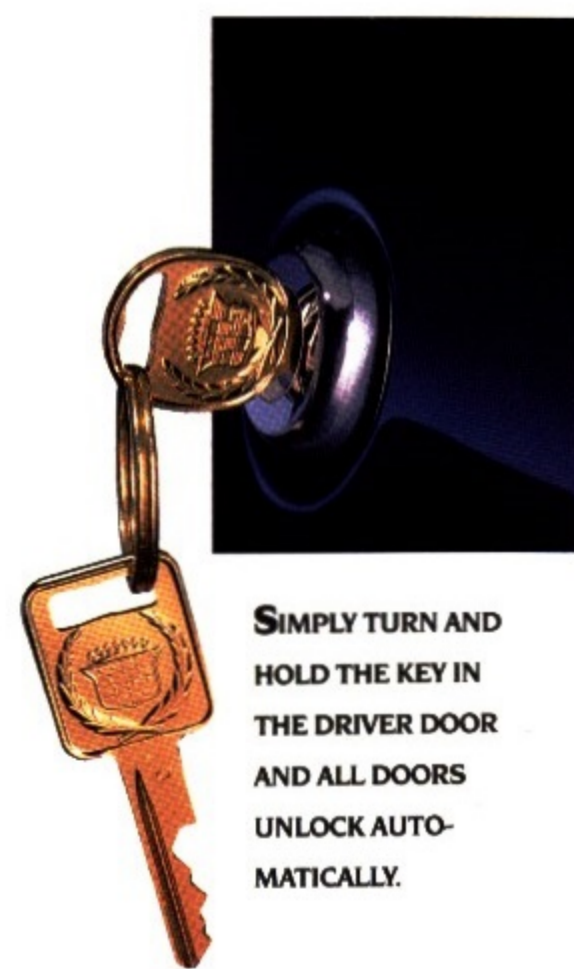

**SIMPLY TURN AND HOLD THE KEY IN THE DRIVER DOOR AND ALL DOORS UNLOCK AUTOMATICALLY.**



\*RECEIVES C-QUAM, STEREO BROADCASTS. MOST AM STEREO STATIONS ACROSS THE COUNTRY BROADCAST IN C-QUAM, BUT SOME DO NOT. CHECK WITH YOUR LOCAL STATIONS FOR COMPATIBILITY IN YOUR AREA.

**BROUGHAM D'ELEGANCE INTERIOR WITH AVAILABLE DARK BLUE LEATHER SEATING AREAS.**

The Cadillac Brougham and De Ville are the choice of premium coachbuilders when they set out to build custom limousines.

By virtue of unmistakable design. Timeless elegance. And a level of comfort befitting limousines of unparalleled distinction.



# L I M O U S I N E S

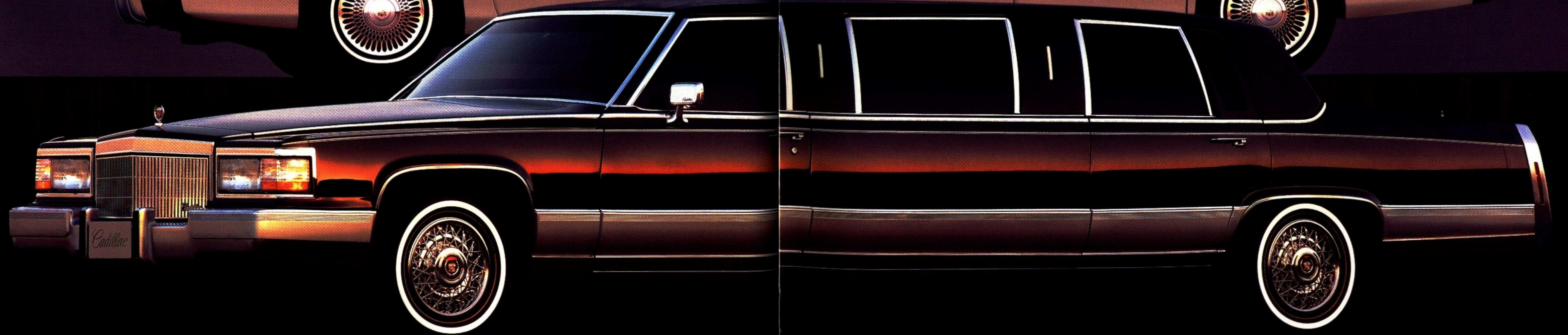
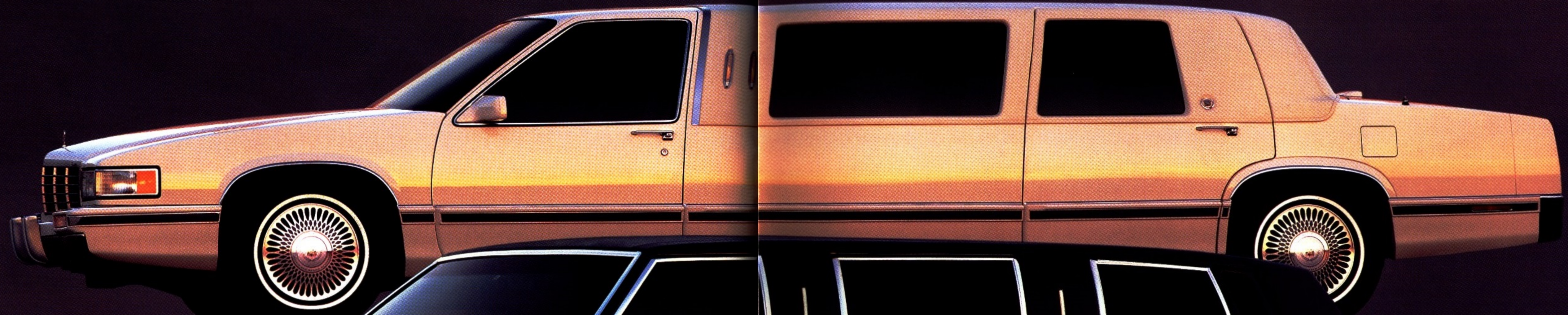

B  
R  
O  
U  
G  
H  
A  
M

ALL LIMOUSINES ARE AVAILABLE THROUGH MANUFACTURERS, RETAILERS AND ESTABLISHMENTS THAT ARE NOT PART OF THE CADILLAC MOTOR CAR DIVISION. AVAILABILITY, PRICE, AND QUALITY OF THESE ITEMS REST SOLELY WITH THE RESPECTIVE MANUFACTURERS AND THEIR SALES ORGANIZATIONS.

## America's Personal Limousine.



**B**rougham's classic styling is but one of its powerful distinctions. Beneath its rich clearcoat finish, a robust 5.0 liter fuel-injected V8 engine generates a responsive 170 horsepower and 255 lbs.-ft. of torque, in addition to impressive highway efficiency—EPA-estimated 25 miles per gallon highway.

An available 5.7 liter V8 engine provides 185 horsepower and 300 lbs.-ft. of torque for even greater passing power. And as part of the optional trailer towing package, it affords you impressive towing capacity—a full 7,000 pounds.\*

Even Brougham's spacious interior is designed for extended travel. In addition to its sheer size, standard amenities include electronic climate control, Soft-Ray<sub>®</sub> tinted glass to reduce glare, cruise control, power windows and automatic door locks, as well as power seat recliners.



**WHEN PROPERLY EQUIPPED WITH THE AVAILABLE 5.7 LITER V8, AMERICA'S LONGEST REGULAR PRODUCTION CAR ALSO PROVIDES IMPRESSIVE TOWING CAPACITY—A FULL 7,000 POUNDS WITH THE AVAILABLE TRAILER TOWING PACKAGE.\***

\*INCLUDES PASSENGERS, CARGO, TRAILER AND EQUIPMENT.

**BROUGHAM'S EASY-TO-READ DIGITAL INSTRUMENT PANEL PUTS CONTROLS AND CONVENIENCE FEATURES WITHIN COMFORTABLE REACH.**



**A**sophisticated Bosch II anti-lock braking system is standard. It automatically detects when wheels begin to slip during braking and pulses brakes faster than humanly possible—up to 15 times per second—to help you maintain greater steering control on virtually any road surface. Standard electronic variable assist steering automatically adjusts steering assistance proportionally to speed with maximum assistance for parking.



**BROUGHAM'S STANDARD ELECTRONIC VARIABLE ASSIST STEERING HELPS PROVIDE MAXIMUM ASSISTANCE FOR PARKING.**

**A**nd peace of mind is also standard. Because, like all Cadillacs, Brougham comes with an exceptional array of ownership services including 24-hour Cadillac Roadside Service<sub>®</sub> and the Cadillac 24-hour Consumer Relations Hotline.



**A MERE TOUCH OF THE POWER TRUNK LID RELEASE DISPLAYS 19.6 CUBIC FEET OF LUGGAGE SPACE.**

**SOPHISTICATED ANTI-LOCK BRAKES HELP YOU MAINTAIN STEERING CONTROL EVEN IN PANIC STOPS.**





## Premium Sound Systems

Audio systems in 1992 Cadillacs offer stunning realism: compact discs, Dolby<sup>®</sup> cassette tape, AM stereo\* and FM stereo radio. Either standard or available. With ergonomic controls so advanced operating them is uncomplicated.

### The Delco/Bose Audio Experience.

Cadillac was the first luxury automobile to offer the Delco/Bose audio experience. In 1992, Delco/Bose systems offer High Power Version II amplifier modules with up to 200 watts total power. Eldorado and Seville front-speaker enclosures are enlarged to reproduce deeper bass.

### Exceptional Audio Systems Standard.

From new radio/tape systems in Eldorado and Seville to the advanced yet uncomplicated system in Brougham, every standard radio/cassette tape system offers exceptional ergonomics and conveniences that enhance your enjoyment. Upgraded speakers in Eldorado and Seville improve stereo imaging, further refining the sound, while Eldorado Touring Coupe and Seville STS radios' new six-speaker system adds brilliance to reproduction.



**FLEETWOOD AND DE VILLE STANDARD PREMIUM AUDIO SYSTEM. SEEK/SCAN AM STEREO\*/FM STEREO RADIO AND FULL-FEATURED AUTO-REVERSE CASSETTE TAPE PLAYER. FIVE-BAND GRAPHIC EQUALIZER.**



**AVAILABLE DELCO/BOSE GOLD SERIES AUDIO SYSTEM FOR FLEETWOOD AND DE VILLE. SEEK/SCAN AM/FM STEREO RADIO PLUS DOLBY<sup>®</sup> B CASSETTE TAPE PLAYER. CUSTOM-EQUALIZED FOR EACH INTERIOR.**



**NEW ELDORADO AND SEVILLE STANDARD PREMIUM AUDIO SYSTEM WITH SEEK UP/DOWN, SCAN UP/DOWN TUNING FOR AM STEREO\*/FM STEREO RADIO. FULL-FEATURED DOLBY<sup>®</sup> B AUTO-REVERSE CASSETTE TAPE PLAYER. TWO EXTRA FRONT SPEAKERS IN ELDORADO TOURING COUPE, SEVILLE STS.**



**AVAILABLE FOR ELDORADO AND SEVILLE, THE DELCO/BOSE GOLD SERIES AUDIO SYSTEM SERVES UP BOTH COMPACT DISC AND FULL-FEATURED DOLBY<sup>®</sup> B CASSETTE TAPE ENTERTAINMENT ALONG WITH AM STEREO\*/FM STEREO RADIO. LARGER FRONT-SPEAKER ENCLOSURES REPRODUCE DEEPER BASS; CUSTOM-EQUALIZED FOR EACH INTERIOR.**



**DELCO/BOSE GOLD SERIES SOUND SYSTEM OFFERS COMPACT DISC REALISM, SEEK/SCAN AM STEREO\*/FM STEREO RADIO, AND IS CUSTOM-EQUALIZED FOR EACH INTERIOR. AVAILABLE FOR FLEETWOOD AND DE VILLE.**



**AVAILABLE BROUGHAM PREMIUM AUDIO SYSTEM INCLUDES BOTH COMPACT DISC AND FULL-FEATURED DOLBY<sup>®</sup> B AUTO-REVERSE CASSETTE TAPE PLAYER. SEEK UP/DOWN, SCAN UP/DOWN AM STEREO\*/FM STEREO RADIO, PLUS FIVE AUTOMATIC TONE-CONTROL PRESETS.**



**STANDARD BROUGHAM PREMIUM AUDIO SYSTEM INCLUDES FULL-FEATURED DOLBY<sup>®</sup> B AUTO-REVERSE CASSETTE TAPE PLAYER AND SEEK UP/DOWN, SCAN UP/DOWN AM STEREO\*/FM STEREO RADIO. FIVE AUTOMATIC TONE-CONTROL PRESETS.**

**ALLANTÉ'S STANDARD DELCO/BOSE GOLD SERIES PREMIUM AUDIO SYSTEM. 200 WATTS TOTAL POWER FOR GREATER CLARITY. INCLUDES BOTH COMPACT DISC AND FULL-FEATURED DOLBY<sup>®</sup> B CASSETTE TAPE PLAYER, AM STEREO\*/FM STEREO RADIO. CUSTOM-EQUALIZED FOR THE INTERIOR.**



## IMPORTANT WORDS ABOUT... THIS CATALOG

We have tried to make this catalog as comprehensive and factual as possible. We reserve the right, however, to make changes at any time, without notice, in prices, colors, materials, equipment specifications, models and availability. Since some information may have been updated since the time of printing, please check with your Cadillac dealer for complete details.

### ENGINES

Cadillacs are equipped with engines produced by different operating units of GM, its subsidiaries or suppliers to GM worldwide.

### ASSEMBLY

Cadillacs are assembled by different operating units of General Motors, its subsidiaries or suppliers to GM worldwide. Cadillacs incorporate thousands of components produced by different operating units of GM, its subsidiaries or suppliers to GM worldwide. We sometimes find it necessary to produce Cadillacs with different or differently sourced components than originally scheduled. All such components have been approved for use in Cadillacs and will provide the quality performance associated with the Cadillac name. Since some options may be unavailable when your vehicle is assembled, we suggest that you verify that your vehicle includes the equipment you ordered, or if there are changes, that they are acceptable to you.

### UPDATED SERVICE INFORMATION

Cadillac regularly sends its dealers useful service bulletins about Cadillac products. Cadillac monitors product performance in the field. We then prepare bulletins for servicing our products better. Now you can get these bulletins, too. Ask your dealer.

CADILLAC, the CADILLAC emblem, THE ONLY WAY TO TRAVEL IS CADILLAC STYLE, ALLANTÉ, FLEETWOOD, SEVILLE, SEDAN DE VILLE, COUPE DE VILLE, d'ELEGANCE, ELDORADO, CADILLAC ROADSIDE SERVICE, and the GM emblem are registered trademarks of the General Motors Corporation. BROUGHAM is a trademark of General Motors Corporation. GMAC is a registered trademark of the General Motors Acceptance Corporation. Litho in U.S.A. 8/91 ©1991 GM CORP. All Rights Reserved. Buckle Up America!

To get ordering information, call toll-free 1-800-551-4123.

### FINANCING OR LEASING. IT'S AS EASY AS GMAC.

Financing is done right in the showroom. Terms are tailored to suit your personal needs. You can choose your monthly payment date.

### CORROSION PROTECTION

Cadillacs are designed and built to resist corrosion. All body sheet-metal components are warranted against rust-through corrosion for 6 years/100,000 miles. Allanté is covered for 7 years/100,000 miles. There is no deductible for rust-through repairs. Application of additional rust-inhibiting materials is not required under the corrosion coverage and none is recommended.

### WARRANTY

The GM 4-year/50,000-mile Gold Key Bumper to Bumper limited warranty covers repairs for any new Cadillac, including labor and parts, to correct any defects in material or workmanship occurring during the warranty period. The complete vehicle will be covered for 4 years or 50,000 miles, whichever comes first (except tires, which are covered by their manufacturer, adjustments, normal maintenance items and battery, which is covered by its own 4-year/50,000-mile prorated warranty). The Cadillac Allanté is backed by the Allanté Assurance Plan—4-year/50,000-mile bumper-to-bumper warranty, including free towing and a portfolio of other services, and 7 years/100,000 miles on powertrain, major assembly components and rust-through protection. There is no deductible on any Cadillac warranty. See your Cadillac dealer for terms of these limited warranties.



CADILLAC MOTOR CAR DIVISION

