

ALL-NEW SUPER DUTY®

2011



ford.ca



TESTED TOUGH

to **OUTWORK** all the rest.



F-350 LARIAT Crew Cab 4x4 in Golden Bronze/Pale Adobe Two-Tone with available equipment.

Already proven – beyond any other.

The all-new Super Duty® endured more torture testing than any Ford Truck before it – including over 16 million cumulative kilometres on the **MOST TESTED POWER STROKE® DIESEL ENGINE EVER**. A world-class team put it through a groundbreaking battery of computer simulations, lab and real-world tests – running it for **THOUSANDS OF HOURS ON END**. In extreme conditions. All to confirm that this truck is far more than the sum of its parts.

It's built to be the best, bringing you 2 all-new Ford-built engines with the **BEST DIESEL AND GAS FUEL EFFICIENCY** of any truck in the class¹. Plus lots of other capabilities and features only Ford can deliver.

BEST IN THE CLASS

- Max. Horsepower and Torque
- Max. Conventional Towing: 16,000 lbs. (7,258 kg)²
- Max. 5th-Wheel Towing: 24,400 lbs. (11,068 kg)²
- Max. Payload: 6,520 lbs. (2,957 kg)²
- Fuel Efficiency: Diesel and Gas

CLASS EXCLUSIVES

- Live-Drive Power TakeOff (PTO) Provision³
- 5th-Wheel/Gooseneck Trailer Tow Prep Package³
- LCD Productivity Screen³
- Standard Safety Canopy® System
- Ford Work Solutions™³
- Tailgate Step³

¹Class is Full-Size Pickups over 8,500 lbs. (3,855 kg) GVWR. Based on Ford drive-cycle tests of comparably equipped 2011 Ford and 2010 competitive models. Test procedure follows the guidelines of the Society of Automotive Engineers' (SAE) Standard J1321. ²When properly equipped. 24,400 lbs. (11,068 kg) on F-450 Pickup. 6,520 lbs. (2,957 kg) on F-350 DRW Regular Cab 4x2. ³Optional.

2011
ALL-NEW SUPER DUTY®

ford.ca



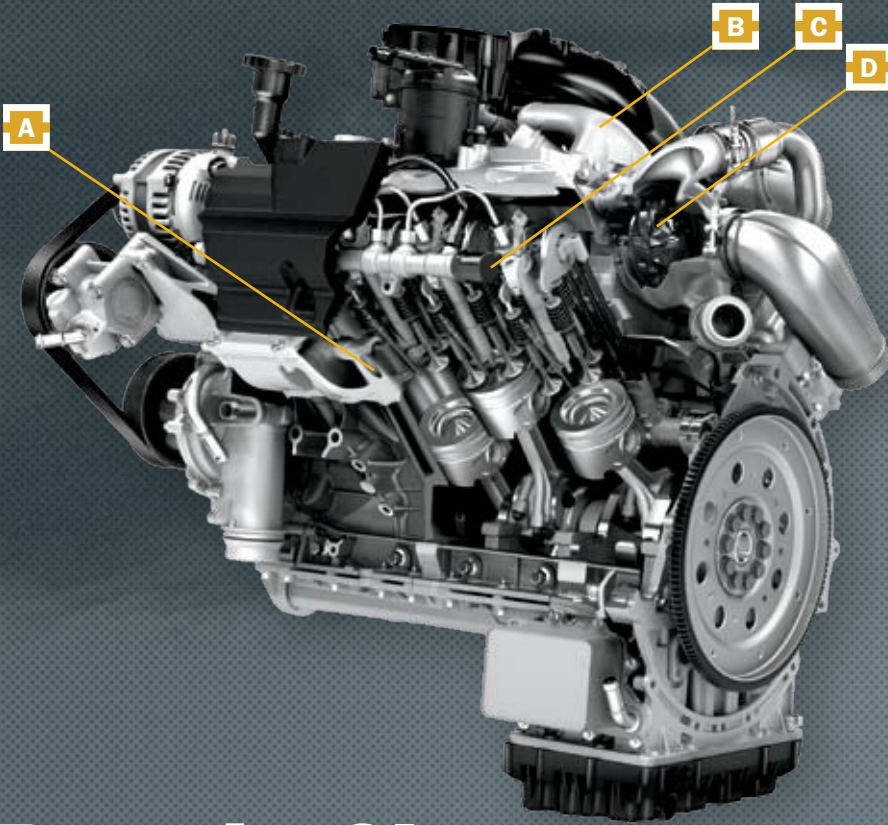

Best-in-Class FUEL EFFICIENCY

and **735** other
TORQUED-UP REASONS TO
GO DIESEL.

6.7L V8 DIESEL PERFORMANCE

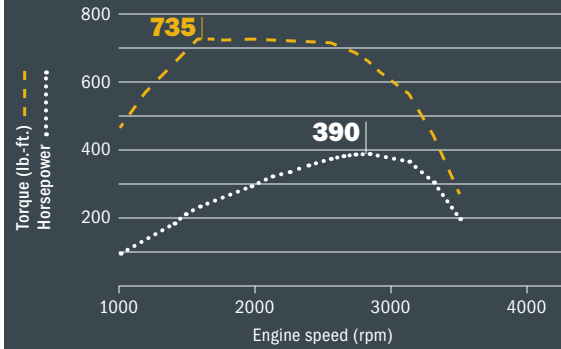

- A ALUMINUM CYLINDER HEADS** with precision dual water jackets reduce weight and improve cooling.
- B CLASS-EXCLUSIVE INBOARD EXHAUST AND OUTBOARD AIR INDUCTION** architecture helps reduce turbo lag.
- C NEW COMMON-RAIL FUEL INJECTION SYSTEM**, operating at nearly 30,000 psi, uses precise control to provide optimum power, efficiency and noise, vibration and harshness (NVH) performance.
- D CLASS-EXCLUSIVE SINGLE-SEQUENTIAL TURBOCHARGER** uses the compact, efficient design of a dual-sided compressor wheel to help deliver maximum power quickly.
- ENGINE-EXHAUST BRAKING** helps the all-new Ford TorqShift® 6-speed SelectShift Automatic® transmission provide better grade descent control with less brake and transmission wear and tear. Fully integrated with tow/haul mode, it provides increased engine braking at higher engine speeds.
- EXCLUSIVE LIVE-DRIVE POWER TAKEOFF (PTO) PROVISION**, available on the 6.7L diesel, is the only one in the class that uses an output gear linked directly to the engine crankshaft to power upfits anytime the engine's running, whether you're in motion or at a stop.

Designed, engineered and built by Ford, this all-new diesel helps Super Duty® deliver up to an **18% IMPROVEMENT IN FUEL EFFICIENCY** over the previous model, making it the best in its class.¹ It also gives you best-in-class **390 HORSEPOWER** and **735 LB.-FT. OF TORQUE**. That's a game-changing combination. The new **INTELLIGENT OIL-LIFE MONITOR™** tracks oil temperature, filter regeneration cycles, engine idle hours and distance travelled, then alerts you when it's time to change the oil. And even though this **B20-CAPABLE** engine is new to the lineup, it's already proven itself in over 16 million kilometres of cumulative testing. It's the **MOST TESTED POWER STROKE DIESEL ENGINE EVER**.

¹Based on Ford drive-cycle tests of comparably equipped 2011 Ford and 2010 competitive models.



6.2L V8 GAS PERFORMANCE

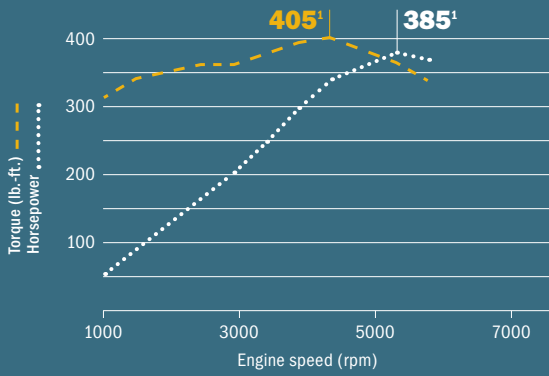

Certified to SAE J1349.

¹385 hp and 405 lb.-ft. of torque under 10,000 lbs. (4,536 kg) GVWR.
316 hp and 397 lb.-ft. of torque over 10,000 lbs. (4,536 kg) GVWR.

- A DUAL-EQUAL VARIABLE CAM TIMING** phases the intake- and exhaust-valve opening and closing events simultaneously to optimize fuel efficiency, low-end torque and peak horsepower.
- B 2 SPARK PLUGS PER CYLINDER** burn the fuel-air mixture more efficiently and help increase engine torque.
- C STIFF SOHC VALVETRAIN** with roller-rocker shafts and optimized camshaft-lift profiles produces significant low-rpm torque and enables an intake- and exhaust-port layout that leads to better breathing.
- D CYLINDER BLOCK DESIGN** is specifically engineered to optimize the efficiency of crankcase airflow, resulting in improved torque at higher engine speeds.
- NEW SELECTSHIFT AUTOMATIC**[®] transmission offers control and convenience, featuring a full manual mode that locks the torque converter and holds your chosen gear, plus a progressive range select mode that locks out upper gears when the truck is heavily loaded or when towing on grades.

BEST GAS

**fuel efficiency,
power and torque
IN THE CLASS.**

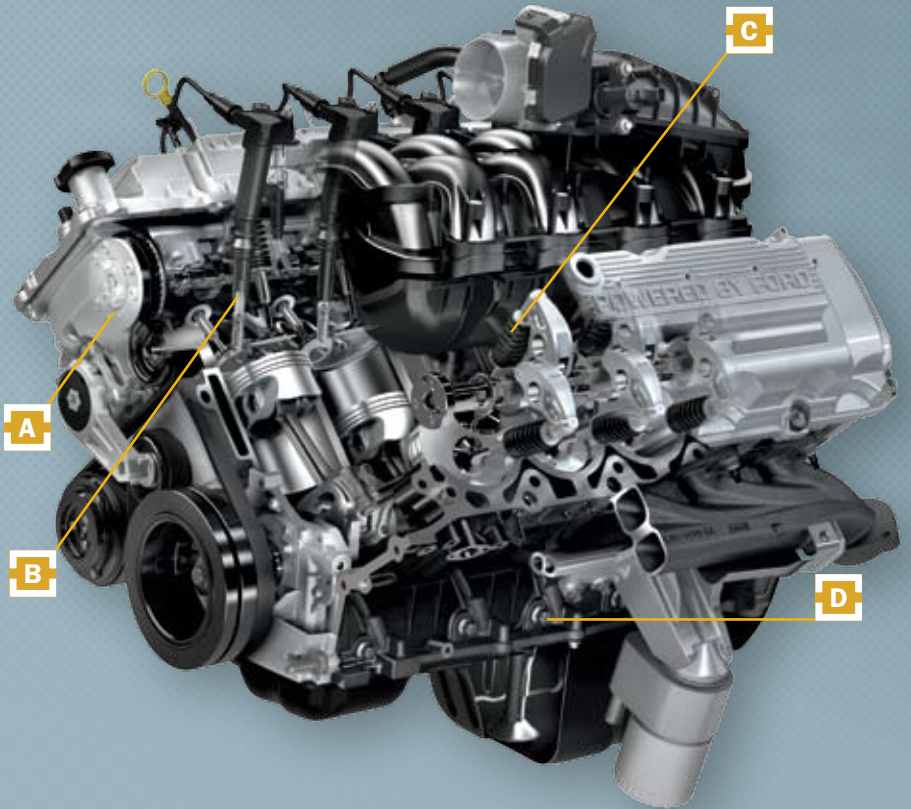

All-New Ford 6.2L V8 Gas Engine.

As the new standard engine, this free-breathing Ford-built machine helps Super Duty[®] achieve up to **15% BETTER FUEL EFFICIENCY** than the previous base engine, making it the best in its class.² It also delivers best-in-class **385 HORSEPOWER** and **405 LB.-FT.¹ OF TORQUE**. The new design features large valves and a large-bore, shorter-stroke approach – proven technologies inspired by Ford racing – that help improve its breathing.

And you can rest assured this all-new **E85-CAPABLE** engine is ready to get to work. The Ford powertrain team designed, engineered, built and torture-tested it themselves.

²Based on Ford drive-cycle tests of comparably equipped 2011 Ford and 2010 competitive models. Test procedure follows the guidelines of the Society of Automotive Engineers' (SAE) Standard J1321.

2011
ALL-NEW SUPER DUTY[®]

ford.ca





F-450 LARIAT Crew Cab 4x4 in White Platinum Tri-coat/Pale Adobe Two-Tone with available equipment.

PULLS IT OFF

like **NO ONE ELSE** can.

Super Duty® reigns supreme with best-in-class towing capabilities,¹ class-exclusive features and systems like standard new trailer sway control for **ULTIMATE TOWING CONFIDENCE**. A single touch of the brake pedal in tow/haul mode activates the available integrated diesel engine-exhaust braking to help improve control with less wear and tear on the brakes and transmission.

BEST-IN-CLASS MAX. TOWING

**Conventional: 16,000 LBS.
(7,258 KG)**

**5th Wheel: 24,400 LBS.
(11,068 KG)**

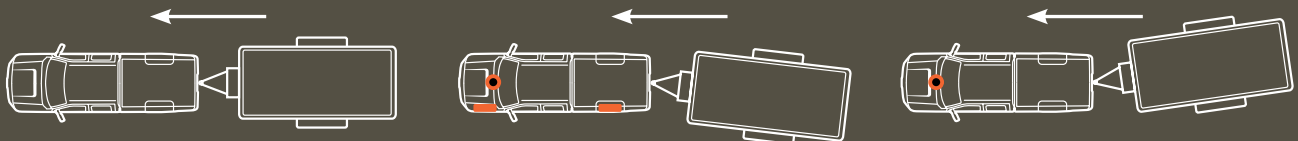

NEW STANDARD TRAILER SWAY CONTROL² uses a yaw motion sensor to monitor the motions of your truck and detect trailer sway. When trailer sway is detected, the system can automatically react by selectively braking, helping you **MAINTAIN CONTROL** of both the truck and the trailer.

FACTORY-INSTALLED 5TH-WHEEL/GOOSENECK TRAILER TOW PREP PACKAGE offers you the strength of an under-the-bed frame crossmember and maintains a flat cargo bed floor. This patent-pending system is compatible with the Ford Custom Accessory 5th-Wheel and Gooseneck Hitch Kits by Reese.[®]

CLASS-EXCLUSIVE POWERSCOPE™ TRAILER TOW MIRRORS adjust, fold and telescope at the touch of a switch; this option includes integrated clearance lights and turn signals, plus heated glass with manually adjustable blind spot mirrors.

¹When properly equipped. ²Remember that even advanced technology cannot overcome the laws of physics. It's always possible to lose control of a vehicle due to inappropriate driver input for the conditions.

2011 ALL-NEW SUPER DUTY®

ford.ca



MOST EFFICIENT MOBILE OFFICE in its class.

All-New Interior With Class-Leading Storage Solutions.

REDESIGNED SEATS include exclusive Ford “active comfort” contours, new materials and a standard lumbar support for the driver, plus they’re **HEATED AND COOLED** up front on LARIAT. With its collection of available technologies and **BEST-IN-CLASS INTERIOR STORAGE** possibilities – including the **MOST LOCKABLE STORAGE** (up to 68 litres [2.4 cu. ft.]), and the most power access available in the class (up to 6 locations) – Super Duty® is built to help you take care of business. An available **RAPID-HEAT SUPPLEMENTAL CAB HEATER**¹ helps raise the cabin temp so you and your crew can stay active even when it’s downright frigid outside.

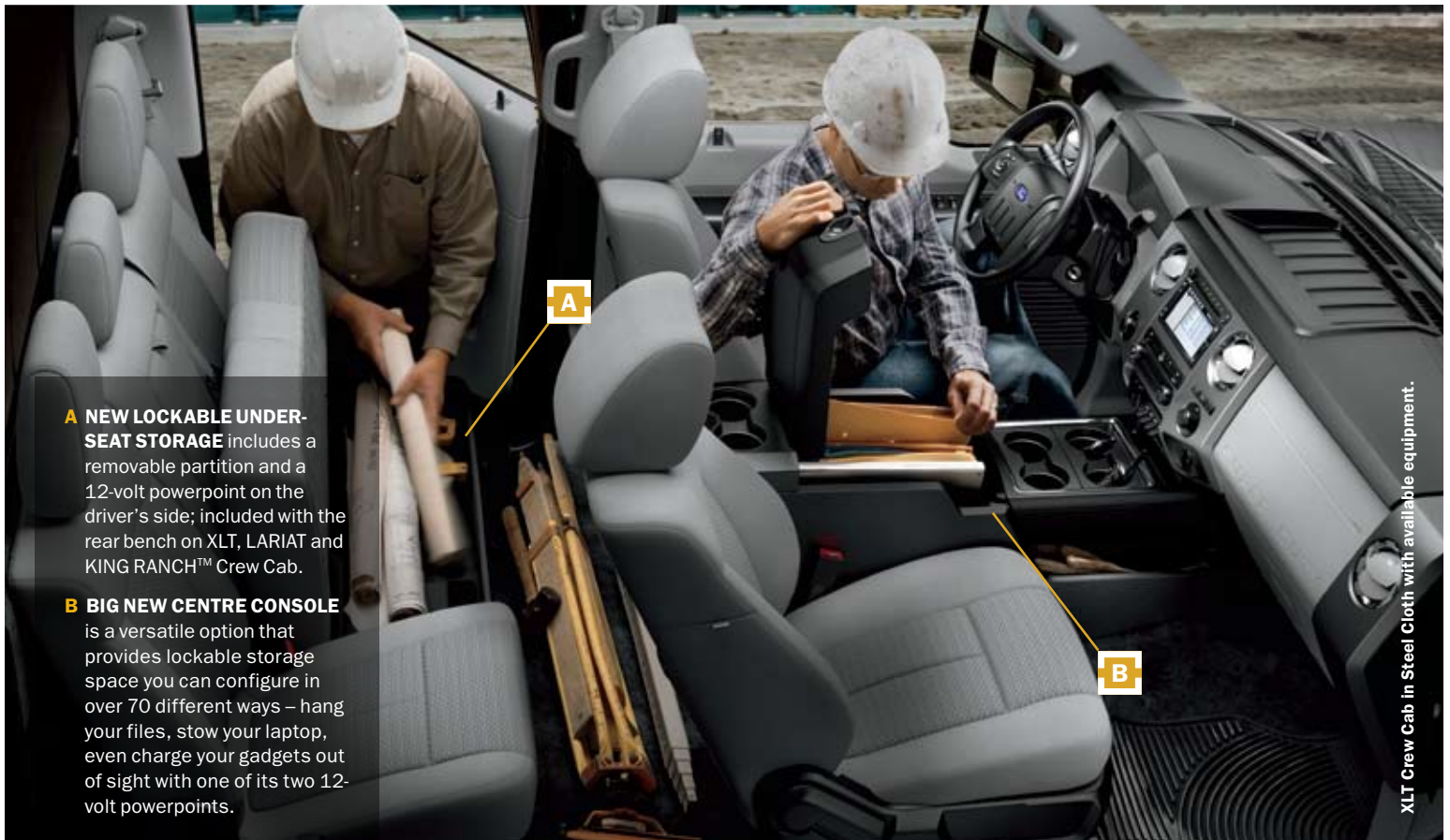

A NEW LOCKABLE UNDER-SEAT STORAGE includes a removable partition and a 12-volt powerpoint on the driver’s side; included with the rear bench on XLT, LARIAT and KING RANCH™ Crew Cab.

B BIG NEW CENTRE CONSOLE is a versatile option that provides lockable storage space you can configure in over 70 different ways – hang your files, stow your laptop, even charge your gadgets out of sight with one of its two 12-volt powerpoints.

XLT Crew Cab in Steel Cloth with available equipment.



ALL-NEW LCD PRODUCTIVITY SCREEN, an available option in the redesigned gauge cluster, features easy-to-use menus to help you track fuel usage, explore unique truck applications and even make towing decisions. You can also use it to limit your truck’s top speed with the available class-exclusive **MyKey™** owner controls feature.



NEW 110-VOLT POWER INVERTER is located on the back of the available centre console.

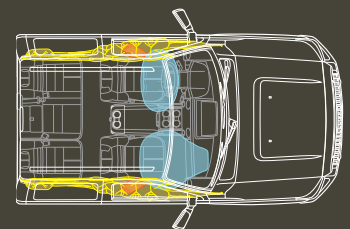

6 AIRBAGS NOW STANDARD, including new front-seat side airbags and the Safety Canopy® System with its rollover sensor and side-curtain airbags designed for enhanced protection in certain side-impact and rollover collisions.



¹Optional on models equipped with the 6.7L Power Stroke® V8 Turbo Diesel engine.

A DUAL ALTERNATORS WITH 357-AMP RATING are optional with the all-new 6.7L turbo diesel engine; they provide 11.5% more peak amperage than the previous generation.

B COIL-SPRING FRONT SUSPENSION is part of a heavy-duty, independent twin-I-beam setup on 4x2s and a rugged twin-coil monobeam setup on 4x4s.

C NEW STEERING SYSTEM on F-250 and F-350 4x2s is symmetrical left to right for more precise response with better on-centre steering and control.

D SOLID FRONT AXLE WITH MANUAL LOCKING HUBS is a tried-and-true 4x4 design that delivers excellent articulation, ground clearance and reliability.

E ALL-NEW TRANSFER CASE SKID PLATE utilizes high-strength steel for better off-road protection with less weight; part of the optional FX4 OFF-ROAD Package.

F STANDARD 4-WHEEL ANTI-LOCK BRAKE SYSTEM (ABS) uses vented rotors and dual-piston calipers for consistent stops, even with the heaviest loads.

G RIDE AND HANDLING IMPROVEMENTS include optimized rear leaf springs and spring rates, plus adjustments to the internal valving in all pickup shock absorbers, offering a more refined ride experience with best-in-class towing and payload capability.

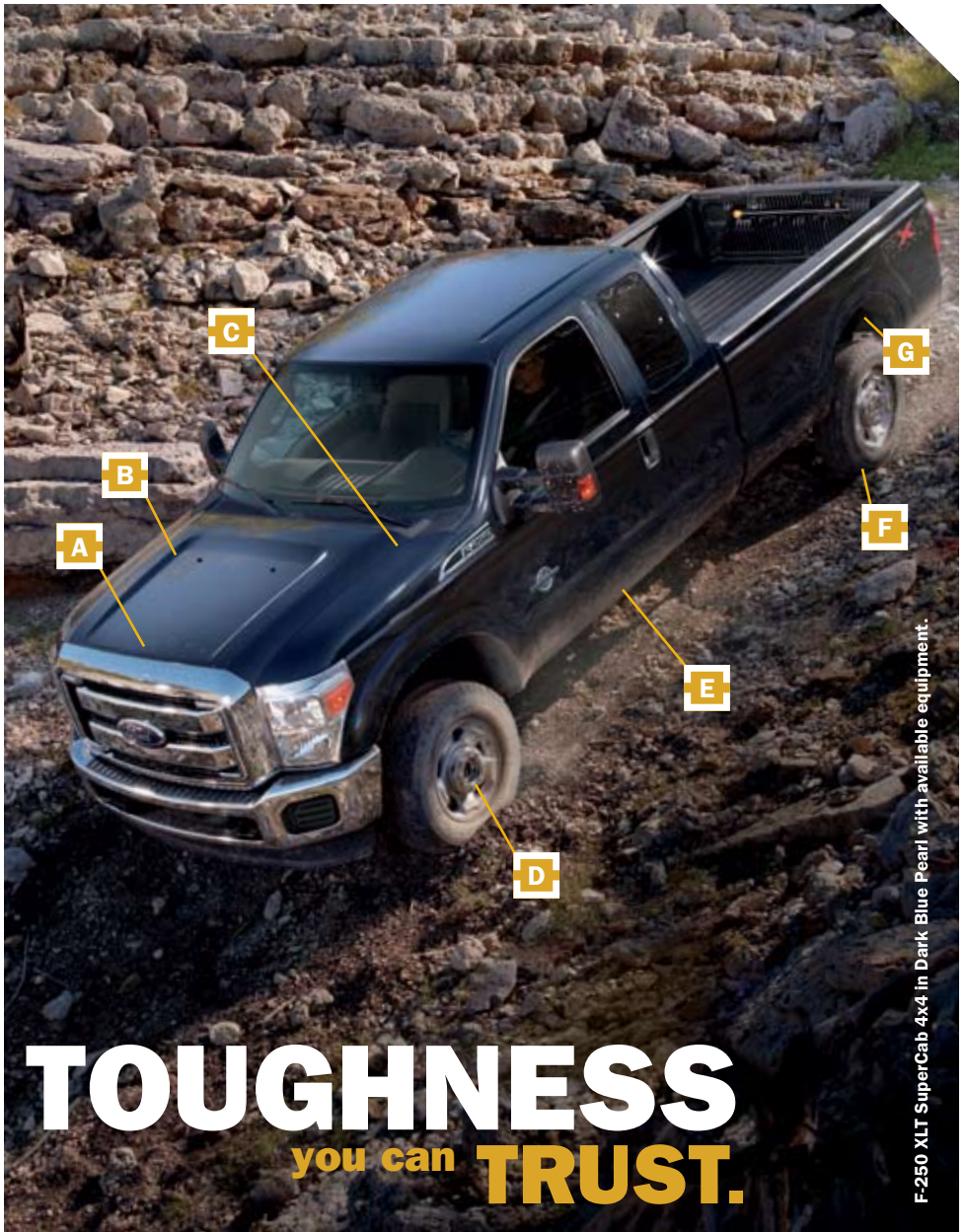

TOUGHNESS

you can **TRUST.**

F-250 XLT SuperCab 4x4 in Dark Blue Pearl with available equipment.



An available **NEW ELECTRONIC-LOCKING REAR DIFFERENTIAL** uses a true mechanical dog-clutch mechanism to lock both rear axle shafts together so they turn at the same speed for maximum traction.

Enhanced Off-Road Capability.

You can rest assured the all-new 2011 Super Duty® is built on a solid foundation, one that's designed to meet most any challenge and conquer most any terrain. At the push of a button, available **NEW HILL DESCENT CONTROL™¹** helps maintain the speed of the truck on steep declines. It allows you to concentrate on driving rather than modulating the brakes, increasing your off-road confidence.

¹SRW models with optional FX4 OFF-ROAD Package only.



Monitor pitch angle, bank angle and wheel direction with the **CLASS-EXCLUSIVE OFF-ROAD DISPLAY** in the available new LCD Productivity Screen.

2011 ALL-NEW SUPER DUTY®

ford.ca



STRENGTH

you can **COUNT ON.**

F-250 XL Regular Cab 4x2 in Oxford White with available equipment.

A

B

**BEST-IN-CLASS MAX. PAYLOAD:
6,520 LBS. (2,957 KG)¹**

Hardworking people need a hardworking truck. The all-new 2011 Super Duty[®] gives its all to every job with **BEST-IN-CLASS PAYLOAD** capability of up to 6,520 lbs. (2,957 kg),¹ plus equipment to help you load, access and manage that payload. When your reputation's on the line, your truck's got to deliver.

A CLASS-EXCLUSIVE TAILGATE STEP option stows right in the tailgate; includes flip-up grab bar and skid-resistant step.

B REMOVABLE TAILGATE includes a key lock. Tailgate assist with torsion spring enables easy operation.

An optional **CLASS-EXCLUSIVE STOWABLE BED EXTENDER** lets you haul with the tailgate down or corral smaller loads with it up. When not in use, the extender stows conveniently to the sides – out of your way.



NEW ADVANCETRAC[®] WITH RSC[®] (ROLL STABILITY CONTROL[™]) is the only brake-based electronic stability control system to utilize a roll-rate sensor, monitoring the vehicle's roll motion at least 100 times per second. It works with the Anti-Lock Brake System (ABS), traction control and yaw control to automatically determine when and how to apply the brakes and modify engine power to help keep all 4 wheels firmly planted.²

¹When properly equipped. F-350 DRW Regular Cab 4x2. ²SRW models only. Engine-only traction control on DRW models. Remember that even advanced technology cannot overcome the laws of physics. It's always possible to lose control of a vehicle due to inappropriate driver input for the conditions.

UPFITTER SWITCHES can operate high-power relays for heavy-duty accessories. Integrated with the instrument panel, they're optional on all models.



2011 ALL-NEW SUPER DUTY[®]

ford.ca





XLT In Adobe Cloth with Ford Work Solutions In-Dash Computer, available wireless printer and other available equipment.

TECHNOLOGIES that give your team the ADVANTAGE.



The available voice-activated **NAVIGATION SYSTEM** with **SIRIUS® SATELLITE RADIO** maps routes anywhere in Canada⁴ and guides you with audible instructions. It includes a 6.5-in. LCD touch screen, 8 speakers with a subwoofer, and nearly 10 GB of storage space for your photos and music (up to 2,400 songs). You can even use it to watch DVDs when in park. SIRIUS Satellite Radio comes with a 6-month prepaid subscription, so you can surf up to 120 channels including 100% commercial-free music, plus the best sports, news, talk and entertainment, all across Canada.⁵



The award-winning **FORD SYNC®** with 911 Assist™ uses your paired Bluetooth®-enabled mobile phone and digital media player or USB drive to deliver hands-free calling and play your digital music.⁶ SYNC. Say the word.

Ford Work Solutions include Ford Licensed Accessories. See your Ford of Canada Dealer for limited warranty details.

¹Available on XL and XLT models only. Some features are unavailable while driving. Not available with SYNC or SIRIUS Satellite Radio. See your Ford of Canada Dealer for details. ²Service fee required. ³Tool Link system cannot read tagged items stored in metal tool boxes. ⁴See your Ford of Canada Dealer for mapping details. ⁵See your Ford of Canada Dealer or contact SIRIUS at 1-888-539-7474 for more information. ⁶Driving while distracted can result in loss of vehicle control. Only use mobile phones and other devices, even with voice commands, when it is safe to do so. The vehicle's electrical system (including the battery), the wireless service provider's signal and a connected mobile phone must all be available and operating for 911 Assist to function properly. These systems may become damaged in a crash. The paired mobile phone must be connected to SYNC, and the 911 Assist feature enabled, in order for 911 to be dialed.



Cutting-Edge Mobile Office.

Only the toughest name in trucks could assemble this all-star lineup of **SMART TOOLS** for your tough jobs. At the heart of it all is the available **INTERNET-CAPABLE IN-DASH COMPUTER** with Garmin® navigation, hands-free calling, and a convenient touch screen with wireless keyboard. From spreadsheets to surfing the Web, it helps tackle your workload and ease your day!¹

Take advantage of the available **CREW CHIEF™** fleet management system¹ from Microlise™ to track your vehicles and keep them in shape with key diagnostic/informational maintenance reports.² This beneficial system can be accessed from the Ford Work Solutions™ in-dash computer, or any computer connected to the Internet.

Like to save time and money on the job? The available **TOOL LINK™** system can help!¹ Using RFID (radio frequency ID) technology from DeWALT®, Tool Link helps track your tools before and after each job.³



CABLE LOCK SYSTEM by Master Lock® makes it easy to secure your gear. The optional 10-ft. vinyl-coated, retractable, braided-steel cable spools out of a rugged case mounted right in your cargo box.

2011
ALL-NEW SUPER DUTY®

ford.ca



MODELS & STANDARD FEATURES

F-250

MAXIMUM CAPABILITIES

5th-Wheel Towing: 7,484 kg (16,500 lbs.)
Conventional Towing: 6,350 kg
(14,000 lbs.)
Payload: 1,837 kg (4,050 lbs.)
GCWR: 10,660 kg (23,500 lbs.)
GVWR: 4,536 kg (10,000 lbs.)
Front GAWR: 2,381 kg (5,250 lbs.) (4x2);
2,722 kg (6,000 lbs.) (4x4)

EQUIPMENT CONFIGURATIONS

Engines: 6.2L Gas V8 FFV, 6.7L Power Stroke® V8
Drivelines: 4x2 or 4x4 ■ Single Rear Wheel Only
Bodies: Regular Cab, SuperCab, Crew Cab ■ 6.75-ft. Box, 8-ft. Box
Trim Series: XL, XLT, LARIAT, KING RANCH™
Appearance Packages: XL Décor, Chrome

MECHANICAL

Battery saver
Brakes — Vacuum-boost (SRW gas and F-250 SRW diesel)
Brakes — Hydro-boost (F-350 SRW diesel and DRW)
Electronic-locking rear axle (SRW only)
Engine block heater
Engine-only traction control (EOTC) (DRW only)
Fail-Safe Engine Cooling System (gas engines)
Fuel tank — 98-litre capacity (F-250/F-350 137-in., 142-in. and 156-in. WB with diesel engine)
Fuel tank — 132-litre capacity (gas engine only)
Fuel tank — 142-litre capacity (F-250/F-350 158-in. and 172-in. WB with diesel engine, and F-450)
Limited-slip rear axle (DRW only)
Power steering
Quick-release tailgate with tailgate assist
SecuriLock® Passive Anti-Theft Engine Immobilizer System
Spare tire/wheel/jack — Conventional with underframe carrier (crank-down type)
Stabilizer bar — Front
Stabilizer bar — Rear (DRW only)
Stainless steel exhaust system (major components)
Stationary elevated idle control (SEIC)¹
Steering damper
Styleside box
Tire Pressure Monitoring System (SRW only; excludes spare)
Trailer hitch receiver — 5,670 kg (12,500 lb.) (2-in.)
Built Ford Tough®
Trailer hitch receiver — 6,350 kg (14,000 lb.) (2-in.)
Built Ford Tough (SRW diesel with 156-in., 158-in. or 172-in. WB only) (late availability)
Trailer hitch receiver — 7,257 kg (16,000 lb.) (2.5-in.)
Built Ford Tough (DRW only)
Trailer sway control

INTERIOR

Assist and ride handles
Coat hooks — 1 (Regular Cab); 2 in rear of cab (SuperCab and Crew Cab)
Dome light (front and rear with Crew Cab)
Flip-open rear quarter windows (SuperCab)
Overhead console with garage door opener storage and sunglasses storage (SuperCab and Crew Cab)
Powerpoints — 2 on instrument panel
Steering wheel — Telescoping
Instrumentation — Engine-hour meter, speedometer, tachometer,

F-350

MAXIMUM CAPABILITIES

5th-Wheel Towing: 9,798 kg (21,600 lbs.)
Conventional Towing: 7,258 kg
(16,000 lbs.)
Payload: 2,957 kg (6,520 lbs.)
GCWR: 13,154 kg (29,000 lbs.)
GVWR: 5,897 kg (13,000 lbs.)
Front GAWR: 2,381 kg (5,250 lbs.) (4x2);
2,722 kg (6,000 lbs.) (4x4)

EQUIPMENT CONFIGURATIONS

Engines: 6.2L Gas V8 FFV, 6.7L Power Stroke V8
Drivelines: 4x2 or 4x4 ■ Single Rear Wheel or Dual Rear Wheel
Bodies: Regular Cab, SuperCab, Crew Cab ■ 6.75-ft. Box, 8-ft. Box
Trim Series: XL, XLT, LARIAT, KING RANCH
Appearance Packages: XL Décor, Chrome

F-450

MAXIMUM CAPABILITIES

5th-Wheel Towing: 11,068 kg
(24,400 lbs.)
Conventional Towing: 7,258 kg
(16,000 lbs.)
Payload: 2,232 kg (4,920 lbs.)
GCWR: 14,969 kg (33,000 lbs.)
GVWR: 5,919 kg (13,050 lbs.)
Front GAWR: 2,722 kg (6,000 lbs.)

EQUIPMENT CONFIGURATIONS

Engine: 6.7L Power Stroke V8 Only
Driveline: 4x4 ■ Dual Rear Wheel Only
Body: Crew Cab 8-ft. Box Only
Trim Series: XL, XLT, LARIAT, KING RANCH
Appearance Packages: XL Décor, Chrome

trip odometer, oil pressure, coolant temperature, transmission temperature gauge, air filter minder (diesel only), fuel gauge, urea gauge (diesel only), indicator lights, turbo boost (diesel only), engine-idle meter (6.2L only), SelectShift display, distance-to-empty, average fuel economy, warning messages and Ice Blue™ Lighting

EXTERIOR

“3-Blink” lane change signal
Bumpers — Front step and rear step
Cargo box — Partitionable and stackable
Cargo box lamp — Integrated with centre high-mounted stop lamp
Cargo box rail and tailgate top mouldings
Cargo box stake pockets
Cargo tie-down hooks — 4 in 6.75-ft. box; 6 in 8-ft. box
Daytime running lamps
Headlamps — Dual-beam jewel-effect
Solar-tinted glass
Tow hooks — 2 in front
Trailer tow — 7-/4-pin connector and trailer brake wiring kit (in-cab, no controller)
Underhood service lamp
Windshield wipers — Intermittent

SAFETY & SECURITY

4-wheel power disc brakes with Anti-Lock Brake System (ABS)
Airbags² — Driver and right-front-passenger front
Airbags² — Front-seat side
Airbags² — Safety Canopy® System with rollover sensor and roll-fold side-curtain airbags
Alert chimes — Headlamps-on, key-in-ignition and door ajar
AdvanceTrac® with RSC® (Roll Stability Control™) (SRW only)
Belt-Minder™ front safety belt reminder
Brake/shift interlock
Child-safety-seat top tether anchors (Regular Cab front passenger and all rear-seat positions)
Fuel pump inertia shutoff switch
Height-adjustable safety belts — Front-outboard positions
Locking tailgate
Passenger airbag deactivation switch (Regular Cab, SuperCab)
Safety belt energy-management retractors — Front-outboard positions
Side-intrusion door beams
SOS Post-Crash Alert System™³

Microsoft is a registered trademark of Microsoft Corporation.
The Bluetooth word mark is a trademark of the Bluetooth SIG, Inc.
Windows is a registered trademark of Microsoft Corporation.
DeWALT is a registered trademark of The Black & Decker Corporation.
Garmin is a registered trademark of Garmin Ltd.
King Ranch is a trademark of King Ranch, Inc.
Master Lock is a registered trademark of Master Lock Company LLC.
Microlise is a trademark of Microlise Limited.
¹Final-stage manufacturer must supply control switches.
²Always wear your safety belt and follow airbag warning label instructions.
³SOS hardware may become damaged or the battery may lose power in a crash, which could prevent operation. Not all crashes will activate an airbag or safety belt pretensioner.

2011 ALL-NEW SUPER DUTY®

ford.ca



STANDARD FEATURES



XL

Includes all standard features, plus:

MECHANICAL

6.2L SOHC 2-valve Gas V8 flex-fuel E85-capable engine (n/a on F-450)

6.7L Power Stroke® V8 Turbo Diesel B20-capable engine (standard on F-450)

TorqShift® Heavy-Duty 6-speed SelectShift Automatic® transmission

17-in. wheels

LT245/75R17 all-season BSW tires

Integrated trailer brake controller (DRW)

Manual 4-Wheel-Drive System with manual locking hubs (4x4 models only)

SEATING

Front seat – HD vinyl 40/20/40 split with armrest, cupholders and storage

Manual lumbar support – Driver only

Rear seat – 60/40 split flip-up seat (SuperCab only)

Rear seat – 60/40 split flip-up/fold-down rear bench seat with outboard and centre head restraints (Crew Cab only)

INTERIOR

Air conditioning – Manual

AM/FM stereo with digital clock and 2 speakers

Floor covering – Black vinyl

Manual door locks and windows

Mirror – Manual day/night rearview

Multifunction message centre – Includes distance to empty, average fuel efficiency, system check, language selection, and 3-button steering wheel-mounted controls

Steering column – Tilt/telescoping

Steering wheel – Black urethane

Visors with passenger mirror

EXTERIOR

6-in. Black angular step bars (DRW only)

Bumpers – Black-painted with grained top cover

Door handles – Black

Grille – Black bar-style

Mirrors – Manually telescoping trailer tow with 2-way fold and manual glass

Mouldings – Black box top and tailgate top



XLT

Includes all XL features, plus:

MECHANICAL

Electronic shift-on-the-fly (ESOF) 4-Wheel-Drive System with auto/manual locking hubs (4x4 only)

SEATING

Front seat – 40/20/40 split with centre under-seat lockable storage with 12v powerpoint and centre armrest with cupholders and storage

Rear seat – 60/40 split flip-up/fold-down seat with bag hooks, dual integrated cupholders and tray, outboard head restraints, centre head restraint and lockable under-seat partitioned storage with 12v powerpoint (Crew Cab only)

INTERIOR

Accessory delay for power features

AM/FM stereo/single-CD player with MP3 capability, digital clock and 4 speakers

Auxiliary audio input jack

Cruise control

Floor covering – Colour-coordinated carpet

Floor mats – Colour-coordinated carpet

MyKey™ owner controls feature

Power door locks

Power windows with one-touch-down driver's side window feature

SIRIUS Satellite Radio with 6-month prepaid subscription

Visors with driver and passenger mirrors

EXTERIOR

Anti-theft perimeter alarm

Bumpers – Chrome with grained top cover

Grille – Chrome bar-style

Mirrors – Manually telescoping trailer tow with 2-way fold, power/heated glass, heated manual blind spot mirrors, and integrated clearance lamps and turn signals

Privacy glass (rear doors and rear window)

Remote Keyless Entry System with 2 integrated key transmitter remotes



LARIAT

Includes all XLT features, plus:

MECHANICAL

18-in. premium cast-aluminum wheels (SRW) LT275/65R18 all-season BSW tires (SRW)

Integrated trailer brake controller (SRW)

SEATING

Front seat – Leather-trimmed 40/20/40 split with centre under-seat lockable storage with 12v powerpoint and centre armrest with cupholders and storage

Power 10-way driver and front-passenger seats

Heated/cooled seats – Driver and front-passenger

INTERIOR

Air conditioning – Dual-zone electronic automatic temperature control

Driver-configurable enhanced information centre with 4.2-in. LCD Productivity Screen – Includes gauge setup, trip computer, fuel efficiency and towing/off-road applications, SelectShift controls, halo lighting, daytime illumination, and 5-button steering wheel-mounted switch

Ford SYNC® voice-activated, in-vehicle communications and entertainment system

Memory Group – Includes memory feature on power trailer tow mirrors, power 10-way driver's seat, and adjustable pedals

Mirror – Auto-dimming rearview with compass

Premium Sound System AM/FM stereo/single-CD player with MP3 capability, digital clock and 8 speakers with subwoofer (n/a with Navigation System)

Steering wheel – Colour-coordinated leather-wrapped with secondary audio controls

Universal garage door opener

Visors with covered illuminated driver and passenger mirrors

Woodgrain-style instrument panel accents

EXTERIOR

6-in. angular Black step bar

Autolamp with rainlamp feature

Door handles – Body-colour

Fog lamps

Mirrors – PowerScope™ power-telescoping/-folding trailer tow with power/heated glass, heated manual blind spot mirrors, and integrated clearance lamps and turn signals

Reverse Sensing System

SecuriCode™ keyless entry keypad

Sliding rear window – Power with privacy glass



KING RANCH™

Includes all LARIAT features, plus:

SEATING

Front seat – Chaparral leather-trimmed seats and flow-thru centre console with lockable storage, two 12-volt powerpoints and a 110-volt power inverter

INTERIOR

Floor mats – Colour-coordinated carpet with KING RANCH logo

Steering wheel – Chaparral leather-wrapped with secondary audio controls

Unique woodgrain-style instrument panel accents

EXTERIOR

Bodyside mouldings – Body-colour (SRW only)

Bumpers – Accent-colour monochromatic
Cab steps – Illuminated accent-colour with bright insert

Grille – Body-colour surround w/chrome bars and accent-colour insert

Mirrors – PowerScope power-telescoping/-folding trailer tow with memory, power/heated glass, heated manual blind spot mirrors, integrated clearance lamps and turn signals with body-colour mirror caps

Mouldings – Accent-colour box top and tailgate

Two-tone paint – Lower-accent

Wheel-lip mouldings – Accent-colour (SRW)

XL



17-in. Argent-Painted Steel
Standard on F-250/F-350 SRW



17-in. Argent-Painted Steel
Standard on F-350 DRW



17-in. Forged, Polished-Aluminum
Standard on F-450 DRW



18-in. Argent-Painted Steel
Optional on F-350 SRW



XL Regular Cab in Steel HD Vinyl with available equipment.



F-250 XL Regular Cab 4x2 in Oxford White with available equipment.

2011 ALL-NEW SUPER DUTY®

ford.ca



XL OPTIONAL FEATURES

MECHANICAL

- 6.7L Power Stroke® V8 Turbo Diesel B20-capable engine (standard on F-450)
- Electronic shift-on-the-fly (ESOF) 4-Wheel-Drive System with auto/manual locking hubs (4x4 models only)
- 18-in. argent-painted steel wheels – 4 (F-350 SRW)
- LT245/75R17 all-terrain BSW tires – 5 (F-250, F-350 DRW and F-450)
- LT265/70R17 all-terrain OWL tires – 4 (F-250/F-350 SRW)
- LT275/65R18 all-season BSW tires – 5 (F-350 SRW)
- LT275/70R18E all-terrain BSW tires – 4 (F-350 SRW)
- 5th-Wheel/Gooseneck Trailer Tow Prep Package – Includes 1 under-bed frame crossmember, 5 pickup bed 5th-wheel/gooseneck attachment points and close-out plugs, and an integrated 7-pin connector on the driver's side pickup bed wall
- Alternator – Single, extra-heavy-duty 200-amp (diesel engine only)
- Alternators – Dual, 357-amp total (diesel engine only)
- Higher-ratio rear axle (gas engine only)
- Integrated trailer brake controller (standard on F-350 DRW/F-450)
- Power Code™ Remote Start System (requires Power Equipment Group; Fleet only)
- Power takeoff (PTO) provision – Includes transmission-mounted live drive and stationary modes (diesel engine only)
- Reverse Sensing System (n/a with pickup box delete)

SEATING

- Front seat – 40/mini-console/40 bucket seats (cloth only)

INTERIOR

- Accessory delay for power features¹
- Ford SYNC® voice-activated, in-vehicle communication and entertainment system (requires cruise control and CD player)
- MyKey™ owner controls feature (included with CD player)
- Power door locks¹
- Power windows with one-touch-down driver's side window feature¹
- AM/FM stereo/single-CD player with MP3 capability, digital clock, 4 speakers and auxiliary audio input jack
- Cruise control
- Rapid-heat supplemental cab heater (requires diesel engine and alternator upgrade)
- Upfitter switches (4) – Located on instrument panel
- Instrument cluster – Black with black gauges

EXTERIOR

- Bumpers – Chrome with grained top cover²
- Mirrors – Black manual fold-away sideview (F-250/F-350 only; not available with 6.7L diesel engine)
- Mirrors – Manually telescoping trailer tow with 2-way fold, power/heated glass, heated manual blind spot mirrors, and integrated clearance lamps and turn signals (requires Power Equipment Group)
- Skid plates – Transfer case and fuel tank (4x4 only)
- Sliding rear window – Manual with privacy glass (Fleet only)
- Cab steps – 6-in. angular Black-moulded (standard on DRW)
- Pickup box delete (F-250/F-350 only; long wheelbase only)
- Roof clearance lamps (standard on DRW)
- Tailgate step – Includes step, tailgate assist and grab bar

FORD WORK SOLUTIONS™

- In-dash Windows® CE computer with touch screen (restrictions apply)
- Cable Lock System by Master Lock®
- Crew Chief™ (n/a with SYNC or in-dash computer)
- Tool Link™ (requires in-dash computer; restrictions apply)

PACKAGES

- XL Décor Package – Includes chrome bumpers with grained top cover and bright chrome hub covers and centre ornaments (SRW only)
- 4,490-kg (9,900-lb.) GVWR Package (SRW only; F-250 requires diesel engine)
- Camper Package (restrictions apply)
- FX4 OFF-ROAD Package
- Heavy-Service Front Suspension Package
- Heavy Service Package for Pickup Box Delete (F-250 only)
- Power Equipment Group (Fleet only)
- Snow Plow Prep Package (4x4 only; restrictions apply)

¹Included as a part of Power Equipment Group.
²Included as a part of XL Décor Package.
 Power Code is a trademark of Code Systems, Inc.

EXTERIOR



INTERIOR



Steel Cloth
Optional

Colours are representative only. See your Ford of Canada Dealer for actual paint/trim options.

EXTERIOR COLOURS

INTERIOR COLOURS

Oxford White	■	●
Vermillion Red	■	●
Dark Blue Pearl Metallic	■	●
Forest Green Metallic	■	●
Ingot Silver Metallic	■	●
Sterling Gray Metallic	■	●
Tuxedo Black Metallic	■	●
Pale Adobe Metallic	■	●

INTERIORS: ■ Steel HD Vinyl ● Steel Cloth

SEATING, BOX AND CAB CONFIGURATIONS

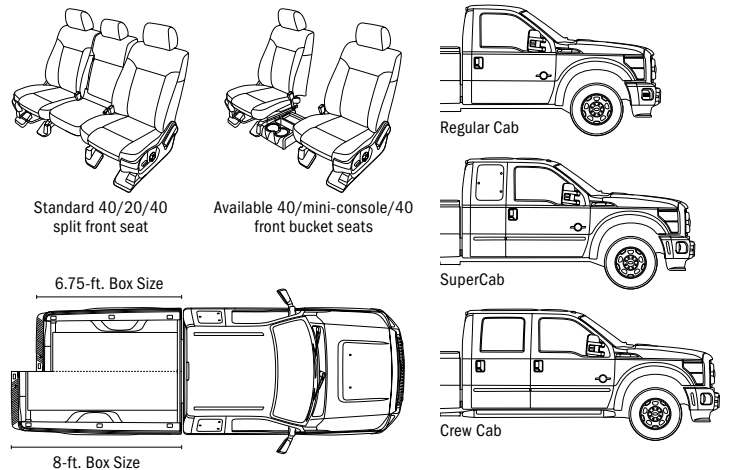

XLT



17-in. 5-Spoke Cast-Aluminum
Standard on F-250/F-350 SRW



17-in. Argent-Painted Steel
Standard on F-350 DRW



17-in. Forged, Polished-Aluminum
Standard on F-450 DRW/Optional on F-350 DRW



18-in. Cast-Aluminum
Optional on F-250/F-350 SRW



20-in. Premium Cast-Aluminum
Optional on F-250/F-350 SRW



XLT Crew Cab in Steel Cloth with flow-thru centre console and available equipment.



F-250 XLT SuperCab 4x4 in Tuxedo Black with available equipment.

2011 ALL-NEW SUPER DUTY®

ford.ca



XLT OPTIONAL FEATURES

MECHANICAL

6.7L Power Stroke® V8 Turbo Diesel B20-capable engine (standard on F-450)
 17-in. forged, polished-aluminum wheels – 4 (F-350 DRW)
 18-in. cast-aluminum wheels – 4 (F-250/F-350 SRW)
 20-in. premium cast-aluminum wheels – 4 (SRW 4x4 diesel engine only; SuperCab and Crew Cab only)
 LT245/75R17 all-terrain BSW tires – 5 (F-350 DRW/F-450)
 LT245/75R17 all-terrain OWL tires – 4 (F-350 DRW/F-450)
 LT265/70R17 all-terrain OWL tires – 4 (F-250/F-350 SRW)
 LT275/65R18 all-season BSW tires – 5 (F-250/F-350 SRW 4x2)
 LT275/70R18 all-terrain BSW tires – 4 (F-250/F-350 SRW 4x4)
 LT275/70R18 all-terrain OWL tires – 4 (F-250/F-350 SRW 4x4)
 LT275/65R20 all-terrain OWL tires – 4 (SRW 4x4; SuperCab and Crew Cab only)
 5th-Wheel/Gooseneck Trailer Tow Prep Package – Includes 1 under-bed frame crossmember, 5 pickup bed 5th-wheel/gooseneck attachment points and close-out plugs, and an integrated 7-pin connector on the driver's side pickup bed wall (requires 8-ft. box; n/a with stowable bed extender)
 Alternator – Single, extra-heavy-duty 200-amp (diesel engine only)
 Alternators – Dual, 357-amp total (diesel engine only)
 Higher-ratio rear axle (gas engine only)
 Integrated trailer brake controller (standard on F-350 DRW/F-450)
 Power Code™ Remote Start System
 Power takeoff (PTO) provision – Includes transmission-mounted live drive and stationary modes (diesel engine only)
 Reverse Sensing System (n/a with pickup box delete)

SEATING

6-way power driver seat
 Front seat – Cloth 40/console/40 bucket seats and flow-thru console with lockable storage, two 12v powerpoints and a 110v power inverter (SuperCab and Crew Cab only)

INTERIOR

Carpet delete
 Ford SYNC® voice-activated, in-vehicle communications and entertainment system
 Floor mats – Black all-weather (deletes carpeted floor mats)
 Power-adjustable pedals
 Rapid-heat supplemental cab heater (requires diesel engine and alternator upgrade)
 Rear view camera (requires power seats)
 Upfitter switches (4) – Located on instrument panel

EXTERIOR

Autolamp with rainlamp feature (included with Advanced Security Group)
 Fog lamps (included with XTR Package)
 SecuriCode™ keyless entry keypad (included with Advanced Security Group)
 Skid plates – Transfer case and fuel tank (4x4 only)
 Bodyside mouldings – Body-colour (SRW only)
 Cab steps – 6-in. angular Black-moulded (standard on DRW)
 Cab steps – 5-in. chrome tubular (SuperCab and Crew Cab only)
 Mirrors – PowerScope™ power-telescoping/-folding trailer tow with power/heated glass, heated manual blind spot mirrors, and integrated clearance lamps and turn signals
 Pickup box delete (F-250/F-350 only; requires long wheelbase and n/a with rear view camera)
 Roof clearance lamps (standard on DRW)
 Sliding rear window – Manual with privacy glass (Regular Cab only)
 Sliding rear window – Power with privacy glass (SuperCab and Crew Cab only)
 Stowable bed extender (F-250/F-350 SRW only)
 Tailgate step – Includes step, tailgate assist and grab bar

FORD WORK SOLUTIONS™

In-dash Windows® CE computer with touch screen (restrictions apply)
 Cable Lock System by Master Lock®
 Crew Chief™ (n/a with SYNC or in-dash computer)
 Tool Link™ (requires in-dash computer; restrictions apply)

PACKAGES

XTR Package – Includes chrome exhaust tip, tow hooks, mirror caps and pickup bed tie-down hooks; Advanced Security Group; PowerScope trailer tow mirrors; 6-in. angular Chrome steps; fog lamps; and 18-in. cast-aluminum wheels (SRW SuperCab and Crew Cab only)
 XTR Plus Package – Includes Multiplex Instrumentation Pack with 4.2-in. LCD display, 6-way power driver and passenger seats, power sliding rear window with privacy glass, SYNC, Reverse Sensing System and power-adjustable pedals (requires XTR Package; SRW SuperCab and Crew Cab only)
 4,490-kg (9,900-lb.) GVWR Package (SRW only; F-250 requires diesel engine)
 Advanced Security Group
 Camper Package (restrictions apply)
 FX4 OFF-ROAD Package
 Heavy-Service Front Suspension Package
 Heavy Service Package for Pickup Box Delete (F-250 only)
 Snow Plow Prep Package

EXTERIOR



INTERIOR



EXTERIOR COLOURS

EXTERIOR COLOURS	INTERIOR COLOURS
Oxford White	● ●
Vermillion Red	● ●
Dark Blue Pearl Metallic	● ●
Forest Green Metallic	● ●
Ingot Silver Metallic	● ●
Sterling Gray Metallic	● ●
Tuxedo Black Metallic	● ●
Royal Red Metallic	● ●
Golden Bronze Metallic	● ●
Pale Adobe Metallic	● ●

INTERIORS: ● Adobe Cloth ● Steel Cloth

Colours are representative only. See your Ford of Canada Dealer for actual paint/trim options.

SEATING, BOX AND CAB CONFIGURATIONS

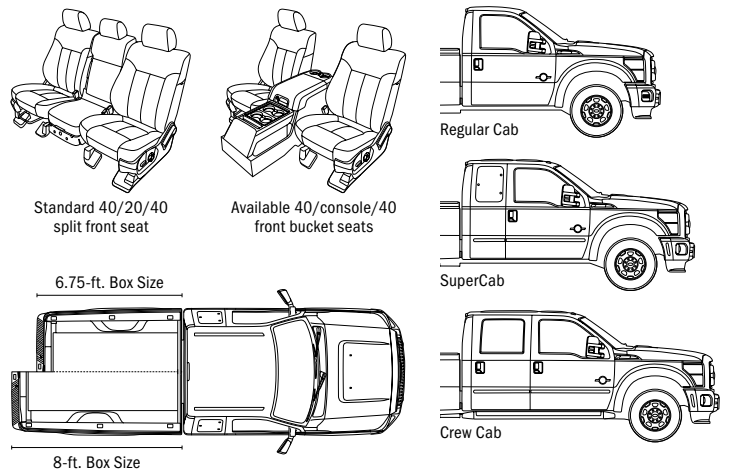

2011 ALL-NEW SUPER DUTY®

ford.ca



LARIAT



F-450 LARIAT in White Platinum Tri-coat/Pale Adobe Two-Tone with available equipment.



17-in. Forged, Polished-Aluminum
Standard on F-350 DRW/F-450 DRW



18-in. Bright-Machined, Cast-Aluminum
Standard on F-250/F-350 SRW



20-in. Premium Cast-Aluminum
Optional on F-250/F-350 SRW



LARIAT Crew Cab in Black Two-Tone Leather with available equipment.

2011 ALL-NEW SUPER DUTY®

ford.ca



LARIAT OPTIONAL FEATURES

MECHANICAL

- 6.7L Power Stroke® V8 Turbo Diesel B20-capable engine (standard on F-450)
- 20-in. premium cast-aluminum wheels – 4 (F-250/F-350 SRW 4x4 diesel engine only)
- LT245/75R17 all-terrain BSW tires – 5 (F-350 DRW/F-450)
- LT245/75R17 all-terrain OWL tires – 4 (F-350 DRW/F-450)
- LT275/70R18E all-terrain OWL tires – 4 (F-250/F-350 SRW 4x4)
- LT275/65R20 all-terrain OWL tires – 4 (F-250/F-350 SRW 4x4)
- 5th-Wheel/Gooseneck Trailer Tow Prep Package – Includes 1 under-bed frame crossmember, 5 pickup bed 5th-wheel/gooseneck attachment points and close-out plugs, and an integrated 7-pin connector on the driver's side pickup bed wall (requires 8-ft. box; n/a with stowable bed extender)
- Alternator – Single, extra-heavy-duty 200-amp (diesel engine only)
- Alternators – Dual, 357-amp total (diesel engine only)
- Higher-ratio rear axle (gas engine only)
- Power Code™ Remote Start System
- Power takeoff (PTO) provision – Includes transmission-mounted live drive and stationary modes (diesel engine only)

SEATING

Front seat – Heated/cooled 40/console/40 bucket seats and flow-thru console with lockable storage, two 12v powerpoints and a 110v power inverter

INTERIOR

- Floor mats – Black all-weather (deletes carpeted floor mats)
- Navigation System with Premium Sound System includes AM/FM stereo/single-CD player with MP3 capability, USB port, in-dash touch screen, voice-activated controls, SIRIUS Satellite Radio, digital clock and 8 speakers with subwoofer (requires rear view camera)
- Rapid-heat supplemental cab heater (requires diesel engine and alternator upgrade)
- Rear view camera
- Upfitter switches (4) – Located on instrument panel

EXTERIOR

- Skid plates – Transfer case and fuel tank (4x4 only)
- Bodyside mouldings – Body-colour (SRW only)
- Cab steps – 5-in. chrome tubular
- Moonroof – Power-sliding (Crew Cab only)
- Roof clearance lamps (standard on DRW)
- Stowable bed extender (F-250/F-350 SRW only)
- Tailgate step – Includes step, tailgate assist and grab bar
- Two-tone paint – Lower-accent with accent-colour wheel-lip mouldings

FORD WORK SOLUTIONSTM

Cable Lock System by Master Lock®

PACKAGES

- 4,490-kg (9,900-lb.) GVWR Package (F-250/F-350 SRW only; F-250 requires diesel engine)
- Camper Package (restrictions apply)
- Chrome Package (other restrictions apply)
- FX4 OFF-ROAD Package
- Heavy-Service Front Suspension Package
- Snow Plow Prep Package (4x4 only; restrictions apply)

SEATING, BOX AND CAB CONFIGURATIONS

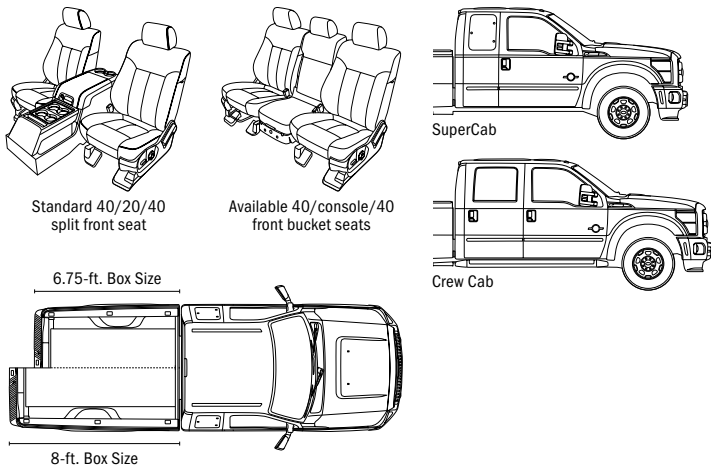

EXTERIOR



EXTERIOR COLOURS	INTERIOR COLOURS	TWO-TONE COLOURS
Oxford White	■	▲ ▲
Vermillion Red	■	
Dark Blue Pearl Metallic	■	▲
Forest Green Metallic	■	▲ ▲
Ingot Silver Metallic	■	▲
Sterling Gray Metallic	■	
Tuxedo Black Metallic	■	▲ ▲
Royal Red Metallic	■	▲
Golden Bronze Metallic	■	▲
White Platinum Metallic Tri-coat ¹	■	▲
Pale Adobe Metallic	■	

INTERIOR

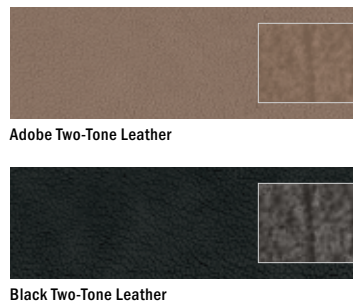

INTERIORS:
 ■ Adobe Leather ■ Black Leather
TWO-TONE COLOURS:
 ▲ Pale Adobe Metallic ▲ Sterling Gray Metallic²
¹Extra-cost option.
²Only available with Black Leather interior.

Colours are representative only. See your Ford of Canada Dealer for actual paint/trim options.

KING RANCH™



KING RANCH Chaparral Leather Seats and Black interior with available equipment.



17-in. KING RANCH
Forged, Polished-Aluminum
Included on F-350 DRW/F-450 DRW



18-in. KING RANCH
Bright-Machined, Cast-Aluminum
Included on F-250/F-350 SRW



20-in. KING RANCH
Premium Painted, Cast-Aluminum
Optional on F-250/F-350 SRW



F-450 KING RANCH Crew Cab 4x4 in Royal Red/Pale Adobe Two-Tone with Chrome Package and available equipment.

2011 ALL-NEW SUPER DUTY®

ford.ca



KING RANCH™ OPTIONAL FEATURES

MECHANICAL

- 6.7L Power Stroke® V8 Turbo Diesel B20-capable engine (standard on F-450)
- 20-in. premium painted cast-aluminum wheels with KING RANCH logo centre cap – 4 (F-250/F-350 SRW 4x4 diesel engine only)
- LT245/75R17 all-terrain BSW tires – 5 (F-350 DRW/F-450)
- LT245/75R17 all-terrain OWL tires – 4 (F-350 DRW/F-450)
- LT275/70R18 all-terrain BSW tires – 4 (F-250/F-350 SRW 4x4)
- LT275/70R18 all-terrain OWL tires – 4 (F-250/F-350 SRW 4x4)
- LT275/65R20 all-terrain OWL tires – 4 (F-250/F-350 SRW 4x4; SuperCab and Crew Cab only)
- 5th-Wheel/Gooseneck Trailer Tow Prep Package – Includes 1 under-bed frame crossmember, 5 pickup bed 5th-wheel/gooseneck attachment points and close-out plugs, and an integrated 7-pin connector on the driver's side pickup bed wall (requires 8-ft. box; n/a with stowable bed extender)
- Alternator – Single, extra-heavy-duty 200-amp (diesel engine only)
- Alternators – Dual, 357-amp total (diesel engine only)
- Higher-ratio rear axle (gas engine only)
- Power Code™ Remote Start System
- Power takeoff (PTO) provision – Includes transmission-mounted live drive and stationary modes (diesel engine only)

INTERIOR

- Navigation System with Premium Sound System includes AM/FM stereo/single-CD player with MP3 capability, USB port, in-dash touch screen, voice-activated controls, SIRIUS Satellite Radio, digital clock and 8 speakers with subwoofer
- Floor mats – Black all-weather (deletes carpeted floor mats)
- Rapid-heat supplemental cab heater (requires diesel engine and alternator upgrade)
- Rear view camera
- Upfitter switches (4) – Located on instrument panel

EXTERIOR

- Moonroof – Power-sliding
- Roof clearance lamps (standard on DRW)
- Stowable bed extender (F-250/F-350 SRW only)
- Tailgate step – Includes step, tailgate assist and grab bar

FORD WORK SOLUTIONS™

- Cable Lock System by Master Lock®

PACKAGES

- KING RANCH with Chrome Package – Includes chrome exhaust tip, chrome tow hooks, unique chrome mirror caps, chrome cargo tie-down hooks, and 6-in. chrome angular step bars
- Camper Package (restrictions apply)
- FX4 OFF-ROAD Package
- Heavy-Service Suspension Package
- Snow Plow Prep Package (4x4 only; restrictions apply)

EXTERIOR



INTERIOR



Colours are representative only. See your Ford of Canada Dealer for actual paint/trim options.

EXTERIOR COLOURS

	INTERIOR COLOURS	TWO-TONE COLOURS
Oxford White	■	▲
Forest Green Metallic	■	▲
Tuxedo Black Metallic	■	▲
Royal Red Metallic	■	▲
Golden Bronze Metallic	■	▲
White Platinum Metallic Tri-Coat ¹	■	▲

INTERIOR:

- Chaparral Leather with Adobe Environment
- Chaparral Leather with Black Environment

TWO-TONE COLOUR: ▲ Pale Adobe Metallic

¹Extra-cost option.

SEATING, BOX AND CAB CONFIGURATIONS

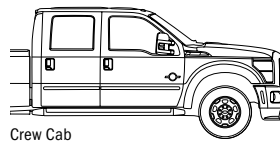
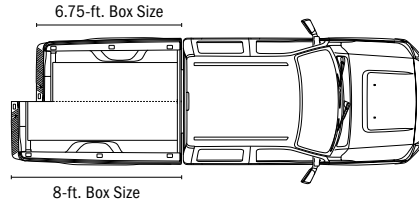

PACKAGES

4,490-kg (9,900-lb.) GVWR Package

Available on F-250 and F-350 SRW
(restrictions apply)

Advanced Security Group

Includes autolamp with rainlamp feature, autolock, auto unlock, and SecuriCode™ keyless entry keypad

Camper Package

Includes front springs upgrade (unless maximum springs have been computer-selected as included equipment), rear stabilizer bar (SRW), slide-in-camper certification, and auxiliary rear springs on F-250

Chrome Package

Includes chrome exhaust tip, chrome tow hooks, unique chrome mirror caps, chrome cargo tie-down hooks, and 6-in. chrome angular step bars

FX4 OFF-ROAD Package

Includes transfer case and fuel tank skid plates, Hill Descent Control™, Rancho® shocks, and FX4 OFF-ROAD box decals (restrictions apply)

Heavy-Service Front Suspension Package

Includes front springs upgrade (unless maximum springs have been computer-selected as included equipment) (restrictions apply)

Heavy-Service Package for Pickup Box Delete

Includes heavy-service front springs, rear stabilizer bar, and rear auxiliary springs (F-250 XL and XLT only; restrictions apply)

Power Equipment Group

Includes power door locks and front windows (plus rear on Crew Cab) with one-touch-down driver's side window feature; heated sideview mirrors; accessory delay; Remote Keyless Entry System with two integrated key transmitter remotes; and anti-theft perimeter alarm

Snow Plow Prep Package

Includes computer-selected springs for snow plow application, extra-heavy-duty alternator with diesel engine, and heavy-duty alternator with gas engines (4x4 only; restrictions apply)

Rancho is a registered trademark of Tenneco Automotive Operating Company Inc.

CLEANEST SUPER DUTY® DIESEL EVER

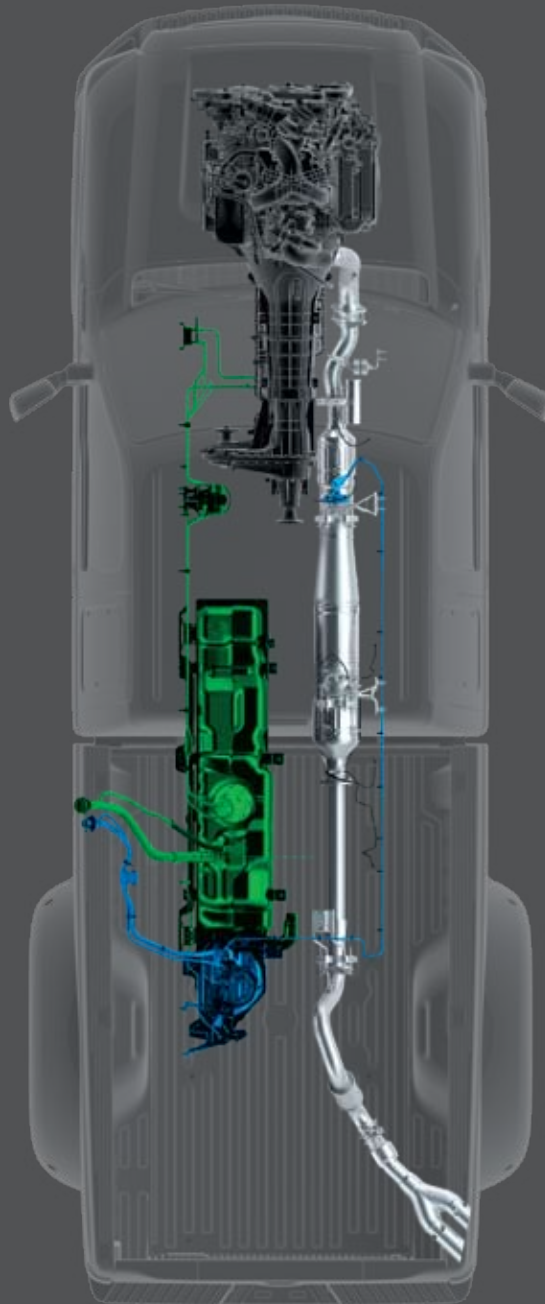

The all-new Ford 6.7L Power Stroke® V8 Turbo Diesel engine uses industry-proven technology and innovative Ford strategies to meet the latest federal emissions standards to reduce nitrogen oxide (NOx) levels by more than 80% compared to previous models.

COMBUSTION EFFICIENCY: The process begins in the engine, where combustion is optimized to help reduce emissions from the start.

CLEANING AND HEATING: When the exhaust stream enters the diesel oxidation catalyst (DOC), the hydrocarbons in it are converted and oxidized into water and carbon dioxide. Then things start heating up.

KNOCKING OUT THE NOx: Next, the exhaust stream is dosed with diesel exhaust fluid (DEF), a mixture of urea and water. In the process, the NOx in the exhaust stream is converted into inert nitrogen and water.

SCRUBBING AWAY THE SOOT: Finally, the diesel particulate filter (DPF) traps any remaining soot, which is then periodically burned away.

DOING YOUR PART: The fluid in the 18.9-litre DEF reservoir is approximately consumed over the course of each oil change interval. To help make it easy for you to refill, the blue DEF fill cap is located right next to your green diesel fuel cap. The message centre alerts you when there's about 1,200 km (800 miles) worth of DEF remaining. Ford-approved DEF can be purchased from your Ford of Canada Dealer or other authorized retailers.

The system is ready for harsh Canadian winters, with DEF and other components designed to handle freezing and thawing.



2011 ALL-NEW SUPER DUTY®

ford.ca



FORD CUSTOM ACCESSORIES



NEW 5th Wheel Hitch Kit^{1,2}



NEW Gooseneck Hitch Kit²



All-Weather Floor Mats



Soft-Folding Tonneau Cover by Advantage³



Hood Deflectors



Splash Guards

Also available:

Appearance

Chrome Exhaust Tip

Bed Products

Bed Mat

Bedliners

Bed Extender

Sport Liner Carpeted Bed Protection by BedRug^{TM3}

Soft Roll-Up Tonneau Cover by TruXedo^{®3}

Hard-Folding Tonneau Cover by REV^{®3}

Electronics

Keyless Entry Keypad

Personal Navigation Devices by Garmin^{®3}

Remote Start Systems

Vehicle Security System

Family Entertainment by INVISION^{TM3}

Windshield Wiper De-Icer and Debris Cleaner by Wiper Shaker³

Exterior

Retractable Cable Lock by Master Lock^{®3}

Hood Deflectors

Side Window Deflectors

Chrome Hitch Balls

Hitch Ball Mounts

Racks and Carriers by THULE^{®3}

Sportz[®] Truck Tents by Napier³

Step Bars

Interior

Ashcup with or without Lighter Element

Interior Soft Cargo Cooler Bag

Interior Soft Cargo Organizers (large and standard sizes)

Wheels

Wheel Covers Stainless Steel by Phoenix^{TM3}

Wheel Locks

¹Shown with a spray-in bedliner.

²Only for use with 8-ft. bed.

³Ford Licensed Accessories.

Master Lock is a registered trademark of Master Lock Company LLC.

THULE is a registered trademark of Thule Sweden AB.

Garmin is a registered trademark of Garmin LTD.

INVISION is a trademark of Audiovox Corporation.

Ford of Canada warrants that its authorized Dealers will repair or replace any Genuine Ford Accessory that is properly installed by the authorized Dealer that sold the accessory and found to be defective in factory-supplied materials or workmanship. The accessory will be warranted for whichever provides you the greatest benefit: 12 months/20,000 km (whichever occurs first), or the remainder of your 36-month/60,000-km (whichever occurs first) Basic Coverage in the New Vehicle Limited Warranty. Contact your local Ford of Canada Dealer for details.

Ford Licensed Accessories (FLA) are warranted by the accessory manufacturer's limited warranty. The warranty coverage will vary by accessory manufacturer. Ford Licensed Accessories are fully designed and developed by the accessory manufacturer and have not been designed or tested to Ford Motor Company engineering requirements. Contact your local Ford of Canada Dealer for details regarding the accessory manufacturer's limited warranty and/or for a copy of the FLA product limited warranty offered by the accessory manufacturer.



TECHNICAL SPECIFICATIONS

DIMENSIONS

EXTERIOR mm (in.)	REGULAR CAB	SUPERCAB	LWB	CREW CAB	LWB
	4x2/4x4	SWB 4x2/4x4	4x2/4x4	SWB 4x2/4x4	4x2/4x4
Height – F-250 SRW (w/o options)	1,946/2,012 (76.6/79.2)	1,956/2,019 (77.0/79.5)	1,953/2,014 (76.9/79.3)	1,966/2,024 (77.4/79.7)	1,963/2,027 (77.3/79.8)
Height – F-350 SRW (w/o options)	1,943/2,032 (76.5/80.0)	1,953/2,042 (76.9/80.4)	1,948/2,037 (76.7/80.2)	1,961/2,052 (77.2/80.8)	1,961/2,052 (77.2/80.8)
Height – F-350 DRW (w/o options)	1,948/2,019 (76.7/79.5)	–	1,953/2,024 (76.9/79.7)	–	1,963/2,029 (77.3/79.9)
Height – F-450 DRW (w/o options)	–	–	–	–	2,024 (79.7)
Overall width – SRW (excl. mirrors)	2,029 (79.9)	2,029 (79.9)	2,029 (79.9)	2,029 (79.9)	2,029 (79.9)
Overall width – DRW (excl. mirrors)	2,438 (96.0)	–	2,438 (96.0)	–	2,438 (96.0)
Overall width – With standard mirrors	2,664 (104.9)	2,664 (104.9)	2,664 (104.9)	2,664 (104.9)	2,664 (104.9)
Ground clearance – F-250 SRW	216/208 (8.5/8.2)	216/208 (8.5/8.2)	216/206 (8.5/8.1)	216/206 (8.5/8.1)	216/206 (8.5/8.1)
Ground clearance – F-350 SRW	216/208 (8.5/8.2)	216/208 (8.5/8.2)	216/208 (8.5/8.2)	216/208 (8.5/8.2)	216/208 (8.5/8.2)
Ground clearance – F-350 DRW	206/203 (8.1/8.0)	–	206/203 (8.1/8.0)	–	203/203 (8.0/8.0)
Ground clearance – F-450 DRW	–	–	–	–	203 (8.0)
Loadfloor height – F-250 SRW	894/922 (35.2/36.3)	884/904 (34.8/35.6)	874/899 (34.4/35.4)	869/892 (34.2/35.1)	866/889 (34.1/35.0)
Loadfloor height – F-350 SRW	881/978 (34.7/38.5)	874/963 (34.4/37.9)	866/965 (34.1/38.0)	861/960 (33.9/37.8)	859/958 (33.8/37.7)
Loadfloor height – F-350 DRW	889/925 (35.0/36.4)	–	871/907 (34.3/35.7)	–	866/904 (34.1/35.6)
Loadfloor height – F-450 DRW	–	–	–	–	899 (35.4)
Cargo box height	20.0	20.0	20.0	20.0	20.0
Overall length	5,781 (227.6)	5,903 (232.4)	6,314 (248.6)	6,726 (246.8)	6,680 (263.0)
Overhang – Rear	1,331 (52.4)	1,331 (52.4)	1,331 (52.4)	1,331 (52.4)	1,331 (52.4)
Wheelbase	3,480 (137.0)	3,602 (141.8)	4,013 (158.0)	3,967 (156.2)	4,379 (172.4)
Overhang – Front	968 (38.1)	968 (38.1)	968 (38.1)	968 (38.1)	968 (38.1)
Angle of departure – F-250 SRW	17.8°/19.2°	17.4°/18.5°	17.0°/18.3°	16.7°/18.0°	16.7°/17.9°
Angle of departure – F-350 SRW	17.3°/21.5°	17.0°/20.9°	16.6°/21.1°	16.4°/20.8°	16.3°/20.8°
Angle of departure – F-350 DRW	17.6°/19.3°	–	16.9°/18.7°	–	16.7°/18.5°
Angle of departure – F-450 DRW	–	–	–	–	18.3°
Ramp breakover angle – F-250 SRW	17.5°/20.4°	16.9°/19.8°	15.8°/18.1°	15.7°/18.1°	15.0°/17.3°
Ramp breakover angle – F-350 SRW	17.2°/21.5°	16.7°/20.9°	15.6°/19.2°	15.5°/19.2°	14.8°/18.2°
Ramp breakover angle – F-350 DRW	17.5°/20.4°	–	15.9°/18.6°	–	15.0°/17.4°
Ramp breakover angle – F-450 DRW	–	–	–	–	17.0°
Angle of approach – F-250 SRW	18.0°/19.4°	18.1°/20.1°	18.7°/20.0°	18.7°/20.0°	18.9°/20.6°
Angle of approach – F-350 SRW	18.1°/18.8°	18.2°/19.5°	18.8°/19.3°	18.8°/19.3°	19.0°/20.0°
Angle of approach – F-350 DRW	18.2°/19.2°	–	19.0°/20.6°	–	19.1°/20.3°
Angle of approach – F-450 DRW	–	–	–	–	19.8°

INTERIOR mm (in.)					
Front head room	1,034 (40.7)	1,034 (40.7)	1,034 (40.7)	1,034 (40.7)	1,034 (40.7)
Front shoulder room	1,727 (68.0)	1,727 (68.0)	1,727 (68.0)	1,727 (68.0)	1,727 (68.0)
Front hip room	1,717 (67.6)	1,717 (67.6)	1,717 (67.6)	1,717 (67.6)	1,717 (67.6)
Front leg room	1,044 (41.1)	1,044 (41.1)	1,044 (41.1)	1,044 (41.1)	1,044 (41.1)
Rear head room	–	968 (38.1)	968 (38.1)	1,036 (40.8)	1,036 (40.8)
Rear shoulder room	–	1,730 (68.1)	1,730 (68.1)	1,727 (68.0)	1,727 (68.0)
Rear hip room	–	1,709 (67.3)	1,709 (67.3)	1,717 (67.6)	1,717 (67.6)
Rear leg room	–	803 (31.6)	803 (31.6)	1,069 (42.1)	1,069 (42.1)

CARGO BOX mm (in.)					
Volume litres (cu. ft.)	2,189 (77.3)	1,815 (64.1)	2,189 (77.3)	1,815 (64.1)	2,189 (77.3)
Width at floor (maximum)	1,760 (69.3)	1,760 (69.3)	1,760 (69.3)	1,760 (69.3)	1,760 (69.3)
Length at floor	2,489 (98.0)	2,078 (81.8)	2,489 (98.0)	2,078 (81.8)	2,489 (98.0)
Width at wheelhouse	1,293 (50.9)	1,293 (50.9)	1,293 (50.9)	1,293 (50.9)	1,293 (50.9)

SRW = single rear wheel DRW = dual rear wheel SWB = short wheelbase (6.75-ft. cargo box) LWB = long wheelbase (8-ft. cargo box)

CONVENTIONAL TOWING – MAXIMUM LOADED TRAILER WEIGHT RATINGS

AUTOMATIC TRANSMISSION			REGULAR CAB				SUPERCAB				
ENGINE	AXLE RATIO	GCWR kg (lbs.)	F-250/F-350 SRW 4x2	F-350 DRW 4x2	F-250/F-350 SRW 4x4	F-350 DRW 4x4	F-250/F-350 SRW 4x2	F-350 DRW 4x2	F-250 SRW 4x4	F-350 SRW 4x4	F-350 DRW 4x4
6.2L 2-valve FFV	3.73	8,618 (19,000) 8,845 (19,500)	5,670 (12,500)	–	5,625 (12,400)	–	5,670 (12,500)	–	5,534 (12,200)	5,489 (12,100)	–
	4.30	9,979 (22,000) 10,206 (22,500)	5,670 (12,500)	5,851 (12,900)	5,670 (12,500)	5,625 (12,400)	5,670 (12,500)	5,670 (12,500)	5,670 (12,500)	5,670 (12,500)	5,489 (12,100)
6.7L Diesel	3.31	10,660 (23,500)	5,670 (12,500)	–	5,670 (12,500)	–	6,350 (14,000)	–	6,260 (13,800)	6,350 (14,000)	–
	3.55	10,660 (23,500)	5,670 (12,500)	–	5,670 (12,500)	–	6,350 (14,000)	–	6,260 (13,800)	6,350 (14,000)	–
	3.73	13,154 (29,000)	–	6,804 (15,000)	–	6,804 (15,000)	–	6,804 (15,000)	–	–	6,804 (15,000)
	4.30	14,969 (33,000)	–	–	–	–	–	–	–	–	–

CREW CAB						
F-250 SRW 4x2	F-350 SRW 4x2	F-350 DRW 4x2	F-250 SRW 4x4	F-350 SRW 4x4	F-350 DRW 4x4	F-450 DRW 4x4
5,625 (12,400)	5,625 (12,400)	–	5,443 (12,000)	5,398 (11,900)	–	–
–	–	5,534 (12,200)	–	–	5,352 (11,800)	–
5,670 (12,500)	5,670 (12,500)	–	5,670 (12,500)	5,670 (12,500)	–	–
–	–	6,804 (15,000)	–	–	6,713 (14,800)	–
6,350 (14,000)	6,350 (14,000)	–	6,350 (14,000)	6,350 (14,000)	–	–
6,350 (14,000)	6,350 (14,000)	–	6,350 (14,000)	6,350 (14,000)	–	–
–	–	6,804 (15,000)	–	–	7,258 (16,000)	–
–	–	–	–	–	–	7,258 (16,000)

Conventional Towing Notes: This information also applies to models with pickup box delete option (66D). Trailer tongue load weight should be 10–15% of total loaded trailer weight. Make sure that the vehicle payload (reduced by option weight) will accommodate trailer tongue load weight and the weight of passengers and cargo added to the towing vehicle. The addition of trailer tongue load weight, and the weight of passengers and cargo, cannot cause vehicle weights to exceed the rear GAWR (Gross Axle Weight Rating) or GVWR (Gross Vehicle Weight Rating). These ratings can be found on the vehicle Safety Compliance Certification Label. For F-250/F-350 SRW models, F-250 trailer weights are shown; F-350 trailer weights are within 91 kg (200 lbs.). Check with your sales consultant.



POWERTRAINS

	6.2L 2-VALVE GAS	6.7L V8 TURBO DIESEL
Configuration	SOHC	OHV (32-valve)
Fuel injection	Sequential electronic	High-pressure common-rail
Engine control system	Electronic	Electronic
Induction system	Specially tuned	Single-sequential turbocharger with charged air cooler
Battery	12-volt; 650-CCA/72-amp	Dual 12-volt; 750-CCA/78-amp
Alternator	157-amp	157-amp (single 200-amp or dual combined 357-amp, optional)
Cooling system	Pressurized series flow	Pressurized series flow
Cylinders	8	8
Cylinder head	Aluminum	Aluminum
Block material	Cast iron	Compacted graphite iron
Valve operation	Roller rocker shaft	Push rod/rocker arms
Camshaft drive	Silent chain	Gear
Bore	4.02-in.	3.90-in.
Stroke	3.74-in.	4.25-in.
Compression ratio	9.8:1	16.2:1
Horsepower/rpm	385 @ 5,500 ¹	390 @ 2800
Torque lb.-ft./rpm	405 @ 4,500 ¹	735 @ 1600
Recommended fuel	Regular unleaded or E85	Ultra-low-sulfur diesel or B20 (containing 20% or less BioDiesel)

¹Certified to SAE J1349. 385 hp and 405 lb.-ft. of torque under 4,536 kg (10,000 lb.) GVWR. 316 hp @ 4,179 rpm and 397 lb.-ft. of torque @ 4,179 rpm over 4,536 kg (10,000 lb.) GVWR.

MECHANICAL

FRONT SUSPENSION	
Type	Twin-I-beam (F-250/F-350 4x2); solid twin-coil monobeam axle (F-250/F-350 4x4, F-450 4x4)
Axle (rating @ ground)	2,381 kg (5,250 lbs.) (F-250/F-350 4x2); 2,722 kg (6,000 lbs.) (F-250/F-350 4x4); 3,175 kg (7,000 lbs.) (F-450)
Springs	Coil
Shock absorbers	35-mm (1.38-in.) gas-type
Stabilizer bar	Standard
REAR SUSPENSION	
Type	Full floating axle
Axle (rating @ ground)	2,812 kg (6,200 lbs.) (F-250); 3,302 kg (7,280 lbs.) (F-350 SRW); 4,082 kg (9,000 lbs.) (F-350 DRW); 4,990 kg (11,000 lbs.) (F-450)
Springs	Leaf
Shock absorbers	35-mm (1.38-in.) gas-type
Stabilizer bar	Standard on DRW pickup; optional in package on SRW pickup
STEERING	
Assist	Power
Overall ratio	20.35:1 (F-250/F-350 4x2); 19.77:1 (F-250/F-350 4x4); 20.38:1 average (F-450)
BRAKES	
Type	4-wheel vented-disc ABS with Roll Stability Control™ (standard)
Front (rotor diameter)	347-mm (13.66-in.) (F-250/F-350); 369-mm (14.53-in.) (F-450)
Rear (rotor diameter)	340-mm (13.39-in.) (F-250/F-350); 390-mm (15.35-in.) (F-450)
WHEELS	
Type	Steel or aluminum
Size	17-in., 18-in. or 20-in. (F-250/F-350); 17-in. (F-450)
Bolt-circle diameter	170-mm (6.7-in.) SRW; 200-mm (7.87-in.) DRW

5TH-WHEEL TOWING — MAXIMUM LOADED TRAILER WEIGHT RATINGS

ENGINE	AUTOMATIC TRANSMISSION			REGULAR CAB					SUPERCAB				
	AXLE RATIO	GCWR kg (lbs.)	F-250 SRW 4x2	F-350 SRW 4x2	F-350 DRW 4x2	F-250 SRW 4x4	F-350 SRW 4x4	F-350 DRW 4x4	F-250/F-350 SRW 4x2	F-350 DRW 4x2	F-250 SRW 4x4	F-350 SRW 4x4	F-350 DRW 4x4
6.2L 2-valve FFV	3.73	8,618 (19,000)	5,761 (12,700)	5,715 (12,600)	—	5,534 (12,200)	5,489 (12,100)	—	5,670 (12,500)	—	5,534 (12,200)	5,489 (12,100)	—
	4.30	8,845 (19,500)	—	—	5,761 (12,700)	—	5,534 (12,200)	—	—	5,579 (12,300)	—	—	—
		9,979 (22,000)	7,122 (15,700)	7,076 (15,600)	—	6,895 (15,200)	6,849 (15,100)	—	7,031 (15,500)	—	6,895 (15,200)	6,849 (15,100)	—
6.7L Diesel	3.31	10,660 (23,500)	7,484 (16,500)	7,484 (16,500)	—	7,303 (16,100)	7,258 (16,000)	—	7,439 (16,400)	—	7,303 (16,100)	7,303 (16,100)	—
	3.55	10,660 (23,500)	7,484 (16,500)	7,484 (16,500)	—	7,303 (16,100)	7,258 (16,000)	—	7,439 (16,400)	—	7,303 (16,100)	7,303 (16,100)	—
	3.73	13,154 (29,000)	—	—	9,798 (21,600)	—	—	9,571 (21,100)	—	9,571 (21,100)	—	—	9,299 (20,500)
	4.30	14,969 (33,000)	—	—	—	—	—	—	—	—	—	—	—

CREW CAB						
F-250 SRW 4x2	F-350 SRW 4x2	F-350 DRW 4x2	F-250 SRW 4x4	F-350 SRW 4x4	F-350 DRW 4x4	F-450 DRW 4x4
5,625 (12,400)	5,579 (12,300)	—	5,443 (12,000)	5,398 (11,900)	—	—
—	—	5,443 (12,000)	—	—	5,262 (11,600)	—
6,985 (15,400)	6,940 (15,300)	—	6,804 (15,000)	6,759 (14,900)	—	—
—	—	6,804 (15,000)	—	—	6,623 (14,600)	—
7,258 (16,000)	7,258 (16,000)	—	7,122 (15,700)	7,167 (15,800)	—	—
7,258 (16,000)	7,258 (16,000)	—	7,122 (15,700)	7,167 (15,800)	—	—
—	—	9,435 (20,800)	—	—	9,208 (20,300)	—
—	—	—	—	—	—	11,068 (24,400)

5th-Wheel Towing Notes: This information also applies to models with pickup box delete option (66D). Trailer kingpin weight should be 15–25% of total loaded trailer weight. Make sure that the vehicle payload (reduced by option weight) will accommodate trailer kingpin weight and the weight of passengers and cargo added to the towing vehicle. The addition of trailer kingpin weight, and the weight of passengers and cargo, cannot cause vehicle weights to exceed the rear GAWR (Gross Axle Weight Rating) or GVWR (Gross Vehicle Weight Rating). These ratings can be found on the vehicle Safety Compliance Certification Label. For F-250/F-350 SRW models, F-250 trailer weights are shown; F-350 trailer weights are within 91 kg (200 lbs.). Check with your sales consultant. Maximum capabilities shown are for properly equipped vehicles with required equipment and a 68-kg (150-lb.) driver. Weight of additional options, equipment, passengers and cargo must be deducted from this weight. For additional information, see your Ford of Canada Dealer.

MAXIMUM PAYLOAD WEIGHT RATINGS kg (lbs.)

	MAX. GVWR KG (LBS.)	REGULAR CAB 137.0-IN. WB	SUPERCAB 141.1-IN. WB	158.0-IN. WB	CREW CAB 156.2-IN. WB	172.4-IN. WB
F-250 SRW 4x2	4,264 (9,400)	—	1,370 (3,020)	1,388 (3,060)	1,315 (2,900)	—
	4,355 (9,600)	—	—	—	—	1,343 (2,960)
	4,445 (9,800)	1,837 (4,050)	1,293 (2,850)	—	—	—
	4,536 (10,000)	—	—	1,320 (2,910)	1,202 (2,650)	1,207 (2,660)
F-250 SRW 4x4	4,264 (9,400)	1,334 (2,940)	1,229 (2,710)	—	—	—
	4,355 (9,600)	—	—	1,261 (2,780)	1,220 (2,690)	—
	4,445 (9,800)	—	—	—	—	1,266 (2,790)
	4,536 (10,000)	1,334 (2,940)	1,220 (2,690)	1,066 (2,350)	1,102 (2,430)	1,002 (2,210)
F-350 SRW 4x2	4,627 (10,200)	1,873 (4,130)	1,683 (3,710)	—	—	—
	4,808 (10,600)	—	—	2,087 (4,600)	1,810 (3,990)	—
	4,899 (10,800)	1,842 (4,060)	—	—	—	1,837 (4,050)
	4,990 (11,000)	—	1,787 (3,940)	—	—	—
	5,080 (11,200)	—	—	1,819 (4,010)	1,696 (3,740)	—
	5,171 (11,400)	—	—	—	—	1,792 (3,950)
F-350 SRW 4x4	4,854 (10,700)	1,860 (4,100)	—	—	—	—
	4,899 (10,800)	—	1,801 (3,970)	—	—	—
	4,990 (11,000)	—	—	1,837 (4,050)	1,796 (3,960)	—
	5,080 (11,200)	1,819 (4,010)	—	—	—	1,837 (4,050)
	5,171 (11,400)	—	1,792 (3,950)	—	—	—
	5,216 (11,500)	—	—	1,687 (3,720)	1,719 (3,790)	1,624 (3,580)
F-350 DRW 4x2	5,715 (12,600)	2,508 (5,530)	—	2,690 (5,930)	—	2,477 (5,460)
	5,806 (12,800)	2,957 (6,520)	—	—	—	—
	5,897 (13,000)	—	—	2,459 (5,420)	—	2,341 (5,160)
F-350 DRW 4x4	5,534 (12,200)	2,386 (5,260)	—	—	—	—
	5,715 (12,600)	—	—	2,400 (5,290)	—	2,295 (5,060)
	5,806 (12,800)	2,372 (5,230)	—	—	—	—
	5,897 (13,000)	—	—	2,204 (4,860)	—	2,132 (4,700)
F-450 DRW 4x4	5,919 (13,050)	—	—	—	—	2,232 (4,920)

WB = wheelbase

Our commitment to you... Peace-of-Mind Protection

- **Basic Coverage:** 3 years/60,000 km
- **Powertrain Limited Warranty:** 5 years/100,000 km
- **Direct-Injection Diesel Engine:** 5 years/160,000 km (if equipped). In addition, on all 2011 Model F-Series Super Duty vehicles equipped with the diesel engine, the Powertrain warranty is extended to 5 years/160,000 km (whichever occurs first), which equals the diesel engine warranty
- **Corrosion Warranty:** 5 years/unlimited distance
- **Roadside Assistance:** 5 years/100,000 km

Certain conditions apply. For more information on these warranties and coverages, ask your local Ford of Canada Dealer or visit ford.ca.

Ford Extended Service Plan

Help protect your investment and add to your peace of mind by complementing your vehicle purchase or lease with a Ford Extended Service Plan (ESP). Ford ESP protects you against unexpected repair costs after your New Vehicle Basic Warranty expires by covering many vehicle components. Enjoy the drive even more by complementing your ESP with a prepaid maintenance plan, which covers all required scheduled maintenance for your vehicle, plus 8 wear items. See your Ford of Canada Dealer for details.

Ford Credit

Get the ride you want. Whether you plan to lease or finance, you'll find the choices that are right for you at Ford Credit. Ask your local Ford of Canada Dealer for details or check us out at fordcredit.ca.

For prompt, courteous answers to your questions:

Ford Customer Relationship Centre
1-800-565-3673

Ford Credit Customer Service Centre
1-877-636-7346



Drive smart.

With available exclusives like the latest Ford SYNC® and Ford Work Solutions,™ Ford Trucks offer you more innovative technology and productivity tools than ever before.



Drive green.

Ford offers 30 vehicles that get 8.3L/100 km (34 mpg) highway or better.¹



Drive quality.

The ultimate proving ground for Ford's quality commitment is your driving experience. Drive one and you'll feel it.



Drive safe.

Ford has received more NHTSA 5-Star ratings than any other brand... ever.²

¹2011 and 2010 model year ratings: 8.3L/100 km highway and 12.7L/100 km city or better on 30 vehicles, based on powertrain and body style. Fuel consumption ratings based on Transport Canada approved test methods. Actual fuel consumption may vary based on road conditions, vehicle loading, vehicle equipment and driving habits. ²Historic brand totals. 2011 model year to be tested. Star ratings are part of the U.S. Department of Transportation's Safercar.gov program (www.safercar.gov).

Please note: The electronic version of the Ford of Canada vehicle brochure is a condensed version of the original printed version.

Competitive comparisons are based on 2010 competitive models, publicly available information and Ford data at the time of printing of the 2011 original printed version. Some features discussed may be optional. Vehicles shown may contain optional equipment. Features shown may be offered only in combination with other options or subject to additional ordering requirements or limitations. Dimensions shown may vary due to optional features and/or production variability. Following publication of the 2011 original printed brochure, certain changes in standard equipment, options and the like, or product delays may have occurred which would not be included in these pages. Your Ford of Canada Dealer is your best source for up-to-date information. Ford Motor Company of Canada, Limited, reserves the right to change product specifications at any time without incurring obligations. Colours may not be exactly as illustrated. Please see your sales consultant for specific colour and model availability. Please visit your local dealer or ford.ca for complete vehicle details

ford.ca



2011
ALL-NEW SUPER DUTY®