

R8 GT

Audi R8 GT Spyder

 **Audi Sport**
performance cars



Unlimited intensity. **The Audi R8 GT Spyder.**



1/min x 1000

V10

16:29
23.04.2011

R8GT

140
km/h

A close-up, black and white photograph of the interior of an Audi R8 GT. The image focuses on the steering wheel, which features a prominent Audi logo in the center. The dashboard and instrument cluster are visible, showing various gauges and controls. The leather upholstery of the steering wheel and dashboard is detailed with stitching. The overall aesthetic is one of luxury and performance.

A new breathtaking model has been added to the R8 family. The Audi R8 GT Coupé is now joined by its open-top counterpart: the Audi R8 GT Spyder. It too is strictly limited to just 333 cars worldwide, so it is sure to become a piece of motoring history.

Unlimited enjoyment.







The Audi R8 GT Spyder will change everything you knew about open-top driving.
It's more intensive, more exhilarating, more athletic. Every drive in it will thrill
you – whatever the weather.





An aerial, black and white photograph of a vast, flat desert landscape. The ground is covered in a complex network of tire tracks, suggesting a high-speed driving experience. In the upper left corner, a dark, sharp shadow of a car is cast onto the ground, indicating the car is positioned just out of the frame. The overall scene conveys a sense of open space and freedom.

Inside the Audi R8 GT Spyder sits a 5.2-litre V10 mid-engine that delivers an outstanding 560PS. You only need to listen to its distinctive growling sound to know what immense power lies within it. A sound that evokes feelings of pure joy every time you turn the key. The V10 powerplant, which operates according to the tried-and-tested high-revving concept, is equipped with the FSI® petrol direct injection technology that has powered Audi to victory in motor racing. As well as an extra boost of power, maximum torque has also been increased, to 540 Nm at 6,500 rpm. The R8 GT Spyder develops this into particularly dynamic forward thrust across the entire rev range, up to 8,700 rpm.

The cylinder angle of 90° gives the engine a low centre of gravity. Dry sump lubrication guarantees a reliable supply of oil even under extreme lateral acceleration. It also allows the engine to be installed low – as a mid-engine near the vehicle's vertical axis in order to enhance agility and handling. Power is transmitted to all four wheels via the quick-shifting R tronic. This automated manual gearbox offers two manual and two fully automatic modes, and changes gear faster than any driver: gear changes take around just one tenth of a second at high engine loads and revs.

Unlimited driving pleasure.

Unlimited emotion.







The challenge when designing the Audi R8 GT Spyder was to make it weigh even less than the Audi R8 Spyder, a car already packed with extensive lightweight design expertise, including the Audi Space Frame (ASF), carbon fibre-reinforced polymer (CFRP) components and a fabric hood. The solution was to make use of the outstanding DNA and evolve it further. While numerous design modifications were made on the one hand, more extensive use was also made of ultra-light CFRP as a material. Many visible details in matt carbon underline how the lightweight design concept has been systematically implemented. The final result: the R8 GT Spyder weighs an impressive 85 kilograms less than the comparable R8 Spyder. The noticeable consequence of this is that the sporty power-to-weight ratio of 3.98 kilograms per kW allows this mid-engined sports car to accelerate from 0 to 100 km/h in just 3.8 seconds. Its top speed is reached at 197mph*.

*Where law permits.

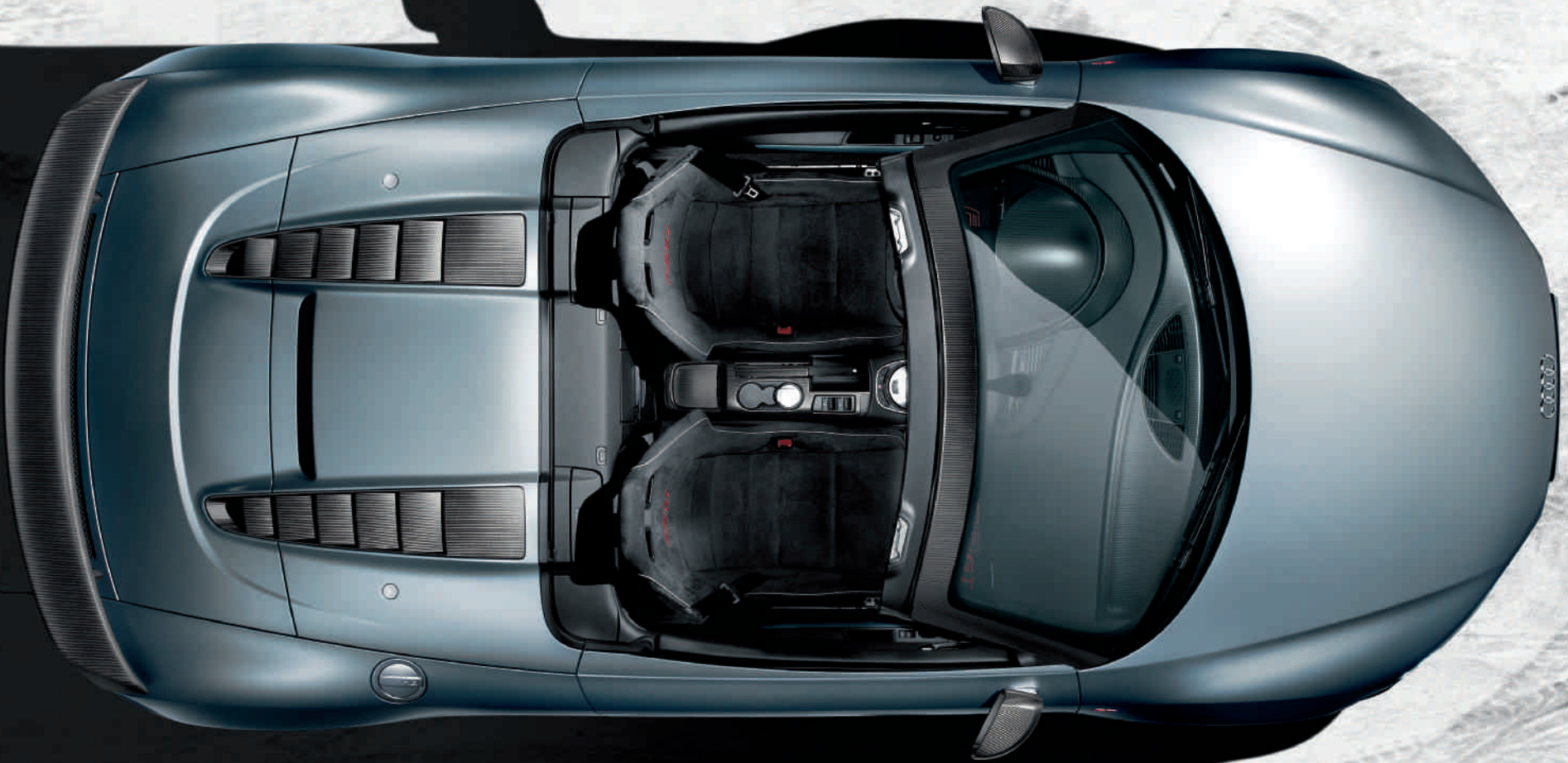



The stunning lines of the R8 GT Spyder will leave a lasting impression; the characteristic front end of the Audi R8 with its angled LED headlights with integrated daytime running lights is instantly recognisable. Numerous details make the R8 GT Spyder stand out: the matt black radiator grille and single frame surround as well as the side air inlets in matt titanium grey immediately indicate this car's exclusive status. The housings of the twin-arm exterior mirrors are manufactured from matt carbon and, to extend this look further, the flat windscreen frame can also be specified in this material at an additional cost. The enlarged front spoiler and additional flics located on the side of the bumper are also made from carbon fibre composite and provide extra downforce on the front axle.

An aerial, black and white photograph of a vast, flat desert landscape. The ground is covered in numerous overlapping, curved tire tracks that create a complex pattern across the terrain. In the bottom left corner, a dark, solid black shape represents the shadow of a car, cast from the left side of the frame. The overall scene conveys a sense of speed and exploration in a remote, open environment.

Unlimited enthusiasm.

The back end of the R8 GT Spyder rounds off what started at the front of the car. The quattro® permanent all-wheel drive system has a rear-wheel bias in order to consistently exploit the advantages of the mid-engine concept and enhance the car's handling performance. Apart from the large matt black tailpipe trims, the LED rear lights in a clear-glass design with black inserts are an immediate distinguishing feature of the R8 GT Spyder. The bumper with contrasting paint finish and titanium grey slats enhance its stunning road presence, and the rear end also provides a visible indication of the car's lightweight construction. Newly designed parts such as the air outlets on the hood compartment lid and the larger diffuser insert are made of matt carbon, as is the fixed rear spoiler that further increases downforce on the rear axle.





IN GT 8002





IN GT 8002



Unlimited fascination.

High-performance ceramic brakes are standard on the R8 GT Spyder. Their red anodized brake callipers with “Audi ceramic” inscription are visible through the forged 19-inch 5 twin-spoke Y design wheels in titanium finish. The brake discs are made from carbon fibre-reinforced ceramic. This hard, virtually abrasion-resistant material is much more durable than comparable steel discs under identical operating conditions, and weighs less too. At the same time, it withstands high thermal stress, which helps to increase the brakes' resistance to fading. The new sports suspension that has been specially developed for the R8 GT lowers the ride height by 10 millimetres, generating added dynamism and fun at the wheel.

Unlimited racing atmosphere.

No matter whether you have the hood up or down – the Audi R8 GT Spyder is unmistakably inspired by a racing car. The cockpit is surrounded by the characteristic matt carbon monoposto. The sensation can be further enhanced by the numerous features that are additionally available, such as the instrument cowl, inlays and seat shells in matt carbon. The shift paddles on the Alcantara R8 GT sports steering wheel give you even better control of gear changes, while the instrument cluster with its white dials makes sure you can take in all key information at a glance.







High-quality materials, crafted with precision and attention to detail, transform the interior into something quite individual. The sports bucket seats are made of glass fibre-reinforced polymer (GFRP) with black Alcantara upholstery and provide you with outstanding support. The seat shells can be ordered either painted in the body colour or in matt carbon. The backrests can be adorned with a red embroidered R8 GT logo if desired. The Bluetooth interface keeps you in touch with the outside world – the voice quality is outstanding even with the hood down thanks to the integrated belt microphones. And if you should prefer to listen to music rather than just the pure sound of the engine, then you can enjoy the excellent quality of the Bang & Olufsen Sound System, which is available at no additional cost.

Limited edition. **Unlimited desire.**

The badge on the gear knob tells you which of the 333 limited-edition Audi R8 GT Spyder models is yours. Every time you shift gear, not only will you feel the car's irrepressible power, you will also enjoy the special feeling that comes with owning it. It's an exclusive and intense feeling.



It is the equipment
that turns an Audi into your Audi.

R8 GT Spyder

Engine	Power	Transmission	CO ₂ g/km	Basic RRP	Total RRP inc VAT	Recommended OTR
5.2 FSI quattro	560PS	R tronic	332	£130,416.67	£156,500.00	£158,145.00

Paint finishes



■ Glacier white, metallic



NC



■ Sphere blue, matt effect

£4,800.00



■ Phantom black, pearl effect



NC



■ Suzuka grey, matt effect

£4,800.00

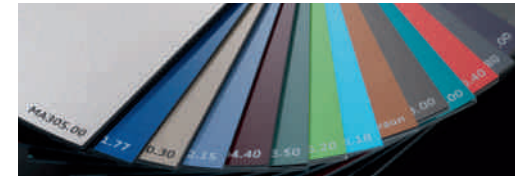

■ Audi exclusive paint finishes

£2,450.00

Please note: The maximum power output figures are quoted in PS (or Pferdestärke, which is the metric equivalent of brake horsepower). To convert to brake horsepower, divide the PS figure by 1.0139. Recommended On-The-Road (OTR) retail prices include: delivery charge, half a tank of fuel, number plates at £590.00 (inc. VAT), Road Fund Licence and first registration fee at £55.00. Vehicle Excise Duty correct at time of going to print, but this may alter to reflect any change in the applicable VED rate. RRP – Recommended Retail Price. VAT is calculated at 20% but this may alter to reflect any change in the applicable VAT rate).

Hood



■ Hood, black

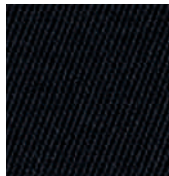

S

Seats/seat upholstery/leather interiors



■ Alcantara, black
with contrasting seam in titanium grey NC



■ Alcantara, black
with contrasting seam in crimson red NC

■ Audi exclusive sports bucket seats

for optimum lateral support, shells made from glass fibre-reinforced polymer (GFRP) in black, with manual fore/aft adjustment; upholstered in black Alcantara with contrasting seam and piping in titanium grey or crimson red

S

■ Audi exclusive sports bucket seats body-coloured

same as Audi exclusive sports bucket seats, but shells body-coloured

£1,450.00

■ Audi exclusive sports bucket seats in Carbon, matt

same as Audi exclusive sports bucket seats, but with shells made from carbon fibre-reinforced polymer (CFRP) finish in Carbon, matt

£2,650.00

■ Sports seats

with prominent side sections for superior lateral support, electric adjustment of fore/aft position, seat height, seat cushion and backrest angle, including electrically adjustable 4-way lumbar support and seat heating; upholstered in black with contrasting seams in titanium grey or crimson red, head restraints and seat side sections in leather incl. heat protection, seat centre sections in Alcantara

NC

■ R8 GT logo for sports bucket seats

in red
£450.00

■ Contrasting seams

available in titanium grey or crimson red for seats, door trim, knee pad and sports steering wheel
NC

■ R8 GT Spyder full leather interior

seat upholstery (incl. heat protection), dashboard, instrument cowl, door trim including top shoulder, door storage pockets, rear side panel trim as well as knee pad and function pad in black Fine Nappa leather with contrasting seams in titanium grey or crimson red

£6,600.00

NC - No cost

S - Standard

Wheels/tyres



■ Forged aluminium wheels in 5 double-spoke Y design in **titanium look**, size 8.5 J x 19 at front, size 11 J x 19 at rear, with 235/35 R 19 tyres at front and 295/30 R 19 tyres at rear S



■ Audi exclusive forged aluminium wheels in 5 double-spoke Y design in **matt silver look**, size 8.5 J x 19 at front, size 11 J x 19 at rear, with 235/35 R 19 tyres at front and 305/30 R 19 tyres at rear **£670.00**



■ Audi exclusive forged aluminium wheels in 5 double-spoke design in **titanium look**, size 8.5 J x 19 at front, size 11 J x 19 at rear, with 235/35 R 19 tyres at front and 305/30 R 19 tyres at rear **£670.00**

■ **Sports tyres: Audi exclusive forged aluminium wheels in 5 double-spoke design in titanium look,** size 8.5 J x 19 at front, size 11 J x 19 at rear, with 235/35 R 19 high-performance tyres at front and 305/30 R 19 high-performance tyres at rear; extra set of wheels for use on the racetrack or during driver safety training sessions, approved for use on public roads. Because the tyres are better adapted to dry road surfaces, some limitations on performance are to be expected in the wet. Driving style should be adjusted accordingly
£5,000.00

■ **Wheel bolts, anti-theft**
can only be loosened using adapter provided
S

■ **Tyre repair kit**
12-volt compressor and tyre located under the loading floor cover in the luggage compartment, top speed 80 km/h
S

■ **Tyre pressure control display**
visual and acoustic warning if the pressure drops in one or more tyres; display in the driver information system
S

■ **Vehicle tool kit**
in the luggage compartment under the loading floor
S

■ **Jack**
in the luggage compartment under the loading floor
S

NC - No cost
S - Standard

Inlays

■ Audi exclusive inlays

monoposto and door handles in Carbon, matt; inlays in doors and centre console body-coloured

S

■ Audi exclusive inlays in matt carbon

for doors and centre console

£1,590.00

Lights

■ **LED headlights including headlight cleaning system** dipped beam, high beam, daytime running lights and indicators in full LED technology enable a near-day-light illumination of the road

S

■ LED rear lights

brake lights, third brake light, indicators and licence plate lights in LED technology; rear lights in clear-glass design with black inserts

S

Mirrors

■ Exterior mirrors with integral LED indicators

of lightweight construction and in R8 GT-specific design; electrically adjustable and heated, convex, flat or aspherical mirror glass; housing in Carbon, matt; mirror base in aluminium

S

Prices shown are RRP.

Roof systems

■ Fin hood, fully automatic

made of insulated, 3-ply fabric with optimised material thickness and connection for less noise inside the vehicle; hood can be opened at speeds up to 31mph with one-touch control

S

■ Wind deflector

can be stowed in the luggage compartment inside a bag

S

Closing systems

■ Anti-theft alarm system

including interior monitoring and tow-away protection using tilt angle sensor, can be deactivated

S

■ Fitting for Tracking Assistant

fitting for the connecting of a Tracking Assistant (available from Audi Genuine Accessories), by means of which the stolen vehicle can be located

S

Further exterior equipment

■ Windscreen frame

choice of:

in aluminium

S

in Carbon, matt

£3,200.00

■ Bumpers

in R8 GT-specific design; with spoiler in Carbon, matt and air inlets in black, matt with slats in Titanium grey, matt at the front; with air outlets, slats and area between the air outlets in Titanium grey, matt at the rear; enlarged diffuser insert in Carbon, matt, plus additional air outlets on the left and right

S

■ Audi single-frame

radiator grille in black, matt with horizontal and vertical struts as well as frame finished in Titanium grey, matt

S

■ Flics

in Carbon, matt on the sides of the front bumper to increase the contact pressure

S

■ Front spoiler

body-coloured

£280.00

■ Exhaust system

dual-branch, with circular, lightweight tailpipe trims in black, matt

S

■ Sill extensions

body-coloured

S

■ Air outlets in Carbon, matt

on the hood compartment lid

S

■ R8 GT rear spoiler

in Carbon, matt, fixed

S

■ GT emblem

in anodized red, on the side of the bonnet

S

■ Audi exclusive engine compartment cover

in Carbon, matt

£3,400.00

NC - No cost

S - Standard

Steering wheels/gear levers/controls

■ **R8 GT multi-function Sports steering wheel**, flat-bottomed, heavily contoured steering wheel rim with ergonomic design and buttons for operating all Audi audio systems and the Bluetooth interface, with R8 GT badge and full-size airbag, adjustable for height and reach; trimmed in Alcantara, black with contrasting stitching in interior colour, aluminium-look shift paddles behind the steering wheel; handbrake grip in Alcantara, black

S

■ R8 GT gear knob

in aluminium with R8 GT badge and limited-edition number; gear lever made from carbon fibre-reinforced polymer (CFRP) in R8 GT-specific design

S

■ Audi exclusive controls

in black with decorative seams in titanium grey or crimson red; leather trim for steering wheel rim and handbrake gear grip

£655.00

Air conditioning

■ Automatic Air conditioning

in special R8 design, CFC-free, with sun sensor; controls air temperature, volume and distribution electronically; air circulation control and recirculation mode, activated charcoal filter

S

Luggage securing and storage systems

■ Storage compartment

lockable, illuminated in LED technology, integrated into rear panel

S

■ Glove compartment

on the front passenger side, lockable, with light and spectacles compartment

S

■ Storage package

storage nets on the seat backs, storage compartment under the seats. (Can only be ordered in conjunction with sports seats)

£195.00

Further interior equipment

■ Pedals and footrest

in aluminium look

S

■ Footwell trim and floor mats

in velour, black

S

■ Floor mats with R8 GT logo

in black with leather piping in titanium grey or crimson red. R8 GT logo in red

£510.00

■ Knee pad

in Alcantara, black with contrasting seams in interior colour

S

■ Door sill trims with aluminium inlay

and R8 GT logo on the door sills

S

■ Audi exclusive door sill trims in Carbon, matt

with aluminium inlay and R8 GT logo on the door sills

£1,275.00

■ Audi exclusive door sill trims in Carbon, matt

with illuminated aluminium inlay

the inner edging of the aluminium inlay and the R8 GT logo are illuminated

£1,990.00

■ Audi exclusive door sill trims in Carbon, matt

with personalised illuminated aluminium inlay

the aluminium inlay in the door sill trim can be personalised with lettering on request.

Please contact your Audi Centre for more information

£2,800.00

■ Audi exclusive centre console cover body-coloured

including handbrake cover

£1,125.00

■ Audi exclusive centre console cover

in Carbon, matt

including handbrake cover

£1,225.00

■ Audi exclusive instrument cowl

in Carbon, matt

including insert for top of dashboard

£1,480.00

■ Windscreen frame in Alcantara

interior trim of the windscreen frame including sun visors trimmed in Alcantara, black

S

■ Audi exclusive windscreen frame

in Fine Nappa leather interior trim of the windscreen frame including sun visors trimmed in Fine Nappa leather, black

NC

■ Audi exclusive rear panel trim in Alcantara

in black

£1,125.00

■ Audi exclusive luggage compartment lining

in Alcantara in black with contrasting seams in titanium grey or crimson red

£1,645.00

MMI® and navigation systems

■ Navigation system plus with MMI® operating logic

including two navigation DVDs, 6.5-inch TFT colour display (800 x 480 pixels) with 3D map rendering, dynamic route guidance (where available), radio with twin tuner, DVD drive for navigation DVD, audio or MP3 CDs (cannot be played when navigation system is being used), 2 integrated MMC/SDHC card readers for MP3 files (up to 32 GB), AUX-IN connection, arrow display in driver information system, including aerial, 7 speakers and 5-channel amplifier with a total output of 140 watts, connection to Audi music interface possible

S

■ Driver information system

with high-resolution display in white, improved gear indicator; shows: auto-check control, digital speedometer display, radio frequency, 2 adjustable speed warning thresholds, outside temperature, on-board computer, lap timer, as well as monitor for doors, engine compartment cover and luggage compartment lid

S

Radio systems

■ Concert radio

with single CD player (MP3-compatible), 6.5-inch TFT colour screen, FM (UKW) and AM (MW, LW) reception, 2 slots for MMC/SD memory cards for playing MP3 files, 7 speakers and 5-channel amplifier with a total output of 140 watts, including AUX-IN port in the centre console for connecting audio end devices

S

■ Bang & Olufsen Sound System

surround sound reproduction via 12 speakers; centre speaker on the instrument panel, 1 midrange speaker and 1 woofer in each door, and 1 tweeter in mirror mount; 1 woofer and tweeter in the rear side panelling on each side; subwoofer; dynamic driving noise compensation; 10-channel amplifier with a total output of 465 watts

NC

■ CD changer

in storage compartment, for 6 CDs, vibration-proof, easily accessible. CDs can be loaded and changed individually. Not in combination with AMI

£70.00

■ Audi music interface

for the connection of Apple iPod from generation 4, Apple iPhone (music functionality) as well as USB storage media and MP3 players. Operated via the concert radio, the navigation system plus or the R8 GT multi-function sports steering wheel. Note: can only be used with a special adapter cable (available from Audi Genuine Accessories). Please contact your Audi partner for information on compatible MP3 players

S

■ Adapter cable set for Audi music interface

consisting of 2 cables for connecting an iPod/iPhone or data storage device/media player with USB port (type A); further adapter cables available via Audi Genuine Accessories

S

Telephone and communication

■ Bluetooth interface

including belt microphone; Bluetooth-capable mobile phones can be connected to the vehicle via the interface. Hands-free calls in the vehicle possible via microphone

S

Assistance systems

■ Parking system plus

acoustic and visual park assist system for the front and rear with display of symbols on the screen to indicate distance from an obstacle; measurement is by ultrasonic sensors concealed discretely in the bumpers

S

■ Cruise control system

maintains the desired speed above around 25mph, provided engine power output and engine braking effect permit; operation via separate steering column stalk

£220.00

■ Audi hill-hold assist

Prevents roll-back on hills for up to 5 seconds by maintaining brake force

S

NC - No cost

S - Standard

Suspension/brakes

■ Sports suspension

with more stiffly tuned spring and damper set-up; body lowered by approx. 10 mm

S

■ Ceramic brakes

brake discs made from Carbon fibre-reinforced ceramic, with specially developed cooling channels, internally ventilated and perforated with a floating mounting; 6-piston monoblock aluminium callipers at front, 4-piston fixed-calliper brakes at rear; brake callipers front and rear in anodized red with “Audi ceramic” inscription. For excellent braking performance, fade resistance and durability

S

Technology/safety

■ Fullsize airbags

for driver and front passenger

S

■ Audi Space Frame (ASF) body

innovative, high-strength combination of aluminium and magnesium materials for superior driving dynamics and handling stability; hood compartment lid and side sections at the rear made from carbon fibre-reinforced polymer (CFRP) for further weight savings combined with high rigidity

S

■ Seat belts

3-point automatic for driver and front-passenger seat, with belt tensioners and belt force limiters

S

■ Audi exclusive seat belts

in Titanium grey or crimson red. (Note: deletes Bluetooth interface)

£900.00

■ Instrument cluster

with white dials and R8 GT logo; including adjustable lighting, coolant and outside temperature display, rev counter with digital clock and date display, speedometer with disproportional display, odometer/trip recorder, fuel gauge, warning and indicator lights, service interval display, oil temperature, battery display

S

■ R tronic

6-speed sequential gearbox with shift-by-wire technology and sports mode

S

■ quattro®

permanent all-wheel drive for increased traction and driving safety, electronic differential lock EDL via braking intervention on all driven wheels

S

Audi warranty

■ Audi warranty

can be ordered directly and exclusively when you purchase a new vehicle and consistently continues the manufacturer's warranty. Choice of either 4 years, 75,000 miles or 5 years, 90,000 miles whichever comes soonest

4 years or 75,000 miles £1,035.00

5 years or 90,000 miles £2,555.00

NC - No cost

S - Standard

Model	R8 GT Spyder
Engine type	V10 petrol engine with direct fuel injection
Displacement in cc (valves per cylinder)	5204 (4)
Max. power ¹ in PS* at rpm	560/8000
Max. torque in Nm at rpm	540/6500
Power transmission/wheels	
Type of drive	quattro® permanent all-wheel drive
Transmission	sequential 6-speed manual transmission R tronic
Wheels	Forged aluminium wheels, size 8.5 J x 19 at front, 11 J x 19 at rear
Tyres	235/35 R 19 at front, 295/30 R 19 at rear
Weight/capacities	
Unladen weight ² in kg	1715
Gross vehicle weight in kg	1940
Fuel tank capacity approx. in l	80

Performance/consumption³

Top speed in mph	197						
Acceleration 0–62mph in seconds	3.8						
Fuel grade	SuperPlus sulphur-free RON 98 ⁴						
Fuel consumption ⁵ in mpg (l/100km)	<table border="0"> <tr> <td>urban</td> <td>13.1 (21.5)</td> </tr> <tr> <td>extra-urban</td> <td>27.7 (10.2)</td> </tr> <tr> <td>combined</td> <td>19.9 (14.2)</td> </tr> </table>	urban	13.1 (21.5)	extra-urban	27.7 (10.2)	combined	19.9 (14.2)
urban	13.1 (21.5)						
extra-urban	27.7 (10.2)						
combined	19.9 (14.2)						
CO ₂ emissions ⁵ in g/km	<table border="0"> <tr> <td>combined</td> <td>332</td> </tr> </table>	combined	332				
combined	332						
Emission standard	EU5						

Specification of the R8 GT Spyder illustrated here:

Paint finish: Sphere blue, matt effect with hood in black;

Wheels: Forged aluminium wheels of 5 double-spoke Y design in titanium look;

Seats/seat upholstery: Audi exclusive sports bucket seats body-coloured upholstered in Alcantara, black with piping and contrasting seams in titanium grey

Notes

- ¹ The figure given has been calculated in accordance with the specified measuring procedure (current version of Directive 80/1269/EEC).
- * Please note: The maximum power output figures are quoted in PS (or Pferdestärke, which is the metric equivalent of brake horsepower). To convert to brake horsepower, divide the PS figure by 1.0139.
- ² Weight of car, unladen, with driver (68 kg), luggage (7 kg) and fuel tank 90 % full, calculated in accordance with the current version of Directive 92/21/EEC. Optional equipment may increase the car's unladen weight and drag coefficient, whereupon the possible payload limit and the top speed will be reduced accordingly.
- ³ A vehicle's fuel consumption and CO₂ emissions do not just depend on how efficiently the vehicle uses the fuel, but are also influenced by driving behaviour and other non-technical factors. CO₂ is the greenhouse gas primarily responsible for global warming.
- ⁴ We recommend using sulphur-free SuperPlus unleaded fuel RON 98 in accordance with DIN EN 228. If not available: sulphur-free super unleaded fuel RON 95 in accordance with DIN EN 228; power output will be slightly reduced. Unleaded RON 95 fuel with a maximum ethanol content of 10 % (E10) can generally be used. Fuel consumption details refer to operation with RON 95 fuel in accordance with 692/2008/EC.
- ⁵ The figures given were calculated using the specified measuring procedures. The figures do not refer to one individual vehicle and do not form part of any offer, but rather should be used purely for purposes of comparison between the different vehicle models.

Important note

Inspections are due as shown by the service display.

Audi R8 GT Spyder

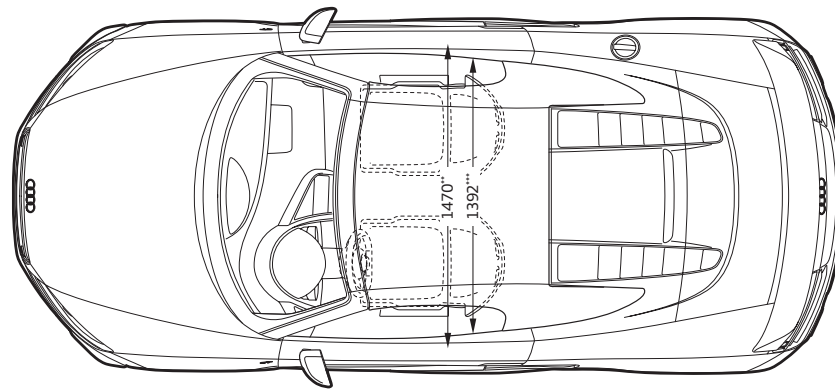
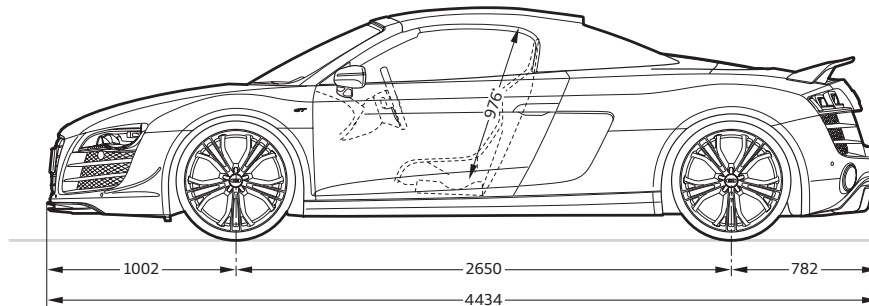
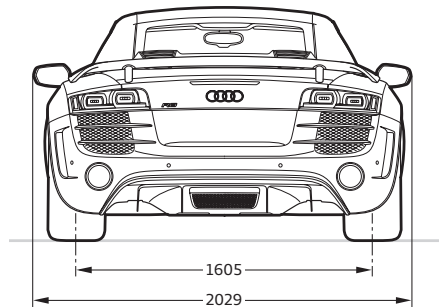
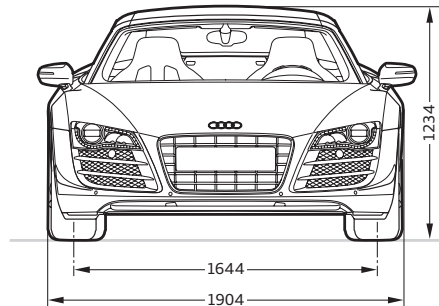
**Dimensions in millimetres.**

Dimensions were measured with vehicle at unladen weight.

Luggage compartment volume in l: 100 (measured by the VDA method using 200 x 100 x 50 mm blocks).

Turning circle approx. 11.8 m. *Maximum headroom. **Elbow room width. ***Shoulder room width.

