



The Audi R8 Coupé and Spyder

Pricing and Specification Guide

Valid from May 2013

Personalising your Audi R8

This guide has been designed to help you tailor and price your Audi R8 quickly and logically. At the back, you will find information on CO2 emissions-based taxation and the other services offered by Audi, including Finance and Insurance. You can also configure your Audi R8 online at audi.co.uk.

Audi Vision

To accompany this printed guide, we've created Audi Vision – an intuitive app that lets you find out even more about the Audi R8. Compatible with Apple and Android phones and tablets, Audi Vision gives you exclusive access to images, information and video content – all of which is designed to help you explore and understand the options available with this model.

You'll see the Audi Vision logo printed next to the page number on pages throughout this guide and wherever you do, you'll be able to view additional content on that page.



The Audi R8

Engine	14
Transmissions	15
Technology	16

Model details and prices

R8 V8 model equipment	20
R8 V10 model equipment	22
R8 V10 plus model equipment	24
Model prices	26

Colour and upholstery

Paint	28
Hood colours	36
Upholstery	38
Colour and trim guide	44

Audi exclusive	46
-----------------------	----

Inlays	54
---------------	----

Options

Wheels, brakes and suspension	58
Audio and communication	62
Interior equipment	64
Luggage sets	66
Exterior equipment	67
Safety and security	68
Steering wheels	69
Factory Collection from Neckarsulm	70
R8 Driving Experience	71

Looking after your Audi

Audi Complete and Warranty	72
Merchandise	75
Audi Difference	76

Technical details

Technical data	77
Dimensions	79
Pricing and Additional information	83





Vorsprung durch Technik

Three words that express the very essence of Audi. Vorsprung durch Technik isn't a slogan. It's our way of seeing the world. It is the driving force behind our history of innovation that continues into the 21st century. Indeed, many technologies that Audi pioneered remain in our cars today. Some are milestones in the history of the motorcar.

From our beginnings in 1899, to the Auto Union team's Grand Prix successes in the 1930s and our more recent wins at Le Mans, we have always been at the forefront of the motor industry.

Vorsprung durch Technik makes us who we are. To see more of its influence, just read on.

The R8 heritage

Audi has always enjoyed an enviable track record in the world of motorsport. An unrivalled combination of passion, determination, expertise and Vorsprung durch Technik has helped propel the four rings of Audi past finishing line after finishing line. With the introduction of the revolutionary quattro® all-wheel-drive technology in the early 1980s came a run of victories that will never be forgotten. And thanks to a continuing dedication to innovation and progression, that success has continued right through to the present day.

In 1999, Audi entered Le Mans for the first time. Since then, it has won the legendary endurance race again and again. It is in recognition of this unprecedented success that the Audi R8 was created – a car that has much more in common with the Le Mans-winning racer than simply a name.





Design and performance

Every detail of the R8's exterior immediately marks it out as a progressive sports car: from the emphatic, structural shape, wide air intakes and sweeping sideblades, to the retractable rear spoiler. But these design features aren't just for show. Each serves its own purpose, whether enhancing the car's aerodynamic potential or cooling the engine which sits directly behind the cockpit. And that's no easy task. Both the 4.2 V8 and 5.2 V10 powerplants are extremely high-revving, with breathtaking performance thanks to FSI® direct petrol injection and quattro® all-wheel-drive. Enabling you to get the most from them are a number of auxiliary technologies – a lightweight aluminium crankcase, quick-shifting S tronic 7-speed gearbox and optional Audi magnetic ride.

Inside its rigid yet lightweight aluminium Audi Space Frame®, the R8 has more than a hint of racing car inspiration in its layout and appearance, with Fine Nappa leather Sports seats, driver-oriented instruments and a leather, flat-bottomed steering wheel as standard. The perfect setting to enjoy some impressive technologies, including the optional Audi parking system advanced and the 465-watt 12-speaker Bang & Olufsen surround sound system – if the arresting symphony of the R8's engine wasn't enough. Read on to discover more about the revolutionary Audi R8, including standard and optional equipment, paint colours and prices.

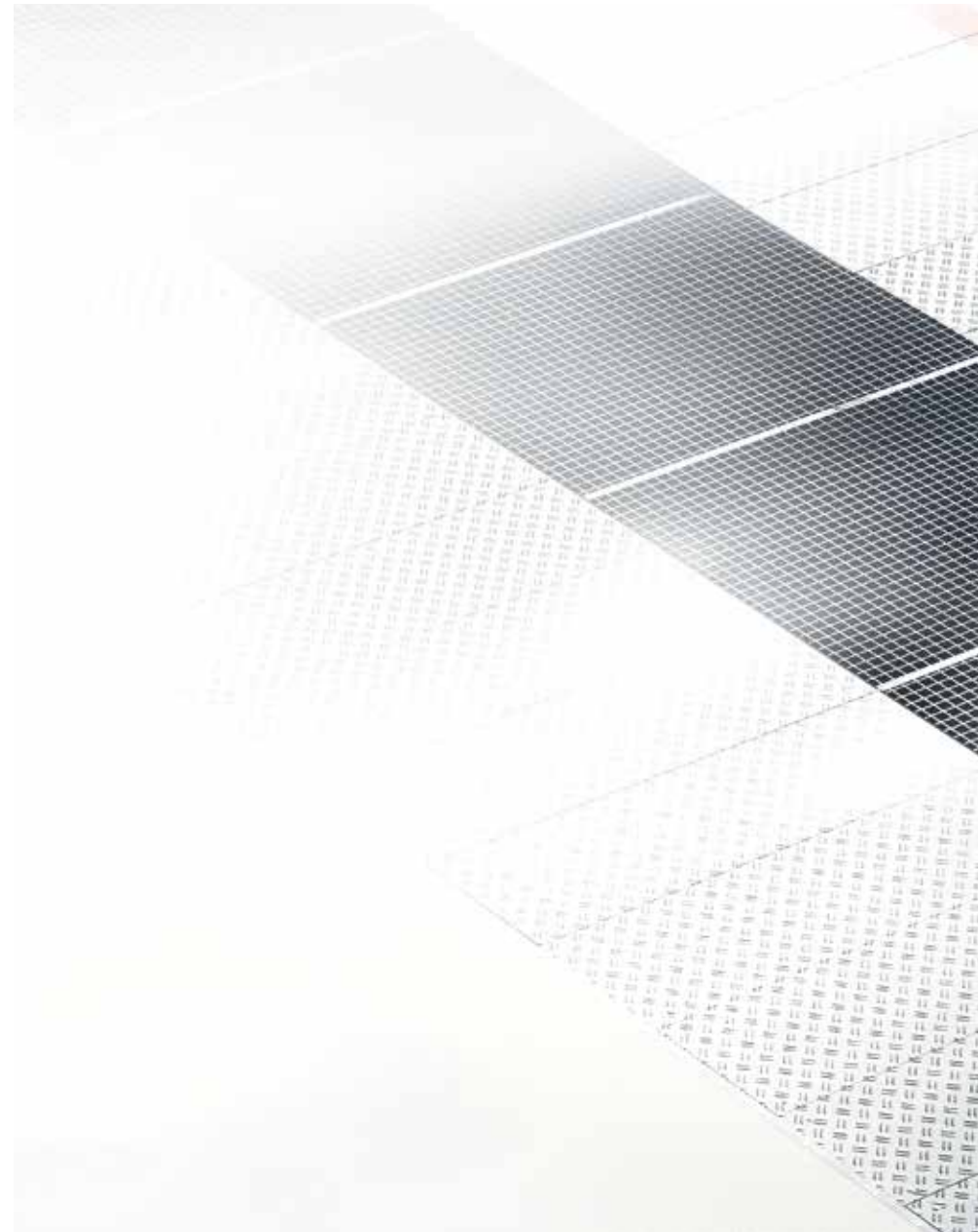



The R8 craftsmanship

The Audi R8 is built on a small production line in a specially constructed block at the Audi factory in Neckarsulm, Germany. The entire production process – from the bodyshell construction to final assembly – is organised in the same way as it would be in a craft workshop. Small teams of specialists oversee every step of production, subjecting each part and component to intense scrutiny. This ensures that every one of the maximum 29 cars built each day will more than meet the high standards of the Audi product range.





R8 interior story

We've introduced a number of finishing touches to the Audi R8 interior to make your driving experience both comfortable and unique. You'll find an impressive attention to detail in everything from the luxurious leather seating to our optional customised stitching, which means that every journey you make will be a personal one.





Engine

FSI® direct-injection technology is a unique Audi innovation that was originally developed for the Le Mans 24-hour endurance race to deliver more power and torque, as well as enhanced fuel efficiency. Precisely the right amount of fuel and air are injected into the combustion chambers, enabling the engine to 'breathe' more easily. It results in reduced heat loss and increased output, with around a 15% reduction in fuel consumption and significantly lower exhaust emissions.





Transmissions

Manual

By specifying a 6-speed manual transmission for your Audi R8, you'll put yourself in complete control of your driving experience. The system is matched precisely to the Audi R8's engine configuration and driving dynamics, allowing you to take full advantage of the broad spread of torque available across six closely spaced gear ratios. Compact and lightweight, the manual system is a simple, direct way to tap into the R8's power. A gated system provides short gearshift travel and precise lever movement, giving you the highest possible level of accessibility with the minimum of fuss.

S tronic®

Driving is all about thinking ahead, which is just what the S tronic® dual-clutch transmission does. It works almost as two separate systems, one engaging the odd-numbered and the other the even-numbered gears. So when you're accelerating in second, it has third gear waiting for you. And once you make the switch, it's already thinking about fourth. With two clutches working together, you can change gears almost instantly while experiencing smooth, uninterrupted power.

Technology

quattro®

It's the technology that has given Audi the edge on the rally circuit ever since it was first introduced over 30 years ago – a technology that delivers ultimate control whilst enhancing the sporty characteristics which make the Audi R8 so thrilling to drive. It's called quattro® all-wheel-drive. The principle is simple: in the same way that four brakes ensure better deceleration, four permanently-driven wheels deliver better acceleration and road-holding, pushing or pulling the car as needed, for a driving experience that's both dynamic and safe.

In the Audi R8 asymmetric dynamic torque distribution continuously distributes drive power between the front and rear axles depending on weather conditions, road surface and gradient, which increases flexibility for an enhanced, sportier drive.

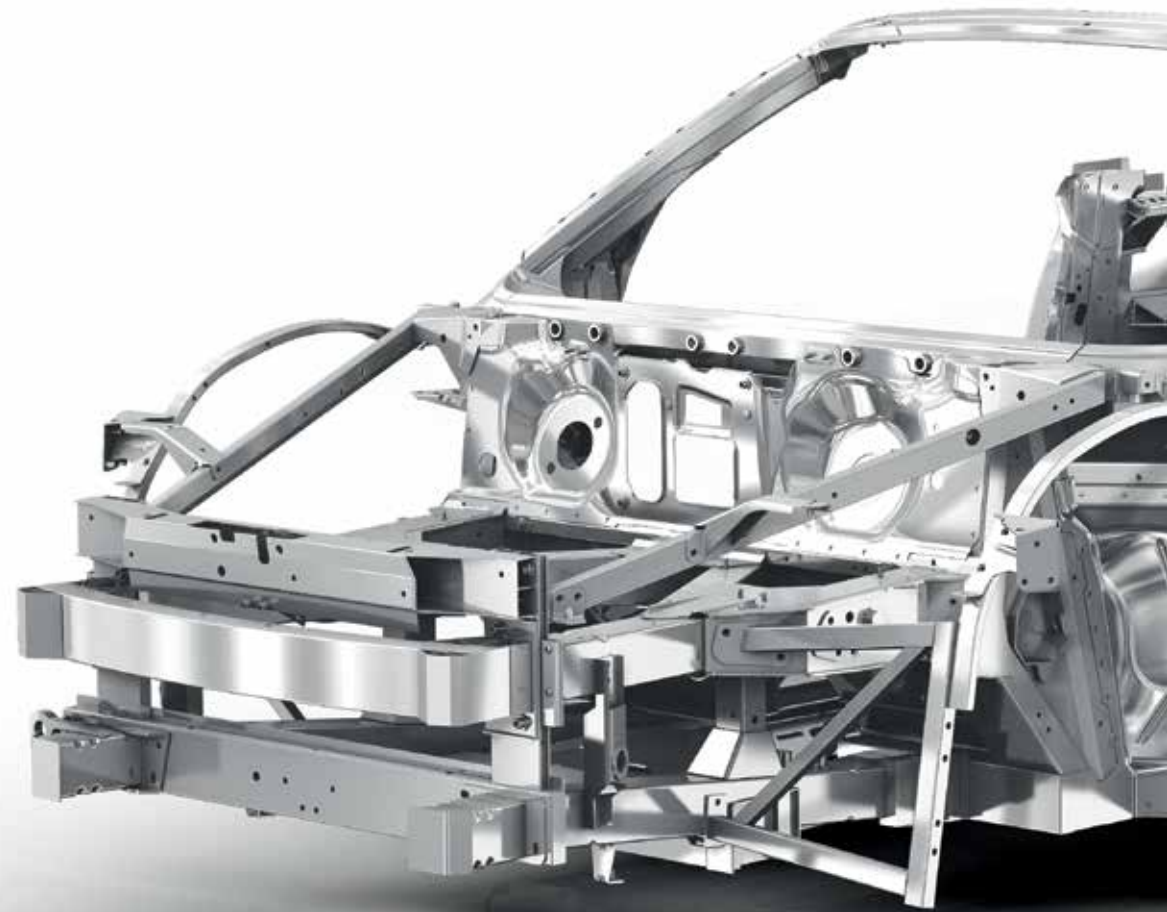

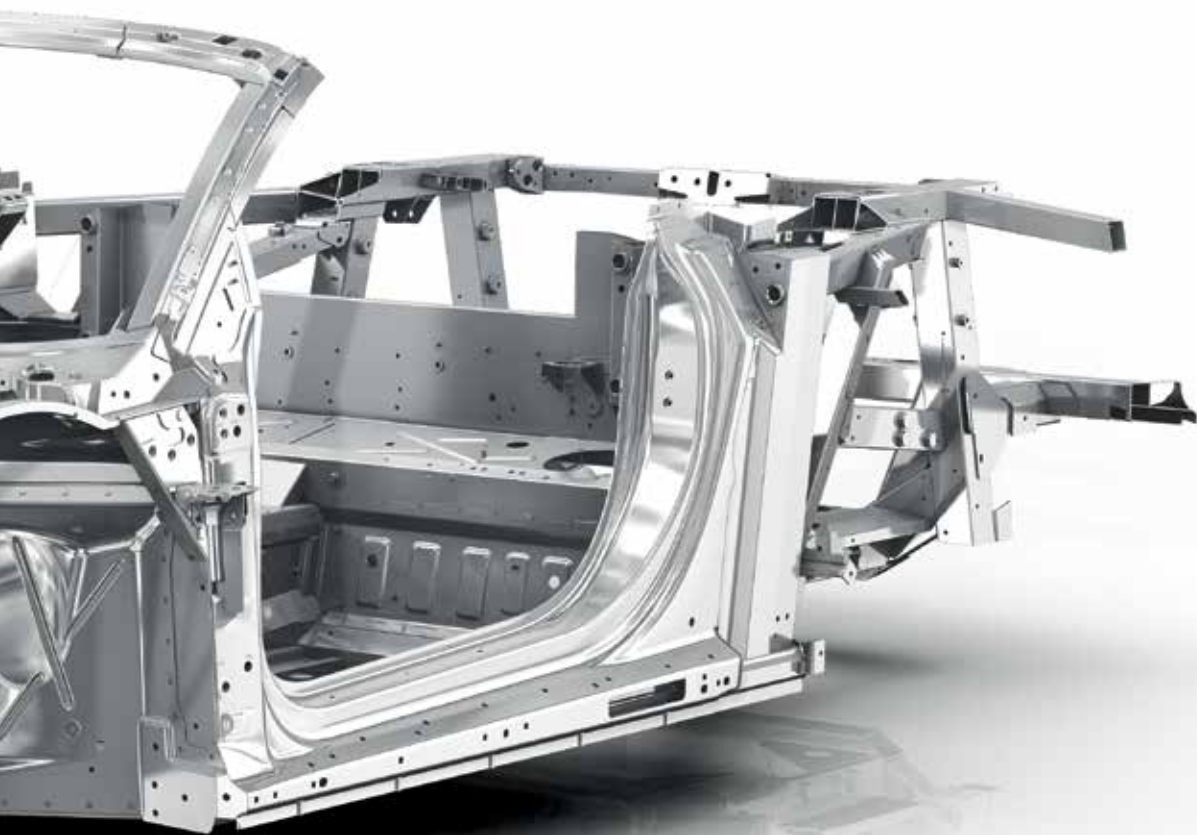

Audi Space Frame®

The Audi R8 is built using a unique Audi Space Frame®, which was introduced in 1994 and is both lightweight and extremely strong. It ensures that performance doesn't come at the expense of safety, as the car's body remains tough and beautifully balanced.

Fabric hood

The innovative Z-folding fabric hood of the Audi R8 Spyder is made from an advanced material which is lightweight and flexible. It automatically opens and closes in 19 seconds, with just one touch. Better still, it can operate at speeds of up to 31mph, so you won't have to stop your journey. When lowering, it folds neatly beneath the cover of its compact storage compartment which sits just above the powerful engine.

Mid-mounted engine

The Audi R8's engine is mid-mounted, which gives it a low centre of gravity and helps it to achieve the ideal weight balance. The axle load distribution of 44:56* ensures high directional stability and superb road behaviour.

*R8 Coupé models only





R8 V8 model equipment

All Audi R8 V8 models have the following items of standard equipment

Wheels, tyres and suspension

19" '5-arm double-spoke' design alloy wheels, 19 x 8.5J front and 19 x 11J rear with 235/35 and 295/30 tyres

Locking wheel bolts

Tyre repair kit

quattro all-wheel-drive

Sports suspension with dynamically tuned spring and damper combination

Audio and communication

Concert radio with single front-loading CD player and MP3 file compatibility with active front and rear speakers

Mobile telephone preparation – Bluetooth interface with integrated seatbelt microphones and voice control. Provides handsfree connection via Bluetooth using mobile phone aerial, and voice control via the microphones integrated into the driver and passenger seatbelts. Please contact your Audi Centre for phone compatibility

Audi Music Interface. Provides connection for use with USB storage devices and MP3 players, including Apple iPod generation 4 onwards and Apple iPhone. Replicates display on the audio screen and DIS, including track titles. Interface is housed in the rear shelf between seats, and provides a charging function (dependent on device). Intuitive operation via the audio system or multi-function steering wheel

Satellite Navigation system – DVD-based. Route planning and guidance using voice, pictogram and 3D mapping. 5-digit postcode recognition. Includes AM/FM tuner with TP memo function. Single front-loading CD/DVD player with MP3-compatibility, suitable for audio and DVD playback. Includes MMI operating logic and high resolution (800x480) 6.5-inch colour TFT display, with bird's-eye map display, two integrated SD card readers, European coverage navigation DVD and dynamic route guidance via TMC

Seats

Sports seats

Electric lumbar support

Heated seats

Safety and security

Anti-lock Braking System (ABS)

Anti-Slip Regulation (ASR)

Anti-theft alarm and electronic immobiliser

Brake lights with LED technology

Wave brake discs – internally ventilated with 8-piston brake callipers at front and 4-piston at rear

Driver, front passenger and front side airbags

Electronic Differential Lock (EDL) traction control



19" '5-arm double-spoke' design alloy wheels



Retractable rear spoiler



All-LED headlights



Satellite Navigation – DVD based

Electronic Stability Control (ESC) with sports mode. Latest generation ESC version 8.0 networks the ABS, EBD (Electronic Brake Force Distribution), ASR and EDL systems, and ensures greater stability at all speeds by braking individual wheels as required and overriding the engine-management system. Driver can select different ESC settings to suit different driving conditions

First-aid kit with warning triangle

ISOFIX with front-passenger airbag deactivation switch

Remote central locking

Seatbelt reminder

Tool kit

Exterior equipment

Audi hill-hold assist

Dual-branch round tailpipes in chrome finish

Door mirrors – electrically operated and heated

Electrically retractable, heated glass rear window (Spyder only)

Exterior lighting, including exit lights

Retractable rear spoiler – deploys and retracts automatically at set speeds, or can be operated manually via button in centre console

All-LED headlights. LEDs for all front lighting functions. LED technology provides lower energy consumption and enhanced contrast, with a colour similar to daylight, for increased safety and good recognition by other road users. Includes turning light function which is activated via the steering angle or when indicator is switched on (up to speeds of 45mph). Also includes rear LED indicators with sweeping indicator function

Fully automatic acoustic hood with one-touch operation (Spyder only)

Interior equipment

3-spoke flat-bottomed leather-covered multi-function steering wheel (with gear-shift paddles for S tronic transmissions)

Aluminium gear knob and lever gate

Cup holder – two compartments integrated into centre console

Driver's Information System (DIS)

Electronic climate control

Fine Nappa leather upholstery, for seats and headrests, radio surround, centre console including knee bolster, lower door inserts and door handle on passenger side

Heated engine partition window

Inlays in matt silk finish, black – upper trim on centre console, centre inlay and door inlay

Interior and instrument lighting

Lockable glove box with light

Roof lining in black

Door sill trims in aluminium with R8 logo

Sun visors with vanity mirror

Wind deflector (Spyder only)

Audi R8 Driving Experience

Please see page 71 for further details



Aluminium gear knob and lever gate



3-spoke flat bottomed leather-covered multi-function steering wheel



Instrument cowl and dials



Door sill trims in aluminium with R8 logo

R8 V10 model equipment

In addition to R8 V8 standard model equipment

Wheels, tyres and suspension

19" '10-spoke Y' design alloy wheels, 19 x 8.5J front and 19 x 11J rear with 235/35 and 295/30 tyres

Audi magnetic ride. Adaptive suspension system with two selectable modes (Normal and Sport). Sensors in the car monitor the road conditions and adjust the damping effect by varying a magnetic charge which passes through a fluid-based shock absorber, delivering improved road handling, outstanding chassis control and excellent driving comfort

Audio and communication

Bang & Olufsen sound system. Designed specifically for the Audi R8, providing surround sound reproduction with dynamic compensation for road noise, digital amplifier and 12 high-performance loudspeakers (total output 465 watts)

Safety and security

Tyre pressure monitoring system

Paint

Metallic or pearl-effect

Exterior equipment

Auto-dimming and folding door mirrors

Light and rain sensor package. Includes auto-dimming rear-view mirror and door mirrors, automatic headlight activation and automatic windscreen wipers. Also includes electrically folding door mirrors

V10 badges on front wings (and engine bay on R8 Coupé)

Interior equipment

Electrically adjustable seats

Extended Fine Nappa leather package. Includes Fine Nappa leather for dashboard, top shoulder and side panel, storage compartment in doors, monoposto, instrument cowl, knee bolster and function pads

Light package including LED lights illuminating footwell (and engine compartment on Coupé)

Stainless steel pedals with black rubber inserts



19" '10-spoke Y' design alloy wheels



Bang & Olufsen sound system



Stainless steel pedals with black rubber inserts



Image shows R8 V10 Coupé model with optional Panther black, crystal effect paint (H8) and sideblades in Oxygen silver (6H2)

R8 V10 plus model equipment

In addition to, or in replacement of, R8 V8 standard model equipment

Wheels, tyres and suspension

19" '5-arm double-spoke Y' design alloy wheels, 19 x 8.5J front and 19 x 11J rear with 235/35 and 295/30 tyres

Ceramic brakes. Lightweight, ventilated ceramic brake discs to all four wheels, 380mm discs at front, 356mm at rear, 6-piston monobloc anthracite-coloured brake callipers with 'Audi ceramic' inscription on front callipers

V10 plus Sports suspension with stiffer spring and damper combination for more direct road contact and sportier handling

Seats

R8 bucket seats.* Bucket seats in Fine Nappa leather with R8 embossing. Includes electric lumbar-support adjustment (horizontal and vertical), width adjustment for seat surface and backrest, and manually adjustable seat height, longitudinal positioning and backrest angle

Safety and security

Tyre-pressure monitoring system

Paint

Metallic or pearl-effect

Exterior equipment

Front spoiler lip and rear diffuser in Carbon sigma

Door mirrors in Carbon sigma

Sideblade in Carbon sigma

Dual-branch round tailpipes in polished black

V10 badges on front wings and engine bay

V10 plus styling – comprising radiator-grille frame in matt titanium grey, with grille in matt black. Number-plate holder and air inlets and outlets on front and rear bumpers in matt titanium grey

Interior equipment

R8 3-spoke contoured flat-bottomed multi-function Sports steering wheel in perforated leather. More heavily contoured and ergonomic steering-wheel rim in perforated leather with R8 badge (with gear shift paddles for S tronic transmissions)

Inlays in Carbon sigma

Light package including LED lights illuminating footwell and engine compartment

Stainless steel pedals with black rubber inserts

Auto-dimming rear-view mirror



19" '5-arm double-spoke Y' design alloy wheels



Door mirrors in Carbon sigma



R8 bucket seats



Rear diffuser and polished black tailpipes



Image shows R8 V10 plus Coupé model with optional 19" '5-arm double-spoke Y' design alloy wheels in high-gloss black finish (PQM)

R8 Coupé

Engines	Power	Transmissions	CO ₂ g/km	Basic RRP	Total RRP inc VAT	Recommended OTR
4.2 FSI quattro	430PS	6-speed manual	332	£75,833.33	£91,000.00	£92,710.00
4.2 FSI quattro	430PS	7-speed S tronic	289	£78,250.00	£93,900.00	£95,610.00
5.2 FSI quattro	525PS	6-speed manual	346	£93,416.67	£112,100.00	£113,810.00
5.2 FSI quattro	525PS	7-speed S tronic	305	£95,833.33	£115,000.00	£116,710.00

R8 V10 plus

Engines	Power	Transmissions	CO ₂ g/km	Basic RRP	Total RRP inc VAT	Recommended OTR
5.2 FSI quattro	550PS	6-speed manual	346	£103,416.67	£124,100.00	£125,810.00
5.2 FSI quattro	550PS	7-speed S tronic	299	£105,833.33	£127,000.00	£128,710.00

R8 Spyder

Engines	Power	Transmissions	CO ₂ g/km	Basic RRP	Total RRP inc VAT	Recommended OTR
4.2 FSI quattro	430PS	6-speed manual	337	£83,041.67	£99,650.00	£101,360.00
4.2 FSI quattro	430PS	7-speed S tronic	294	£85,458.33	£102,550.00	£104,260.00
5.2 FSI quattro	525PS	6-speed manual	349	£100,625.00	£120,750.00	£122,460.00
5.2 FSI quattro	525PS	7-speed S tronic	310	£103,041.67	£123,650.00	£125,360.00

Please note: The maximum power output figures are quoted in PS (or Pferdestärke, which is the metric equivalent of brake horsepower). To convert to brake horsepower, divide the PS figure by 1.0139.

Recommended On-The-Road (OTR) retail prices include: delivery charge, half a tank of fuel, number plates at £590.00 (inc. VAT), Road Fund Licence (which may vary depending on model/transmission – see page 84 for details) and first registration fee at £55.00. Vehicle Excise Duty correct at time of going to print, but this may alter to reflect any change in the applicable VED rate.

RRP – Recommended Retail Price. VAT is calculated at 20% but this may alter to reflect any change in the applicable VAT rate.





Paint

We believe that every part of your car should have a personal touch. Which is why you can choose from a wide range of paint colours and finishes, from standard shades to metallic and pearl effects. We can even mix a customised colour for you to create the perfect fit.

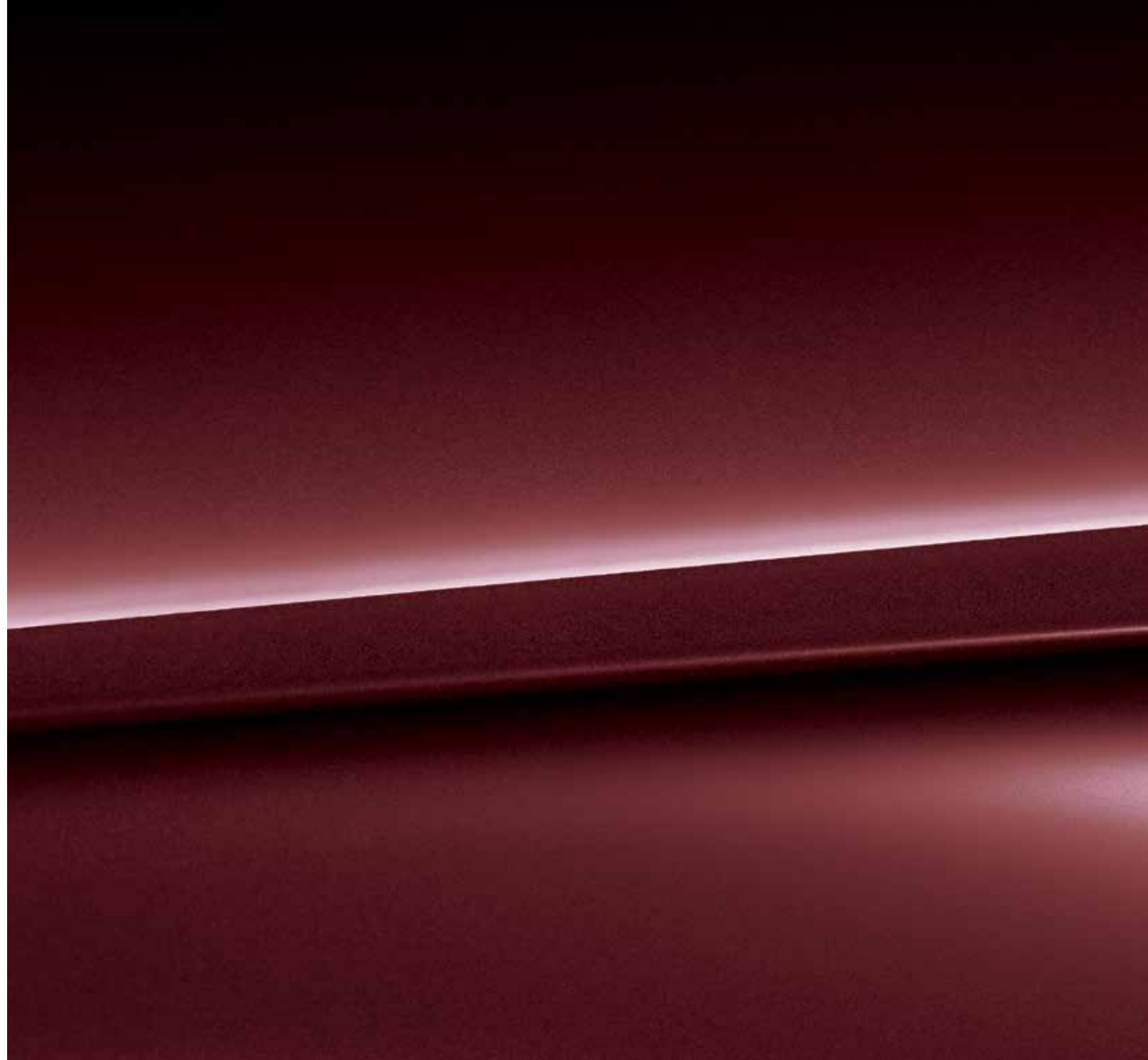

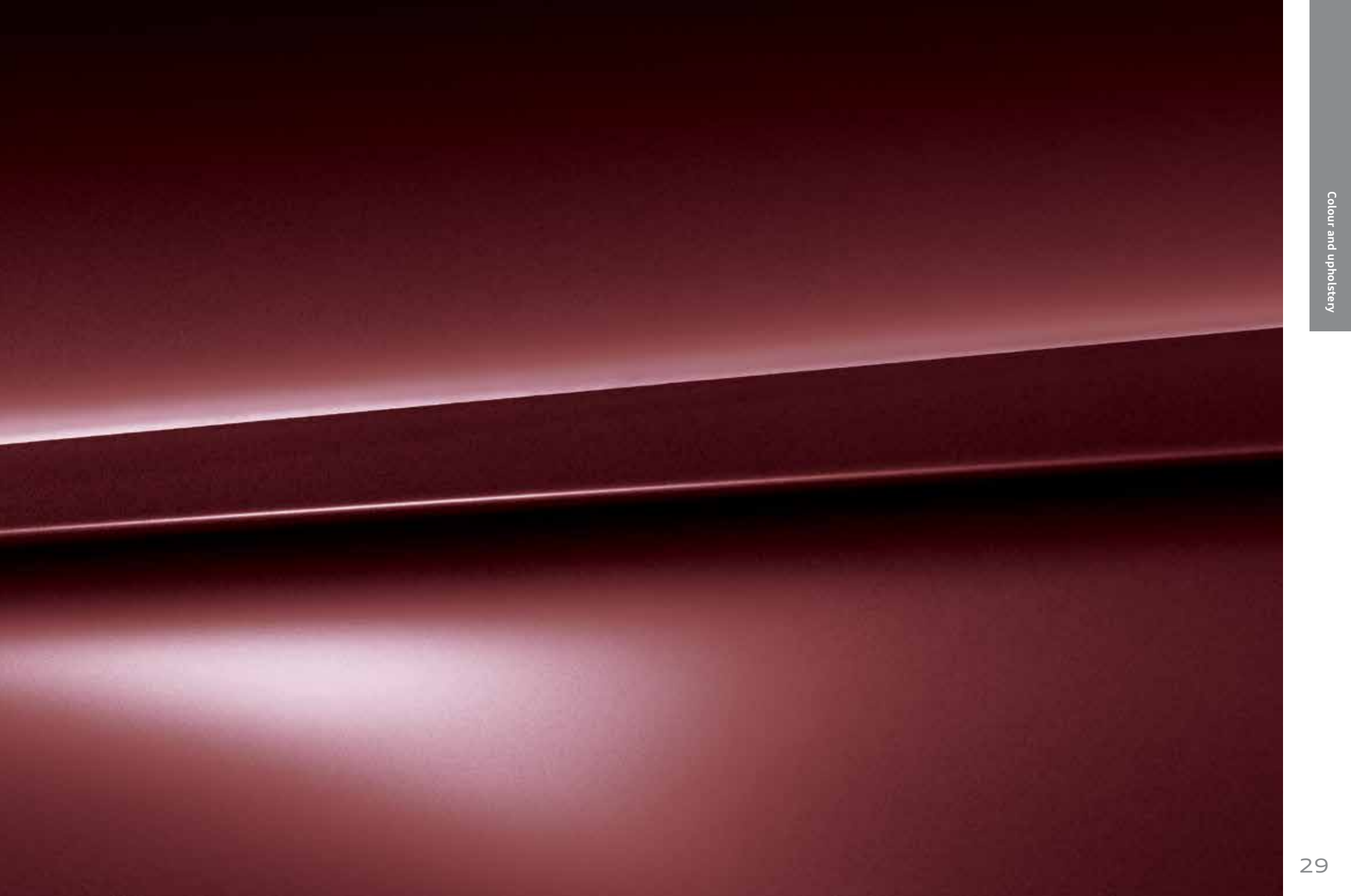

Paint

R8 Coupé

To create your ideal R8, just choose one of the colours opposite. To individualise your R8 Coupé sideblades, please refer to page 35.

Standard colours



Ibis white
Ice silver sideblade – T9



Brilliant red
Brilliant red sideblade – C8

Optional colours



Ice silver, metallic
Apollo silver sideblade – P5

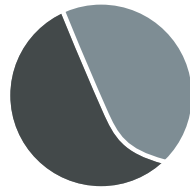

Daytona grey, pearl effect
Quartz grey sideblade – 6Y

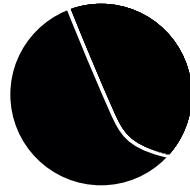

Panther black, crystal effect
Lava grey sideblade – H8



Suzuka grey, metallic
Ice silver sideblade – M1



Samoa orange, metallic
Quartz grey sideblade – J0

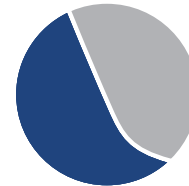

Estoril blue, crystal effect
Ice silver sideblade – K0

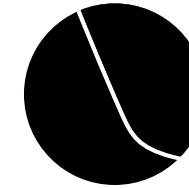

Phantom black, pearl effect
Lava grey sideblade – L8

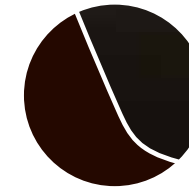

Teak brown, metallic
Saddle brown sideblade – 4U

V10 colour



Sepang blue, pearl effect
Mugello blue sideblade – E9

Options are subject to availability and may extend delivery.

All the colour swatches on this page are matched as accurately as possible to the actual paint colours used. However, due to print processes, Audi UK cannot guarantee that colours shown are 100% accurate.

Visit your local Audi Centre for a more accurate colour swatch.

RRP – Recommended Retail Price.

VAT is calculated at 20% but this may alter to reflect any change in the applicable VAT rate.

Optional colours

Basic RRP

R8 V8 – £595.83
R8 V10 – No charge

Total RRP inc VAT

R8 V8 – £715.00
R8 V10 – No charge

Optional colours

Crystal effect

Basic RRP

R8 V8 – £804.17
R8 V10 – £208.33

Total RRP inc VAT

R8 V8 – £965.00
R8 V10 – £250.00

V10 plus colour



Sepang blue, matt effect
Carbon sigma sideblade - 4R

V10 plus colour

Sepang blue, matt effect

Basic RRP

£3,125.00

Total RRP inc VAT

£3,750.00



Paint

R8 Spyder

Make sure your R8 Spyder looks exactly the way you want it by selecting one of the colours opposite.

Standard colours



Ibis white - T9

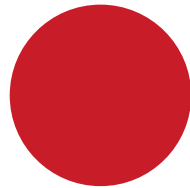

Brilliant red - C8

Optional colours

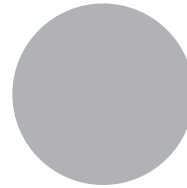

Ice silver, metallic - P5

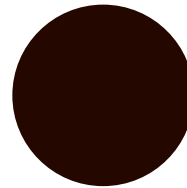

Teak brown, metallic - 4U

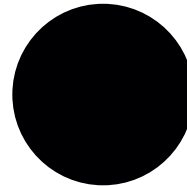

Panther black, crystal effect - H8

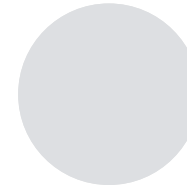

Suzuka grey, metallic - M1

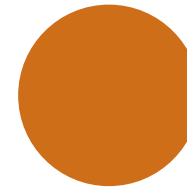

Samoa orange, metallic - J0

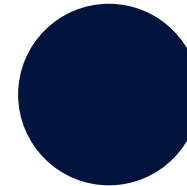

Estoril blue, crystal effect - K0

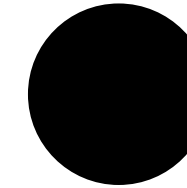

Phantom black, pearl effect - L8

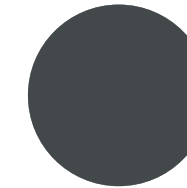

Daytona grey, pearl effect - 6Y

V10 colour

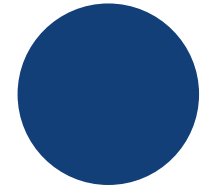

Sepang blue, pearl effect - E9

Options are subject to availability and may extend delivery.

All the colour swatches on this page are matched as accurately as possible to the actual paint colours used. However, due to print processes, Audi UK cannot guarantee that colours shown are 100% accurate.

Visit your local Audi Centre for a more accurate colour swatch.

RRP - Recommended Retail Price.

VAT is calculated at 20% but this may alter to reflect any change in the applicable VAT rate.

Optional colours

Basic RRP

R8 V8 - £595.83

R8 V10 - No charge

Total RRP inc VAT

R8 V8 - £715.00

R8 V10 - No charge

Optional colours Crystal effect

Basic RRP

R8 V8 - £804.17

R8 V10 - £208.33

Total RRP inc VAT

R8 V8 - £965.00

R8 V10 - £250.00



Paint

Audi exclusive

Everyone has a favourite colour. No matter what yours is, Audi exclusive provides a range of unique colours that have been designed to set your car apart. Choose from the swatches here or specify any other paint colour in the Audi range.

Customised

If you have a particular colour in mind, we'll mix the exact metallic or pearl-effect shade you want.*

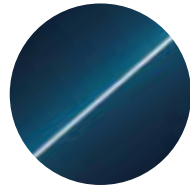

Palace blue, pearl effect

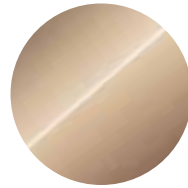

Sand beige, pearl effect

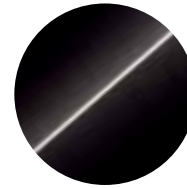

Saddle brown, pearl effect

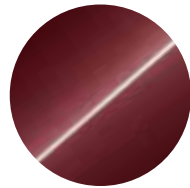

Classic red, pearl effect

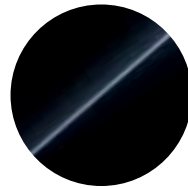

Mamba black, metallic

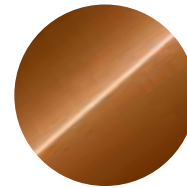

Ipanema brown, metallic



Any colour in the Audi range or 100 exclusive colours to choose from**



Customised paint

Options are subject to availability and may extend delivery.

*Customised paint is subject to factory approval, and is available for metallic and pearl-effect water-based paints only. Three-colour process colours and two-tone schemes are not available.

**Visit your local Audi Centre for colour samples.

All the colour swatches on this page are matched as accurately as possible to the actual paint colours used. However, due to print processes, Audi UK cannot guarantee that colours shown are 100% accurate.

RRP - Recommended Retail Price.

VAT is calculated at 20% but this may alter to reflect any change in the applicable VAT rate.

Audi exclusive

Basic RRP

V8 - £1,845.83

V10 - £1,250.00

Total RRP inc VAT

V8 - £2,215.00

V10 - £1,500.00

Customised*

Basic RRP

V8 - £2,262.50

V10 - £1,666.67

Total RRP inc VAT

V8 - £2,715.00

V10 - £2,000.00

Sideblades

The sideblades of the R8 Coupé are among its most distinctive design features. As an alternative to standard paint colours, you can customise your R8 Coupé even further by choosing from one of the options on the right.

Order Code		V8 Coupé	V10 Coupé	V10 plus	V8 Spyder	V10 Spyder	Basic RRP	Total RRP inc VAT
6H2	Oxygen silver	●	●	-	-	-	£708.33	£850.00
6H3	Carbon sigma	●	●	S	-	-	£1,500.00	£1,800.00

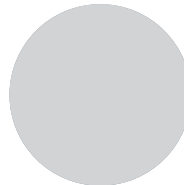

Oxygen silver sideblade - 6H2



Carbon sigma sideblade - 6H3

Order Code		V8 Coupé	V10 Coupé	V10 plus	V8 Spyder	V10 Spyder	Basic RRP	Total RRP inc VAT
YUY S3G	Sideblades in Audi exclusive paint or customised paint.* Not available in combination with sideblades in Oxygen silver (6H2) or Carbon sigma (6H3)**	●	●	●	-	-	£1,000.00	£1,200.00

Options are subject to availability and may extend delivery.

- = Not available
- = Available
- S = Standard

*The R8 Coupé sideblades are available in the Audi exclusive colours shown opposite.

**Please note this is only available in combination with sideblade tone-on-tone (6H0) on R8 V10 plus.

RRP - Recommended Retail Price.

VAT is calculated at 20% but this may alter to reflect any change in the applicable VAT rate.



Hood colours

The fully automatic acoustic hood is available in the colours opposite, so you can complement your car's interior and exterior.



Black hood – PA



Brown hood – PW

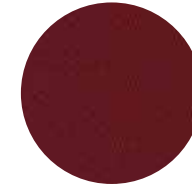

Red hood* – SF



Order Code		Black (PA)	Brown (PW)	Red (SF)
T9	Ibis white	•	•	•
C8	Brilliant red	•	–	–
P5	Ice silver, metallic	•	•	•
M1	Suzuka grey, metallic	•	–	•
4U	Teak brown, metallic	•	•	–
J0	Samoa orange, metallic	•	–	–
L8	Phantom black, pearl effect	•	•	•
6Y	Daytona grey, pearl effect	•	–	•
E9	Sepang blue, pearl effect	•	–	–
K0	Estoril blue, crystal effect	•	–	–
H8	Panther black, crystal effect	•	–	•

– = Not available
 • = Available
 S = Standard

*This option is subject to availability and may extend delivery. Please ask your local Audi Centre for further details.



Upholstery

It's important to feel comfortable on the road. Just choose from our range of luxury upholstery materials and textures, including additional support and colour options, for complete relaxation while you drive.





Upholstery and seats

Choose from a variety of different seat options so you can maintain the correct driving posture at all times.

Order Code	V8 Coupé	V10 Coupé	V10 plus	V8 Spyder	V10 Spyder	Basic RRP	Total RRP inc VAT
PS5	●	●	S	●	●	£2,083.33	£2,500.00
WLF PIE	-	-	●	-	-	No charge	No charge
PV1	●	S	-	●	S	£708.33	£850.00

R8 bucket seats.* Bucket seats in Fine Nappa leather with R8 embossing. Each includes electric lumbar-support adjustment (horizontal and vertical), width adjustment for seat surface and backrest, and manually adjustable seat height, longitudinal positioning and backrest angle. Only available in combination with interior colour black. Not available in combination with leather/Alcantara (N7U) or storage package (QE1)

Sports seats for R8 V10 plus. Front sports seats in Fine Nappa leather with prominent side bolsters for improved lateral support. Each includes 4-way electric adjustment for seat height, longitudinal positioning and backrest angle. Also includes lumbar support

Electrically adjustable seats. Each includes 4-way electric adjustment for seat height, longitudinal positioning and backrest angle. Also includes lumbar support. Not available in combination with R8 bucket seats (PS5)



Sports seat



R8 bucket seat

Options are subject to availability and may extend delivery.

- = Not available
- = Available
- S = Standard

Leather upholstery to seats, door trims and door handle on passenger side (all one colour).

*Please note the R8 bucket seats do not include side airbags or ISOFIX.



RRP – Recommended Retail Price.

VAT is calculated at 20% but this may alter to reflect any change in the applicable VAT rate.

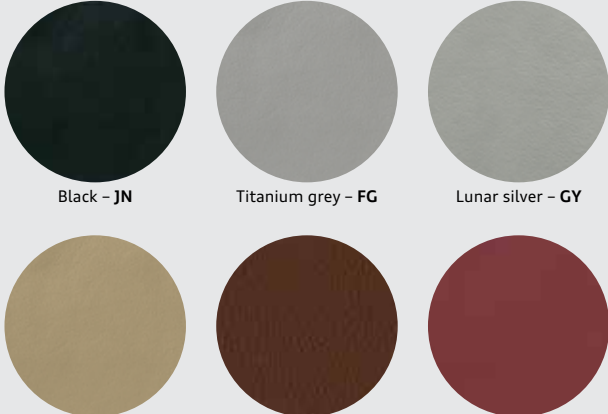
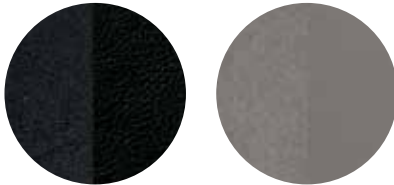

Upholstery

You can specify your R8's interior by choosing from the range of colours shown opposite.

	V8 Coupé	V10 Coupé	V10 plus	V8 Spyder	V10 Spyder	Basic RRP	Total RRP inc VAT	
Fine Nappa leather 	<p>Fine Nappa leather upholstery. For seats and headrests, radio surround, centre console including knee bolster, lower-door inserts and door handle on passenger side</p>					No charge	No charge	
	S	S	S	S	S			
	Leather/Alcantara (N7U) 							
	<p>Leather/Alcantara. Leather/Alcantara upholstery, including centre seat section in Alcantara and seat side sections and headrests in leather. Only available in combination with Sports seats (WLF/PIE) on R8 V10 plus</p>					No charge	No charge	
	•	•	•	•	•			
	Extended Fine Nappa leather package (PL3) 							
<p>Extended Fine Nappa leather package. Includes black Fine Nappa leather for dashboard, top shoulder and side panel, storage compartment in doors, monoposto, instrument cowl and function pads (please see page 57 for further details)</p>					£2,250.00	£2,700.00		
•	S	•	•	S				

Options are subject to availability and may extend delivery.

- = Not available
- = Available
- S = Standard

*Only available on R8 Coupé.

RRP - Recommended Retail Price.

VAT is calculated at 20% but this may alter to reflect any change in the applicable VAT rate.

Upholstery

Coloured stitching (OUB)

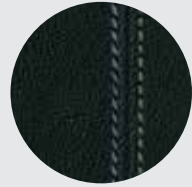

Black with Titanium grey stitching – FJ/FG

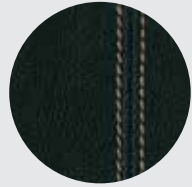

Black with Luxor beige stitching – EQ/TB/TQ

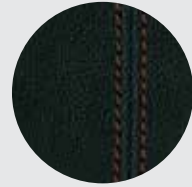

Black with Nougat brown stitching – FN/CZ

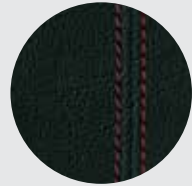

Black with Red stitching – ER/FL

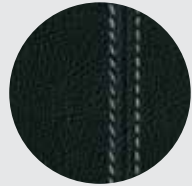

Black with Lunar silver stitching – EA/GY

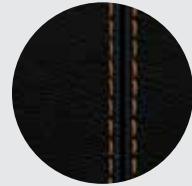

Black with Madras orange stitching – XF

Contrast stitching for Fine Nappa leather. Includes seats, monoposto, dashboard, instrument cowl, radio surround, centre console, handbrake grip and door-trim inserts. Only in combination with Extended Fine Nappa leather package (PL3) or Audi exclusive leather package 2 (PYD)*

Extended Fine Nappa leather package in stitched diamond design (PL8)

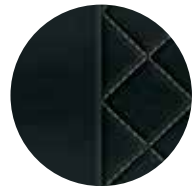

Black with Lunar silver stitching – XG

Extended Fine Nappa leather package in stitched diamond design.

Including Fine Nappa leather for dashboard, top shoulder and side panel, storage compartment in doors, monoposto, instrument cowl, knee bolster and function pads. Seat centre section and lower door inserts in stitched diamond design. Also includes contrast stitching for seats, monoposto, dashboard, cowl, radio surround, centre console, handbrake grip and door-trim inserts.* Only available in combination with Sports seats (WLF/PIE) on R8 V10 plus

	V8 Coupé	V10 Coupé	V10 plus	V8 Spyder	V10 Spyder	Basic RRP	Total RRP inc VAT
Coloured stitching (OUB)	●	●	●	●	●	£229.17	£275.00
Extended Fine Nappa leather package in stitched diamond design (PL8)	●	-	●	●	-	£3,083.33	£3,700.00
	-	●	-	-	●	£833.33	£1,000.00

Options are subject to availability and may extend delivery.

- = Not available
- = Available
- S = Standard

*It is recommended to order Audi exclusive leather-covered steering-wheel rim (YRH/S3G) with matching contrast stitching with this option.

RRP – Recommended Retail Price.

VAT is calculated at 20% but this may alter to reflect any change in the applicable VAT rate.

Colour and trim guide

Interior trim colours

To help choose the right interior for your new R8, please use this guide showing the carpet, dashboard and headlining colours that have been matched to your chosen upholstery.

Order Code	Upholstery	Carpet	Dashboard/seams	Headlining	Fine Nappa leather (PL1)	Leather/Alcantara (N7U)
JN	Black	Black	Black/Black	Black	●	●
FG	Titanium grey	Titanium grey	Black/Black	Black	●	●
TB	Luxor beige	Luxor beige	Black/Black	Black	●	—
TQ**	Luxor beige	Luxor beige	Black/Black	Luxor beige	●	—
GY	Lunar silver	Black	Black/Black	Black	●	—
FL	Red	Black	Black/Black	Black	●	—
CZ	Nougat brown	Black	Black/Black	Black	●	—

Coloured stitching (OUB or PL8)

Order Code	Upholstery	Carpet	Dashboard/seams	Headlining	Extended leather (PL3)	Extended leather (PL8)
FJ	Black	Black	Black/Titanium grey	Black	●	—
FN	Black	Black	Black/Nougat brown	Black	●	—
EQ	Black	Black	Black/Luxor beige	Black	●	—
ER	Black	Black	Black/Red	Black	●	—
EA	Black	Black	Black/Lunar silver	Black	●	—
FG	Titanium grey	Titanium grey	Black/Titanium grey	Black	●	—
TB	Luxor beige	Luxor beige	Black/Luxor beige	Black	●	—
TQ**	Luxor beige	Luxor beige	Black/Luxor beige	Luxor beige	●	—
GY	Lunar silver	Black	Black/Lunar silver	Black	●	—
FL	Red	Black	Black/Red	Black	●	—
CZ	Nougat brown	Black	Black/Nougat brown	Black	●	—
XG	Black	Black	Black/Lunar silver	Black	—	●

Options are subject to availability and may extend delivery.

*Only available on R8 Coupé.

*Only available in combination with Alcantara headlining (GNN or YSK).

— = Not available
● = Available
S = Standard



Audi exclusive

Audi exclusive enables you to create an Audi that's unique to you, with precisely the colours, finishes and interior detailing you want. You can customise as much or as little as you like, specify just one detail or design your car's overall appearance. It's entirely up to you.

Leather and stitching colours, inlays and carpets can all be tailored, and with hundreds of possible paint combinations we're sure to find the exterior colour you have in mind. We can even mix the exact metallic paint or pearlescent shade you want for your Audi.





Upholstery

Audi exclusive

With Audi exclusive, you can choose between Fine Nappa leather and leather/Alcantara, depending on the texture and flexibility you prefer in your car's upholstery. And once that's decided, you can specify your seat colour from an array of different options shown here.

Choose just one all-over shade for each seat, or customise each panel in two or more complementary colours from the distinctive Audi exclusive palette. You can even choose the colour of the decorative stitching – to match or contrast with your chosen upholstery – from this varied collection. Whatever combination you decide upon, we think you'll be extremely comfortable with the result.

Alcantara colours: available in all the Audi exclusive colours shown, except for Crimson red, Jet grey and Sand beige. Alcantara equivalents are Chilli red, Amethyst grey and Sesame beige, respectively.

Dashboard/monoposto: available in Havanna brown, Saddle brown, Chestnut brown, Classic red, Crimson red, Jet grey, Night blue, Smoky blue and Iceland green.

Please consult your Audi Centre for examples of Alcantara and carpet colours.

Audi exclusive colours



Chestnut brown



Jet grey



Alabaster white

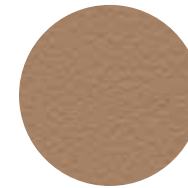

Sand beige

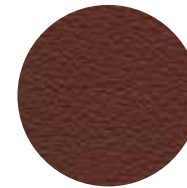

Saddle brown



Crimson red



Magnolia white



Havanna brown

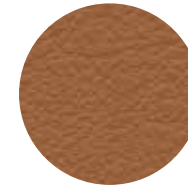

Cognac brown



Night blue

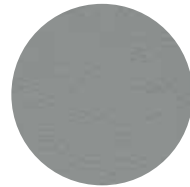

Cloudy grey

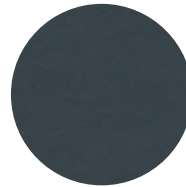

Smoky blue

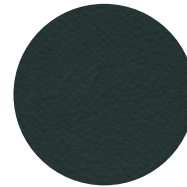

Iceland green

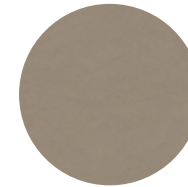

Powder beige

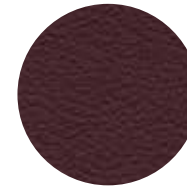

Classic red



Upholstery

Audi exclusive

Order Code		V8 Coupé	V10 Coupé	V10 plus	V8 Spyder	V10 Spyder	Basic RRP	Total RRP inc VAT
PYE S3G	Audi exclusive design package in black leather/Alcantara for R8 bucket seats. Includes leather-covered seat-side sections, headrests, radio surround and centre console. Seat-centre sections, control elements and knee bolster in Alcantara. Only available in combination with R8 bucket seats (P55)+ and R8 3-spoke contoured flat-bottomed multi-function Sports steering wheel in perforated leather (2PK or 2PF)	•	•	•	•	•	£1,787.50	£2,145.00
PYA S3G	Audi exclusive leather package 1 in Fine Nappa leather. Includes leather-covered seat upholstery, headrests, door trim inserts and door handle on passenger side. Backrest covers, seat-side trims and seat add-on parts come in the interior trim colour*	•	•	•	•	–	£2,500.00	£2,700.00
PYD S3G	Audi exclusive leather package 2 in Fine Nappa leather. Includes all the contents of Audi exclusive leather package 1 (PYA) plus: radio surround, centre console, door shoulder and side panel, dashboard, monoposto, instrument cowl, backrest covers, knee bolster and function pad in Fine Nappa leather. Also includes colour-coordinated seat side trims and seat add-on parts*	•	–	•	•	–	£5,000.00	£6,000.00
PYS S3G	Audi exclusive leather package 2 in Fine Nappa leather in stitched diamond design. Includes all the contents of Audi exclusive leather package 1 (PYA) plus: radio surround, centre console, door shoulder and side panel, dashboard, monoposto, instrument cowl, backrest covers, knee bolster and function pad. Seat centre section in stitched diamond design. Also includes colour-coordinated seat-side trims and seat add-on parts.* Only available in combination with Sports seats (WLF/PIE) on R8 V10 plus	•	–	•	•	–	£5,833.33	£7,000.00
PYT S3G	Audi exclusive leather package 2 in Fine Nappa leather in stitched diamond design for R8 bucket seats. Includes all the contents of Audi exclusive leather package 1 (PYA) plus: radio surround, centre console, door shoulder and side panel, dashboard, monoposto, instrument cowl, backrest covers, knee bolster and function pad. Seat centre section in stitched diamond design. Also includes colour-coordinated seat-side trims and seat add-on parts.* Only available in combination with R8 bucket seats (P55)	•	–	•	•	–	£5,833.33	£7,000.00
YSZ S3G	Audi exclusive backrest covers in body colour. Only available in combination with R8 bucket seats (P55)	•	•	•	•	•	£1,375.00	£1,650.00

Options are subject to availability and may extend delivery.

– = Not available
• = Available
S = Standard

*Leather and stitching (where applicable) can be specified in a variety of colours from the Audi exclusive range.

*It is recommended to order the interior colour Black with this option.

Please consult your Audi Centre for further information.

RRP – Recommended Retail Price.

VAT is calculated at 20% but this may alter to reflect any change in the applicable VAT rate.



Audi exclusive leather package 1



Audi exclusive leather package 2

Upholstery

Audi exclusive cabin options

Order Code		V8 Coupé	V10 Coupé	V10 plus	V8 Spyder	V10 Spyder	Basic RRP	Total RRP inc VAT
YSU S3G	Audi exclusive Fine Nappa leather-covered door sill trims.** Includes carpet cover strip and lower part of the A-pillar. Only available in combination with an Extended Fine Nappa leather package (PL3 or PL8) or an Audi exclusive leather package 2 in Fine Nappa leather (PYD, PYS or PYT)	•	•	•	•	•	£379.17	£455.00
YQN S3G	Audi exclusive seat-side trims in Fine Nappa leather.* Only available in combination with Audi exclusive leather package 2 in Fine Nappa leather (PYD). Only available in combination with Sports seats (WLF/PIE) on R8 V10 plus	•	•	•	•	•	£320.83	£385.00
YQO S3G	Audi exclusive centre console, ashtray cover and radio surround in Fine Nappa leather.* Only available in combination with an Extended Fine Nappa leather package (PL3 or PL8)	•	•	•	•	•	£1,108.33	£1,330.00
YXM S3G	Audi exclusive centre console in Carbon sigma. Includes handbrake grip in Carbon sigma. Not available in combination with Mobile telephone preparation – Low (PT2). Please note that this option removes the cigarette lighter and ashtray from the centre console	•	•	•	•	•	£833.33	£1,000.00
YQW S3G	Audi exclusive monoposto design package in Fine Nappa leather.* Includes leather-covered monoposto, knee bolster, instrument cowl and door handle on driver side	•	•	•	•	–	£1,020.83	£1,225.00
YQL S3G	Audi exclusive air vent sleeves in Fine Nappa leather.* Includes leather-covered air vent louvres, adjustment handles, switch panel trims and the frames of the side air vents**	•	•	•	•	•	£566.67	£680.00
YSK S3G	Audi exclusive headlining in Alcantara*	•	•	•	–	–	£1,437.50	£1,725.00
YSE S3G	Audi exclusive headlining in Alcantara in stitched diamond design.* Only available in combination with Alcantara headlining in stitched diamond design (6NT) and Extended Fine Nappa leather package in stitched diamond design (PL8) or Audi exclusive leather package 2 in Fine Nappa leather with stitched diamond design (PYS or PYT)	•	•	•	–	–	£2,270.83	£2,725.00
YSL S3G	Audi exclusive headlining and rear shelf trim in Alcantara*	•	•	•	–	–	£2,475.00	£2,970.00

Options are subject to availability and may extend delivery.

– = Not available
 • = Available
 S = Standard

*The leather, headlining, stitching and piping (where applicable) can be selected from any of the Audi exclusive colours shown on page 48. The carpet colour can also be selected from any of the exclusive colours shown on page 48.

**It is recommended to order an Extended Fine Nappa leather package (PL3 or PL8) or Audi exclusive leather package 2 in Fine Nappa leather (PYD) with this option.

RRP – Recommended Retail Price.

VAT is calculated at 20% but this may alter to reflect any change in the applicable VAT rate.



Upholstery

Audi exclusive

Order Code		V8 Coupé	V10 Coupé	V10 plus	V8 Spyder	V10 Spyder	Basic RRP	Total RRP inc VAT
YSH S3G	Audi exclusive rear panel in Alcantara*	-	-	-	●	●	£791.67	£950.00
YST S3G	Audi exclusive headlining and rear shelf trim in Fine Nappa leather*	●	●	●	-	-	£2,608.33	£3,130.00
YQJ S3G	Audi exclusive windscreen frame in Alcantara.* Includes interior trim of windscreen and sun visors in Alcantara	-	-	-	●	●	£1,500.00	£1,800.00
YQK S3G	Audi exclusive windscreen frame in Fine Nappa leather.* Includes interior trim of windscreen and sun visors in Fine Nappa leather	-	-	-	●	●	£1,500.00	£1,800.00



Options are subject to availability and may extend delivery.

- = Not available
● = Available
S = Standard

*The leather, headlining, stitching and piping (where applicable) can be selected from any of the Audi exclusive colours shown on page 48. The carpet colour can also be selected from any of the exclusive colours shown on page 48.

RRP - Recommended Retail Price.

VAT is calculated at 20% but this may alter to reflect any change in the applicable VAT rate.

Upholstery

Audi exclusive control elements

Order Code		V8 Coupé	V10 Coupé	V10 plus	V8 Spyder	V10 Spyder	Basic RRP	Total RRP inc VAT
YRH S3G	Audi exclusive leather-covered steering wheel rim*	•	•	•	•	•	£333.33	£400.00
YRB S3G	Audi exclusive leather controls package.* Includes leather-covered steering wheel, handbrake grip and gearshift gaiter. Only available in combination with leather gear knob (6Q2). Not available in combination with Audi exclusive suede controls package (YUC)	•	•	•	•	•	£545.83	£655.00
YUC S3G	Audi exclusive suede controls package.* Includes suede-covered steering wheel, handbrake grip and gearshift gaiter. Please note that due to the nature of suede, in time signs of wear may appear. Only available in combination with leather gear knob (6Q2). Not available in combination with Audi exclusive leather controls package (YRB)	•	•	•	•	•	£545.83	£655.00

Audi exclusive carpets and floor mats

YSR S3G	Audi exclusive floor mats with leather piping.* Not available in combination with Audi exclusive carpets and rear shelf (YSQ)	•	•	•	•	•	£254.17	£305.00
YTZ S3G	Audi exclusive floor mats in black with R8 logo	•	•	•	•	•	£379.17	£455.00
YSQ S3G	Audi exclusive carpets and rear shelf including floor mats with leather piping.* Not available in combination with Audi exclusive floor mats (YSR)	•	•	•	•	•	£1,108.33	£1,330.00
YQM S3G	Audi exclusive luggage compartment lining in Alcantara*	•	•	•	•	•	£1,370.83	£1,645.00

*The leather, headlining, stitching and piping (where applicable) can be selected from any of the Audi exclusive colours. The carpet colour can also be selected from any of the exclusive colours.

Options are subject to availability and may extend delivery.

- = Not available
• = Available
S = Standard

RRP – Recommended Retail Price.

VAT is calculated at 20% but this may alter to reflect any change in the applicable VAT rate.





Inlays

Attention to detail can make a big impact. From a contemporary black Piano finish to a Carbon sigma, our selection of inlays offer the perfect finishing touch to your car's interior.





Inlays

Inlays are the all-important finishing touch that add flair and interest to your car's interior and are available in a variety of textures and finishes.

Order Code		V8 Coupé	V10 Coupé	V10 plus	V8 Spyder	V10 Spyder	Basic RRP	Total RRP inc VAT
—	Matt silk finish, black	S	S	—	S	S	No charge	No charge
5MN	Inlays in Carbon sigma. Includes Carbon sigma inlays on monoposto, centre console, door trim and door handle on passenger side. Please note that in combination with an Extended Fine Nappa leather package (PL3 or PL8), the Carbon sigma inlays replace the leather on the monoposto and door handle on passenger side	●	●	S	●	●	£1,666.67	£2,000.00
STL	Inlays in Piano finish, black. Includes Piano black inlays on centre console, door trim and radio surround	●	●	—	●	●	£1,125.00	£1,350.00
YTF S3G	Audi exclusive inlays in body colour. Includes body-coloured inlays on centre console, door trim and radio surround	●	●	●	●	●	£2,041.67	£2,450.00
YQP S3G	Audi exclusive inlays in Fine Nappa leather.* Includes Fine Nappa leather inlays on centre console, door trim, and door handle on passenger side. Only available in combination with an Extended Fine Nappa leather package (PL3 or PL8) or Audi exclusive leather package 2 in Fine Nappa leather (PYD)	●	●	—	●	●	£508.33	£610.00

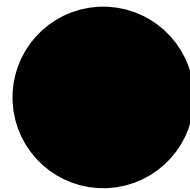

Matt silk finish, black



Carbon sigma - 5MN

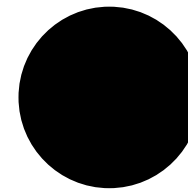

Piano finish, black - STL



Audi exclusive inlays in body colour - YTF/S3G

Options are subject to availability and may extend delivery.

— = Not available
 ● = Available
 S = Standard

*The leather, headlining, stitching and piping (where applicable) can be selected from any of the Audi exclusive colours. The carpet colour can also be selected from any of the exclusive colours.

Please see page 57 for inlay locations.

RRP - Recommended Retail Price.

VAT is calculated at 20% but this may alter to reflect any change in the applicable VAT rate.

Leather packages and inlays

Fine Nappa leather upholstery

- 1 Seats
- 2 Door handle on passenger side matching seat colour
- 3 Door-trim insert matching seat colour

Extended Fine Nappa leather package (PL3 or PL8)

- 4 Black dashboard
- 5,6 Black top shoulder and side-panel trim
- 7 Black storage compartment in door
- 8 Black monoposto
- 9 Black instrument cowl
- 10 Black cover for storage compartment
- 11 Black knee bolster
- 12 Black function pad

Inlays

- 13 Monoposto (Carbon sigma only)
- 14 Inlays in centre console
- 15 Inlays in door trim
- 16 Door handle on passenger side (Carbon sigma and Fine Nappa leather only)

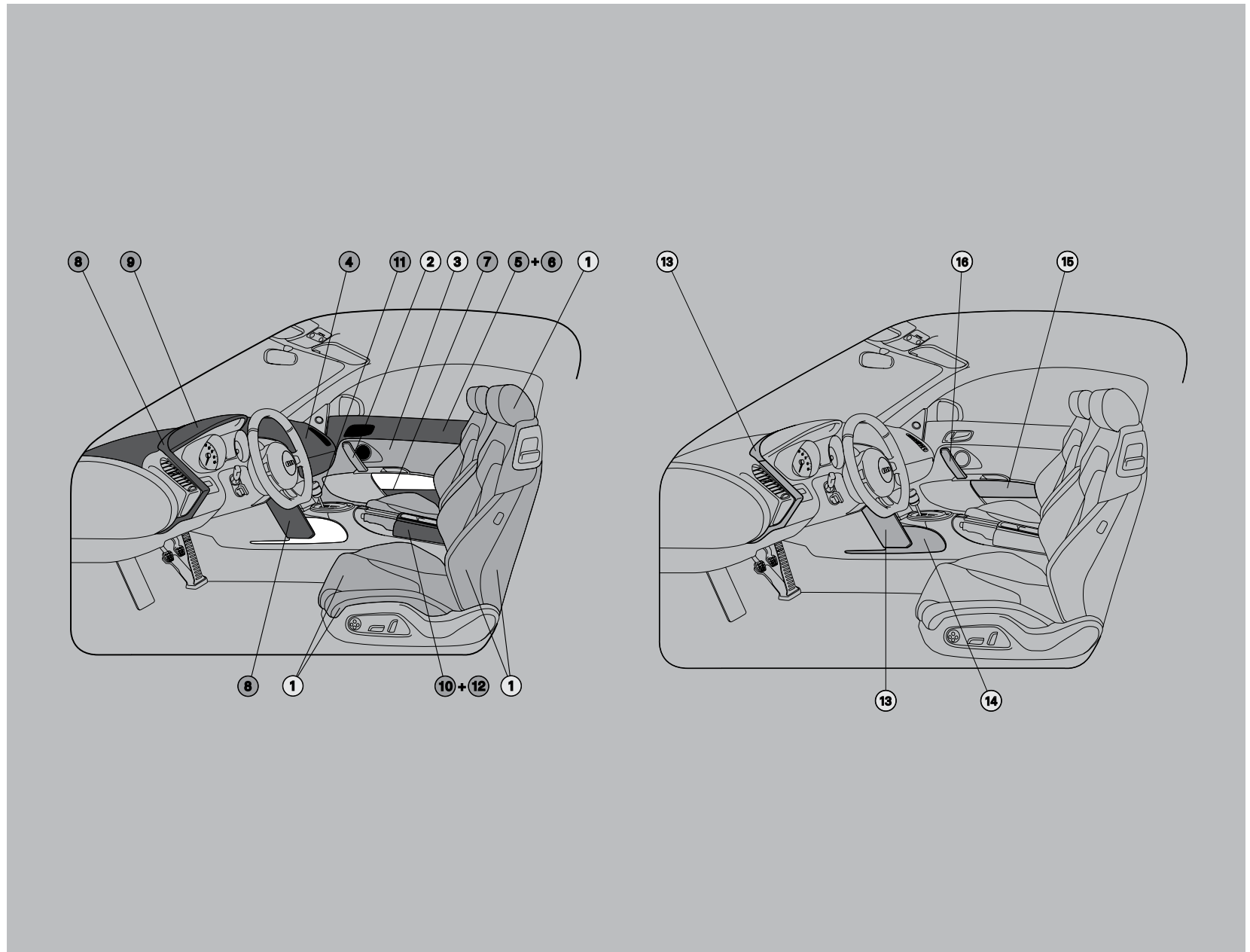

Options

Every driver has different needs, which is why we have created some useful options to further enhance your car. For extra comfort, support, style or function, you can choose from a variety of additional features, tailoring everything from your audio equipment to your wheels and lighting.





Wheels, brakes and suspension

Choose a set of specially selected alloy wheels to subtly enhance the way your car looks and drives.



19" '5-arm double-spoke' design
alloy wheels - PQ2



19" '5-arm double-spoke' design
alloy wheels in high-gloss finish - PQF



19" '5-arm double-spoke' design
alloy wheels in titanium finish - PQI



19" '10-spoke Y' design
alloy wheels in high-gloss finish - PQ1



19" '5-arm double-spoke Y' design
alloy wheels in titanium finish - PQR



19" '5-arm double-spoke Y' design
alloy wheels in black gloss finish - PQM

Wheels, brakes and suspension

Order Code		V8 Coupé	V10 Coupé	V10 plus	V8 Spyder	V10 Spyder	Basic RRP	Total RRP inc VAT
PQ2	19" '5-arm double-spoke' design alloy wheels (19" x 8.5J) 235/35 front tyres and 19" x 11J 295/30 R19 rear tyres)	S	●	●	S	●	No charge	No charge
PQF	19" '5-arm double-spoke' design alloy wheels in high-gloss finish (19" x 8.5J) 235/35 front tyres and 19" x 11J 305/30 R19 rear tyres)	●	●	●	●	●	£475.00	£570.00
PQI	19" '5-arm double-spoke' design alloy wheels in titanium finish (19" x 8.5J) 235/35 front tyres and 19" x 11J 305/30 R19 rear tyres)	●	●	●	●	●	£475.00	£570.00
PQ1	19" '10-spoke Y' design alloy wheels in high-gloss finish (19" x 8.5J) 235/35 front tyres and 19" x 11J 305/30 R19 rear tyres)	-	●	-	-	●	£725.00	£870.00
PQR	19" '5-arm double-spoke Y' design alloy wheels in titanium finish (19" x 8.5J) 235/35 front tyres and 19" x 11J 305/30 R19 rear tyres)	-	-	●	-	-	£475.00	£570.00
PQM	19" '5-arm double-spoke Y' design alloy wheels in black high-gloss finish (19" x 8.5J) 235/35 front tyres and 19" x 11J 305/30 R19 rear tyres)	-	-	●	-	-	£475.00	£570.00
1BL	Audi magnetic ride. Adaptive suspension system with two selectable modes (Normal or Sport). Sensors in the car monitor the road conditions and adjust the damping effect by varying a magnetic charge which passes through a fluid-based shock absorber, delivering improved road handling, outstanding chassis control and excellent driving comfort	●	S	-	●	S	£979.17	£1,175.00
PCS	Ceramic brakes. 19-inch high-performance braking system with carbon-fibre reinforced ceramic brake discs, with 6-piston fixed brake callipers in the front and 4-piston fixed brake callipers in the rear. Includes specially designed cooling ducts in the ventilated and perforated brake discs, brake callipers in high-gloss anthracite, and 'Audi ceramic' inscription on front and rear callipers	●	●	S	●	●	£6,079.17	£7,295.00

Options are subject to availability and may extend delivery.

- = Not available
● = Available
S = Standard

RRP – Recommended Retail Price.

VAT is calculated at 20% but this may alter to reflect any change in the applicable VAT rate.

Audio and communication

Stay in touch using our range of communication functions, and give each journey its own soundtrack with our advanced audio equipment.

Order Code		V8 Coupé	V10 Coupé	V10 plus	V8 Spyder	V10 Spyder	Basic RRP	Total RRP inc VAT
9VK	Bang & Olufsen sound system. Designed specifically for the Audi R8, providing surround sound reproduction with dynamic compensation for road noise, digital amplifier and 12 high-performance loudspeakers. Total output of 465 watts	●	S	●	●	S	£791.67	£950.00
PT2	Mobile telephone preparation – Low with Bluetooth interface, integrated seat-belt microphones and voice control. Provides hands-free connection via Bluetooth using mobile-phone aerial. Alternatively it can use a cradle, located in storage compartment on centre console, with charging facility for optimal reception via external aerial. Cradle available at extra cost – please contact your Audi Centre for phone compatibility. Not available in combination with Audi exclusive centre console in Carbon sigma (YXM)	●	●	●	●	●	£145.83	£175.00
7A2 UFO	CD changer. For six CDs, integrated into rear shelf between seats. Please note that this option replaces Audi Music Interface (AMI)	●	●	●	●	●	£125.00	£150.00

Options are subject to availability and may extend delivery.

- = Not available
- = Available
- S = Standard

RRP – Recommended Retail Price.

VAT is calculated at 20% but this may alter to reflect any change in the applicable VAT rate.



Bang & Olufsen sound system



CD changer



Mobile telephone preparation – Low



Interior equipment

Specify every detail of your car's interior with this range of options.

Options are subject to availability and may extend delivery.

-- = Not available
 ● = Available
 S = Standard

*HomeLink® is a registered trademark of Johnson Controls. For information on compatibility, visit www.homelink.com.

RRP – Recommended Retail Price.

VAT is calculated at 20% but this may alter to reflect any change in the applicable VAT rate.

Order Code		V8 Coupé	V10 Coupé	V10 plus	V8 Spyder	V10 Spyder	Basic RRP	Total RRP inc VAT
6NN	Alcantara headlining. Available in Black or Luxor beige, depending on interior colour choice. Only available in Black on the R8 V10 plus	●	●	●	–	–	£958.33	£1,150.00
6NT	Alcantara headlining in stitched diamond design. Available in Black with stitching in Lunar silver. Stitching and headlining only available in Black on the R8 V10 plus. Only available in combination with Extended Fine Nappa leather package in stitched diamond design (PL8) or Audi exclusive leather package 2 in stitched diamond design (PYS or PYT)	●	●	●	–	–	£1,625.00	£1,950.00
7M7	Carbon sigma door sill trims with aluminium inserts and R8 badge	●	●	●	●	●	£766.67	£920.00
7M9	Illuminated door sill trims with aluminium insert and R8 badge	●	●	●	●	●	£416.67	£500.00
YVY S3G	Audi exclusive Carbon sigma door sill trims with illuminated aluminium inserts and R8 badge. Only available in combination with illuminated door sill trims (7M9)	●	●	●	●	●	£1,183.33	£1,420.00
YVM S3G	Audi exclusive personalised door sill trims with illuminated aluminium inserts. Includes personalisation of badge on door sill trims with design of your choice. Please note that designs are subject to factory approval. Only available in combination with illuminated door sill trims (7M9)	●	●	●	●	●	£1,637.50	£1,965.00
YVZ S3G	Audi exclusive personalised Carbon sigma door sill trims with illuminated aluminium inserts. Includes personalisation of badge on door sill trims with design of your choice. Please note that designs are subject to factory approval. Only available in combination with illuminated door sill trims (7M9)	●	●	●	●	●	£2,054.17	£2,465.00
		●	–	–	–	–	£2,775.00	£3,330.00
NM5	Audi exclusive Carbon sigma engine bay trim. Includes light package (PAM) on R8 V8 Coupé	–	●	S	–	–	£2,333.33	£2,800.00
		–	–	–	●	●	£1,125.00	£1,350.00
VC1	Garage door opener (Homelink®*). Programmable radio-operated remote control for up to three compatible doors/gates. Control buttons integrated in front roof module	●	●	●	●	●	£170.83	£205.00



Audi exclusive Carbon sigma engine bay trim



Audi exclusive Carbon sigma door sill trims with illuminated aluminium inserts

Interior equipment

Order Code		V8 Coupé	V10 Coupé	V10 plus	V8 Spyder	V10 Spyder	Basic RRP	Total RRP inc VAT
6Q2	Leather gear knob	●	●	●	●	●	No charge	No charge
6XK 4L6	Light and rain sensor package. Includes auto-dimming rear-view mirror, light and rain sensors and electrically adjustable, heated, folding and auto-dimming door mirrors In combination with Light package	●	S	–	●	S	£437.50	£525.00
		●	–	–	●	–	£254.17	£305.00
PAM	Light package. Includes auto-dimming rear-view mirror, light and rain sensors and LED lights illuminating the footwell (and engine compartment on R8 Coupé)	●	S	S	–	–	£441.67	£530.00
		–	–	–	●	S	£258.33	£310.00
GS3	Stainless steel pedals with black rubber inserts	●	S	S	●	S	£229.17	£275.00
QE1	Storage package. Comprising storage nets on front-seat backrests, storage compartment under the front seats and luggage net. Not available in combination with R8 bucket seats (P55). Only available in combination with Sports seats (WLF/PIE) on R8 V10 plus	●	●	●	–	–	£183.33	£220.00
		–	–	–	●	●	£145.83	£175.00

Options are subject to availability and may extend delivery.

- = Not available
- = Available
- S = Standard

RRP – Recommended Retail Price.

VAT is calculated at 20% but this may alter to reflect any change in the applicable VAT rate.



Luggage sets

R8 luggage sets are available in finest-grade leather in the specified seat colour, and feature the R8 logo. The carbon handles, Nardja lining and various contrasting seams make these case sets true collectables.

Options are subject to availability and may extend delivery.

- = Not available
- = Available
- S = Standard

*Available in 15 different Audi exclusive colours to match or contrast with chosen seat colour.

RRP – Recommended Retail Price.

VAT is calculated at 20% but this may alter to reflect any change in the applicable VAT rate.

Order Code		V8 Coupé	V10 Coupé	V10 plus	V8 Spyder	V10 Spyder	Basic RRP	Total RRP inc VAT
YQQ S3G	Two-piece R8 luggage set. Handmade in Germany and tailored to fit behind the seats of the R8 Coupé. Consists of two suitcases in black leather with contrast stitching and interior Nardja lining in grey, leather handles with real Carbon inlay and R8 embossing	•	•	•	-	-	£1,658.33	£1,990.00
YQR S3G	Audi exclusive two-piece R8 luggage set. As above, in a choice of Audi exclusive leather with contrast stitching*	•	•	•	-	-	£2,083.33	£2,500.00
YQT S3G	Five-piece R8 luggage set. Handmade in Germany and tailored to fit in the R8 luggage compartment. Consists of one suitcase, one briefcase, one suit carrier and two toiletry bags in black leather with contrast stitching and interior Nardja lining in grey, leather handles with real Carbon inlay and R8 embossing	•	•	•	•	•	£3,191.67	£3,830.00
YQU S3G	Audi exclusive five-piece R8 luggage set. As above, in a choice of Audi exclusive leather with contrast stitching*	•	•	•	•	•	£4,000.00	£4,800.00



Two-piece R8 luggage set



Five-piece R8 luggage set, in Audi exclusive leather with contrast stitching



Five-piece R8 luggage set

Exterior equipment

Make sure your car looks exactly as you want it to by selecting some of our striking options.

Order Code		V8 Coupé	V10 Coupé	V10 plus	V8 Spyder	V10 Spyder	Basic RRP	Total RRP inc VAT
8N7	High-beam assist. Automatically adjusts headlights from high beam to dipped beam when another vehicle is approaching or when other ambient lighting is detected (e.g. street lights) by a camera on interior mirror. Only available in combination with light and rain sensor package (6XK/4L6) or light package (PAM)	●	●	●	●	●	£100.00	£120.00
6FQ	Carbon sigma door mirror housings. Only available in combination with door mirrors – electrically adjustable and heated (6XD). Not available in combination with light and rain sensor package (6XK/4L6)	●	●	S	●	●	£1,000.00	£1,200.00
PQE	Black styling package – Coupé. Radiator-grille frame, radiator grille, licence plate surround and exhaust tailpipes in high-gloss black. Rear window air outlets in matt black on R8 V10 Coupé	●	●	–	–	–	£400.00	£480.00
PQO	Black styling package – Spyder. Radiator-grille frame, radiator grille, licence plate surround, exhaust tailpipes and rear air outlets in high-gloss black	–	–	–	●	●	£400.00	£480.00

Options are subject to availability and may extend delivery.

- = Not available
- = Available
- S = Standard

RRP – Recommended Retail Price.

VAT is calculated at 20% but this may alter to reflect any change in the applicable VAT rate.



Safety and security

Intelligent technology designed to give you better all-round awareness and safety on the road.

Options are subject to availability and may extend delivery.

- = Not available
- = Available
- S = Standard

RRP – Recommended Retail Price.

VAT is calculated at 20% but this may alter to reflect any change in the applicable VAT rate.

Order Code		V8 Coupé	V10 Coupé	V10 plus	V8 Spyder	V10 Spyder	Basic RRP	Total RRP inc VAT
7X4	Audi parking system plus. Aids parking by acoustically and visually indicating distances to obstacles at front and rear. Visual display of symbols on screen indicates distances to obstacles. Measured by sensors integrated into front and rear bumpers	•	•	•	•	•	£558.33	£670.00
7X8	Audi parking system advanced with reversing camera. Aids parking by acoustically and visually indicating distances to obstacles. Image of area behind vehicle is displayed on screen with guiding lines. Measured by sensors integrated into front and rear bumpers and reversing camera	•	•	•	•	•	£891.67	£1,070.00
7K7	Tyre-pressure monitoring system. Monitors tyres based on air pressures specified by the driver and programmed into the Driver's Information System (DIS)	•	S	S	•	S	£229.17	£275.00
8T2	Cruise control. Maintains any speed above 18mph, provided that the engine power output and engine braking effect permit it. Operated via separate steering column stalk, set speed is displayed in the Driver's Information System (DIS). Also available as part of the Comfort package	•	•	•	•	•	£187.50	£225.00
—	CobraTrak 5. Thatcham Category 5-approved tracking device that provides the highest level of vehicle security. CobraTrak 5 uses GPS and GSM technology to provide seamless tracking and recovery across 36 European countries. Also includes Automatic Driver Recognition cards and remote engine immobilisation. Please note that this option is a Centre-fitted accessory and needs to be ordered and fitted by your Audi Centre (ZGB420054999A). Price shown includes one year's subscription to the CobraTrak service but excludes fitting	•	•	•	•	•	£723.40	£850.00



Audi parking system advanced with reversing camera



R8 3-spoke contoured flat-bottomed multi-function Sports steering wheel with paddles and cruise control

Steering wheels

Order Code		V8 Coupé	V10 Coupé	V10 plus	V8 Spyder	V10 Spyder	Basic RRP	Total RRP inc VAT
2PF	R8 3-spoke contoured flat-bottomed multi-function Sports steering wheel in perforated leather. More heavily contoured and ergonomic steering-wheel rim in perforated leather with R8 badge	●	●	S	●	●	£295.83	£355.00
2PK	R8 3-spoke contoured flat-bottomed multi-function Sports steering wheel in perforated leather with paddles. More heavily contoured and ergonomic steering-wheel rim in perforated leather with R8 badge, and aluminium-look gear-shift paddles behind steering wheel	●	●	S	●	●	£295.83	£355.00

Options are subject to availability and may extend delivery.

- = Not available
- = Available
- S = Standard

RRP – Recommended Retail Price.

VAT is calculated at 20% but this may alter to reflect any change in the applicable VAT rate.



Factory Collection from Neckarsulm

An exclusive event

When you choose an Audi R8, you become the owner of a very special car. To reflect this, we offer you the opportunity to visit the equally stunning birthplace of this model. At Neckarsulm you can witness for yourself the pride and dedication that goes into every single R8 we produce.

Options are subject to availability and may extend delivery.

- = Not available
 • = Available
 S = Standard

RRP - Recommended Retail Price.

VAT is calculated at 20% but this may alter to reflect any change in the applicable VAT rate.

Planning your day in Neckarsulm

When you choose Factory Collection, we will provide you with your own Factory Collection book. It contains all the information you'll need, including ideas and inspiration for planning your visit, your journey to the factory and your route home in your brand new Audi R8.

Order Code	V8 Coupé	V10 Coupé	V10 plus	V8 Spyder	V10 Spyder	Basic RRP	Total RRP inc VAT
A22	•	•	•	•	•	£416.67	£500.00

Factory Collection from Neckarsulm includes:

- ▶ Chauffeur transfer from airport or hotel to factory
- ▶ Factory and museum tour (Monday to Friday)
- ▶ Lunch and refreshments
- ▶ R8 handover
- ▶ Full pre-delivery inspection
- ▶ Temporary fully comprehensive insurance and international registration
- ▶ European breakdown assistance
- ▶ R8 Factory Collection book (detailing suggested routes, recommendations on hotels, flights, airports and driving regulations)
- ▶ Post-collection check and registration in the UK at your local Audi Centre (within 14 days)

Contact your Audi Centre for full details



R8 Driving Experience

The Audi R8 is a car that combines breathtaking performance, beautiful design and renowned Audi technology. As part of your purchase, you will be invited to participate in an exclusive Audi R8 Driving Experience so that you can explore its full potential.

The circuit

Silverstone is the home of the British Grand Prix and the ideal setting for the Audi R8 Driving Experience. The course takes place at the infield driver training area and out on the Stowe Circuit, which features a great mixture of long straights, fast corners and technically demanding chicanes. So it's the perfect place to explore the performance and handling of the R8, as you attempt things that simply wouldn't be possible on the open road.

The Experience

This is your opportunity to hone your driving skills at Silverstone, where you'll have a chance to sample the unbridled power of the R8 V10. This performance car features a 5.2 FSI engine, quattro all-wheel-drive and a lightweight Aluminium Space Frame, enabling it to sprint from 0 to 62mph in a mere 3.6 seconds. The result is an unforgettable driving experience.

Our expert instructors will coach you in car control and controlled driving at speed, showing you how to evaluate risks and recognise dangers. You'll get to try a whole range of techniques, including effective cornering, controlled understeer, high-speed lane changes, braking at speed and avoidance manoeuvres – it's a chance to push your driving abilities to the limit. Finally, you'll go for 'hot laps' with an instructor, who'll show you exactly what the R8 is capable of in the hands of a professional.

Visit audi.co.uk/R8drivingexperience for terms and conditions.



Looking after your Audi

When you've chosen your ideal model, it's reassuring to know that it will remain in safe hands. That's why we've created products to protect your Audi: from extended warranties to Audi Complete – our comprehensive service and maintenance package. And there's also a range of Audi accessories and merchandise to choose from, enabling you to further enhance and safeguard your car.





Audi Complete

Audi Complete is simply a way to look after the servicing and maintenance costs for your Audi in a single package. You pay a one-off or monthly fee and we'll cover all your servicing, maintenance and tyres for the next three years, including your first MOT. It means you only have to pay for fuel, insurance and your Road Fund Licence. So you can be reassured that your car will be maintained by trained Audi Technicians, using genuine Audi parts. You can also opt for our Service only or Service and Maintenance packages if you prefer.

*Retail customers only. Pricing based on 3 years/30,000 miles (whichever occurs sooner). All pricing is a 'starting from' price for the Audi R8 model range and is therefore subject to change and mileage/model-dependent.

Warranty

Options are subject to availability and may extend delivery.

- = Not available
• = Available
S = Standard

**Only available prior to registration of your R8. Please speak to a member of staff at your Audi Centre for full details.

RRP – Recommended Retail Price.

VAT is calculated at 20% but this may alter to reflect any change in the applicable VAT rate.

Order Code		R8 V8	R8 V10	R8 V10 plus	Basic RRP	Total RRP inc VAT
-	Audi Complete – Service only. Comprehensive care for your Audi covering all your servicing for 3 years. Visit your local Audi Centre for further information or audi.co.uk/audicomplete for full details including terms and conditions	•	-	-	£50.00	£60.00*
		-	•	•	£50.00	£60.00*
-	Audi Complete – Service and Maintenance. Comprehensive care for your Audi covering all your servicing and maintenance for 3 years, as well as your first MOT. Visit your local Audi Centre for further information or audi.co.uk/audicomplete for full details including terms and conditions	•	-	-	£100.00	£120.00*
		-	•	•	£89.17	£107.00*
-	Audi Complete – Service, Maintenance and Tyres. Comprehensive care for your Audi covering all your servicing, maintenance and tyres for 3 years, as well as your first MOT. Visit your local Audi Centre for further information or audi.co.uk/audicomplete for full details including terms and conditions	•	-	-	£229.17	£275.00*
		-	•	•	£218.33	£262.00*

Order Code		R8 V8	R8 V10	R8 V10 plus	Basic RRP	Total RRP inc VAT
-	Audi Warranty. Covers you for unlimited mileage in the first two years of ownership, and up to 60,000 miles in the third year. Transferable between owners**	S	S	S	No charge	No charge
EA6	Audi Warranty. Covers you for up to 4 years or 75,000 miles, whichever occurs sooner. Cover includes a two-year unlimited mileage warranty, and up to 75,000 miles in the third and fourth years. Transferable between owners**	•	•	•	£862.50	£1,035.00
EA9	Audi Warranty. Covers you for up to 5 years or 90,000 miles, whichever occurs sooner. Cover includes a two-year unlimited mileage warranty, and up to 90,000 miles in the third and fourth years. Transferable between owners**	•	•	•	£2,129.17	£2,555.00

Merchandise

From the enthusiasts' motorsport collection to the sophisticated Audi collection, there's a wide variety of adults' and children's clothing, lifestyle accessories and collectables, all of which bear the Audi name.

Please speak to a member of our team at your local Audi Centre to see the full Audi collection and to place an order. A selection of Audi merchandise is also available to buy at audi.co.uk/merchandise.



Audi Difference

The experts in Vorsprung durch Technik

Our Audi Approved Master Technicians have undergone an impressive 100,000 hours of training over a 10-year programme to ensure they have the latest technical expertise for maintaining and servicing your Audi. All our Service Advisors undergo a specialist induction and training to ensure they are Audi professionals and able to talk to you about any issues you may have with your Audi vehicle.

Servicing tailored to your needs

Regular servicing is key to safeguarding your Audi's performance and a full Audi service history could help you enhance the future re-sale value. To make servicing easy, the Audi Service Schedules have been designed to work with your individual driving style and vehicle.

We offer two different schedules: the fixed Inspection Service and the variable LongLife Service schedule. The conventional fixed Inspection Service schedule has fixed intervals for the Oil-change Service and Inspection Service, which are determined by time and distance.

With the variable LongLife Service schedule, the Inspection Service intervals are also fixed but the Oil-change Service intervals are variable. Sensors take account of driving style and conditions to determine when the Oil-change Service is required and the driver is informed via the on-board service interval display.

The choice of Service Schedule will depend on journey type and mileage as well as individual driving style and conditions. The table to the right can be used for guidance but your Audi Centre will help you to determine the most suitable Service schedule for you based on your individual circumstances and preferences.

Fixed Inspection Service Schedule

	Vehicle usage:
Mileage	Less than 10,000 miles per annum Mainly city/town centre driving. Short journeys.
	Service Intervals:
Oil-change Service	Fixed to every 9,000+ miles/1 year
Inspection Service	Fixed to every 19,000+ miles/2 years

Variable LongLife Service Schedule

	Vehicle usage:
Mileage	More than 10,000 miles per annum Motorway and main road driving. Mainly longer distance journeys. Constant speeds.
	Service Intervals:
Oil-change Service	Variable to a maximum of every 19,000+ miles/2 years
Inspection Service	Fixed to every 19,000+ miles/2 years

When a vehicle is frequently used in the following conditions, we recommend a Fixed Inspection Service Schedule, regardless of mileage:

Uneconomical driving styles, e.g. heavy acceleration and braking, constant use of high revs

High engine-loading conditions, e.g. frequent towing and hill climbs

*As indicated by the service interval display. Mileages are approximate as the Service Indicator system uses kilometres as its distance measurement.

Your convenience comes first

At Audi you can choose from a range of convenient services that suit your needs. Why not book a 'service while you wait' appointment* and enjoy our complimentary refreshments while your car is with us? Or, if you need to be mobile, take advantage of one of our courtesy cars which we can even deliver to you.* We guarantee we can service your Audi within 5 days without a courtesy car or within 10 days if you need transport. We will also ensure your car is returned to you with a full valet.

Audi Genuine Parts

You can rest assured that only Audi Genuine Parts will be used on your vehicle. What's more, Audi parts and labour come with a 2-year guarantee.**

No hidden costs

We believe strongly in transparency when it comes to our prices. For added peace of mind, we will give you a quotation over the phone for the work you have requested and email you the price confirmation. We'll consult you if any additional work on your car is needed when it is with us. We won't carry out any extra work without asking your permission first.

All part of the service

Whenever we see an Audi for a service, we connect it directly to our headquarters in Ingolstadt which enables us to check your car's software and make sure it's as up-to-date as possible. If the factory has released a software upgrade for your model, it can be applied immediately - improving anything from your car's efficiency to the precision of its parking system.

Audi Roadside Assistance

Your new car comes complete with 3 years' complimentary roadside assistance and recovery across the UK, provided by RAC Motoring Services. Also included is roadside assistance throughout Europe, managed by RAC Motoring Services.

For further information and terms and conditions please visit audi.co.uk.

* Subject to availability.

**Excludes wear and tear.



R8 Coupé

technical data

	Coupé					
Engine	4.2 FSI quattro	4.2 FSI quattro	5.2 FSI quattro	5.2 FSI quattro	5.2 FSI quattro V10 plus	5.2 FSI quattro V10 plus
Transmission	6-speed manual	7-speed S tronic	6-speed manual	7-speed S tronic	6-speed manual	7-speed S tronic
Cylinder	V8	V8	V10	V10	V10	V10
Displacement, cubic cm	4163	4163	5204	5204	5204	5204
Max. power ¹ , PS	430	430	525	525	550	550
Max. torque, Nm at rpm	430/4500 - 6000	430/4500 - 6000	530/6500	530/6500	540/6500	540/6500
Top speed ³ , mph	188	187	197	195	198	197
0-62mph acceleration, seconds	4.6	4.3	3.9	3.6	3.8	3.5
CO ₂ emissions ² , g/km	332	289	346	305	346	299
Benefit in kind (BIK)%	35%	35%	35%	35%	35%	35%
Fuel consumption ² , mpg (l/100km) Urban	13.3 (21.3)	14.6 (19.3)	12.7 (22.2)	13.8 (20.5)	12.7 (22.2)	14.2 (19.9)
Fuel consumption ² , mpg (l/100km) Extra Urban	28.2 (10.0)	33.6 (8.4)	26.6 (10.6)	31.7 (8.9)	26.6 (10.6)	32.8 (8.6)
Fuel consumption ² , mpg (l/100km) Combined	19.9 (14.2)	22.8 (12.4)	19.0 (14.9)	21.6 (13.1)	19.0 (14.9)	21.9 (12.9)
ABI insurance group, 1-50 ⁴	50 E	50 E	50 E	50 E	50 E	50 E
Unladen weight ⁴ , kg	1560	1585	1620	1645	1570	1595
Gross weight limit, kg	1860	1885	1920	1945	1870	1895
Luggage compartment capacity, rear seats upright, litres	100	100	100	100	100	100
Fuel tank capacity approx, litres	90	90	90	90	90	90
Emission standard	EUS	EUS	EUS	EUS	EUS	EUS

⁴Highest insurance group rating shown. Group may be lower dependent on trim level. Please visit www.thatcham.org/abigrouprating for details.

¹The given value was obtained in accordance with the specified measurement procedure (the respective current version of the Directive 80/1269/EEC).

²Fuel consumption and CO₂ emissions figures are obtained under standardised test conditions (Directive 93/116/EEC) using a representative model. This allows direct comparison between different models from different manufacturers, but may not represent the actual fuel consumption achieved in 'real world' driving conditions. More information is available at www.vca.gov.uk.

³Top speed is achieved in top gear.

⁴Vehicle's unladen weight without driver (calculated in accordance with the current version of Directive 80/1268/EEC). The fitting of additional equipment may increase the vehicle's unladen weight and drag coefficient, whereupon the potential carrying capacity and top speed will be correspondingly reduced.

R8 Spyder technical data

	Spyder			
Engine	4.2 FSI quattro	4.2 FSI quattro	5.2 FSI quattro	5.2 FSI quattro
Transmission	6-speed manual	7-speed S tronic	6-speed manual	7-speed S tronic
Cylinder	V8	V8	V10	V10
Displacement, cubic cm	4163	4163	5204	5204
Max. power ¹ , PS	430	430	525	525
Max. torque, Nm at rpm	430/4500 - 6000	430/4500 - 6000	530/6500	530/6500
Top speed ³ , mph	187	187	194	193
0-62mph acceleration, seconds	4.8	4.5	4.1	3.8
CO ₂ emissions ² , g/km	337	294	349	310
Benefit in kind (BIK)%	35%	35%	35%	35%
Fuel consumption ² , mpg (l/100km) Urban	13.3 (21.3)	14.1 (19.6)	12.7 (22.2)	13.8 (20.5)
Fuel consumption ² , mpg (l/100km) Extra Urban	27.4 (10.3)	32.8 (8.6)	26.4 (10.7)	30.7 (9.2)
Fuel consumption ² , mpg (l/100km) Combined	19.6 (14.4)	22.4 (12.6)	19.0 (14.9)	21.2 (13.3)
ABI insurance group, 1-50 ⁺	50 E	50 E	50 E	50 E
Unladen weight ⁴ , kg	1660	1685	1720	1745
Gross weight limit, kg	1960	1985	2020	2045
Luggage compartment capacity, rear seats upright, litres	100	100	100	100
Fuel tank capacity approx, litres	80	80	80	80
Emission standard	EUS	EUS	EUS	EUS

*Highest insurance group rating shown. Group may be lower dependent on trim level. Please visit www.thatcham.org/abigrouprating for details.

¹The given value was obtained in accordance with the specified measurement procedure (the respective current version of the Directive 80/1269/EEC).

²Fuel consumption and CO₂ emissions figures are obtained under standardised test conditions (Directive 93/116/EEC) using a representative model. This allows direct comparison between different models from different manufacturers, but may not represent the actual fuel consumption achieved in 'real world' driving conditions. More information is available at www.vca.gov.uk.

³Top speed is achieved in top gear.

⁴Vehicle's unladen weight without driver (calculated in accordance with the current version of Directive 80/1268/EEC). The fitting of additional equipment may increase the vehicle's unladen weight and drag coefficient, whereupon the potential carrying capacity and top speed will be correspondingly reduced.

R8 V8 Coupé dimensions

The technical drawings opposite show the exact dimensions of the R8 V8 Coupé, so you can check everything from your car's ground clearance to its length.

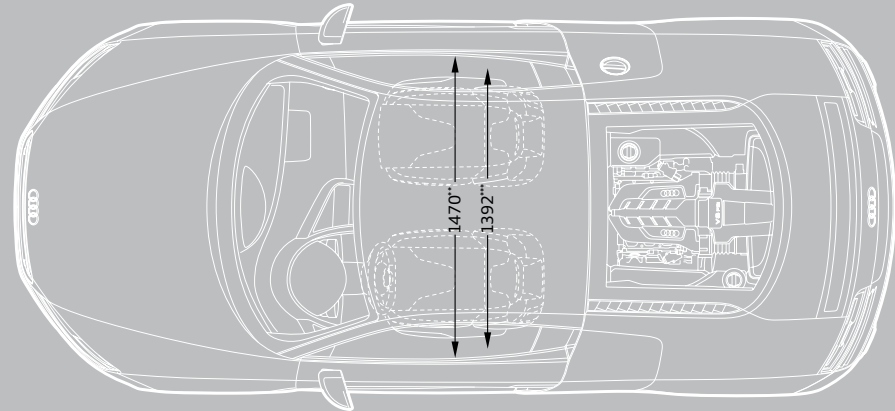
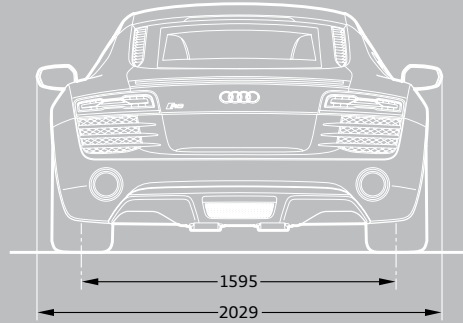
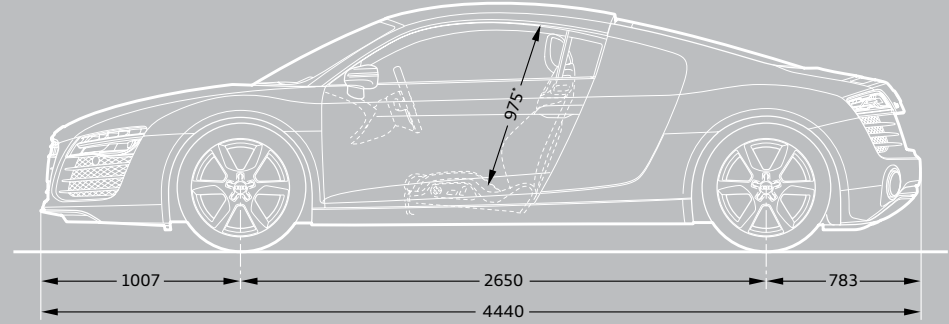
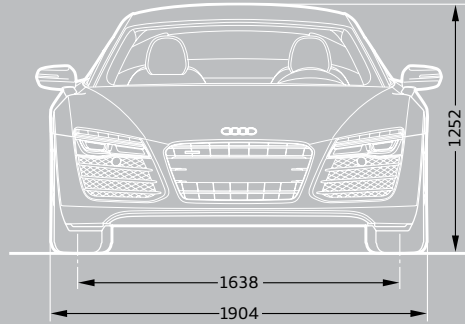

- *Maximum headroom
- **Elbow room width
- **Shoulder room width

Dimensions measured with vehicle at unladen weight, ground clearance measured with vehicle carrying its maximum load.

Turning circle approx 11.4m.

Dimensions in millimetres.

R8 V10 and V10 plus Coupé dimensions

The technical drawings opposite show the exact dimensions of the R8 V10 and V10 plus Coupé, so you can check everything from your car's ground clearance to its length.

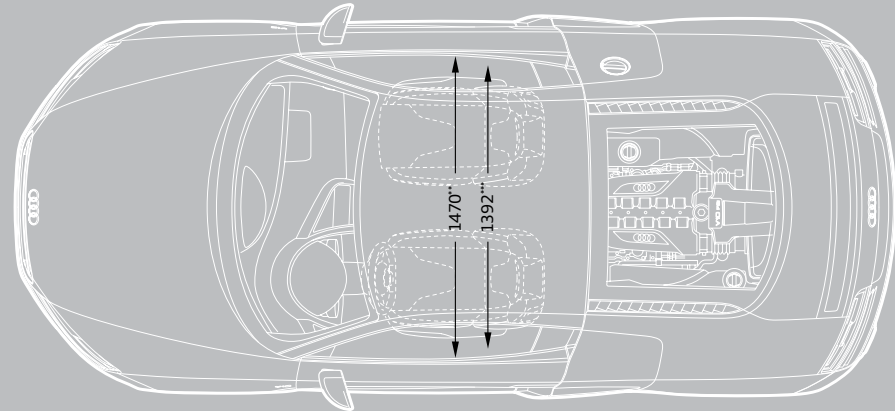
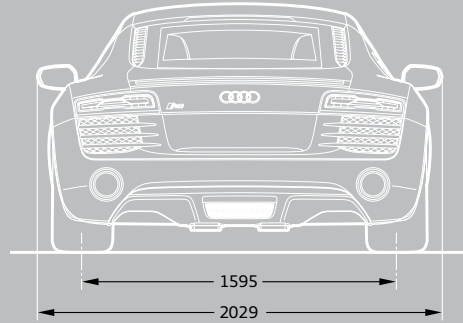
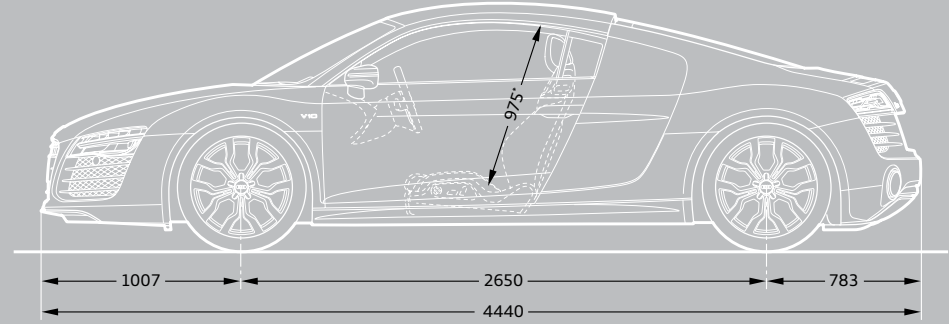
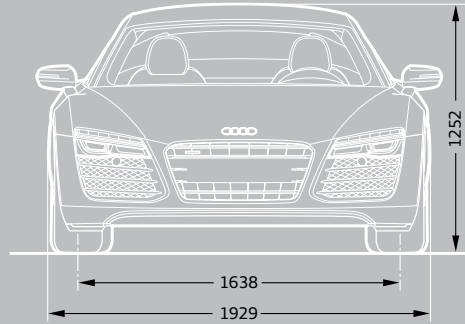

- *Maximum headroom
- **Elbow room width
- ***Shoulder room width

Dimensions measured with vehicle at unladen weight, ground clearance measured with vehicle carrying its maximum load.

Turning circle approx 11.4m.

Dimensions in millimetres.

R8 V8 Spyder dimensions

The technical drawings opposite show the exact dimensions of the R8 V8 Spyder, so you can check everything from your car's ground clearance to its length.

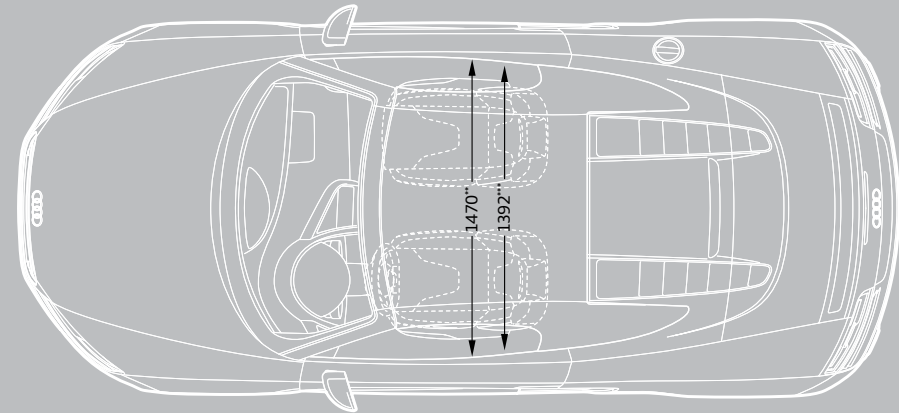
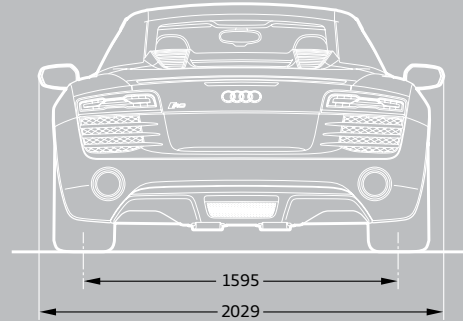
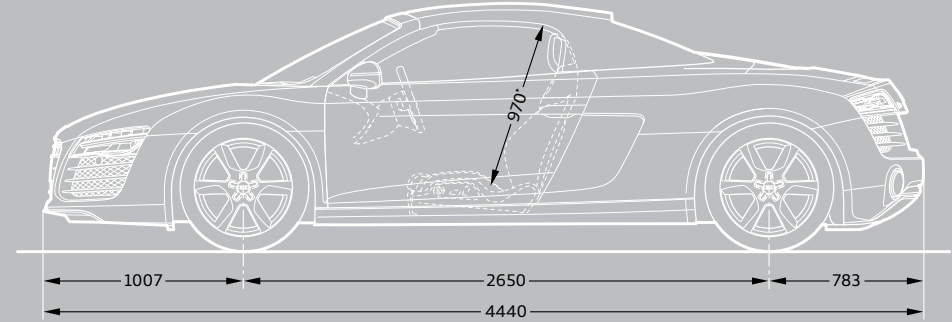
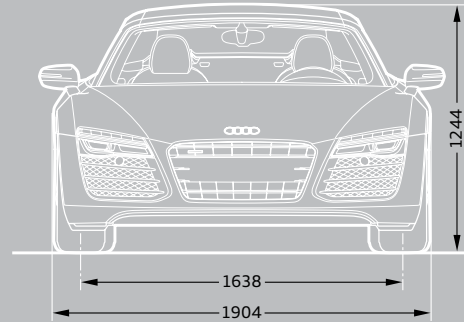

- *Maximum headroom
- **Elbow room width
- **Shoulder room width

Dimensions measured with vehicle at unladen weight, ground clearance measured with vehicle carrying its maximum load.

Turning circle approx 11.4m.

Dimensions in millimetres.

R8 V10 Spyder dimensions

The technical drawings opposite show the exact dimensions of the R8 V10 Spyder, so you can check everything from your car's ground clearance to its length.

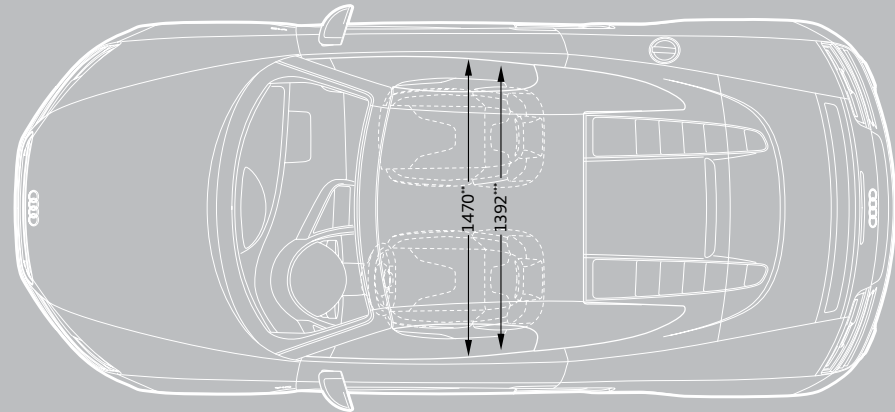
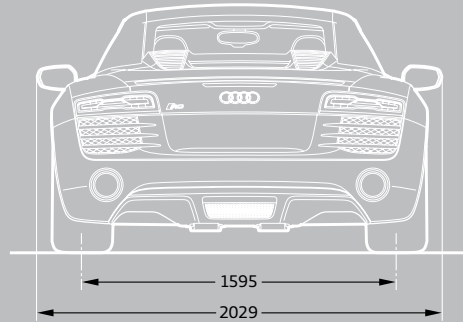
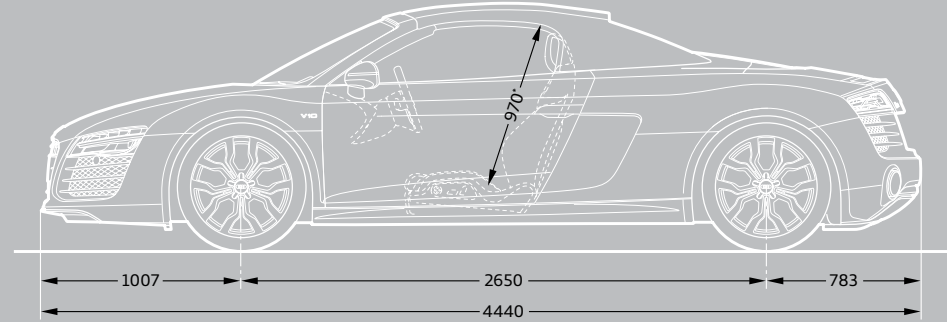
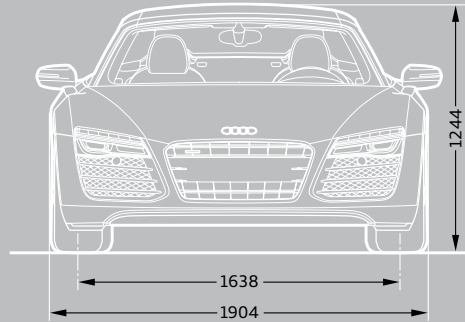

*Maximum headroom
**Elbow room width
***Shoulder room width

Dimensions measured with vehicle at unladen weight, ground clearance measured with vehicle carrying its maximum load.

Turning circle approx 11.4m.

Dimensions in millimetres.

Pricing and Additional information

Welcome to Audi

By placing an order for your Audi, you're choosing to get behind the wheel of one of the most sophisticated cars on the road. And because we believe the service we offer should be just as advanced, we want to let you know exactly what you can expect from us, now and in the future.

We've agreed a set of standards with all our Centres which governs the way we do business with you. It outlines the kind of service we promise to deliver for every customer, right down to filling each new Audi we sell with half a tank of fuel.

So whether you're interested in the date your car will arrive in the UK or the way we'll dispose of non-biodegradable materials after we service your Audi, you can have total confidence in us.

Audi Promise

Audi Centres

We guarantee that all our Centres will be open as follows:

Sales: Monday to Friday 9am–6pm
Saturday 9am–5pm

Service: Monday to Friday 8am–6pm
Saturday 8.30am–1pm

Sunday opening is at local discretion.

New car delivery

Once we've confirmed a delivery date for your car, we'll keep you informed of progress. Subject to reasonable notice, we'll then deliver it to a place of your choice, whether that's your home or work. In the unlikely event of a delay, we'll provide a courtesy car to minimise inconvenience and keep you mobile.

Environmental commitment

We promise to dispose of all non-biodegradable materials from your vehicle in a responsible manner.

Pricing

Prices and specifications given are correct at the time of printing. Always check details with your Audi Centre as Audi policies are continually developing. We reserve the right to change prices or specifications at any time.

All prices are subject to VAT, currently charged at 20%, but this may alter to reflect any change in the applicable VAT rate.

Delivery charges and number plates are not included in the vehicle price.

Delivery charge	£471.66
Number plate	£20.00
VAT	£98.34
Total	£590.00

Audi Customer Care

Every new Audi benefits from the comprehensive Audi Customer Care Package, which comprises:

- ▶ A 3-year Audi warranty, which covers you for unlimited mileage in the first 2 years of ownership, with a full mechanical and electrical warranty which covers you for up to 60,000 miles in the 3rd year
- ▶ A 3-year paint warranty
- ▶ A 12-year anti-corrosion warranty
- ▶ 3 years' UK roadside assistance and recovery

You also have the option when ordering your new car of choosing a 4-year or 5-year Audi warranty. Speak to a member of the sales team for more information.

Audi tax-free sales

If you are entitled to purchase a vehicle free of VAT, normally through military or diplomatic privilege, please contact your local Audi Centre for full details.

Should you have any difficulty obtaining the information you require, please call Freephone 0800 585878.

Audi Finance

Audi Finance specialises in providing funding solutions for Audi drivers. Whether your Audi is for private or business use, there is a range of funding options to choose from.

Below is the full range of finance products, which comprises:

- ▶ Solutions – a Personal Contract Plan
- ▶ Hire purchase
- ▶ Lease purchase
- ▶ Finance lease
- ▶ Contract hire

With all products, you can choose a fixed-cost maintenance plan designed to help you budget accurately.

No matter which Audi model you choose, your local Audi Centre can provide you with a personalised quote designed to fit your budget and motoring needs.

Audi Finance is a trading name of Volkswagen Financial Services (UK) Limited. An offer of finance depends on certain conditions. Available to people over 18 in the UK only.

Audi Insurance

We want you to start enjoying your new car from day one and thanks to Audi Insurance complimentary 7-day cover, you can. Call free on 0800 316 7893 (lines are open Monday to Friday 8am–9pm, and Saturday 9am–5pm), provide a few details and a cover note will be sent to your Audi Centre. They will then tax your car and you can drive it away.

Additional information

CO₂ data and information

CO₂ emissions-based Vehicle Excise Duty

Vehicle Excise Duty (Road Fund Licence) is based upon the amount of Carbon Dioxide (CO₂) a vehicle emits, measured in grams per kilometre (g/km). First year VED rates apply to the first year of ownership. Annual VED rates apply thereafter. The DVLA has created thirteen categories:

Petrol and Diesel engines	First year	Annual rate (second year onwards)
A – up to 100g/km	£0.00	£0.00
B – 101 to 110g/km	£0.00	£20.00
C – 111 to 120g/km	£0.00	£30.00
D – 121 to 130g/km	£0.00	£105.00
E – 131 to 140g/km	£125.00	£125.00
F – 141 to 150g/km	£140.00	£140.00
G – 151 to 165g/km	£175.00	£175.00
H – 166 to 175g/km	£285.00	£200.00
I – 176 to 185g/km	£335.00	£220.00
J – 186 to 200g/km	£475.00	£260.00
K – 201 to 225g/km	£620.00	£280.00
L – 226 to 255g/km	£840.00	£475.00
M – over 255g/km	£1,065.00	£490.00

Vehicle Excise Duty (VED) rates correct at time of going to print, but these may alter to reflect any change in the applicable VED rate.





Audi UK

Customer Services
Selectapost 29
Sheffield
S97 3FG
0800 699888
audi.co.uk

Specifications and prices subject
to change without notice.

© Audi UK

Printed in the UK
Edition 2.0 05/13
2014 model year

Images are for illustrative purposes only.

