



Aus Liebe zum Automobil

The Golf



Greater safety. Different driving situations require alternative solutions, so we've developed electro-mechanical servo steering to make driving safer and more comfortable. When you're reversing into a parking space, the steering is light and responsive.

However, if you're cruising along a motorway, sensors will detect a whole new scenario. The solution is to create the optimum servo support that results in stability at speed, but a precise response should you need to make a sudden change of direction.



More comfort. Whether you're faced with town driving or winding country roads, the Golf provides great roadholding through its totally revised suspension system. It features an optimised McPherson front axle and a broader track for improved stability. Stabilisers are situated directly at the suspension strut which helps minimise roll at the front axle. Furthermore, the dampers and suspension work independently of one another to protect the driver and passenger from bumpy roads and potholes.

For challenging road surfaces, there's an easy solution.

4MOTION. A sophisticated four wheel drive system which allows the engine power to be transferred to the wheels with the best traction. The system constantly regulates the distribution of the drive between front and rear axles and because the system is electronically controlled, it gives the optimum traction for all driving situations.



Improved dynamics. When it comes to performance roadholding, the Golf delivers through a four-link rear axle. A highly effective arrangement allows the length and cross dynamics to be tuned separately with great results. Even through tight corners the Golf is extremely stable with minimal sideways roll. In fact, you'll soon appreciate the rear axle benefits on every road surface you encounter. From uneven tracks to motorway cruising, you'll feel just one thing – pure driving pleasure.

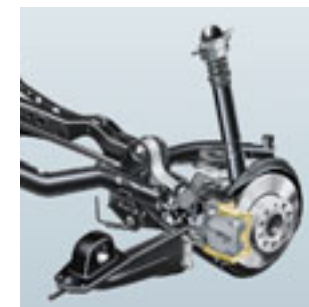

01

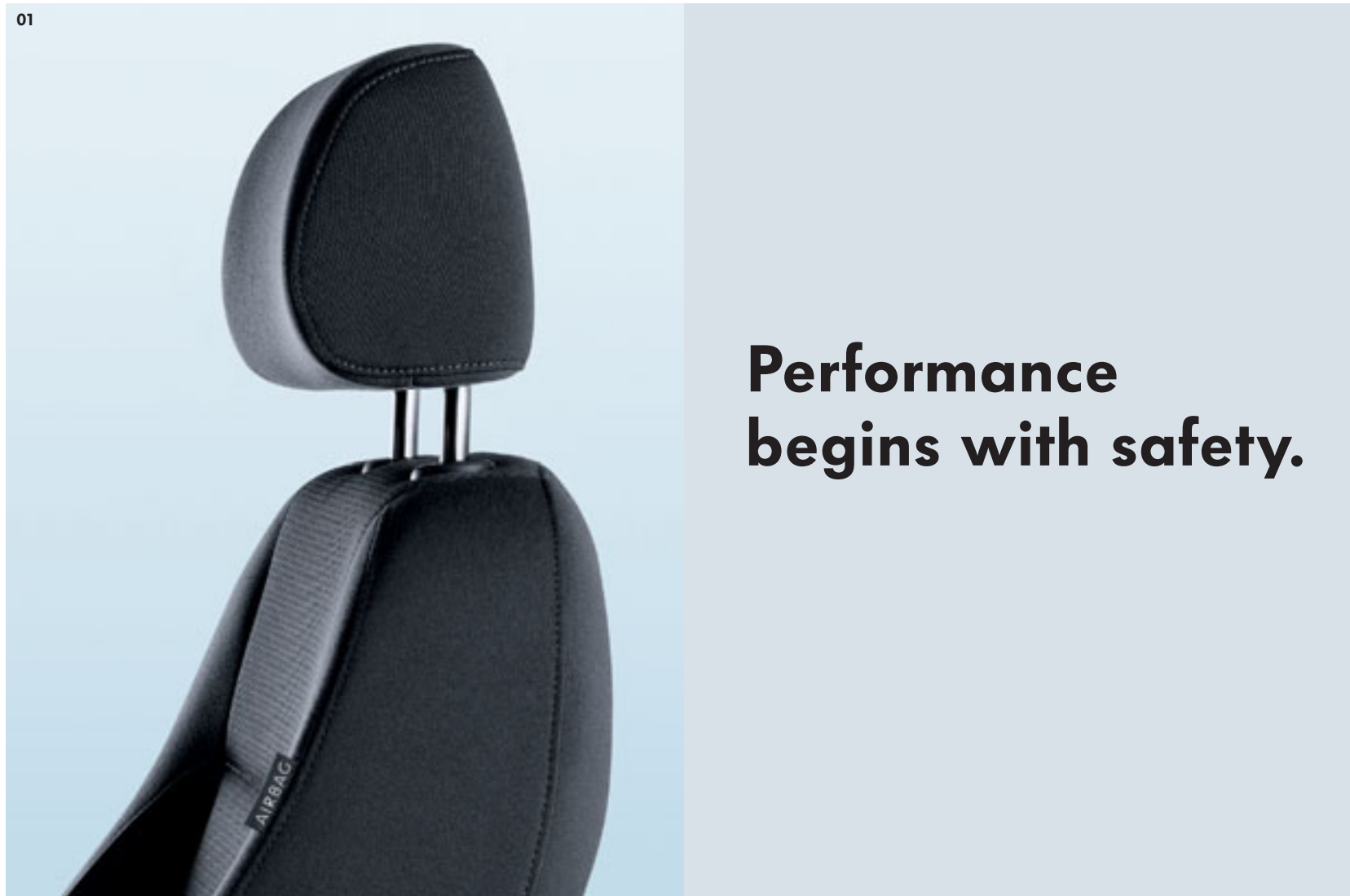

Performance begins with safety.

The concept of safety is fundamental to the Golf philosophy, so it's not surprising the Golf achieves a five star NCAP safety rating. To start with, the Golf is constructed around an extremely rigid bodyshell that has been crafted using state-of-the-art laser welding techniques. This results in a structure that is so strong, it can absorb impact energy and thereby protect the driver and passengers within a protective inner cell. There's also an abundance of airbags; two front airbags, two front side impact airbags and two curtain airbags. Airbags have been one of the most important breakthroughs in driver and passenger safety, so it's no surprise to find that Volkswagen have invested so heavily in their development and usage in order to maximise protection.

A new safety development has been the adaptation of the front head restraints. Following an impact from the rear, the new

whiplash-optimised front head restraints help minimise whiplash injuries to the neck and spine.

An innovative Isofix child seat mounting system allows children's seats, equipped with the Isofix system, to be fitted securely to the Golf's body via eyes between the rear seat backrest and seat base. Child seats with the Isofix system can be purchased from your Volkswagen retailer.

Passive safety features are those that reduce injuries once an accident has occurred, with seat belts being a good example. In the Golf you'll find three-point seat belts for all seats, seat belt pre-tensioners for the front seats and three head restraints for the rear seat passengers. There's even a warning light to remind the driver and front seat passenger to fasten their seat belt.

Active safety features, are those that can help you avoid an accident in the first place. Once again, the Golf boasts several key examples – such as Traction Control (ASR) that can help avoid wheelspin in slippery conditions and a sensor-controlled Electronic

01 Whiplash-optimised front head restraints: Help to reduce whiplash injuries to the neck and spine.

02 ESP: The sensor-controlled Electronic Stabilisation Programme recognises critical driving situations and reacts in milliseconds by controlling the speed of individual wheels.

03 ABS: The Anti-lock Braking System works in conjunction with an Electronic Differential Lock (EDL). Even under emergency braking, this formidable combination helps prevent the wheels from locking, thereby allowing the driver to steer around hazardous objects.

04 Airbags: Every Golf benefits from six airbags for all-round protection. The front passenger airbag can also be deactivated if required.



Stabilisation Programme (ESP). ESP detects critical situations at an early stage and takes action, for example, by specifically braking individual wheels helping to bring the vehicle under control. So whether it's a tight bend or loose road surface, ESP will help you stay safely on course. Though such innovative systems are highly effective, it's worth remembering that they cannot dispense with the laws of physics.

ESP is supported by disc brakes all round with the front being ventilated, an integrated brake assistant which recognises an emergency braking situation and increases braking effort and an Anti-lock Braking System (ABS). These systems combine to deliver impressive stopping distances, yet they still allow the driver to steer around hazardous objects. In addition, under emergency braking the hazard lights are automatically activated which provide additional warning to other drivers. It's not only Golf drivers who can depend on the Golf, but everybody who encounters it.

Model shown is Golf Sport with optional 17" 'Indianapolis' alloy wheels and metallic paint.

Models shown are Golf SE with optional 17" 'Torino' alloy wheels and SE with optional 16" 'Hockenheim' alloy wheels. Both models feature optional metallic paint.



With numerous models and engines, the choice is yours.

A great design is one that stirs enthusiasm at first sight. So as you cast your eye over the Golf, you'll witness a whole host of features to raise your adrenaline. Compared with its predecessor, you'll notice its wider track, longer wheelbase and larger wheels which provide a more powerful and dynamic appearance.

It's not just first impressions though where the Golf excels. Look a bit closer and it becomes apparent how cleverly the individual design elements combine and complement one another for both aesthetic and functional purposes. For example, the way the aerodynamically styled door mirrors house additional indicator lights for

greater safety. Or the way the front fog lights sit neatly within the front bumper on the Golf GT and GTI.

Thanks to the high quality materials and construction, it's reassuring to know that the Golf's galvanised bodywork is covered against rusting through from the inside by an impressive

12-year warranty. The exceptional build quality is also evident in the optimum fit of the panels which meet with consistently narrow gaps. There are many reasons to admire the Golf, so discover more over the next few pages.

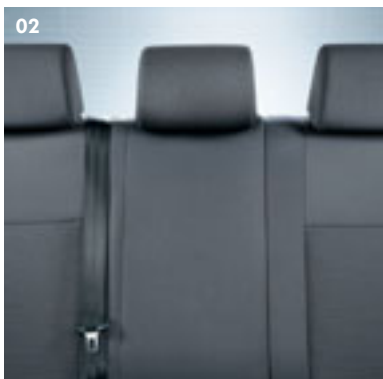

01 Convenient: Split-folding rear seats can be folded down for clever use of space for those larger objects.

02 Safe: Three-point automatic seat belts and three head restraints, provide optimum protection for rear seat passengers.

03 Sound: The radio/CD player with four front speakers will ensure maximum enjoyment on any journey.

04 Stylish: User-friendly design ensures all the dials and controls are optimally located and within reach. A choice of high quality materials creates a refined interior.



The Golf S

The Golf S may be the entry model but it's far from basic. The Golf has many exceptional qualities, highlighted by its attention to practical detail. It's the reason why standard equipment includes split folding rear seats, electrically heated and adjustable door mirrors, electric front windows, 'Climatic' semi-automatic air conditioning – which also cools the glovebox, a radio/CD player with four front speakers and a luggage compartment which is illuminated to help you find things after dark. There's also remote control central locking and an electronic engine immobiliser to help protect against theft.

The ergonomically designed seats are covered in stylish and durable 'Media' design material. For the driver, there's a height-adjustable seat and a height and reach adjustable steering column to help achieve a really comfortable driving position. If you choose a three door model, you'll find 'easy entry' seats make access to and from the rear seats a simple task. In line with our commitment to safety, there are whiplash-optimised front head restraints, six airbags, ESP (Electronic Stabilisation Programme) and three-point seat belts for the driver and all four passengers. We've also thought about the youngest passengers. The Golf is fitted with a front passenger's airbag deactivation switch should you need to use a rear facing child seat in the front. It's also fast and simple to add one or two child seats to the rear passenger area. Not just any child seat, but an Isofix child seat – the innovative concept from Volkswagen that ensures child seats are more sturdy and secure for greater protection.

The Golf SE

The **Golf SE** builds on the introductory Golf S adding a higher specification for a little touch of luxury. It has 'Opera' loop-velour upholstery and height-adjustable front seats with lumbar support. The interior benefits from an overhead storage compartment for your sunglasses, storage pockets in the back of the front seats and a load-through provision in the rear seats for any long items you might wish to carry.

A multifunction computer provides useful statistics about your journey including exterior temperature, average and current fuel consumption and average speed of your journey. Cruise control becomes standard, so on a motorway journey you can set your desired speed, take your foot off the accelerator and let your Golf SE cruise along until you either touch the brake or clutch.

For additional convenience the SE also comes with an automatic dimming interior rear-view mirror, a rain sensor which activates the windscreen wipers, a dusk sensor which will automatically switch on the headlights as light levels fall, and a delayed lighting switch which keeps the lights on for a short period of time after you exit your vehicle to help you find your way in the dark.

There's also an alarm with interior protection, a radio/CD player with eight speakers, front and rear electric windows and finally, 15 inch 'Misano' light alloy wheels to ensure your Golf SE has a distinctive look.



01 Detail: The interior of the Golf SE. Interior shown has optional front centre armrest with storage compartment.

02 Stylish: The 15" 'Misano' alloy wheels on the Golf SE provide an exclusive look.

03 Relaxing: A simple push of a button will activate the cruise control and hold a desired speed whether you go uphill or downhill.

04 Important: The multifunction display keeps you up to date with information about your journey.



01 Distinctive: 16" 'Mugello' alloy wheels are fitted as standard and add to the Sport's appeal. Model shown is Sport with optional metallic paint.

02 Important: The multifunction display keeps you up to date with details about your journey.

03 Perfect handling: The leather trimmed three-spoke steering wheel underlines the dynamics of the Sport.

04 Sound: The radio/CD player with eight speakers provides excellent sound quality. Comfort: 'Climatic' semi-automatic air conditioning provides year round comfort.

05 Safe: The added stability and safety provided by the 4MOTION system which is standard on Sport TDI 4MOTION.

The Golf Sport

The Golf Sport. For those who appreciate high standards of luxury and technological refinement, combined with a design which provides a powerful and dynamic appearance, the Golf Sport is designed to deliver.

Aesthetically the Golf Sport offers that little bit extra, with body-coloured bumpers, bump strips, side bump strips and door handles giving a sleek, streamlined look. Distinctive 16 inch 'Mugello' alloy wheels and lowered sports suspension complete the exterior picture, providing the finishing touches to a car that will more than live up to your expectations.

Step inside the Golf Sport and prepare to be impressed. The superior specification includes front sports seats with height and lumbar adjustment, and a leather trimmed three-spoke steering wheel, gear knob and handbrake grip.

'Climatic' semi-automatic air conditioning, a multifunction computer and a radio/CD player with eight speakers will ensure maximum enjoyment on any journey.

In addition, if you prefer the added stability and safety provided by four wheel drive, you could specify the Sport TDI 4MOTION. Volkswagen's sophisticated four wheel drive system allows the engine power to be transferred to the wheels with the best traction. The system gives the optimum traction for all driving situations and adds to the already high levels of driver and passenger safety, even in the most demanding conditions.



01

The Golf GT

The **Golf GT** provides immense satisfaction, even before you've ventured out on to the road. The dynamic appeal runs throughout with a high exterior and interior specification. From the outside, you'll notice the GT styling with uniquely shaped front bumper, front fog lights and 17 inch 'ClassiXs' light alloy wheels, and that the car sits lower on the road due to its sports suspension. The GT, powered by either of the 170 PS engines, is further distinguished by a twin exhaust tailpipe.

Step inside and you'll be equally impressed by the front sports seats with 'Brick' upholstery, complemented by 'Smooth Black' decorative inserts in the dash and centre console, and finished off with leather trim across the three-spoke steering wheel with GT logo, gear knob and handbrake grip.

On the safety and security front, the Golf GT has many appealing features. These include an automatic dimming interior rear-view mirror, to stop you from being dazzled by the headlights of a following car, a dusk sensor that will automatically switch the headlights on and a delayed lighting switch so that when you arrive home at night-time the lights will remain on for a short period of time to help you find your way in the dark. The windscreen wipers are activated by a rain sensor and react depending on the amount of rainfall.



02

01 Perfect handling: The leather trimmed three-spoke steering wheel with GT logo underlines the dynamics of the Golf GT. Interior shown has optional DVD satellite navigation system including front centre armrest, and 2Zone electronic climate control.

02 Detail: An exclusive GT badge on the front grille gives the GT a distinctive sporty look.

03 Sporty: The fitment of 17" 'ClassiXs' alloy wheels with 225/45 R17 tyres on the Golf GT is part of its character and appeal.

04 Stylish: The GT styling pack featuring a uniquely shaped front bumper with front fog lights completes the look. Exterior shown has optional gas discharge (Bi-Xenon) dipped and main beam headlights.

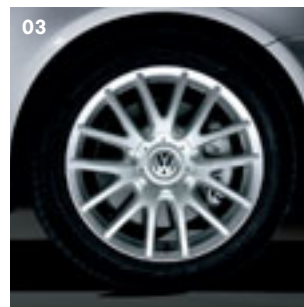

03



04



01

01 Unique: Front sports seats in 'Interlagos' cloth upholstery enhance the Golf GTI's distinctive look.

02 Sporty: The chrome twin exhaust tailpipe hints at the sporting intent of the Golf GTI.

03 Stylish: The race-inspired leather trimmed three-spoke steering wheel with GTI logo adds the finishing touch to your GTI experience. The radio system RCD 500, multifunction computer (Highline) and Winter pack are optional at extra cost.

04 Legendary: The Golf GTI, based on the original philosophy and produced to the same legendary build quality.



02

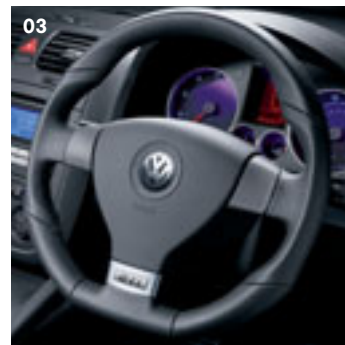

03



04

The Golf GTI

The Golf GTI. The original, updated. Taking a huge evolutionary step forward, the Golf GTI has been redefined to deliver energy, excitement and exhilaration.

Demonstrating technological advancement, the Mark V Golf GTI is powered by a new 16-valve direct injection 2.0 litre T-FSI turbocharged unit. Developing a phenomenal 200 PS at just 5,000 rpm and a hefty 280 Nm of torque from only 1,800 rpm, the engine can be linked to the six speed manual gearbox or a DSG automatic. When specified with the DSG automatic gearbox, the GTI comes with a superb paddle shift steering wheel. This allows gear shifts to be selected using paddles on the back of the steering wheel when driving with the gearbox in tiptronic mode. The FSI technology utilised in the new engine provides a double-edged advantage – power and economy.

At first glance the message is clear – the original GTI is back. The essence of GTI styling is recognisable by its chrome twin exhaust tailpipe, wide track lowered sports suspension and 17 inch 'Monza' alloy wheels. Settle deep into the front sports seats with height and lumbar adjustment, hold onto the race-inspired leather trimmed three-spoke sports steering wheel and feel the excitement begin.



01



02



03



04

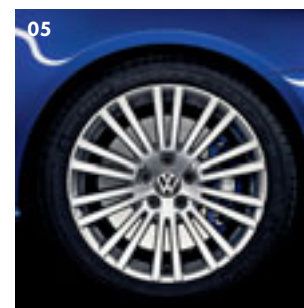

05

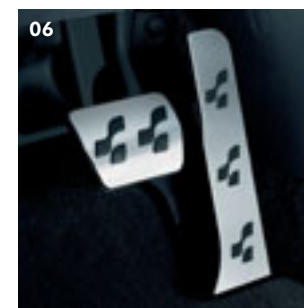

06

The R32. Pure energy.

The Golf R32 will get your heart beating as no other car can. Inspired by the technology and temperament of motorsport, this phenomenal car delivers all the dynamic handling, exhilaration and excitement you could ask for, along with the class-leading performance and sheer driving enjoyment you'd expect from the fastest ever Golf.

The Golf R32 is powered by an exceptional 3.2 litre V6 petrol engine, capable of generating a phenomenal 250 PS, and producing a hefty 320 Nm of torque at just 2,800 rpm. Coupled with a slick six speed manual gearbox, the V6 engine can accelerate the R32 from 0 - 62 mph in an impressive 6.5 seconds. Alternatively, it can be coupled with the superb automatic DSG gearbox, which allows super-swift gear changes without interrupting the acceleration of the car under power, resulting in a 0 - 62 mph time of just 6.2 seconds.

The Golf R32 is fitted with the sophisticated 4MOTION four wheel drive system, whereby power is redistributed to the wheels that need it most, ensuring all four wheels work in harmony. The result is greater traction, improved safety and added driving pleasure, on any type of road.

Inside you'll notice a comprehensively equipped interior. Deep front sport seats, 2Zone electronic climate control, an eight speaker radio/CD player, rain sensor and automatic dimming interior rear-view mirror, automatic coming/leaving home lighting function and dusk sensor combine to produce a luxurious interior specification with great attention to detail.

01 Awesome: The Golf R32 with optional DVD navigation/radio system and pearl effect paint.

02 Luxurious: The Golf R32 automatic DSG with multifunction steering wheel. The radio system RCD 500, telephone preparation and Winter pack are optional at extra cost.

03 Ergonomic: The three-spoke multifunction leather trimmed steering wheel with paddle shift allows control of the radio and multifunction computer without taking your hands off the wheel. Standard when specified with the DSG gearbox.

04 Unique: Twin exhaust tailpipes, more than just hint at the sporting prowess of the R32 and are a unique styling feature.

05 Impressive: The braking system comprises large dimensioned discs to both front and rear, the front being internally ventilated, while blue brake calipers are clearly visible behind the 18" 'Zolder' alloy wheels complete with 225/40 R18 tyres.

06 Race-inspired: Aluminium-look foot pedals are designed for performance, looks and safety.

Paint.



* Metallic and pearl effect paints are optional at extra cost.

¹ Candy White (B4) non-metallic paint is only available for the GTI.













² Please note that Candy White (B4), Ink Blue (D3) non-metallic, New River Blue (2J) metallic and Blue Graphite (W9) pearl effect paints are not available for the R32.

³ Please note that New River Blue (2J) metallic and Deep Blue pearl effect (6X) paints are not available for the GTI.

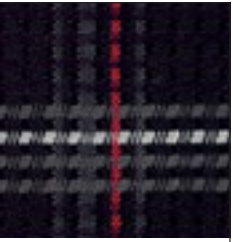
⁴ Deep Blue (6X) pearl effect paint is only available for the R32.

Please note: Screen technology does not allow exact reproduction of the paint colours.

Upholstery.

<p>'Media' cloth</p> <p>Standard – S</p>	 <p>Anthracite (HA)</p>	 <p>Art Grey (HC)</p>	<p>'Opera' loop-velour</p> <p>Standard – SE</p>	 <p>Anthracite (JS)</p>	 <p>Art Grey (JT)</p>
<p>'Siempre' cloth</p> <p>Standard – Sport</p>	 <p>Anthracite (KG)</p>	 <p>Art Grey (KH)</p>	<p>'Brick' cloth</p> <p>Standard – GT</p>	 <p>Anthracite (RS)</p>	
<p>'Interlagos' cloth</p> <p>Standard – GTI</p>	 <p>Anthracite (RZ)</p>	<p>'Monte Carlo' cloth</p> <p>Standard – R32</p>	 <p>Anthracite (WT)</p>		
<p>'Vienna' leather*</p> <p>Optional – SE, Sport, GT</p>	 <p>Anthracite (TG)</p>	 <p>Beige (TH)^{1,2}</p>	<p>'Vienna' leather*</p> <p>Optional – GTI, R32</p>	 <p>Beige (TH)^{1,3}</p>	 <p>Anthracite (TK)</p>

* Some parts of leather seats will contain artificial leather.

¹ With Beige (TH) the interior trim and roof lining are colour co-ordinated to the upholstery colour.

² Not available on GT models.

³ Not available on R32 models.

Please note: Screen technology does not allow exact reproduction of the upholstery colours.

Colour combinations.

	Seat upholstery	Carpets	Dashboard	Black (A1)	Candy White (B4) ^{1,2}	Ink Blue (D3) ²	Tornado Red (G2)	Shadow Blue metallic* (P6)	Steel Grey metallic* (X6)	New River Blue metallic* (2J) ^{2,3}	Reflex Silver metallic* (8E)	Blue Graphite pearl effect* (W9) ²	Diamond Black pearl effect* (Z4)	Deep Blue pearl effect* (6X) ^{3,4}
'Media' cloth upholstery Standard on S	Anthracite (HA)	Black	Anthracite	•		•	•	•	•	•	•	•	•	
	Art Grey (HC)	Black	Anthracite	•		•	•	•	•	•	•	•	•	
'Opera' loop-velour upholstery Standard on SE	Anthracite (JS)	Black	Anthracite	•		•	•	•	•	•	•	•	•	
	Art Grey (JT)	Black	Anthracite	•		•	•	•	•	•	•	•	•	
'Siempre' cloth upholstery Standard on Sport	Anthracite (KG)	Black	Anthracite	•		•	•	•	•	•	•	•	•	
	Art Grey (KH)	Black	Anthracite	•		•	•	•	•	•	•	•	•	
'Brick' cloth upholstery Standard on GT	Anthracite (RS)	Black	Anthracite	•		•	•	•	•	•	•	•	•	
'Interlagos' cloth upholstery Standard on GTI	Anthracite (RZ)	Black	Anthracite	•	•	•	•	•	•		•	•	•	
'Monte Carlo' cloth upholstery Standard on R32	Anthracite (WT)	Black	Anthracite	•			•	•	•		•		•	•
'Vienna' leather* Optional on SE, Sport, GT	Anthracite (TG)	Black	Anthracite	•		•	•	•	•	•	•	•	•	
	Beige (TH) ^{5,6}	Black	Anthracite	•		•		•	•			•	•	
'Vienna' leather* Optional on GTI	Beige (TH) ⁵	Black	Anthracite	•		•		•	•			•	•	
	Anthracite (TK)	Black	Anthracite	•	•	•	•	•	•		•	•	•	
'Vienna' leather* Optional on R32	Anthracite (TK)	Black	Anthracite	•			•	•	•		•		•	•

* Metallic and pearl effect paints and leather are optional at extra cost. Some parts of leather seats will contain artificial leather.

¹ Candy White (B4) non-metallic paint is only available for the GTI.

² Please note that Candy White (B4), Ink Blue (D3) non-metallic, New River Blue (2J) metallic and Blue Graphite (W9) pearl effect paints are not available for the R32.

³ Please note that New River Blue (2J) metallic and Deep Blue (6X) pearl effect paints are not available for the GTI.

⁴ Deep Blue (6X) pearl effect paint is only available for the R32.

⁵ With Beige (TH) the interior trim and roof lining are colour co-ordinated to the upholstery colour.

⁶ 'Vienna' leather Beige (TH) upholstery is not available on GT models.

Optional equipment.



01 Leather* not only looks great, it's durable and easy to maintain. The leather upholstery option features heated leather front sports seats with preset temperature settings. Included in this option is a leather trimmed three-spoke steering wheel, gear knob and handbrake grip, which is standard on Sport, GT, GTI and R32 models, to complete the look.

* Some parts of leather seats will contain artificial leather.

Electrically-adjustable lumbar support for the driver's seat is included in the leather upholstery option. This four-way lumbar support function is designed for comfort and support by providing greater and easier adjustment. Also included in this option is manual lumbar adjustment for the front passenger's seat.

Optional on SE, Sport, GT, GTI and R32 models.

Whether you decide on a Golf S, SE, Sport, GT, GTI or R32 you have a choice to enhance it even further with our wide range of optional equipment. By choosing from our Winter or Luxury packs, sumptuous leather upholstery, radio system upgrade or cruise control, just imagine how you could build a car to your personal specification.



02 The tilt and slide electric glass sunroof is extremely easy to use. Simply turn the automatic function to your desired setting. It also includes a sunblind for added comfort. On S models this option includes driver's and front passenger's illuminated sun visor mirrors and two front and two rear reading lights. Optional on all models.



03 The 2Zone electronic climate control is fully automatic to retain a precise internal temperature. It also benefits from a twin zone setting that allows the driver and front passenger up to 4°C difference in their chosen temperature settings. Even the glovebox is chilled should you be carrying snacks on your journey. Optional on S, SE, Sport and GT.

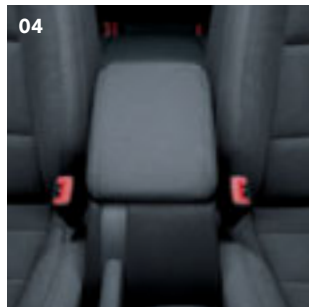

04 The front centre armrest has a handy storage compartment and also provides the rear seat passengers with two rear air vents and cup holders for comfort and convenience. Optional on all models.



05 Radio system RCD 500 including dash-mounted six CD autochanger available with Volkswagen soundpack and ten speakers – six front and four rear – for near perfect acoustics. Optional on all models.

Please note: The radio system RCD 500 and DVD navigation/radio system cannot be specified in conjunction with each other.



06 The DVD satellite navigation system not only delivers perfect sound quality whether you're listening to a CD or the radio, but it can also guide you to your destination in any one of 24 European countries. A 6½" multifunction colour display shows a map of your route along with important information on time and distances. In addition, audible directions can also be broadcast allowing you to concentrate on the road ahead. This option also includes a front centre armrest with six CD autochanger and a Highline multifunction computer. The rear seat passengers are provided with two rear air vents and cup holders conveniently located in the armrest. Optional on all models.



07–08 iPod preparation or USB port – by Individual, mounted in the front centre armrest allows you to link your iPod or MP3 player to the vehicle's audio system via either USB port or iPod preparation, depending on the device. Controls are then provided through the radio keypad or optional multifunction steering wheel. Optional on all models.



Also available but not shown:

Convenience pack includes a coming/leaving home lighting function with automatic headlights on, automatic dimming interior rear-view mirror, rain sensor and front footwell illumination. Not available in conjunction with Luxury packs – 1 or 2. Optional on S and Sport models.

Luxury pack – 1 includes a rain sensor and automatic dimming interior rear-view mirror, electrically foldable door mirrors with reverse activated kerb-view adjustment on the passenger's mirror, dusk sensor which automatically switches the headlights on in poor or fading light, coming home/leaving home surrounding area lighting function and front footwell illumination. Optional on all models.

Telephone preparation links your mobile telephone to the radio aerial, ensuring better reception and less interference, and allows conversations to be relayed via the radio speakers. Optional on all models.

Telephone cradle holds a mobile telephone securely in place. The cradle must be used in conjunction with the telephone preparation option. Please see your Volkswagen retailer for mobile telephone compatibility. Optional on all models.



01 Front fog lights provide added safety when driving in poor weather conditions. Optional on S, SE and Sport models.

07 Multifunction steering wheel (optional on SE, Sport and GT models) is also available as an option with paddle shift for DSG gearbox.

08 Multifunction steering wheel (optional on GTI models) is also available as an option with paddle shift for DSG gearbox.

09 Multifunction steering wheel (optional on R32 models). The multifunction steering wheel with paddle shift is standard on the R32 with automatic DSG gearbox, but is available as an option without paddle shift for the R32 with manual gearbox.

All multifunction steering wheels allow convenient operation of the radio, multifunction computer (Highline) and telephone functions. Please note, telephone preparation and appropriate cradle are required to operate a telephone via the steering wheel.

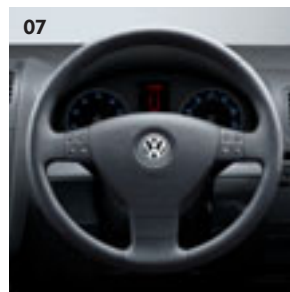

10 'Hockenheim' design 6½J x 16 light alloy wheels with 205/55 R16 tyres. Optional on S and SE models.



11 'Indianapolis' design 7J x 17 light alloy wheels with 225/45 R17 tyres. Optional on SE and Sport models.



12 'Torino' design 7J x 17 light alloy wheels with 225/45 R17 tyres. Optional on SE and Sport models.



02 The storage pack extends the numerous storage facilities to include a drawer under the passenger seat and a luggage net under the rear compartment cover. With this option, S models gain a height-adjustable front passenger's seat. Optional on S, SE, Sport and GT models.



03 Luxury pack – 2 includes the coming/leaving home lighting function. By timer or remote control the headlights and door mirror indicators will illuminate at night-time helping you to find your way in the dark. The pack also includes a rain sensor and an automatically dimming interior rear-view mirror to prevent dazzle from following cars. The exterior door mirrors can be folded back electrically with the driver's door mirror having an automatic dimming function, and the passenger's having a reverse activated kerb-view adjustment. A dusk sensor will automatically switch the headlights on in poor or fading light. Optional on all models.



13 Silver-painted 'Estoril' design 7J x 17 light alloy wheels with 225/45 R17 tyres. Optional on SE and Sport models.



04 The Winter pack offers comfort and safety during the coldest months. The Winter pack includes electrically heated front seats, heated windscreen washer jets, headlight washers and a low washer fluid level warning light. Optional on all models.



14 'Grand Prix' design 7J x 17 light alloy wheels with 225/45 R17 tyres. Optional on SE and Sport models.



05 Cruise control can be set at speeds over 19 mph to maintain a constant speed. So even on long journeys you can have a high degree of relaxation. Optional on S, Sport, GT, GTI and R32 models.



15 'Charleston' design 7½J x 18 light alloy wheels with 225/40 R18 tyres. Optional on GT models.

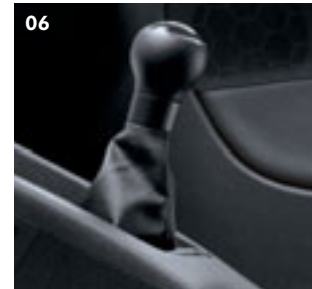

06 The leather trimmed three-spoke steering wheel, gear knob and handbrake grip provide an air of exclusivity. Optional on S and SE models.



16 'Monza II' design 7½J x 18 light alloy wheels with 225/40 R18 tyres. Optional on GTI models.

Also available but not shown:

The alarm with interior protection provides formidable protection through its acoustic and optical features. An electronic engine immobiliser, as well as back-up horn ensure further security. Optional on S models.

Gas discharge (Bi-Xenon) dipped and main beam headlights with automatic adjustment improve visibility and the headlight washer system ensure they stay free from dirt. Optional on SE, Sport, GT and GTI models.

The parking sensor emits an audible beep when reversing, as objects behind get closer, the time between beeps shortens allowing confident parking every time. Also the passenger's mirror has a reverse activated kerb-view adjustment. Optional on all models.

Making light of heavy traffic.

New TSI technology provides two exciting additions to the range – award winning engines that combine power and economy. These ‘Twincharger’ engines feature a mechanically-driven supercharger and an exhaust-driven turbocharger, which in tandem effectively eliminate turbo lag. The belt-driven supercharger operates at low speeds, while the turbocharger activates as the engine speed increases. This results in excellent driveability and performance throughout the range with no turbo lag, continuous power and high maximum torque.

Incorporated into the TSI engines is FSI technology, whereby fuel is injected directly into the combustion chamber under high pressure. The benefit of this method – is that it only burns the exact amount of fuel required helping to reduce fuel consumption and boost performance.

The first variant of the new TSI engine produces 140 PS at 5,600 rpm, offering impressive performance and dynamic power whilst still returning an economical 39.2 mpg on the Combined cycle* and a CO₂ emission of just 169 g/km.

Secondly, a more powerful version is also available, producing 170 PS at 6,000 rpm and torque comparable to that of a typical naturally-aspirated 2.3 litre engine. This helps it sprint from 0-62 mph in just 7.9 seconds, while still offering significantly lower fuel

consumption at 38.2 mpg on the Combined cycle* either with a six speed manual gearbox or with Volkswagen’s revolutionary six speed automatic DSG gearbox. This innovative technology was recognised by the International Engine of the Year Awards where the 170 PS TSI engine was given the prestigious honour of being named ‘Best New Engine of 2006’.

The Golf is also available with four further petrol engines. The first is the 1.4 litre engine which develops 80 PS making it ideal for town traffic or country roads.

There’s also a more powerful 1.6 litre FSI engine that comes with the option of a six speed automatic as well as six speed manual gearbox. This engine not only returns a fuel consumption figure of 40.4 mpg* over the Combined cycle, it also provides healthy performance by generating 115 PS.

The truly exhilarating 2.0 litre turbocharged T-FSI develops 200 PS and, when coupled with the DSG automatic gearbox, can accelerate the Golf GTI from standstill to 62 mph in just 6.9 seconds.

The most powerful engine in the range is the phenomenal 3.2 litre V6 250 PS engine which powers the Golf R32. The V6 unit produces 320 Nm of torque at just 2,800 rpm and is capable of a top speed of 155 mph (where the law permits).



The TDI engines available for the Golf eliminate any compromises – you can have performance as well as exceptional economy*. Such efficiency is due to its direct injection ‘Pumpe Düse’ technology that allows diesel to be injected into the combustion chamber in exact amounts at a unique pressure of 2,050 bar. This not only means impressive performance and low fuel consumption but it also meets the tough EURO 4 exhaust emission legislation.

For example, the 1.9 litre TDI develops 105 PS and 250 Nm of torque. But most impressive is its miserly use of fuel, returning 53.3 mpg* over the Combined fuel cycle. Alternatively, you could choose the 2.0 litre SDI diesel which also benefits from ‘Pumpe Düse’ technology and produces 75 PS. It means the chore of filling up your car becomes something you have to endure less and less.

If you wish for economy*, but with added performance, the 2.0 litre TDI linked to either a six speed manual gearbox or the DSG automatic is sure to satisfy. It generates 140 PS and is one of the strongest in its class when it comes to torque – reaching 320 Nm at just 1,750 rpm. This engine, when coupled with the six speed manual gearbox, on Sport models only, is also available with 4MOTION, the sophisticated four wheel drive system which aids traction and stability.

The latest addition to the diesel range is the 2.0 litre TDI engine which develops 170 PS and an impressive 350 Nm of torque at 1,750 rpm, and is available with a six speed manual or six speed automatic DSG gearbox.

The DSG gearbox offers a genuine alternative to a manual gearbox because it is able to change gear faster than a manual gearbox and more smoothly than a conventional automatic.



* Please see the individual specifications in this section for fuel consumption and CO₂ emissions figures.

S – 1.4 litre 80 PS.

Technical specification.

		Manual	
Engine	Engine type	Four cylinder petrol	
	Cubic capacity, ltrs/cc	1.4/1390	
	Bore/stroke, mm	76.5/75.6	
	Max. output, PS ⁽⁰¹⁾ /kW at rpm	80/59 5000	
	Max. torque, lbs.ft/Nm at rpm	97/132 3800	
	Compression ratio	10.5 : 1	
	Gearbox	Five speed manual	
	Alternator, A	90	
	Battery, A (Ah)	220 (44)	
Weights, kgs	Unladen weight ⁽⁰²⁾	1323	
	Gross vehicle weight	1740	
	Payload ⁽⁰²⁾	417	
	Axle load limit: Front Rear	920 890	
Trailer load limits, kgs⁽⁰³⁾	Braked 12% incline	1000	
	Unbraked	610	
Performance	Top speed (where law permits), mph (km/h)	104 (168)	
	Acceleration, secs 0 - 62 mph	13.9	
	ABI insurance group	4	
Environmental information	Fuel grade, minimum	Unleaded, 95 RON ⁽⁰⁴⁾	
	Fuel tank capacity, galls/ltrs	12.1/55	
	Official fuel consumption, mpg/ltr per 100 km ⁽⁰⁶⁾		
	Urban	29.4/9.6	
	Extra-urban	49.6/5.7	
	Combined	39.8/7.1	
	Official CO ₂ emission, g/km ⁽⁰⁷⁾	170	
	Emission class	EURO 4	
Noise, dB	73.0		

Notes.

- 01) The maximum power output figures are quoted in PS (or Pferdestärke, which is the metric equivalent of horsepower). To convert from metric to imperial horsepower, divide the PS figure by 1.0139.
- 02) Figures are calculated in accordance with manufacturer's criteria. Vehicle unladen weight ranges with 90% tank capacity without driver. The individual unladen weight depends on the specification of the vehicle, this then reduces the possible payload accordingly.
- 03) With increasing altitude the engine performance diminishes. From 1,000 m above sea level and for every 1,000 m thereafter 10% of the vehicle/trailer weight (trailer weight + gross vehicle weight) must be deducted.
- 04) Thanks to the knock control, unleaded four star (at least 95 RON) can be used instead of unleaded Super plus. In order to achieve maximum fuel consumption benefits on the FSI engine, Ultra Low Sulphur Petrol (ULSP) must be used.
- 05) The use of RME and FAME (bio diesel) is not possible.
- 06) Official fuel consumption according to EU Directive 99/94. The consumption calculation according to 1999/100/EC is based on the actual unladen weight of the vehicle. Additional specifications can lead to a higher weight class and hence to consumption figures of this higher weight class. The driving style, road and traffic conditions, environmental influences and vehicle condition can in practice lead to consumption figures, which may differ from those calculated with this standard.
- 07) The weight of a vehicle will influence the level of CO₂ emission it produces; as a result, vehicles with higher levels of specification and factory-fitted options may emit higher levels of CO₂. The CO₂ figure quoted for each vehicle is the maximum possible. The unladen weight of the vehicle is calculated by range at the time of manufacture and the maximum possible CO₂ emission for that weight range is applied according to the Council Directive 80/1268EEC as amended by Commission Directive 1999/100/EC on the approximation of the laws of the member states relating to the carbon dioxide emissions and the fuel consumption of motor vehicles.

S, SE, Sport – 1.6 litre FSI 115 PS.

Technical specification.

		Manual	Automatic
Engine	Engine type	Four cylinder petrol	Four cylinder petrol
	Cubic capacity, ltrs/cc	1.6/1598	1.6/1598
	Bore/stroke, mm	76.5/86.9	76.5/86.9
	Max. output, PS ⁽⁰¹⁾ /kW at rpm	115/85 6000	115/85 6000
	Max. torque, lbs.ft/Nm at rpm	114/155 4000	114/155 4000
	Compression ratio	12.0 : 1	12.0 : 1
	Gearbox	Six speed manual	Six speed automatic*
	Alternator, A	110	110
	Battery, A (Ah)	220 (44)	280 (60)
Weights, kgs	Unladen weight ⁽⁰²⁾	1359	1394
	Gross vehicle weight	1770	1800
	Payload ⁽⁰²⁾	411	406
	Axle load limit: Front	970	1000
	Rear	870	870
Trailer load limits, kgs ⁽⁰³⁾	Braked 12% incline	1200	1200
	Unbraked	620	620
Performance	Top speed (where law permits), mph (km/h)	119 (192)	117 (189)
	Acceleration, secs 0 - 62 mph	10.8	11.5
	ABI insurance group	6	6
Environmental information	Fuel grade, minimum	Unleaded, 95 RON ⁽⁰⁴⁾	Unleaded, 95 RON ⁽⁰⁴⁾
	Fuel tank capacity, galls/ltrs	12.1/55	12.1/55
	Official fuel consumption, mpg/ltr per 100 km ⁽⁰⁶⁾		
	Urban	30.7/9.2	27.2/10.4
	Extra-urban	49.6/5.7	45.6/6.2
	Combined	40.4/7.0	36.7/7.7
	Official CO ₂ emission, g/km ⁽⁰⁷⁾	168	185
	Emission class	EURO 4	EURO 4
Noise, dB	73.0	73.0	

* Not available on Sport.

Notes.

- 01) The maximum power output figures are quoted in PS (or Pferdestärke, which is the metric equivalent of horsepower). To convert from metric to imperial horsepower, divide the PS figure by 1.0139.
- 02) Figures are calculated in accordance with manufacturer's criteria. Vehicle unladen weight ranges with 90% tank capacity without driver. The individual unladen weight depends on the specification of the vehicle, this then reduces the possible payload accordingly.
- 03) With increasing altitude the engine performance diminishes. From 1,000 m above sea level and for every 1,000 m thereafter 10% of the vehicle/trailer weight (trailer weight + gross vehicle weight) must be deducted.
- 04) Thanks to the knock control, unleaded four star (at least 95 RON) can be used instead of unleaded Super plus. In order to achieve maximum fuel consumption benefits on the FSI engine, Ultra Low Sulphur Petrol (ULSP) must be used.
- 05) The use of RME and FAME (bio diesel) is not possible.
- 06) Official fuel consumption according to EU Directive 99/94. The consumption calculation according to 1999/100/EC is based on the actual unladen weight of the vehicle. Additional specifications can lead to a higher weight class and hence to consumption figures of this higher weight class. The driving style, road and traffic conditions, environmental influences and vehicle condition can in practice lead to consumption figures, which may differ from those calculated with this standard.
- 07) The weight of a vehicle will influence the level of CO₂ emission it produces; as a result, vehicles with higher levels of specification and factory-fitted options may emit higher levels of CO₂. The CO₂ figure quoted for each vehicle is the maximum possible. The unladen weight of the vehicle is calculated by range at the time of manufacture and the maximum possible CO₂ emission for that weight range is applied according to the Council Directive 80/1268EEC as amended by Commission Directive 1999/100/EC on the approximation of the laws of the member states relating to the carbon dioxide emissions and the fuel consumption of motor vehicles.

Sport – 1.4 litre TSI 140 PS.

Technical specification.

		Manual	
Engine	Engine type	Four cylinder petrol	
	Cubic capacity, ltrs/cc	1.4/1390	
	Bore/stroke, mm	76.5/75.6	
	Max. output, PS ⁽⁰¹⁾ /kW at rpm	140/103 5600	
	Max. torque, lbs.ft/Nm at rpm	162/220 1500	
	Compression ratio	10.0 : 1	
	Gearbox	Six speed manual	
	Alternator, A	110	
	Battery, A (Ah)	220 (40)	
Weights, kgs	Unladen weight ⁽⁰²⁾	1423	
	Gross vehicle weight	1840	
	Payload ⁽⁰²⁾	417	
	Axle load limit: Front Rear	1020 890	
Trailer load limits, kgs ⁽⁰³⁾	Braked 12% incline	1400	
	Unbraked	660	
Performance	Top speed (where law permits), mph (km/h)	127 (205)	
	Acceleration, secs 0 - 62 mph	8.8	
	ABI insurance group	13	
Environmental information	Fuel grade, minimum	Unleaded, 95 RON ⁽⁰⁴⁾	
	Fuel tank capacity, galls/ltrs	12.1/55	
	Official fuel consumption, mpg/ltr per 100 km ⁽⁰⁶⁾		
	Urban	29.7/9.5	
	Extra-urban	47.9/5.9	
	Combined	39.2/7.2	
	Official CO ₂ emission, g/km ⁽⁰⁷⁾	169	
	Emission class	EURO 4	
Noise, dB	73.0		

Notes.

- 01) The maximum power output figures are quoted in PS (or Pferdestärke, which is the metric equivalent of horsepower). To convert from metric to imperial horsepower, divide the PS figure by 1.0139.
- 02) Figures are calculated in accordance with manufacturer's criteria. Vehicle unladen weight ranges with 90% tank capacity without driver. The individual unladen weight depends on the specification of the vehicle, this then reduces the possible payload accordingly.
- 03) With increasing altitude the engine performance diminishes. From 1,000 m above sea level and for every 1,000 m thereafter 10% of the vehicle/trailer weight (trailer weight + gross vehicle weight) must be deducted.
- 04) Thanks to the knock control, unleaded four star (at least 95 RON) can be used instead of unleaded Super plus. In order to achieve maximum fuel consumption benefits on the FSI engine, Ultra Low Sulphur Petrol (ULSP) must be used.
- 05) The use of RME and FAME (bio diesel) is not possible.
- 06) Official fuel consumption according to EU Directive 99/94. The consumption calculation according to 1999/100/EC is based on the actual unladen weight of the vehicle. Additional specifications can lead to a higher weight class and hence to consumption figures of this higher weight class. The driving style, road and traffic conditions, environmental influences and vehicle condition can in practice lead to consumption figures, which may differ from those calculated with this standard.
- 07) The weight of a vehicle will influence the level of CO₂ emission it produces; as a result, vehicles with higher levels of specification and factory-fitted options may emit higher levels of CO₂. The CO₂ figure quoted for each vehicle is the maximum possible. The unladen weight of the vehicle is calculated by range at the time of manufacture and the maximum possible CO₂ emission for that weight range is applied according to the Council Directive 80/1268EEC as amended by Commission Directive 1999/100/EC on the approximation of the laws of the member states relating to the carbon dioxide emissions and the fuel consumption of motor vehicles.

GT – 1.4 litre TSI 170 PS.

Technical specification.

		Manual	Automatic DSG
Engine	Engine type	Four cylinder petrol	Four cylinder petrol
	Cubic capacity, ltrs/cc	1.4/1390	1.4/1390
	Bore/stroke, mm	76.5/75.6	76.5/75.6
	Max. output, PS ⁽⁰¹⁾ /kW at rpm	170/125 6000	170/125 6000
	Max. torque, lbs.ft/Nm at rpm	177/240 1750	177/240 1750
	Compression ratio	10.0 : 1	10.0 : 1
	Gearbox	Six speed manual	Six speed auto DSG
	Alternator, A	110	110
	Battery, A (Ah)	220 (44)	220 (44)
Weights, kgs	Unladen weight ⁽⁰²⁾	1429	1451
	Gross vehicle weight	1850	1870
	Payload ⁽⁰²⁾	421	419
	Axle load limit: Front Rear	1020 900	1030 910
Trailer load limits, kgs⁽⁰³⁾	Braked 12% incline	1400	TBA
	Unbraked	650	TBA
Performance	Top speed (where law permits), mph (km/h)	137 (220)	TBA
	Acceleration, secs 0 - 62 mph	7.9	TBA
	ABI insurance group	16	16
Environmental information	Fuel grade, minimum	Unleaded, 95 RON ⁽⁰⁴⁾	Unleaded, 95 RON ⁽⁰⁴⁾
	Fuel tank capacity, galls/ltrs	12.1/55	12.1/55
	Official fuel consumption, mpg/ltr per 100 km ⁽⁰⁶⁾		
	Urban	28.8/9.8	28.2/10.0
	Extra-urban	46.3/6.1	47.9/5.9
	Combined	38.2/7.4	38.2/7.4
	Official CO ₂ emission, g/km ⁽⁰⁷⁾	175	175
	Emission class	EURO 4	EURO 4
Noise, dB	74.0	TBA	

Notes.

- 01) The maximum power output figures are quoted in PS (or Pferdestärke, which is the metric equivalent of horsepower). To convert from metric to imperial horsepower, divide the PS figure by 1.0139.
- 02) Figures are calculated in accordance with manufacturer's criteria. Vehicle unladen weight ranges with 90% tank capacity without driver. The individual unladen weight depends on the specification of the vehicle, this then reduces the possible payload accordingly.
- 03) With increasing altitude the engine performance diminishes. From 1,000 m above sea level and for every 1,000 m thereafter 10% of the vehicle/trailer weight (trailer weight + gross vehicle weight) must be deducted.
- 04) Thanks to the knock control, unleaded four star (at least 95 RON) can be used instead of unleaded Super plus. In order to achieve maximum fuel consumption benefits on the FSI engine, Ultra Low Sulphur Petrol (ULSP) must be used.
- 05) The use of RME and FAME (bio diesel) is not possible.
- 06) Official fuel consumption according to EU Directive 99/94. The consumption calculation according to 1999/100/EC is based on the actual unladen weight of the vehicle. Additional specifications can lead to a higher weight class and hence to consumption figures of this higher weight class. The driving style, road and traffic conditions, environmental influences and vehicle condition can in practice lead to consumption figures, which may differ from those calculated with this standard.
- 07) The weight of a vehicle will influence the level of CO₂ emission it produces; as a result, vehicles with higher levels of specification and factory-fitted options may emit higher levels of CO₂. The CO₂ figure quoted for each vehicle is the maximum possible. The unladen weight of the vehicle is calculated by range at the time of manufacture and the maximum possible CO₂ emission for that weight range is applied according to the Council Directive 80/1268EEC as amended by Commission Directive 1999/100/EC on the approximation of the laws of the member states relating to the carbon dioxide emissions and the fuel consumption of motor vehicles.

GTI – 2.0 litre T-FSI 200 PS.

Technical specification.

		Manual	Automatic DSG
Engine	Engine type	Four cylinder petrol	Four cylinder petrol
	Cubic capacity, ltrs/cc	2.0/1984	2.0/1984
	Bore/stroke, mm	82.5/92.8	82.5/92.8
	Max. output, PS ⁽⁰¹⁾ /kW at rpm	200/147 5000	200/147 5000
	Max. torque, lbs.ft/Nm at rpm	207/280 1800	207/280 1800
	Compression ratio	10.5 : 1	10.5 : 1
	Gearbox	Six speed manual	Six speed auto DSG
	Alternator, A	140	140
	Battery, A (Ah)	380 (72)	380 (72)
Weights, kgs	Unladen weight ⁽⁰²⁾	1336	1355
	Gross vehicle weight	1860	1880
	Payload ⁽⁰²⁾	524	525
	Axle load limit: Front Rear	1030 900	1050 900
Trailer load limits, kgs⁽⁰³⁾	Braked 12% incline	1400	1400
	Unbraked	700	710
Performance	Top speed (where law permits), mph (km/h)	146 (235)	145 (233)
	Acceleration, secs 0 - 62 mph	7.2	6.9
	ABI insurance group	17	17
Environmental information	Fuel grade, minimum	Unleaded, 95 RON ⁽⁰⁴⁾	Unleaded, 95 RON ⁽⁰⁴⁾
	Fuel tank capacity, galls/ltrs	12.1/55	12.1/55
	Official fuel consumption, mpg/ltr per 100 km ⁽⁰⁶⁾		
	Urban	25.4/11.1	26.2/10.8
	Extra-urban	44.8/6.3	44.8/6.3
	Combined	34.9/8.1	35.3/8.0
	Official CO ₂ emission, g/km ⁽⁰⁷⁾	194	192
	Emission class	EURO 4	EURO 4
Noise, dB	75.0	74.0	

Notes.

- 01) The maximum power output figures are quoted in PS (or Pferdestärke, which is the metric equivalent of horsepower). To convert from metric to imperial horsepower, divide the PS figure by 1.0139.
- 02) Figures are calculated in accordance with manufacturer's criteria. Vehicle unladen weight ranges with 90% tank capacity without driver. The individual unladen weight depends on the specification of the vehicle, this then reduces the possible payload accordingly.
- 03) With increasing altitude the engine performance diminishes. From 1,000 m above sea level and for every 1,000 m thereafter 10% of the vehicle/trailer weight (trailer weight + gross vehicle weight) must be deducted.
- 04) Thanks to the knock control, unleaded four star (at least 95 RON) can be used instead of unleaded Super plus. In order to achieve maximum fuel consumption benefits on the FSI engine, Ultra Low Sulphur Petrol (ULSP) must be used.
- 05) The use of RME and FAME (bio diesel) is not possible.
- 06) Official fuel consumption according to EU Directive 99/94. The consumption calculation according to 1999/100/EC is based on the actual unladen weight of the vehicle. Additional specifications can lead to a higher weight class and hence to consumption figures of this higher weight class. The driving style, road and traffic conditions, environmental influences and vehicle condition can in practice lead to consumption figures, which may differ from those calculated with this standard.
- 07) The weight of a vehicle will influence the level of CO₂ emission it produces; as a result, vehicles with higher levels of specification and factory-fitted options may emit higher levels of CO₂. The CO₂ figure quoted for each vehicle is the maximum possible. The unladen weight of the vehicle is calculated by range at the time of manufacture and the maximum possible CO₂ emission for that weight range is applied according to the Council Directive 80/1268EEC as amended by Commission Directive 1999/100/EC on the approximation of the laws of the member states relating to the carbon dioxide emissions and the fuel consumption of motor vehicles.

R32 4MOTION – 3.2 litre V6 250 PS.

Technical specification.

		Manual 4MOTION	Automatic DSG 4MOTION
Engine	Engine type	Six cylinder petrol	Six cylinder petrol
	Cubic capacity, ltrs/cc	3.2/3189	3.2/3189
	Bore/stroke, mm	84.0/95.9	84.0/95.9
	Max. output, PS ⁽⁰¹⁾ /kW at rpm	250/184 6300	250/184 6300
	Max. torque, lbs.ft/Nm at rpm	236/320 2800	236/320 2800
	Compression ratio	10.9 : 1	10.9 : 1
	Gearbox	Six speed manual	Six speed auto DSG
	Alternator, A	140	140
	Battery, A (Ah)	420 (75)	420 (75)
Weights, kgs	Unladen weight ⁽⁰²⁾	1590	1617
	Gross vehicle weight	2050	2070
	Payload ⁽⁰²⁾	460	453
	Axle load limit: Front Rear	1080 1020	1100 1020
Trailer load limits, kgs⁽⁰³⁾	Braked 12% incline	–	–
	Unbraked	–	–
Performance	Top speed (where law permits), mph (km/h)	155 (250)	154 (248)
	Acceleration, secs 0 - 62 mph	6.5	6.2
	ABI insurance group	18	18
Environmental information	Fuel grade, minimum	Unleaded, 95 RON ⁽⁰⁴⁾	Unleaded, 95 RON ⁽⁰⁴⁾
	Fuel tank capacity, galls/ltrs	12.1/55	12.1/55
	Official fuel consumption, mpg/ltr per 100 km ⁽⁰⁶⁾		
	Urban	18.8/15.0	21.4/13.2
	Extra-urban	33.6/8.4	36.2/7.8
	Combined	26.2/10.8	28.8/9.8
	Official CO ₂ emission, g/km ⁽⁰⁷⁾	259	235
	Emission class	EURO 4	EURO 4
Noise, dB	75.0	73.0	

Notes.

- 01) The maximum power output figures are quoted in PS (or Pferdestärke, which is the metric equivalent of horsepower). To convert from metric to imperial horsepower, divide the PS figure by 1.0139.
- 02) Figures are calculated in accordance with manufacturer's criteria. Vehicle unladen weight ranges with 90% tank capacity without driver. The individual unladen weight depends on the specification of the vehicle, this then reduces the possible payload accordingly.
- 03) With increasing altitude the engine performance diminishes. From 1,000 m above sea level and for every 1,000 m thereafter 10% of the vehicle/trailer weight (trailer weight + gross vehicle weight) must be deducted.
- 04) Thanks to the knock control, unleaded four star (at least 95 RON) can be used instead of unleaded Super plus. In order to achieve maximum fuel consumption benefits on the FSI engine, Ultra Low Sulphur Petrol (ULSP) must be used.
- 05) The use of RME and FAME (bio diesel) is not possible.
- 06) Official fuel consumption according to EU Directive 99/94. The consumption calculation according to 1999/100/EC is based on the actual unladen weight of the vehicle. Additional specifications can lead to a higher weight class and hence to consumption figures of this higher weight class. The driving style, road and traffic conditions, environmental influences and vehicle condition can in practice lead to consumption figures, which may differ from those calculated with this standard.
- 07) The weight of a vehicle will influence the level of CO₂ emission it produces; as a result, vehicles with higher levels of specification and factory-fitted options may emit higher levels of CO₂. The CO₂ figure quoted for each vehicle is the maximum possible. The unladen weight of the vehicle is calculated by range at the time of manufacture and the maximum possible CO₂ emission for that weight range is applied according to the Council Directive 80/1268EEC as amended by Commission Directive 1999/100/EC on the approximation of the laws of the member states relating to the carbon dioxide emissions and the fuel consumption of motor vehicles.

S – 2.0 litre SDI 75 PS.

Technical specification.

		Manual	
Engine	Engine type	Four cylinder diesel	
	Cubic capacity, ltrs/cc	2.0/1968	
	Bore/stroke, mm	81.0/95.5	
	Max. output, PS ⁽⁰¹⁾ /kW at rpm	75/55 4200	
	Max. torque, lbs.ft/Nm at rpm	103/140 2200	
	Compression ratio	19.0 : 1	
	Gearbox	Five speed manual	
	Alternator, A	140	
	Battery, A (Ah)	340 (70)	
Weights, kgs	Unladen weight ⁽⁰²⁾	1427	
	Gross vehicle weight	1790	
	Payload ⁽⁰²⁾	403	
	Axle load limit: Front Rear	990 870	
Trailer load limits, kgs ⁽⁰³⁾	Braked 12% incline	1000	
	Unbraked	610	
Performance	Top speed (where law permits), mph (km/h)	101 (163)	
	Acceleration, secs 0 - 62 mph	16.7	
	ABI insurance group	6	
Environmental information	Fuel grade, minimum	Diesel ⁽⁰⁵⁾	
	Fuel tank capacity, galls/ltrs	12.1/55	
	Official fuel consumption, mpg/ltr per 100 km ⁽⁰⁶⁾		
	Urban	41.5/6.8	
	Extra-urban	60.1/4.7	
	Combined	52.3/5.4	
	Official CO ₂ emission, g/km ⁽⁰⁷⁾	146	
Emission class	EURO 4		
Noise, dB	73.0		

Notes.

- 01) The maximum power output figures are quoted in PS (or Pferdestärke, which is the metric equivalent of horsepower). To convert from metric to imperial horsepower, divide the PS figure by 1.0139.
- 02) Figures are calculated in accordance with manufacturer's criteria. Vehicle unladen weight ranges with 90% tank capacity without driver. The individual unladen weight depends on the specification of the vehicle, this then reduces the possible payload accordingly.
- 03) With increasing altitude the engine performance diminishes. From 1,000 m above sea level and for every 1,000 m thereafter 10% of the vehicle/trailer weight (trailer weight + gross vehicle weight) must be deducted.
- 04) Thanks to the knock control, unleaded four star (at least 95 RON) can be used instead of unleaded Super plus. In order to achieve maximum fuel consumption benefits on the FSI engine, Ultra Low Sulphur Petrol (ULSP) must be used.
- 05) The use of RME and FAME (bio diesel) is not possible.
- 06) Official fuel consumption according to EU Directive 99/94. The consumption calculation according to 1999/100/EC is based on the actual unladen weight of the vehicle. Additional specifications can lead to a higher weight class and hence to consumption figures of this higher weight class. The driving style, road and traffic conditions, environmental influences and vehicle condition can in practice lead to consumption figures, which may differ from those calculated with this standard.
- 07) The weight of a vehicle will influence the level of CO₂ emission it produces; as a result, vehicles with higher levels of specification and factory-fitted options may emit higher levels of CO₂. The CO₂ figure quoted for each vehicle is the maximum possible. The unladen weight of the vehicle is calculated by range at the time of manufacture and the maximum possible CO₂ emission for that weight range is applied according to the Council Directive 80/1268EEC as amended by Commission Directive 1999/100/EC on the approximation of the laws of the member states relating to the carbon dioxide emissions and the fuel consumption of motor vehicles.

S, SE, Sport – 1.9 litre TDI 105 PS.

Technical specification.

		Five speed manual – S, SE	Six speed manual – Sport	Automatic DSG – SE
Engine	Engine type	Four cylinder diesel	Four cylinder diesel	Four cylinder diesel
	Cubic capacity, ltrs/cc	1.9/1896	1.9/1896	1.9/1896
	Bore/stroke, mm	79.5/95.5	79.5/95.5	79.5/95.5
	Max. output, PS ⁽⁰¹⁾ /kW at rpm	105/77 4000	105/77 4000	105/77 4000
	Max. torque, lbs.ft/Nm at rpm	184/250 1900	184/250 1900	184/250 1900
	Compression ratio	19.0 : 1	19.0 : 1	19.0 : 1
	Gearbox	Five speed manual	Six speed manual	Six speed auto DSG
	Alternator, A	140	140	140
	Battery, A (Ah)	340 (70)	340 (70)	340 (70)
Weights, kgs	Unladen weight ⁽⁰²⁾	1425	1425	1471
	Gross vehicle weight	1850	1850	1880
	Payload ⁽⁰²⁾	425	425	409
	Axle load limit: Front Rear	1050 870	1050 870	1080 870
Trailer load limits, kgs⁽⁰³⁾	Braked 12% incline	1400	1400	1400
	Unbraked	660	660	680
Performance	Top speed (where law permits), mph (km/h)	116 (187)	116 (187)	115 (185)
	Acceleration, secs 0 - 62 mph	11.3	11.1	11.2
	ABI insurance group	6	6	6
Environmental information	Fuel grade, minimum	Diesel ⁽⁰⁵⁾	Diesel ⁽⁰⁵⁾	Diesel ⁽⁰⁵⁾
	Fuel tank capacity, galls/ltrs	12.1/55	12.1/55	12.1/55
	Official fuel consumption, mpg/ltr per 100 km ⁽⁰⁶⁾			
	Urban	42.2/6.7	40.4/7.0	37.7/7.5
	Extra-urban	61.4/4.6	60.1/4.7	58.9/4.8
	Combined	53.3/5.3	51.4/5.5	48.7/5.8
	Official CO ₂ emission, g/km ⁽⁰⁷⁾	143	149	157
	Emission class	EURO 4	EURO 4	EURO 4
Noise, dB	73.0	71.0	69.0	

Notes.

- 01) The maximum power output figures are quoted in PS (or Pferdestärke, which is the metric equivalent of horsepower). To convert from metric to imperial horsepower, divide the PS figure by 1.0139.
- 02) Figures are calculated in accordance with manufacturer's criteria. Vehicle unladen weight ranges with 90% tank capacity without driver. The individual unladen weight depends on the specification of the vehicle, this then reduces the possible payload accordingly.
- 03) With increasing altitude the engine performance diminishes. From 1,000 m above sea level and for every 1,000 m thereafter 10% of the vehicle/trailer weight (trailer weight + gross vehicle weight) must be deducted.
- 04) Thanks to the knock control, unleaded four star (at least 95 RON) can be used instead of unleaded Super plus. In order to achieve maximum fuel consumption benefits on the FSI engine, Ultra Low Sulphur Petrol (ULSP) must be used.
- 05) The use of RME and FAME (bio diesel) is not possible.
- 06) Official fuel consumption according to EU Directive 99/94. The consumption calculation according to 1999/100/EC is based on the actual unladen weight of the vehicle. Additional specifications can lead to a higher weight class and hence to consumption figures of this higher weight class. The driving style, road and traffic conditions, environmental influences and vehicle condition can in practice lead to consumption figures, which may differ from those calculated with this standard.
- 07) The weight of a vehicle will influence the level of CO₂ emission it produces; as a result, vehicles with higher levels of specification and factory-fitted options may emit higher levels of CO₂. The CO₂ figure quoted for each vehicle is the maximum possible. The unladen weight of the vehicle is calculated by range at the time of manufacture and the maximum possible CO₂ emission for that weight range is applied according to the Council Directive 80/1268EEC as amended by Commission Directive 1999/100/EC on the approximation of the laws of the member states relating to the carbon dioxide emissions and the fuel consumption of motor vehicles.

Sport, GT TDI, Sport TDI 4MOTION – 2.0 litre TDI 140 PS.

Technical specification.

		Manual	Automatic DSG	Manual 4MOTION
Engine	Engine type	Four cylinder diesel	Four cylinder diesel	Four cylinder diesel
	Cubic capacity, ltrs/cc	2.0/1968	2.0/1968	2.0/1968
	Bore/stroke, mm	81.0/95.5	81.0/95.5	81.0/95.5
	Max. output, PS ⁽⁰¹⁾ /kW at rpm	140/103 4000	140/103 4000	140/103 4000
	Max. torque, lbs.ft/Nm at rpm	236/320 1750	236/320 1750	236/320 1750
	Compression ratio	18.5 : 1	18.5 : 1	18.5 : 1
	Gearbox	Six speed manual	Six speed auto DSG	Six speed manual
	Alternator, A	140	140	140
	Battery, A (Ah)	340 (70)	340 (70)	340 (70)
Weights, kgs	Unladen weight ⁽⁰²⁾	1451	1486	1576
	Gross vehicle weight	1870	1900	1980
	Payload ⁽⁰²⁾	419	414	404
	Axle load limit: Front	1070	1100	1100
	Rear	870	870	950
Trailer load limits, kgs⁽⁰³⁾	Braked 12% incline	1400	1400	1600
	Unbraked	670	690	740
Performance	Top speed (where law permits), mph (km/h)	127 (205)	126 (203)	126 (203)
	Acceleration, secs 0 - 62 mph	9.3	9.3	9.5
	ABI insurance group	13	13	13
Environmental information	Fuel grade, minimum	Diesel ⁽⁰⁵⁾	Diesel ⁽⁰⁵⁾	Diesel ⁽⁰⁵⁾
	Fuel tank capacity, galls/ltrs	12.1/55	12.1/55	13.2/60
	Official fuel consumption, mpg/ltr per 100 km ⁽⁰⁶⁾			
	Urban	39.8/7.1	35.3/8.0	36.2/7.8
	Extra-urban	58.9/4.8	56.5/5.0	55.4/5.1
	Combined	49.6/5.7	46.3/6.1	47.1/6.0
	Official CO ₂ emission, g/km ⁽⁰⁷⁾	154	160	160
	Emission class	EURO 4	EURO 4	EURO 4
Noise, dB	72.0	71.0	72.0	

Notes.

- 01) The maximum power output figures are quoted in PS (or Pferdestärke, which is the metric equivalent of horsepower). To convert from metric to imperial horsepower, divide the PS figure by 1.0139.
- 02) Figures are calculated in accordance with manufacturer's criteria. Vehicle unladen weight ranges with 90% tank capacity without driver. The individual unladen weight depends on the specification of the vehicle, this then reduces the possible payload accordingly.
- 03) With increasing altitude the engine performance diminishes. From 1,000 m above sea level and for every 1,000 m thereafter 10% of the vehicle/trailer weight (trailer weight + gross vehicle weight) must be deducted.
- 04) Thanks to the knock control, unleaded four star (at least 95 RON) can be used instead of unleaded Super plus. In order to achieve maximum fuel consumption benefits on the FSI engine, Ultra Low Sulphur Petrol (ULSP) must be used.
- 05) The use of RME and FAME (bio diesel) is not possible.
- 06) Official fuel consumption according to EU Directive 99/94. The consumption calculation according to 1999/100/EC is based on the actual unladen weight of the vehicle. Additional specifications can lead to a higher weight class and hence to consumption figures of this higher weight class. The driving style, road and traffic conditions, environmental influences and vehicle condition can in practice lead to consumption figures, which may differ from those calculated with this standard.
- 07) The weight of a vehicle will influence the level of CO₂ emission it produces; as a result, vehicles with higher levels of specification and factory-fitted options may emit higher levels of CO₂. The CO₂ figure quoted for each vehicle is the maximum possible. The unladen weight of the vehicle is calculated by range at the time of manufacture and the maximum possible CO₂ emission for that weight range is applied according to the Council Directive 80/1268EEC as amended by Commission Directive 1999/100/EC on the approximation of the laws of the member states relating to the carbon dioxide emissions and the fuel consumption of motor vehicles.

GT TDI – 2.0 litre TDI DPF 170 PS.

Technical specification.

		Manual	Automatic DSG	
Engine	Engine type	Four cylinder diesel	Four cylinder diesel	
	Cubic capacity, ltrs/cc	2.0/1968	2.0/1968	
	Bore/stroke, mm	81.0/95.5	81.0/95.5	
	Max. output, PS ⁽⁰¹⁾ /kW at rpm	170/125 4200	170/125 4200	
	Max. torque, lbs.ft/Nm at rpm	258/350 1750	258/350 1750	
	Compression ratio	18.5 : 1	18.5 : 1	
	Gearbox	Six speed manual	Six speed auto DSG	
	Alternator, A	140	TBA	
	Battery, A (Ah)	330 (61)	TBA	
Weights, kgs	Unladen weight ⁽⁰²⁾	1445	1480	
	Gross vehicle weight	1870	1900	
	Payload ⁽⁰²⁾	425	420	
	Axle load limit: Front Rear	1060 880	1090 880	
Trailer load limits, kgs ⁽⁰³⁾	Braked 12% incline	1500	1500	
	Unbraked	680	700	
Performance	Top speed (where law permits), mph (km/h)	137 (220)	135 (217)	
	Acceleration, secs 0 - 62 mph	8.2	8.2	
	ABI insurance group	16	16	
Environmental information	Fuel grade, minimum	Diesel ⁽⁰⁵⁾	Diesel ⁽⁰⁵⁾	
	Fuel tank capacity, galls/ltrs	12.1/55	12.1/55	
	Official fuel consumption, mpg/ltr per 100 km ⁽⁰⁶⁾			
	Urban	35.8/7.9	34.4/8.2	
	Extra-urban	56.5/5.0	51.4/5.5	
	Combined	46.3/6.1	43.5/6.5	
	Official CO ₂ emission, g/km ⁽⁰⁷⁾	160	176	
	Emission class	EURO 4	EURO 4	
Noise, dB	73.0	71.0		

Notes.

- 01) The maximum power output figures are quoted in PS (or Pferdestärke, which is the metric equivalent of horsepower). To convert from metric to imperial horsepower, divide the PS figure by 1.0139.
- 02) Figures are calculated in accordance with manufacturer's criteria. Vehicle unladen weight ranges with 90% tank capacity without driver. The individual unladen weight depends on the specification of the vehicle, this then reduces the possible payload accordingly.
- 03) With increasing altitude the engine performance diminishes. From 1,000 m above sea level and for every 1,000 m thereafter 10% of the vehicle/trailer weight (trailer weight + gross vehicle weight) must be deducted.
- 04) Thanks to the knock control, unleaded four star (at least 95 RON) can be used instead of unleaded Super plus. In order to achieve maximum fuel consumption benefits on the FSI engine, Ultra Low Sulphur Petrol (ULSP) must be used.
- 05) The use of RME and FAME (bio diesel) is not possible.
- 06) Official fuel consumption according to EU Directive 99/94. The consumption calculation according to 1999/100/EC is based on the actual unladen weight of the vehicle. Additional specifications can lead to a higher weight class and hence to consumption figures of this higher weight class. The driving style, road and traffic conditions, environmental influences and vehicle condition can in practice lead to consumption figures, which may differ from those calculated with this standard.
- 07) The weight of a vehicle will influence the level of CO₂ emission it produces; as a result, vehicles with higher levels of specification and factory-fitted options may emit higher levels of CO₂. The CO₂ figure quoted for each vehicle is the maximum possible. The unladen weight of the vehicle is calculated by range at the time of manufacture and the maximum possible CO₂ emission for that weight range is applied according to the Council Directive 80/1268EEC as amended by Commission Directive 1999/100/EC on the approximation of the laws of the member states relating to the carbon dioxide emissions and the fuel consumption of motor vehicles.

The technology.

Transmission

- Front wheel drive through asbestos-free single-plate dry clutch. Hydraulic clutch-mechanism. Five/six speed manual gearbox with double joint half axles
- Four wheel drive (4MOTION only) with electronically controlled multi-plate clutch. Electronic differential lock, combined with a hydraulically operated single-plate dry clutch with asbestos-free lining via a six speed manual gearbox
- Five speed manual: 1.4 litre 80 PS, 2.0 litre 75 PS SDI, 1.9 litre 105 PS TDI
- Six speed manual: 1.4 litre 140 PS TSI, 1.4 litre 170 PS TSI, 1.6 litre 115 PS FSI, 2.0 litre 200 PS T-FSI, 3.2 litre 250 PS, 1.9 litre 105 PS TDI – Sport only, 2.0 litre 140 PS TDI, 2.0 litre 170 PS TDI DPF
- Six speed automatic: 1.6 litre 115 PS FSI
- Six speed automatic DSG: 1.4 litre 170 PS TSI, 2.0 litre 200 PS T-FSI, 3.2 litre 250 PS, 1.9 litre 105 PS TDI, 2.0 litre 140 PS TDI, 2.0 litre 170 PS TDI DPF

Steering

- Electro-mechanical steering rack, height and lengthways adjustable
- Collapsible safety steering column

Running gear

- Electronic Stabilisation Programme (ESP) including Electronic Differential Lock (EDL) and Traction Control (ASR)
- Front suspension through coil springs with telescopic shock absorbers, all elements integrated in chassis legs
- Rear suspension with gas pressure shock absorbers and separate springs
- Wheel control: front through chassis legs and (lower) triangular wishbones (directionally stabilising steering roll radius)
- Wheel control: rear through four-link suspension with independent wheel suspension
- Front and rear anti-roll bar

Brakes

- Electronically controlled Anti-lock Braking System (ABS) with Electronic Brake-pressure Distribution (EBD)
- Diagonal twin-circuit brake system with inner-ventilated front disc brakes and rear disc brakes
- Asbestos-free brake pads

Engines

- Front transverse-installed engine
- 1.4 litre/80 PS¹ (59 kW) petrol engine: TBA
- 1.6 litre/115 PS¹ (85 kW) petrol engine: four cylinder in-line engine, aluminium cylinder head, four valves per cylinder with roller valve lever drive, electronic direct injection (FSI), programmed ignition with cylinder-selective anti-knock control, four single spark ignition coils, longlife spark plugs, exhaust gas recirculation, three-way front catalyst, NOx storage catalyst
- 1.4 litre/140 PS¹ (103 kW) petrol engine: TBA
- 1.4 litre/170 PS¹ (125 kW) petrol engine: TBA
- 2.0 litre/200 PS¹ (147 kW) petrol engine: four cylinder in-line engine, aluminium cylinder head, four valves per cylinder with roller rocker finger valve drive, electronic direct injection (T-FSI), variable inlet valve timing, programmed ignition with cylinder-selective anti-knock control, four single spark ignition coils, longlife spark plugs, exhaust gas turbocharger, three-way close-coupled pre-catalyst and underbody catalyst, lambda control
- 3.2 litre/250 PS¹ (184 kW) petrol engine: six cylinder transverse engine in 'V' format, aluminium cylinder head, four valves per cylinder with roller rocker valve lever drive, electronic indirect injection, distributorless electronic ignition, three-way catalyst, lambda control
- 2.0 litre/75 PS¹ (55 kW) diesel engine: four cylinder in-line engine, two valves per cylinder, electronically controlled direct injection, oxidation catalyst
- 1.9 litre/105 PS¹ (77 kW) diesel engine: four cylinder in-line engine, two valves per cylinder, electronically controlled direct injection, oxidation catalyst
- 2.0 litre/140 PS¹ (103 kW) diesel engine: four cylinder in-line engine, four valves per cylinder, electronically controlled direct injection with pump injector unit, oil cooler, intercooler, exhaust gas recirculation, oxidation catalyst, turbocharger with variable turbine geometry
- 2.0 litre/170 PS¹ (125 kW) diesel engine: TBA

¹ The maximum power output figures are quoted in PS (or Pferdestärke, which is the metric equivalent of horsepower). To convert from metric to imperial horsepower, divide the PS figure by 1.0139.

Dimensions.

Maximum luggage capacity, cu.ft (litres) VDA measuring method using 200 x 100 x 50 mm blocks	S, SE, Sport, GT, GTI		Sport TDI 4MOTION, R32
	With rear seat upright*	12.4 (350)	9.7 (275)
With rear seat folded*	46.1 (1305)	43.4 (1230)	

* With standard steel space saver spare wheel.

Exterior dimensions	S, SE, Sport, GT, Sport TDI 4MOTION		GTI	R32
	Length, mm	4204	4216	(4246)
Width – excluding door mirrors, mm	1759	1759	(1759)	
Width – opened front doors – 3 door/5 door, mm	4050/3630	4050/3630	(4050/3630)	
Height, mm	1479	1469	(1465)	
Height – opened bonnet/floor, mm	1764	1756	(1752)	
Height – opened tailgate/floor, mm	2055	2044	(2040)	
Wheelbase, mm	2578	2578	(2578)	

Exterior dimensions S, SE, Sport, GT, Sport TDI 4MOTION

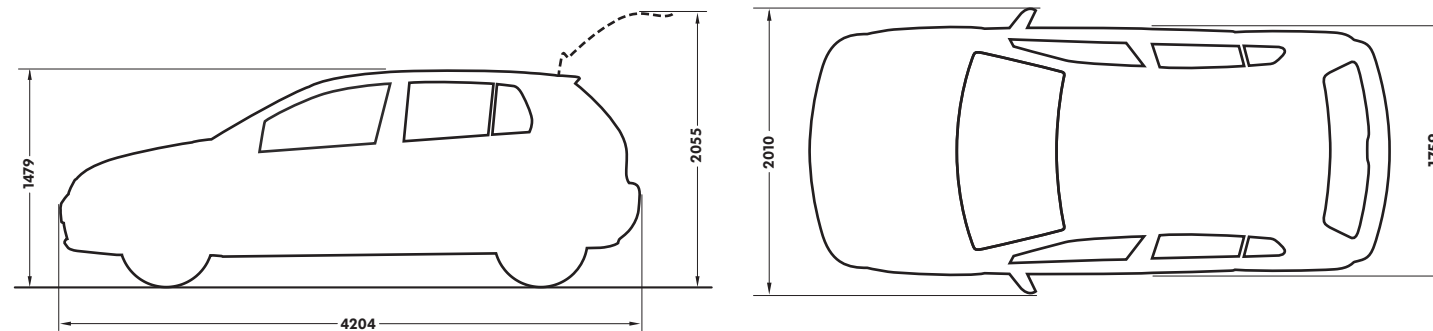

Exterior dimensions GTI, R32

() Golf R32 figures.

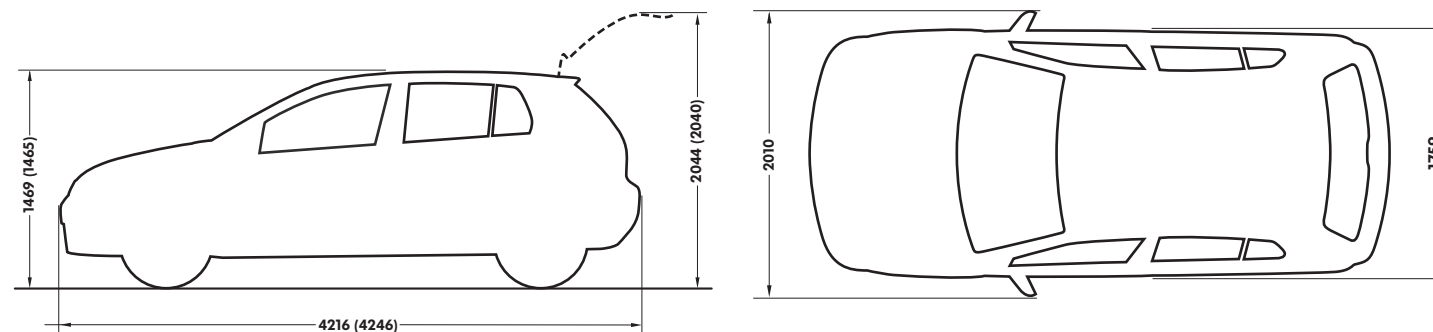

Volkswagen service for your peace of mind.

The Volkswagen Warranty.

Three-year Warranty.

All Volkswagen Golfs come with a three-year/60,000 miles warranty, which protects your car against the failure of most mechanical and electrical components due to manufacturing defects. This comprises a two-year manufacturer's warranty with unlimited mileage plus a further one-year/60,000 miles (whichever is soonest) Retailer Warranty. Should the mileage exceed 60,000 miles within the first two years, the manufacturer's two-year warranty will still be valid. If an additional warranty for subsequent years or higher mileage is desired, it may be purchased from an authorised Volkswagen retailer or repairer; however, this additional warranty must be purchased before the mileage reaches 60,000. Full details of the three-year warranty are available from your authorised Volkswagen retailer or repairer.

Three-year Paint Warranty.

The paintwork of the Golf is covered against manufacturing defects for a period of three years. Naturally, the Golf must be cared for in compliance with the operating instructions which will be found in your vehicle handbook. Please consult your authorised Volkswagen retailer or repairer for full warranty details.

12-year Body Protection Warranty.

The internal body sections and panels of the Golfs are covered against rusting through from the inside for 12 years. Naturally, the Golf must be cared for in compliance with the operating instructions. Please consult your authorised Volkswagen retailer or repairer for full warranty details.

Service Intervals.

Volkswagen are pleased to offer you a choice on how your Golf is serviced. The appropriate selection is entirely dependent on how the car is likely to be driven and its general use. To help you identify which type of service would be most suitable, please refer to the following guide.

The Time and Distance Service is recommended for vehicles that will cover less than 10,000 miles in 12 months and if the vehicle is likely to be used in the following way:

- Predominantly urban driving, short journeys with frequent cold starts.
- Activities regularly producing high engine loading, e.g. frequent hill climbs, driving with vehicle fully loaded and towing.
- Uneconomical driving style using high rpms with heavy acceleration and heavy braking.

The service intervals for the Time and Distance Service are as follows:

- Oil change service
Every 10,000 miles/1 year (whichever is soonest).
- Interval service
Every 20,000 miles/2 years (whichever is soonest).
- Interval service inspection
Every 40,000 miles/4 years (whichever is soonest).

The LongLife Service is recommended for vehicles with a daily mileage of more than 25 miles where the vehicle is driven regularly mainly on longer distance journeys. The vehicle is driven mainly at a constant speed with minimum vehicle and engine loading, minimal towing and driven in an economical manner.

With the LongLife Service the vehicle can cover anywhere between 10,000* and a maximum of 20,000* miles or 24 months (whichever is soonest).

* Please note that mileages are approximate as the service indicator system uses kilometres as the distance measurement. Please consult your authorised Volkswagen retailer or repairer for advice and full details.

Approved Accessories.

A comprehensive range of accessories from alloy wheels to carpet mats is available to complement the factory-fitted option list. Volkswagen approved accessories purchased from and fitted by your authorised Volkswagen retailer at the point of vehicle sale will also benefit from the three-year vehicle warranty.

Volkswagen Insurance.

Competitive insurance premiums are available to Volkswagen owners through Volkswagen Insurance Service (Great Britain) Limited. Volkswagen Insurance guarantees that all repair work is undertaken by an authorised Volkswagen retailer or repairer. For a quotation, telephone Linkline on 0845 600 8006.

Extended Warranty.

You may purchase additional protection from your authorised Volkswagen retailer or repairer, or contact 0870 9000 115.

Volkswagen Finance†.

Volkswagen Finance specialises in providing funding solutions for Volkswagen drivers. Whether your Volkswagen is for private or business use, you can choose from a range of funding options.

- Solutions – a personal contract plan
- Hire purchase
- Lease purchase
- Finance lease
- Contract hire

With all Volkswagen Finance products you can choose a fixed-cost maintenance plan to help you budget for your servicing and maintenance costs.

No matter what finance product you choose, your local Volkswagen retailer will be able to provide you with a personalised quote that could meet your budget and vehicle needs.

Volkswagen Assistance.

Every new car is registered for Volkswagen Assistance for one year. This provides vehicle recovery in the unlikely event of a breakdown (subject to conditions). Volkswagen Assistance can also be purchased for subsequent years. For full details, please contact your authorised Volkswagen retailer.

Tax Free Sales.

For full details, please contact your authorised Volkswagen retailer.

CO₂ Emission.

The weight of a vehicle will influence the level of CO₂ emission it produces; as a result, vehicles with higher levels of specification and factory-fitted options may emit higher levels of CO₂.

The CO₂ figure quoted for each vehicle is the maximum possible. The unladen weight of the vehicle is calculated by range at the time of manufacture and the maximum possible CO₂ emission for that weight range is applied according to the Council Directive 80/1268EEC as amended by Commission Directive 1999/100/EC on the approximation of the laws of the member states relating to the carbon dioxide emissions and the fuel consumption of motor vehicles.

Please Note:

Some illustrations in this document do not necessarily reflect UK specifications and may not be available. In particular, controls and some items of equipment are positioned differently for the UK.

The specifications contained in this document are for information purposes only and are subject to change. If you require any specific feature, you must consult your authorised Volkswagen retailer who is regularly updated with any change in specification. Please check model availability and full specification details with your authorised Volkswagen retailer prior to ordering.

Note: We would like to advise you that telephone calls to Volkswagen Customer Care may be monitored and recorded as part of our training and quality assurance processes. All our monitoring and recording processes meet Ofcom regulations.

† Volkswagen Finance is a trading name of Volkswagen Financial Services (UK) Limited. An offer of finance depends on certain conditions. Available to people over 18 in the UK only.