

May 2009



# Chassis and double cabs



## Welcome.

Over the years, we've worked hard to establish Volkswagen Commercial Vehicles as a dependable, well-respected Brand. There is an indefinable robustness that distinguishes both our products and our organisation from others. It's founded in the twin reality of premium quality vehicles on the road, and down-to-earth assistance in our day-to-day dealings with our customers. We want you to have the confidence that wherever you are, whatever business you're in, Volkswagen can be relied on to deliver.

But we're not complacent. We are still working to improve our network of Van Centres, the product range and, of course, the level of customer care. We want to help you find the right vehicle for your business, and the right level of support for you. So if you need assistance, please, just ask.

## Contents.



**02 - 07**  
Welcome to Volkswagen Commercial Vehicles, introduction and importantly your quick reference guide.



**08 - 14**  
The chassis and double cab range – which model is for me?



**15**  
A summary of the chassis and double cab range.



**16 - 27**  
The Volkswagen Transporter chassis and double cabs, standard specifications, prices, factory options and technical data.



**28 - 41**  
The Volkswagen Crafter chassis and double cabs, standard specifications, prices, factory options and technical data.

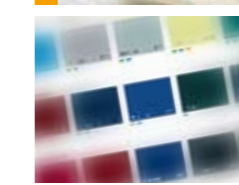

**42 - 43**  
Paint and upholstery for the chassis and double cab range.













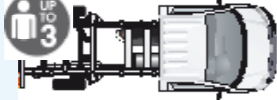

**44 - 51**  
Services, warranties, our dedicated Van Centre network and a useful 'build your vehicle' removable fold out sheet.

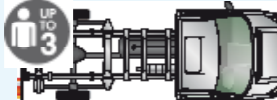

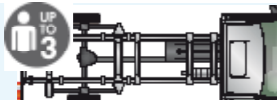
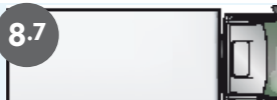
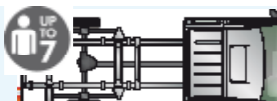
## Introduction.

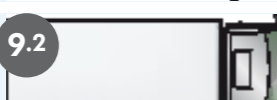

## Chassis and double cab quick reference guide.

Model and price guide*	Occupants	Optional dropside load area m <sup>2</sup>	Unladen weight kg	Payload range kg
<b>Transporter long wheelbase chassis cab</b> £14,830 – £16,750		 5.7	1,740 to 1,815	1,185 to 1,260
<b>Transporter long wheelbase double cab</b> £16,830 – £18,030		 4.2	1,783 to 1,857	1,143 to 1,217
<b>Crafter CR35 medium wheelbase chassis cab</b> £20,490 – £23,790		 6.9	1,755 to 1,757	1,743 to 1,745
<b>Crafter CR35 long wheelbase chassis cab</b> £21,020 – £24,320		 8.7	1,783 to 1,785	1,715 to 1,717
<b>Crafter CR35 long wheelbase double cab</b> £23,580 – £24,480		 6.9	2,059 to 2,061	1,439 to 1,441
<b>Crafter CR50 medium wheelbase chassis cab</b> £26,020 – £27,880		 7.7	1,992 to 1,994	3,006 to 3,008
<b>Crafter CR50 long wheelbase chassis cab</b> £26,550 – £28,410		 9.2	2,030 to 2,032	2,968 to 2,970
<b>Crafter CR50 long wheelbase double cab</b> £28,170 – £29,100		 7.7	2,297 to 2,299	2,701 to 2,703

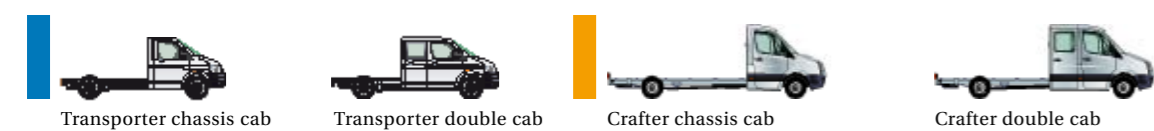

\* Prices exclude VAT, OTR package and optional equipment.



## Introduction.

So you're not thinking about a standard commercial vehicle! And you probably already know whether you want a chassis or double cab. These provide the base vehicles for which you can specify a bespoke conversion (working with one of the Accredited Converters). But there are still a number of questions to be answered in order to get exactly the right vehicle.

What's a factory conversion? What are Accredited Converters? What about servicing, warranties, available accessories and, of course, finance options?

All these, and many other questions, need to be answered before you can make an informed decision. One that's right for your business. And because the Volkswagen Commercial Vehicle range gives you such a wide choice, you're sure to get exactly what you need.

This brochure aims to make that process as easy as possible. We suggest you keep the 'Quick reference guide' and 'Build your vehicle' pages open as you browse to help you in your choice. So let's go to work...

Main image shows Transporter chassis cab with optional dropside body and Crafter double cab with optional dropside body.



## The Volkswagen chassis and double cab range.

What a range this is! For starters, we're the only manufacturer with an automatic gearbox on a diesel engine available across the whole of the range. Not only that, but we have a whole host of engine options, seating options, equipment options and so on. But which one is the right vehicle to choose from such a wide range? After all we can offer both chassis and double cabs and our Accredited Converters have a host of conversion options available.

Dependability is built into the very fabric of the Volkswagen Commercial Vehicles' offering. So is quality, even with our Accredited Converters. So you don't have to worry about it – you can be absolutely certain that whichever model you finally choose, it'll do the job, day in, day out.

So here are a few of the benefits that come as standard:

- UK-wide Van Centre network support
- Finance options tailored to suit your business
- Load and passenger-carrying bodybuilding options
- Value-for-money parts
- LongLife servicing
- Free 3 year Volkswagen Roadside Assistance
- Wide range of accessories for all models
- Accredited Converters warranties.



Safety is a priority.



Your safety is such a vital factor that it is built-in, both with the integral construction of the vehicles, and in the features we include to protect the occupants. A long list of safety and security features applies to every vehicle, but may vary according to model specifications.

Features such as the Traction Control System help to maintain contact with the road, whilst anti-theft protection provides added security, all offering greater assistance and protection when you're out on the road. Passive safety features include a driver's airbag, which is standard across the range with the option of passenger, side and curtain airbags.

These are some of the safety features available, but please refer to particular model specifications for which feature is available on which model:

- ABS\*
- TCS\*
- EBC\*
- EBD\*
- Driver and passenger airbags
- Side and curtain airbags
- Third brake light
- Automatic hazard lights activation under emergency braking standard on Crafter.

Add to all these independent suspension, stable road holding and responsive engines and you can be sure that you'll be as safe as we can make you. The rest is up to you!

Engineered for you™ – bespoke conversions.

Engineered for you™ provides bespoke conversions from a select range of accredited converters. This way you can specify a vehicle to suit your requirements, assured of the build quality and service you will receive. These accredited converters have to meet our stringent tests, not only

technically, but also in aftersales support, financial stability and so on. This is the only way we can be confident that you will be as happy with the conversion as you are with the base vehicle.



Accredited converters.	Conversion type
Advanced Vehicle Builders	Minibus
Aire Truck Bodies Ltd	Standard and specials
AJ Engineering	Police vehicles
AL-KO Kober	Chassis conversions
Auto Electrical Services Ltd	Police vehicles
Boalloy Fastruck Ltd	Lutons
Bott Ltd	Racking and conversions
Bri-Stor Systems Ltd	Racking and conversions
Brotherwood Automobility Ltd	Wheelchair vehicles
Chassis Developments	Chassis converters
Cold Consortium	Temperature controlled vehicles
CoTrim Conversions	Wheelchair vehicles
Crown Conversions	Police and others
Gerd BAeR	Chassis converters
Glide-Rite Products	Air suspension
GRP Group	Temperature controlled vehicles
Ingimex	Tippers and dropsides
Kinetic Special Vehicles	Police vehicles
Minibus Options	Minibus
Oughtred and Harrison (Facilities)	Minibus and ambulance
Premier Vehicle Solutions	Taxi, bus and crew vans
Somers Refrigeration	Temperature controlled vehicles
Taxi and Bus Conversions Ltd	Taxis and buses
TVAC	Chassis converters
VB Air Suspension	Air suspension
Verve Bodyshop	Commercial and PSV
Woodall Nicholson	Police and minibus





12 13 Image 01 shows Transporter chassis cab with optional dropside body.  
Image 02 shows Crafter chassis cab with optional dropside body, ladder carrier and towbar.

## So which model is for me?

You probably already know roughly what you'll need to carry. What is the biggest, or the heaviest, or the longest or just the most awkward thing you'll need to carry? If you're a fleet manager, then you'll probably need a variety of options!

Having this in mind should help you to choose either the Transporter or the Crafter chassis as a starting point. The 'Quick Reference Guide' on page 5 will come in handy, so will the fold-out 'Build your vehicle' page at the back of this brochure.

Remember, this brochure only covers chassis and double cabs, together with their factory-fitted options. There are also separate brochures for our panel van and passenger-carrier ranges. There is also an accessories brochure for you to further enhance your van.

Now let's take a more detailed look at each model in the chassis and double cab range so you can begin to make your choice...



02



## Summary of the Volkswagen chassis and double cab range.

Model	Gross vehicle weight kg	Wheelbase mm	Chassis cab	Double cab
<b>Transporter.</b>				
T30	3,000	3,400		
<b>Transporter with optional dropside.</b>				
T30	3,000	3,400		
<b>Crafter.</b>				
CR35	3,500	3,665		
		4,325		
CR50	5,000	3,665		
		4,325		
<b>Crafter with optional dropside.</b>				
CR35	3,500	3,665		
		4,325		
CR50	5,000	3,665		
		4,325		

Indicates models fitted with optional equipment.



## The Volkswagen Transporter.



01

The world-renowned Transporter has grown a solid reputation from year to year, winning many awards along the way. Packed full of innovative ideas, the latest Transporter is even better equipped than any of its predecessors. And that's not surprising. You'd be hard pushed to fault this vehicle - its versatility, features, specification and overall good looks make it a winner for all kinds of businesses, and for all kinds of reasons.

The Transporter is available as either a chassis or double cab, and a factory-fitted dropside body can be ordered on all models.

As an example of the outstanding technology that has been invested in this range, there are three innovative and extremely economical TDI 'Pumpe Duese' (PD) diesel engines. These provide outstanding load-pulling capability, great fuel economy, and make the Transporter an absolute pleasure to drive.

The main features of the Transporter chassis are:

- Long wheelbase
- 3.0t gross vehicle weight
- Optional factory-fitted dropside
- 3 TDI PD diesel engines from 84PS to 130PS.

More detailed specifications and options can be found on the following pages.

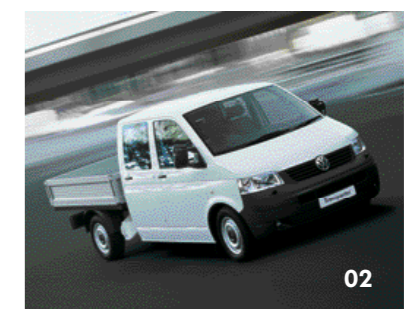

02



03

Image 02 shows Transporter double cab with optional dropside body.  
Image 03 shows Transporter chassis cab with optional dropside body.



# Transporter chassis and double cab standard specifications.

## Body.

- 80 litre lockable fuel tank
- Black wheel centre caps
- Externally adjustable exterior mirrors:
  - Convex on brace on driver and passenger side
  - Suitable for bodies up to 1,994mm
- Front towing eye
- Galvanised full steel body
- Grey bumpers
- Heat reflective glass
- Jack and tool kit with steel spare wheel
- Ladder frame at rear

## Interior.

- Cab area:**
  - 2 folding and pivoted sun visors
  - Dash mounted gear lever
  - Driver's seat with height, lumbar, reach and rake adjustment
  - Dual passenger seat with storage box
  - 'Inca' fabric seat covers
  - Interior light
  - Rear view mirror with anti-dazzle function
  - Rubber floor covering
- Storage:
  - 2 storage compartments in dash panel
  - 2 storage compartments in driver's door
  - 2 storage compartments in passenger door
  - Drinks holder
  - Lockable glove compartment
  - Open storage compartment in dash panel including mobile phone holder
  - Overhead storage
  - Storage net on lower dash passenger side
- Double cab passenger area:**
  - 2 side doors with fixed windows
  - 3-seater bench with storage underneath
  - Childlocks
  - Interior entry steps
  - Interior roof and side trim in grey painted hardboard
  - Rubber floor covering

## Functional.

- 12V socket
- Digital clock
- Manually controlled heating system with dust and pollen filter and air recirculation
- Radio/single CD player (2 DIN) with 2 speakers
- Remote central locking with deadlocks and 2 remote keys
- Rev counter
- Warning buzzer for lights left on
- Windscreen wiper with variable intermittent delay and wash/wiper system

## Technical.

- Front and rear axle:
  - Anti-roll bars, front and rear
  - Front McPherson strut suspension
  - Independent suspension
  - Rear miniblock springs
  - Telescopic shock absorbers
- Hydraulic brake system with ventilated disc brakes
- Power steering
- Steel wheels: 6.5J x 16
- Tyres: 205/65 R16 (on 84 and 102PS versions) 215/65 R16 (on 130PS version)

## Safety and security.

- ABS: Anti-lock Braking System
- Breaksafe steering wheel lock
- Driver and passenger airbags
- EBC: Engine Braking Control
- EBD: Electronic Brakeforce Distribution
- Electronic immobiliser 'Transponder'
- Halogen main headlights with range control
- Height adjustable head restraints
- Height adjustable, tensioning seat belts for all outer cab seats
- Height and rake adjustable safety steering column
- Rear fog light
- TCS: Traction Control System
- Three-point inertia reel seat belts for all seats



Radio/CD player.



Halogen headlights.



Dash mounted gear lever.



Storage in driver and front passenger doors.



Remote central locking.



Driver and passenger airbags.



## Transporter chassis and double cab recommended retail prices.

Model			Manufacturer's RRP			Ins. group**		
			Basic retail excluding VAT £ †	VAT £ †	Total retail including VAT £ †		Total retail including OTR* excluding VAT £ †	including VAT £ †
<b>Chassis cab long wheelbase.</b>								
<b>T30</b>	84PS TDI PD	7JL162	14,830.00	2,224.50	17,054.50	15,640.00	17,950.00	<b>6E-T2</b>
	102PS TDI PD	7JL172	15,550.00	2,332.50	17,882.50	16,360.00	18,778.00	<b>6E-T2</b>
	130PS TDI PD	7JL101	16,750.00	2,512.50	19,262.50	17,560.00	20,158.00	<b>6E-T2</b>
<b>Double cab long wheelbase.</b>								
<b>T30</b>	102PS TDI PD	7JD172	16,830.00	2,524.50	19,354.50	17,640.00	20,250.00	<b>6E-T2</b>
	130PS TDI PD	7JD101	18,030.00	2,704.50	20,734.50	18,840.00	21,630.00	<b>6E-T2</b>

\*OTR (on the road) package for chassis and double cabs includes the following:  
 Delivery to retailer £550.00  
 Number plates £20.00  
 VAT £85.50  
 Road fund licence £185.00  
 First registration fee £55.00  
**Total £895.50**

† Calculated at 15% on all products.

\*\* Insurance group: As advised by the Association of British Insurers (ABI). Please see [www.abi.org.uk/carinsurance](http://www.abi.org.uk/carinsurance) for more information.



Storage compartment in headlining.



Cloth seat upholstery.

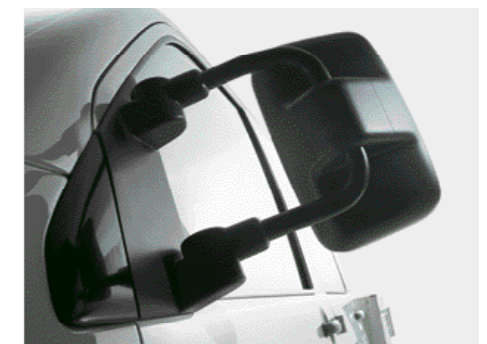

Extended door mirrors.

## Transporter chassis and double cab factory options.

	LWB		Manufacturer's RRP		
	Chassis cab	Double cab	Basic retail excluding VAT £ †	VAT £ †	Total retail including VAT £ †
	T30	T30			
<b>Paint options.</b>					
<b>Metallic and pearl paint</b>	•	•	475.00	71.25	546.25
<b>Black paint</b> - 9000	•	•	275.00	41.25	316.25
<b>Danish blue paint</b> - 9506	•	•	100.00	15.00	115.00
<b>Stone blue paint</b> - 9544	•	•	100.00	15.00	115.00
<b>Factory fitted options.</b>					
<b>Alloy wheels</b> - 'Cartagena' 16" with 215/65 R16 tyres, 4 with steel spare (84/102PS engines only)	•	•	510.00	76.50	586.50
<b>Alloy wheels</b> - 'Cartagena' 16", 4 with steel spare (130PS engines only)	•	•	420.00	63.00	483.00
<b>Alloy wheels</b> - 'Miyato' 16" with 215/65 R16 tyres, 4 with steel spare (84/102PS engines only)	•	•	445.00	66.75	511.75
<b>Alloy wheels</b> - 'Miyato' 16", 4 with steel spare (130PS engines only)	•	•	345.00	51.75	396.75
<b>Alloy wheels</b> - 'Thunder' 17" with 235/55 R17 tyres, 4 with steel spare (130PS engines only, not with tyres - all weather)	•	•	910.00	136.50	1,046.50
<b>Battery</b> - second 72Ah	•	•	125.00	18.75	143.75
<b>Cruise control</b>	•	•	160.00	24.00	184.00
<b>Dropside body</b> - alloy	•	•	700.00	105.00	805.00
<b>ESP</b> †	•	•	295.00	44.25	339.25
<b>Fog lights</b> - front	•	•	135.00	20.25	155.25
<b>Heated rear cab window</b>	•	•	15.00	2.25	17.25
<b>Mud flaps</b> - front and rear (only with dropside body)	•	•	90.00	13.50	103.50
<b>Parking brake</b> - hill hold control (includes ESP)	•	•	335.00	50.25	385.25
<b>Smoking pack</b> - ashtray, cigarette lighter and cup holder	•	•	15.00	2.25	17.25
<b>Tachograph</b> - digital, includes console on dash	•	•	440.00	66.00	506.00
<b>Towbar</b> - fixed ball with 13 pin socket †	•	•	340.00	51.00	391.00
<b>Trip computer</b> (included with satellite navigation)	•	•	105.00	15.75	120.75
<b>Tyres</b> - all weather, 215/65 R16 (84/102PS engines only)	•	•	185.00	27.75	212.75
<b>Tyres</b> - all weather (130PS engines only, not with alloy wheels - 'Thunder' 17")	•	•	85.00	12.75	97.75
<b>Airbag packs.</b>					
<b>Airbag pack C</b> - side and front curtain airbags (only with seat pack B)	•	•	230.00	34.50	264.50
<b>Heating and ventilation.</b>					
<b>Air conditioning pack A</b> - manual, dash †	•	•	640.00	96.00	736.00
<b>Charcoal canister</b> - for ventilation system	•	•	15.00	2.25	17.25



16" 'Miyato' alloy wheels.



17" 'Thunder' alloy wheels.



Cruise control.



Dropside body - alloy.



Comfort seats for driver and front passenger.



Satellite navigation system.

	LWB		Manufacturer's RRP		
	Chassis cab	Double cab	Basic retail excluding VAT £ †	VAT £ †	Total retail including VAT £ †
	T30	T30			
<b>Options packs.</b>					
<b>Alarm pack A</b> - perimeter with back-up horn †	•	•	125.00	18.75	143.75
<b>Alarm pack B</b> - with interior (cab only) and tow away protection †	•	•	145.00	21.75	166.75
<b>Cab comfort pack</b> †	•	-	200.00	30.00	230.00
<b>Electric pack A</b> - electric windows with electrically heated and adjustable mirrors	•	•	295.00	44.25	339.25
<b>Satellite navigation A</b> - monochrome screen, includes trip computer †, †	•	•	1,165.00	174.75	1,339.75
<b>Satellite navigation B</b> - colour screen, includes trip computer †, †	•	•	1,770.00	265.50	2,035.50
<b>Visibility pack A</b> - headlamp washers, fluid level indicator and heated washer jets	•	•	160.00	24.00	184.00
<b>Visibility pack B</b> - rain sensor and automatic dimming rear view mirror	•	•	85.00	12.75	97.75
<b>Seat packs.</b>					
<b>Seats</b> - leatherette upholstery	•	•	25.00	3.75	28.75
<b>Seats</b> - robust upholstery (only with seat pack B, not double cab)	•	-	80.00	12.00	92.00
<b>Seat pack A</b> - driver's comfort seat †	•	•	50.00	7.50	57.50
<b>Seat pack B</b> - driver and single passenger comfort seats †	•	•	15.00	2.25	17.25
<b>Seat pack F</b> - heated driver's seat †	•	•	110.00	16.50	126.50
<b>Seat pack G</b> - heated driver and front passenger seats †	•	•	220.00	33.00	253.00

- Options.
- Not available.

† Calculated at 15% on all products.

<sup>1</sup> **ESP**: Also includes Active Rollover Protection (ARP), maximum brake support (more braking power for fully loaded vehicles), prefill (to reduce stopping distance/time), fading brake support and improved hydraulic brake assist.

<sup>2</sup> **Towbar**: An adaptor is available from Van Centres, to allow connection to twin 7 pin sockets.

<sup>3</sup> Battery uprated to 80Ah on 84/102PS engines, 95Ah on 130PS engines.

<sup>4</sup> Battery uprated to 95Ah.

<sup>5</sup> **Cab comfort pack**: 'Box' fabric seat trim, carpet in cab, storage compartments in outer side of driver and passenger seats, vanity mirrors, sunglasses holder, interior light delay, 2 reading lights, instrument dimmer, grab handles on 'A' pillars, two tone horn and additional noise suppression measures.

<sup>6</sup> **Satellite navigation A**: Replaces radio/in-dash CD player, includes RDS radio function with single CD and CD changer control, where fitted (audio CDs cannot be played when using navigation function).

<sup>7</sup> **Satellite navigation B**: Replaces radio/in-dash CD player, includes RDS radio function and CD changer control, where fitted (audio CDs cannot be played).

<sup>8</sup> **Comfort seat**: Adds armrest (height adjustment and lumbar support standard for driver's seat).

<sup>9</sup> **Comfort seats**: Add armrests for both front seats, passenger height adjustment and lumbar support (height adjustment and lumbar support standard for driver's seat).

<sup>10</sup> **Uprated alternator**: 120A on 84/102PS engines, 150A on 130PS engines.



# Transporter chassis and double cab dimensions and weights.

## Chassis cab long wheelbase.

Unbodied.

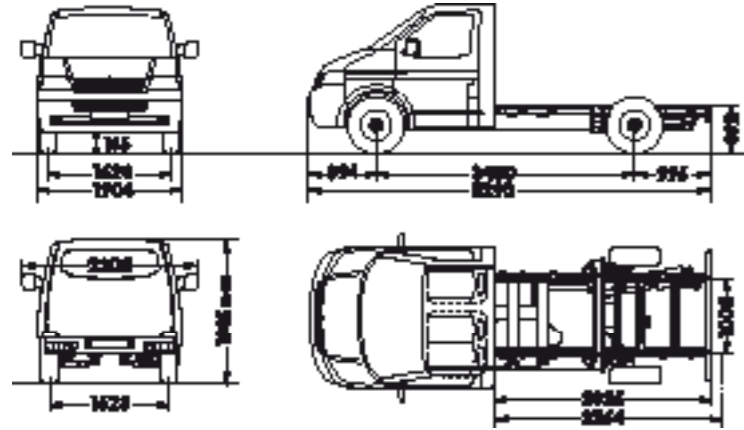

Wheelbase	3,400
Turning circle (wall to wall)	13.2m
Dimensions in mm unless otherwise indicated.	

Optional dropside.

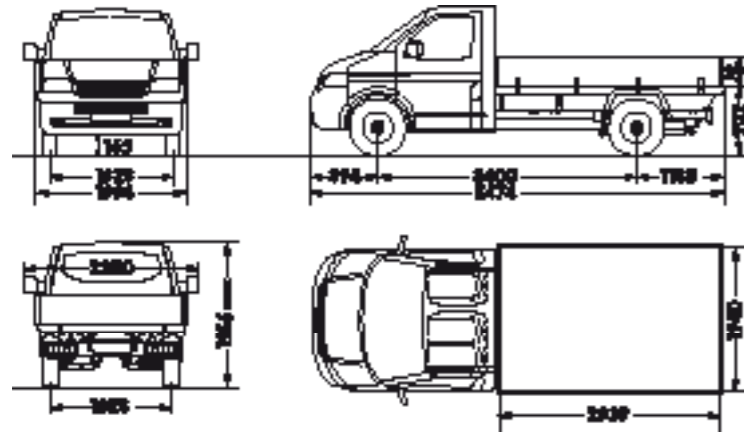

Wheelbase	3,400
Load area length	2,939
Load area width	1,940
Load area height	392
Load area	5.7m <sup>2</sup>
Turning circle (wall to wall)	13.2m
Dimensions in mm unless otherwise indicated.	

## Double cab long wheelbase.

Unbodied.

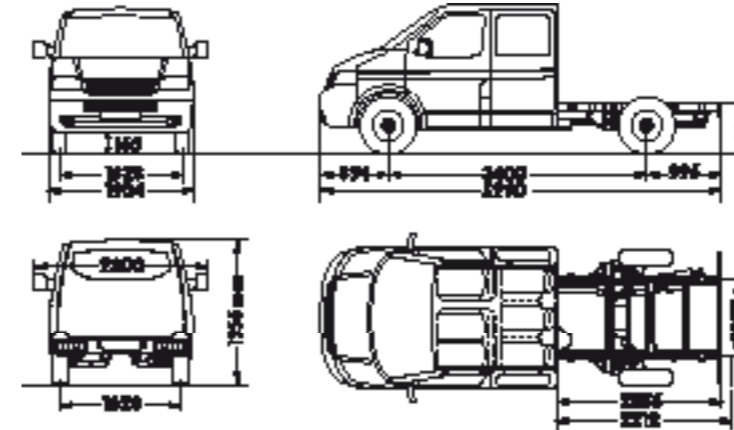

Wheelbase	3,400
Turning circle (wall to wall)	13.2m
Dimensions in mm unless otherwise indicated.	

Optional dropside.

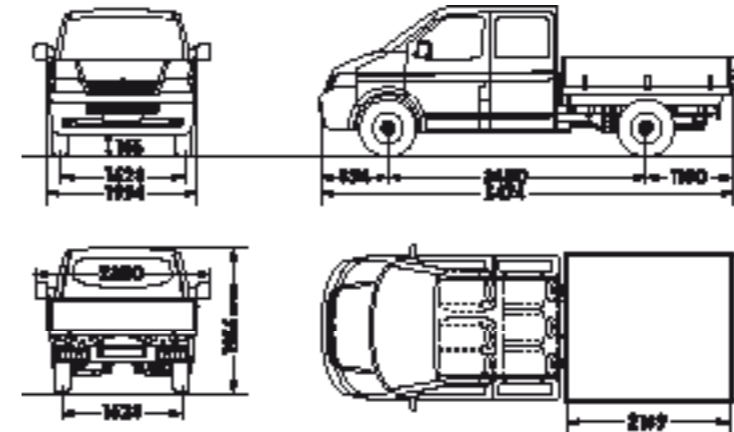

Wheelbase	3,400
Load area length	2,169
Load area width	1,940
Load area height	392
Load area	4.2m <sup>2</sup>
Turning circle (wall to wall)	13.2m
Dimensions in mm unless otherwise indicated.	

The height measurements listed here may vary by ± 50mm depending on equipment fitted. For body building information please refer to attachment guidelines on Volkswagen Commercial Vehicles website: [www.volkswagen-vans.co.uk](http://www.volkswagen-vans.co.uk)

Model	Gross vehicle weight kg	Engine	Axle load limit front / rear kg	Trailer weight braked / unbraked* kg	Gross train weight kg	Unladen weight** kg	Payload*** kg
T30	3,000	84PS TDI PD	1,490 / 1,680	2,200 / 750	4,800	1,740 (1,925)	<b>1,260 (1,075)</b>
		102PS TDI PD	1,490 / 1,680	2,500 / 750	5,200	1,740 (1,925)	<b>1,260 (1,075)</b>
		130PS TDI PD	1,575 / 1,680	2,500 / 750	5,200	1,815 (2,000)	<b>1,185 (1,000)</b>

Model	Gross vehicle weight kg	Engine	Axle load limit front / rear kg	Trailer weight braked / unbraked* kg	Gross train weight kg	Unladen weight** kg	Payload*** kg
T30	3,000	102PS TDI PD	1,575 / 1,680	2,500 / 750	5,200	1,783 (1,933)	<b>1,217 (1,067)</b>
		130PS TDI PD	1,575 / 1,680	2,500 / 750	5,200	1,857 (2,007)	<b>1,143 (993)</b>

Figures in brackets on weight tables indicate optional dropside weights where different.

Trailer nose weight is 100kg.

Roof load limit is maximum 50kg (chassis cab) and 75kg (double cab)

\* For 12% gradient.

\*\* Unladen weight includes full tank of fuel, excludes crew.

\*\*\* Payload with full tank of fuel, excluding crew. Payload = gross vehicle weight - unladen weight.

Weights are for vehicles with standard specification. The addition of factory options or Volkswagen Van Centre fitted accessories may affect unladen weight and payload.

## VAT information.

The VAT paid on vans can usually be recovered if the vehicle is purchased by a VAT registered business. However VAT incurred on the purchase of vans fitted with windows and/or seats to the rear of the driver cannot be recovered unless the vehicle payload meets or exceeds 1,000kg. Otherwise VAT incurred on these vehicles is not available for recovery unless the vehicle is used for 100% business purposes. It is the customer's responsibility to deal with the VAT correctly. Customers should always seek professional advice to establish their own personal tax position.



## Transporter chassis and double cab engine specifications.

	84PS TDI PD	102PS TDI PD	130PS TDI PD
Engine type	Transverse, water cooled in line variable turbine geometry turbocharger with intercooler		
Mixture preparation/injection method	Unit injector pump direct injection		
Exhaust emission standard	EU 4		
No. of cylinders	4		5
Cubic capacity, cm <sup>3</sup>	1,896		2,460
Output, PS at rpm	84 at 3,500	102 at 3,500	130 at 3,500
Torque, max. Nm/rpm	200/2,000	250/2,000	340/2,000
Diesel particulate filter	◦	◦	•
5-speed manual gearbox	•	•	-
6-speed manual gearbox	-	-	•
Front wheel drive	•	•	•

### Electrics.

Alternator	90A	150A
Battery	61Ah (330A)	72Ah (380A)

- Available
- Not available
- Optional

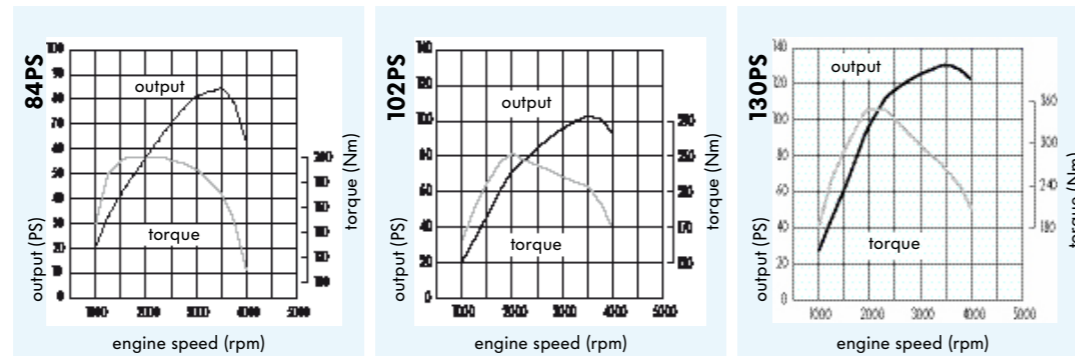

## Chassis and double cab fuel consumption and performance.

Model	Engine	Urban <sup>1</sup> mpg (l/100km)	Extra urban <sup>1</sup> mpg (l/100km)	Combined <sup>1</sup> mpg (l/100km)	Acceleration 0-62 mph	Top speed (where the law permits) mph
<b>Chassis and double cab.</b> (fuel consumption and performance dependent on body fitted)						
<b>Chassis and double cab<sup>2</sup> with optional dropside.</b> (T30 long wheelbase only)						
<b>LWB</b>	84PS TDI PD	28.0 (10.1)	37.2 (7.6)	33.2 (8.5)	24.6	83
	102PS TDI PD	28.2 (10.0)	39.2 (7.2)	34.4 (8.2)	19.1 [19.3]	88 [91]
	130PS TDI PD	26.2 (10.8)	38.2 (7.4)	32.8 (8.6)	15.7 [15.8]	95 [98]

Figures in square brackets are for double cab models, where different.

<sup>1</sup> With 50% payload and 80 litre fuel tank capacity.

<sup>2</sup> 84PS not available on double cab models.

## The Volkswagen Crafter.



01

The latest and largest addition to the Volkswagen range, the Crafter's chunky good looks only partially reveal its underlying strengths. Four powerful BlueTDI engines with enough torque to satisfy the most demanding business users make the Crafter the chassis of choice for many conversions.

And it is choice that marks the Crafter out as special. Whatever your basic load-carrying requirement is, be it length, weight, size or anything else, there is a Crafter chassis ready for a conversion that will do the job. The Crafter chassis is also

available as a double cab, or with a factory-fitted aluminium dropside body.

We detail more of those choices on the following pages, but these are primary choices you get from a Crafter chassis:

- Chassis cab, double cab and optional factory-fitted dropside
- 2 wheelbase options (double cab LWB only)
- 2 gross vehicle weights
- Range of four BlueTDI common-rail diesel engines.

And these features are standard across the range:

- ABS\*
- ESP\* (load adjusting)
- TCS\*.

Other features and options are listed on the following pages.

\* Please refer to the glossary on page 49 of this brochure.



02



Image 02 shows Crafter double cab with optional dropside body, front fog lights and sunroof.

# Crafter chassis and double cab standard specifications.

## Body.

- 30 litre AdBlue® tank
- 75 litre fuel tank with lockable cap
- Black bumpers with integrated front step
- Black wheel centre caps
- Externally adjustable external convex mirrors with indicators
- Front and rear towing eyes, (front only on CR50 and double cab)
- Heat reflective glass
- Mirrors:
  - Convex on brace on driver and passenger side (CR50 only)
- Roof marker lights
- Preparation for side marker lights (MWB and LWB only)
- Tyre repair kit and compressor

## Interior.

- |  |  |   |
|--|--|---|
| <p><b>Cab area:</b></p> <ul style="list-style-type: none"> <li>• 2 folding and pivoted sun visors</li> <li>• Driver's seat with height, reach and rake adjustment</li> <li>• Dual passenger seat with storage box and folding tray in backrest</li> <li>• Grab handles</li> <li>• 'Inca' fabric seat covers</li> <li>• Interior light (including 2 reading lights)</li> <li>• Rubber floor covering</li> </ul> | <p>• Storage:</p> <ul style="list-style-type: none"> <li>- 5 drinks holders</li> <li>- Document holder on centre console</li> <li>- Glove compartment</li> <li>- Overhead storage (max load 5kg)</li> <li>- Storage compartment in right step</li> <li>- Storage compartments (open and closed) in doors</li> <li>- Storage tray in centre console</li> <li>- Storage tray on dashboard</li> </ul> | <p><b>Double cab passenger area:</b></p> <ul style="list-style-type: none"> <li>• 2 side doors</li> <li>• 4-seat bench with storage box</li> <li>• Childlocks</li> <li>• Hinged side windows</li> <li>• Interior entry steps</li> </ul> |
|--|--|---|

## Functional.

- |  |  |   |
|--|--|---|
| <ul style="list-style-type: none"> <li>• 12V socket</li> <li>• Digital clock</li> <li>• Digital tachograph (CR50 only)</li> <li>• Dimmable dashboard illumination</li> <li>• Electric windows</li> </ul> | <ul style="list-style-type: none"> <li>• Manually controlled heating system with charcoal filter and air recirculation</li> <li>• Radio/single CD player, MP3 compatible with 5 speakers</li> <li>• Remote central locking with 2 remote keys</li> </ul> | <ul style="list-style-type: none"> <li>• Rev counter</li> <li>• Speed limiter 56mph (90km/h) (CR50 models)</li> <li>• Warning buzzer for lights left on</li> <li>• Windscreen wiper with variable intermittent delay and wash/wiper system</li> </ul> |
|--|--|---|

## Technical.

- |   |   |   |
|---|---|---|
| <ul style="list-style-type: none"> <li>• Bulb failure monitor deactivation</li> <li>• Front and rear axle:                     <ul style="list-style-type: none"> <li>- Anti-roll bar, front (front and rear on all CR50)</li> <li>- Front transverse leaf spring independent suspension</li> <li>- Rear rigid axle with leaf springs (CR35 chassis and double cabs - double leaf, CR50 - triple leaf)</li> <li>- Telescopic shock absorbers</li> </ul> </li> </ul> | <ul style="list-style-type: none"> <li>• Hydraulic brake system with front ventilated and rear solid disc brakes (front and rear ventilated on CR50)</li> <li>• Power steering</li> <li>• Rear wheels:                     <ul style="list-style-type: none"> <li>- Single: CR35</li> <li>- Twin: CR50</li> </ul> </li> </ul> | <ul style="list-style-type: none"> <li>• Steel wheels: 51/2J x 16 (CR50 only) 61/2J x 16 (CR35 only)</li> <li>• Tyres: 235/65 R16C (CR35 only) 195/75 R16C (CR50 only)</li> </ul> |
|---|---|---|

## Safety and security.

- |   |  |   |
|---|--|---|
| <ul style="list-style-type: none"> <li>• ABS: Anti-lock Braking System</li> <li>• Automatic hazard lights activation under emergency braking</li> <li>• Brake pad wear, failure and fluid level indicators</li> <li>• Driver's airbag</li> <li>• EBA: Electronic Brake Assist</li> <li>• EBD: Electronic Brakeforce Distribution</li> </ul> | <ul style="list-style-type: none"> <li>• EDL: Electronic Differential Lock</li> <li>• ESP: Electronic Stabilisation Programme - load adjusting</li> <li>• Electronic steering wheel lock</li> <li>• Engine immobiliser 'Transponder'</li> <li>• Halogen main headlights with headlight range control</li> <li>• Height adjustable head restraints</li> </ul> | <ul style="list-style-type: none"> <li>• Height adjustable seat belts for all outer cab seats</li> <li>• Rear fog light</li> <li>• Seat belt warning light for driver</li> <li>• TCS: Traction Control System</li> <li>• Thatcham Category 1 alarm with interior and tow-away protection and back-up horn</li> <li>• Three point inertia reel seat belts for all seats</li> </ul> |
|---|--|---|



Document holder.



Fold down tray - integral to dual passenger seat.



ESP.



Overhead console with two reading lights.



Overhead storage.



Radio/CD player.



Engineered to go™ is a top quality range of the most common body conversions such as tippers, dropsides and Lutons that are requested by our customers. Built either by Boalloy or Ingimex, two of the UK's leading bodybuilders, they are readily

available on order from any of our Van Centres. Products from these two companies are recognised for their quality and durability, benefits which enhance the residual value of the vehicle and are listed within CAP price guide.



Engineered to go™ Ingimex tippers built on Crafter chassis and double cabs are available from your local Van Centre.



Engineered to go™ Ingimex dropsides built on Crafter chassis and double cabs are available from your local Van Centre.



Engineered to go™ Luton bodies, built by Boalloy Fastruck are available on Crafter chassis cabs and can be purchased from your local Van Centre.

## Crafter chassis and double cab recommended retail prices.

Model	Manufacturer's RRP					Ins. group**		
	Basic retail excluding VAT £ †	VAT £ †	Total retail including VAT £ †	Total retail excluding VAT £ †	Total retail including OTR* including VAT £ †			
<b>Chassis cab medium wheelbase.</b>								
<b>CR35</b>	88PS BlueTDI	2FF4A5	20,490.00	3,073.50	23,563.50	21,240.00	24,399.00	9E
	109PS BlueTDI	2FF4B5	21,690.00	3,253.50	24,943.50	22,440.00	25,779.00	9E
	109PS BlueTDI Shiftmatic	2FF4BA	22,440.00	3,366.00	25,806.00	23,190.00	26,641.50	9E
	136PS BlueTDI	2FF4C5	22,590.00	3,388.50	25,978.50	23,340.00	26,814.00	9E
	163PS BlueTDI	2FF4D5	23,790.00	3,568.50	27,358.50	24,540.00	28,194.00	9E
<b>CR50</b>	109PS BlueTDI	2FF5B5	26,020.00	3,903.00	29,923.00	26,810.00	30,798.50	N/A
	136PS BlueTDI	2FF5C5	26,950.00	4,042.50	30,992.50	27,740.00	31,868.00	N/A
	136PS BlueTDI Shiftmatic	2FF5CA	27,700.00	4,155.00	31,855.00	28,490.00	32,730.50	N/A
	163PS BlueTDI	2FF5D5	27,880.00	4,182.00	32,062.00	28,670.00	32,937.50	N/A
<b>Chassis cab long wheelbase.</b>								
<b>CR35</b>	88PS BlueTDI	2FL4A5	21,020.00	3,153.00	24,173.00	21,770.00	25,008.50	9E
	109PS BlueTDI	2FL4B5	22,220.00	3,333.00	25,553.00	22,970.00	26,388.50	9E
	109PS BlueTDI Shiftmatic	2FL4BA	22,970.00	3,445.50	26,415.50	23,720.00	27,251.00	9E
	136PS BlueTDI	2FL4C5	23,120.00	3,468.00	26,588.00	23,870.00	27,423.50	9E
	163PS BlueTDI	2FL4D5	24,320.00	3,648.00	27,968.00	25,070.00	28,803.50	9E
<b>CR50</b>	109PS BlueTDI	2FL5B5	26,550.00	3,982.50	30,532.50	27,340.00	31,408.00	N/A
	136PS BlueTDI	2FL5C5	27,480.00	4,122.00	31,602.00	28,270.00	32,477.50	N/A
	136PS BlueTDI Shiftmatic	2FL5CA	28,230.00	4,234.50	32,464.50	29,020.00	33,340.00	N/A
	163PS BlueTDI	2FL5D5	28,410.00	4,261.50	32,671.50	29,200.00	33,547.00	N/A
<b>Double cab long wheelbase.</b>								
<b>CR35</b>	109PS BlueTDI	2FM4B5	23,580.00	3,537.00	27,117.00	24,330.00	27,952.50	9E
	109PS BlueTDI Shiftmatic	2FM4BA	24,330.00	3,649.50	27,979.50	25,080.00	28,815.00	9E
	136PS BlueTDI	2FM4C5	24,480.00	3,672.00	28,152.00	25,230.00	28,987.50	N/A
<b>CR50</b>	109PS BlueTDI	2FM5B5	28,170.00	4,225.50	32,395.50	28,960.00	33,271.00	N/A
	109PS BlueTDI Shiftmatic	2FM5BA	28,920.00	4,338.00	33,258.00	29,710.00	34,133.50	N/A
	136PS BlueTDI	2FM5C5	29,100.00	4,365.00	33,465.00	29,890.00	34,340.50	N/A

\*OTR (on the road) package for CR35 chassis and double cabs includes the following:  
 Delivery to retailer £550.00  
 Number plates £20.00  
 VAT £85.50  
 Road fund licence £125.00  
 First registration fee £55.00  
**Total £835.50**

\*OTR (on the road) package for CR50 chassis and double cabs (HGV, Band A) includes the following:  
 Delivery to retailer £550.00  
 Number plates £20.00  
 VAT £85.50  
 Road fund licence £165.00  
 First registration fee £55.00  
**Total £875.50**

† Calculated at 15% on all products.

\*\* Insurance group: As advised by the Association of British Insurers (ABI). Please see [www.abi.org.uk/carinsurance](http://www.abi.org.uk/carinsurance) for more information.



## Crafter chassis and double cab factory options.

	MWB		LWB				Manufacturer's RRP		
	chassis cab				double cab		Basic retail excluding VAT £ †	VAT £ †	Total retail including VAT £ †
	CR35	CR50	CR35	CR50	CR35	CR50			
<b>Paint options.</b>									
Deep black paint - 3902	•	•	•	•	•	•	375.00	56.25	431.25
Metallic paint	•	•	•	•	•	•	700.00	105.00	805.00
Pearl paint	•	•	•	•	•	•	750.00	112.50	862.50
Danish blue paint - 9506	•	•	•	•	•	•	100.00	15.00	115.00
<b>Factory fitted options.</b>									
Alloy wheels (CR35 only)	•	-	•	-	•	-	420.00	63.00	483.00
Alternator - uprated 180A (not with battery - uprated or heated windscreen, included with air conditioning)	•	•	•	•	•	•	115.00	17.25	132.25
Alternator/Battery - uprated (not with heated windscreen, tachograph - digital or CR50)	•	-	•	-	•	-	140.00	21.00	161.00
Battery - uprated 110Ah (not with alternator - uprated, heated windscreen or tachograph - digital, not CR50)	•	-	•	-	•	-	30.00	4.50	34.50
Bulb failure monitor, warning light	•	•	•	•	•	•	25.00	3.75	28.75
Cruise control	•	•	•	•	•	•	190.00	28.50	218.50
Electric mirrors - heated and adjustable	•	•	•	•	•	•	135.00	20.25	155.25
Factory dropside body - alloy, includes side marker lights									
CR35 MWB chassis cabs	•	-	-	-	-	-	975.00	146.25	1,121.25
CR50 MWB chassis cabs	-	•	-	-	-	-	1,365.00	204.75	1,569.75
CR35 LWB chassis cabs	-	-	•	-	-	-	1,305.00	195.75	1,500.75
CR50 LWB chassis cabs	-	-	-	•	-	-	1,710.00	256.50	1,966.50
CR35 double cabs	-	-	-	-	•	-	1,440.00	216.00	1,656.00
CR50 double cabs	-	-	-	-	-	•	1,645.00	246.75	1,891.75
Fog lights - front, integrated in bumper	•	•	•	•	•	•	100.00	15.00	115.00
Headlight washers	•	•	•	•	•	•	180.00	27.00	207.00
Heated windscreen (only with visibility pack, not with alternator - uprated, alternator/battery uprated or battery - uprated)	•	•	•	•	•	•	135.00	20.25	155.25
Keys - 2 additional keys	•	•	•	•	•	•	50.00	7.50	57.50
Ladder carrier - on front panel (only with factory dropside body - alloy fitted)	•	•	•	•	•	•	260.00	39.00	299.00
Ladder carrier - rear (only with factory dropside body - alloy fitted)	•	•	•	•	•	•	130.00	19.50	149.50
Ladder carrier - front and rear (only with factory dropside - alloy fitted)	•	•	•	•	•	•	390.00	58.50	448.50

	MWB		LWB				Manufacturer's RRP		
	chassis cab				double cab		Basic retail excluding VAT £ †	VAT £ †	Total retail including VAT £ †
	CR35	CR50	CR35	CR50	CR35	CR50			
<b>Factory fitted options. (continued)</b>									
Mud flaps - front	•	•	•	•	•	•	25.00	3.75	28.75
Mud flaps - front and rear (only with factory dropside body - alloy fitted)	•	•	•	•	•	•	50.00	7.50	57.50
Parking brake - hill hold control (standard on Shiftmatic)	•	•	•	•	•	•	60.00	9.00	69.00
Rear window in cab - with dipping rear view mirror	•	•	•	•	•	•	55.00	8.25	63.25
Satellite navigation A - colour screen with arrow navigation (CD)	•	•	•	•	•	•	1,030.00	154.50	1,184.50
Satellite navigation B - colour screen with map navigation (DVD)	•	•	•	•	•	•	1,620.00	243.00	1,863.00
Spare wheel - steel	•	•	•	•	•	•	0.00	0.00	0.00
Speed limiter 90km/h (standard on CR50)	•	s	•	s	•	s	35.00	5.25	40.25
Speed limiter 100km/h (not CR50)	•	-	•	-	•	-	35.00	5.25	40.25
Speed limiter 120km/h (not CR50)	•	-	•	-	•	-	35.00	5.25	40.25
Steering wheel - height and reach adjustable	•	•	•	•	•	•	60.00	9.00	69.00
Steering wheel - multi-function, includes trip computer (included with satellite navigation packs)	•	•	•	•	•	•	210.00	31.50	241.50
Sunroof - in cab, sliding/tilting, electric	•	•	•	•	•	•	455.00	68.25	523.25
Tachograph - digital (standard on CR50)	•	s	•	s	•	s	400.00	60.00	460.00
Temperature display - external (included with air conditioning, satellite navigation packs and steering wheel - multi-function)	•	•	•	•	•	•	85.00	12.75	97.75
Tyre pressure warning light (CR35 only)	•	-	•	-	•	-	260.00	39.00	299.00
Tyres - all weather	•	-	•	-	•	-	85.00	12.75	97.75
<b>Options packs.</b>									
Visibility pack - rain sensor, headlamp washers and automatic light sensor	•	•	•	•	•	•	300.00	45.00	345.00
<b>Airbag packs.</b>									
Airbag pack A - passenger	•	•	•	•	•	•	210.00	31.50	241.50
Airbag pack B - passenger, side and front curtain airbags (only with seat packs B or D)	•	•	•	•	•	•	735.00	110.25	845.25

• Options.  
- Not available.  
s Standard equipment.

† Calculated at 15% on all products.



16" alloy wheels.



Cruise control.



Electric mirrors.



Ladder carrier.



Satellite navigation.



Multi-function steering wheel.

## Crafter chassis and double cab factory options. (continued)

	MWB		LWB				Manufacturer's RRP		
	chassis cab				double cab		Basic retail excluding VAT £ †	VAT £ †	Total retail including VAT £ †
	CR35	CR50	CR35	CR50	CR35	CR50			
<b>Heating and ventilation.</b>									
<b>Air conditioning</b> - 'Climatic', includes temperature display, external <sup>1</sup>	•	•	•	•	•	•	925.00	138.75	1,063.75
<b>Seat packs.</b>									
<b>Seats</b> - 'Box' fabric upholstery (not with seat pack K)	•	•	•	•	•	•	55.00	8.25	63.25
<b>Seats</b> - leatherette upholstery (not with seat pack K)	•	•	•	•	•	•	30.00	4.50	34.50
<b>Seat pack A</b> - driver's seat with lumbar support	•	•	•	•	•	•	60.00	9.00	69.00
<b>Seat pack B</b> - driver and single passenger seat with lumbar support and inner armrest	•	•	•	•	•	•	120.00	18.00	138.00
<b>Seat pack C</b> - driver only with suspension and lumbar support	•	•	•	•	•	•	200.00	30.00	230.00
<b>Seat pack D</b> - driver and single passenger seat with suspension, lumbar support and inner armrest	•	•	•	•	•	•	320.00	48.00	368.00
<b>Seat pack G</b> - heated driver's seat	•	•	•	•	•	•	95.00	14.25	109.25
<b>Seat pack H</b> - heated driver and front passenger seats	•	•	•	•	•	•	190.00	28.50	218.50
<b>Seat pack K</b> - folding single passenger seat (not with airbag packs or seat pack H) <sup>2</sup>	•	•	•	•	-	-	230.00	34.50	264.50
<b>Towbar packs.</b>									
<b>Towbar pack A</b> - preparation, with socket <sup>3</sup>	•	•	•	•	•	•	105.00	15.75	120.75
<b>Towbar pack B</b> - preparation with bracket, socket and cable <sup>3,4</sup>	•	•	•	•	•	•	175.00	26.25	201.25
<b>Towbar pack C</b> (towing weight 2.0t) - fixed ball with 13 pin socket <sup>3,4,5</sup>	•	•	•	•	•	•	295.00	44.25	339.25
<b>Towbar pack D</b> (towing weight 2.0t) - removable ball <sup>3,4,5</sup>	•	•	•	•	•	•	405.00	60.75	465.75
<b>Towbar pack E</b> (towing weight 2.0t) - jaw type with 13 pin socket <sup>3,4,5</sup>	•	•	•	•	•	•	300.00	45.00	345.00

• Options.

- Not available.

s Standard equipment.

† Calculated at 15% on all products.

<sup>1</sup> **Air conditioning:** Alternator uprated to 180A.

<sup>2</sup> **Seat pack K:** Only with standard 'Inca' trim.

<sup>3</sup> **Towbars:** In most circumstances, for commercial use, a tachograph will be required when towing equipment is fitted.

<sup>4</sup> **Towbars:** Only one front towing eye on CR35 models.

<sup>5</sup> **Towbars:** An adaptor is available from Volkswagen Van Centres, to allow connection to twin 7 pin sockets.



Air conditioning 'Climatic'.

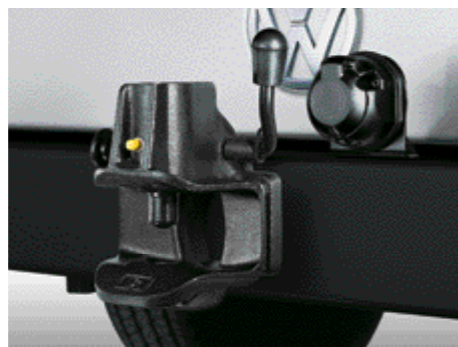

Towbars.



Sliding and tilting sunroof.

## Crafter chassis and double cab dimensions and weights.

### Chassis cab medium wheelbase.

Unbodied.

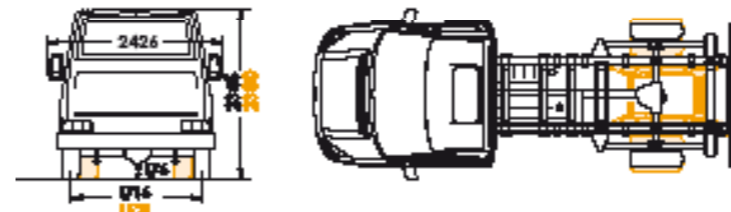
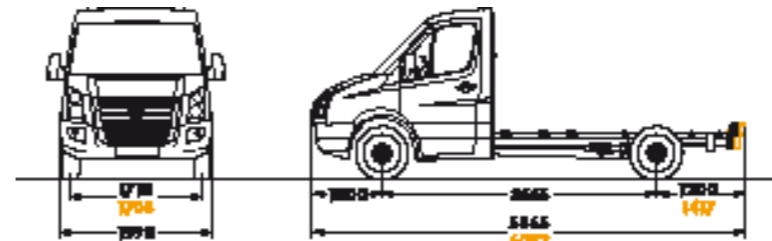

Optional dropside.

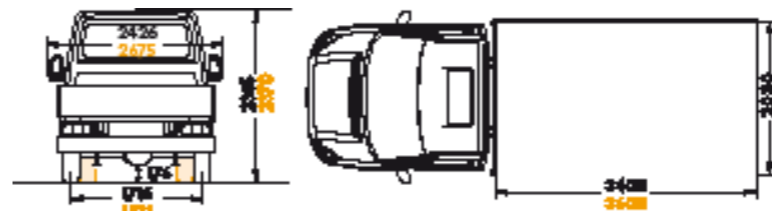

Wheelbase	3,665
Recommended constructional external length	
CR35	3,670
CR50	3,845
Turning circle (wall to wall)	13.5m

Figures in orange indicate CR50 dimensions, where different.

Dimensions in mm unless otherwise indicated.

Wheelbase	3,665
Load area	
CR35	6.9m <sup>2</sup>
CR50	7.7m <sup>2</sup>
Turning circle (wall to wall)	13.5m

Figures in orange indicate CR50 dimensions, where different.

Dimensions in mm unless otherwise indicated.

The height measurements listed in dimensions are based on vehicles with standard specification, and may differ by approx ± 40mm depending on equipment fitted. Please note vehicle drawings are not to scale.

Gross vehicle weight	Axle load limit front / rear	Trailer weight braked / unbraked*	Gross train weight	Unladen weight**	Payload***	
Model kg	kg	kg	kg	kg	kg	
<b>CR35 3,500</b>	88PS BlueTDI	1,650 / 2,250	2,000 / 750	5,500	1,757	<b>1,743</b>
	109PS BlueTDI	1,650 / 2,250	2,000 / 750	5,500	1,757	<b>1,743</b>
	109PS BlueTDI Shiftmatic	1,650 / 2,250	2,000 / 750	5,500	1,755	<b>1,745</b>
	136PS BlueTDI	1,650 / 2,250	2,000 / 750	5,500	1,757	<b>1,743</b>
	163PS BlueTDI	1,650 / 2,250	2,000 / 750	5,500	1,757	<b>1,743</b>
<b>CR50 5,000</b>	109PS BlueTDI	1,850 / 3,500	2,000 / 750	7,000	1,994	<b>3,006</b>
	136PS BlueTDI	1,850 / 3,500	2,000 / 750	7,000	1,994	<b>3,006</b>
	136PS BlueTDI Shiftmatic	1,850 / 3,500	2,000 / 750	7,000	1,992	<b>3,008</b>
	163PS BlueTDI	1,850 / 3,500	3,000 / 750	7,000	1,994	<b>3,006</b>

Roof load limit 100kg. Trailer nose weight 100kg. All data is provisional.

\* For 12% gradient.

\*\* Unladen weight includes full tank of fuel and driver (75kg), excludes crew.

\*\*\* Payload with full tank of fuel and driver (75kg), excluding crew.

Payload = gross vehicle weight - unladen weight.

**Please note:** CR35 models (excluding 88PS engine) have a 'design trailer weight (braked)' of 2,800kg; to increase the 'Gross Train Weight' to 6,300kg it is necessary to fit a towbar that is rated at 2,800kg and amend the vehicle's plating details accordingly. A range of rear axle ratios are available to enable the driveline to be matched to the operational requirements; please contact your nearest Van Centre for full details.

Weights are for vehicles with standard specification. The addition of factory options or Volkswagen Van Centre fitted accessories may affect unladen weight and payload.



# Crafter chassis and double cab dimensions and weights. (continued)

## Chassis cab long wheelbase.

Unbodied.

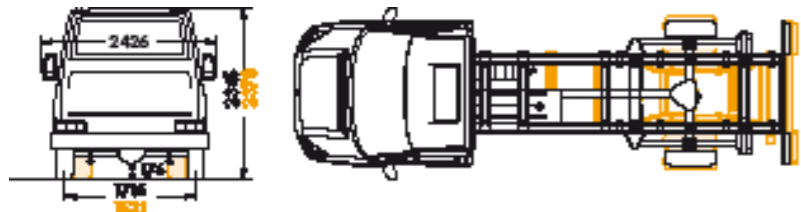
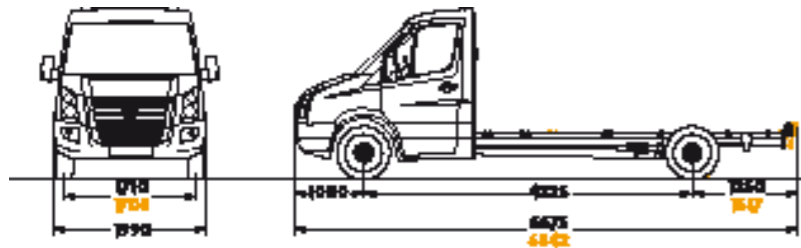

Optional dropside.

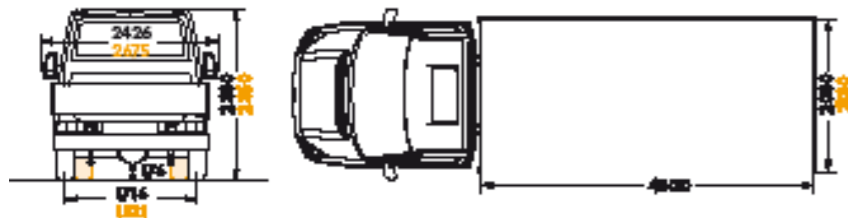
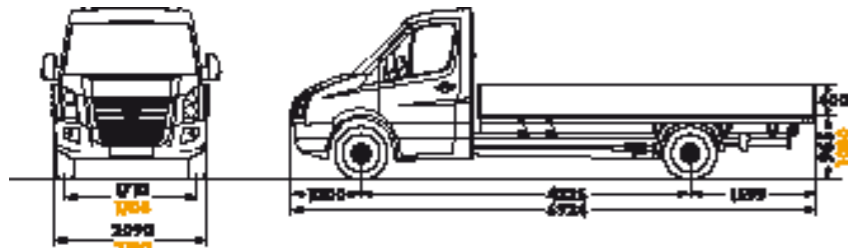

Wheelbase	4,325
Recommended constructional external length	
CR35	4,425
CR50	4,610
Turning circle (wall to wall)	15.6m

Figures in orange indicate CR50 dimensions, where different.  
Dimensions in mm unless otherwise indicated.

Wheelbase	4,325
Load area	
CR35	8.7m <sup>2</sup>
CR50	9.2m <sup>2</sup>
Turning circle (wall to wall)	15.6m

Figures in orange indicate CR50 dimensions, where different.  
Dimensions in mm unless otherwise indicated.

Gross vehicle weight	Engine	Axle load limit front / rear	Trailer weight braked / unbraked*	Gross train weight	Unladen weight**	Payload***
Model kg		kg	kg	kg	kg	kg
<b>CR35 3,500</b>	88PS BlueTDI	1,650 / 2,250	2,000 / 750	5,500	1,785	<b>1,715</b>
	109PS BlueTDI	1,650 / 2,250	2,000 / 750	5,500	1,785	<b>1,715</b>
	109PS BlueTDI Shiftmatic	1,650 / 2,250	2,000 / 750	5,500	1,783	<b>1,717</b>
	136PS BlueTDI	1,650 / 2,250	2,000 / 750	5,500	1,785	<b>1,715</b>
	163PS BlueTDI	1,650 / 2,250	2,000 / 750	5,500	1,785	<b>1,715</b>
<b>CR50 5,000</b>	109PS BlueTDI	1,850 / 3,500	2,000 / 750	7,000	2,032	<b>2,968</b>
	136PS BlueTDI	1,850 / 3,500	2,000 / 750	7,000	2,032	<b>2,968</b>
	136PS BlueTDI Shiftmatic	1,850 / 3,500	2,000 / 750	7,000	2,030	<b>2,970</b>
	163PS BlueTDI	1,850 / 3,500	3,000 / 750	7,000	2,032	<b>2,968</b>

## Double cab long wheelbase.

Unbodied.

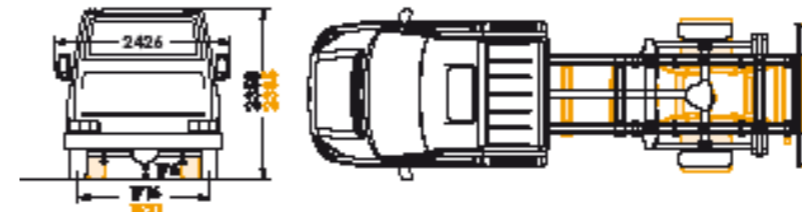
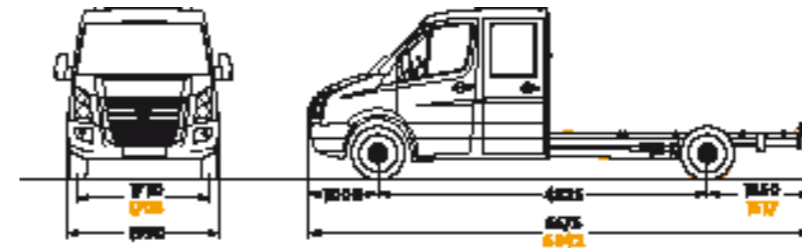

Optional dropside.

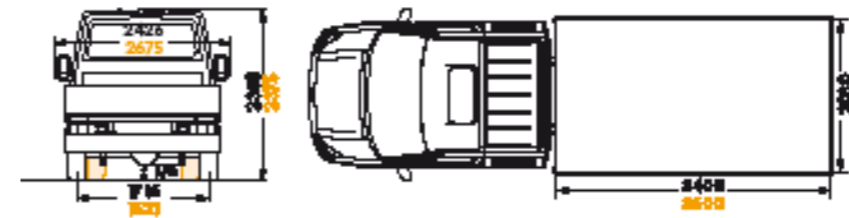
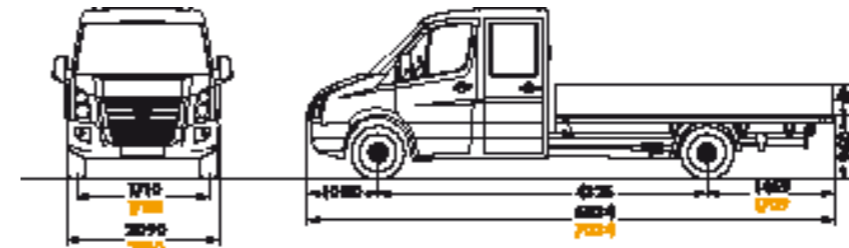

Wheelbase	4,325
Recommended constructional external length	
CR35	3,440
CR50	3,610
Turning circle (wall to wall)	15.6m

Figures in orange indicate CR50 dimensions, where different.  
Dimensions in mm unless otherwise indicated.

Wheelbase	4,325
Load area	
CR35	6.9m <sup>2</sup>
CR50	7.7m <sup>2</sup>
Turning circle (wall to wall)	15.6m

Figures in orange indicate CR50 dimensions, where different.  
Dimensions in mm unless otherwise indicated.

The height measurements listed in dimensions are based on vehicles with standard specification, and may differ by approx ± 40mm depending on equipment fitted. Please note vehicle drawings are not to scale.

Gross vehicle weight	Engine	Axle load limit front / rear	Trailer weight braked / unbraked*	Gross train weight	Unladen weight**	Payload***
Model kg		kg	kg	kg	kg	kg
<b>CR35 3,500</b>	109PS BlueTDI	1,800 / 2,250	2,000 / 750	5,500	2,061	<b>1,439</b>
	109PS BlueTDI Shiftmatic	1,800 / 2,250	2,000 / 750	5,500	2,059	<b>1,441</b>
	136PS BlueTDI	1,800 / 2,250	2,000 / 750	5,500	2,061	<b>1,439</b>
<b>CR50 5,000</b>	109PS BlueTDI	2,000 / 3,500	2,000 / 750	7,000	2,299	<b>2,701</b>
	109PS BlueTDI Shiftmatic	2,000 / 3,500	2,000 / 750	7,000	2,297	<b>2,703</b>
	136PS BlueTDI	2,000 / 3,500	2,000 / 750	7,000	2,299	<b>2,701</b>

Roof load limit 100kg. Trailer nose weight 100kg. All data is provisional.

\* For 12% gradient.

\*\* Unladen weight includes full tank of fuel and driver (75kg), excludes crew.

\*\*\* Payload with full tank of fuel and driver (75kg), excluding crew.

Payload = gross vehicle weight - unladen weight.

Weights are for vehicles with standard specification. The addition of factory options or Volkswagen Van Centre fitted accessories may affect unladen weight and payload.

**Please note:** CR35 models (excluding 88PS engine) have a 'design trailer weight braked' of 2,800kg; to increase the 'Gross Train Weight' to 6,300kg it is necessary to fit a towbar that is rated at 2,800kg and amend the vehicle's plating details accordingly. A range of rear axle ratios are available to enable the driveline to be matched to the operational requirements; please contact your nearest Van Centre for full details.

## VAT information.

The VAT paid on vans can usually be recovered if the vehicle is purchased by a VAT registered business. However VAT incurred on the purchase of vans fitted with windows and/or seats to the rear of the driver cannot be recovered unless the vehicle payload meets or exceeds 1,000kg. Otherwise VAT incurred on these vehicles is not available for recovery unless the vehicle is used for 100% business purposes. It is the customer's responsibility to deal with the VAT correctly. Customers should always seek professional advice to establish their own personal tax position.

## Crafter chassis and double cab engine specifications.

BlueTDI diesel engines with AdBlue® technology.				
	88PS BlueTDI	109PS BlueTDI	136PS BlueTDI	163PS BlueTDI
Mixture preparation/injection method	Common-rail direct injection			
Exhaust emission standard	EURO V and EEV†			
No. of cylinders	5			
Cubic capacity, cm³	2,461			
Output, PS at rpm	88 at 3,300	109 at 3,300	136 at 3,500	163 at 3,500
Torque, max. Nm/rpm	250/1,900-2,300	300/1,900-2,300	330/2,000	360/2,200
Diesel particulate filter	•	•	•	•
6-speed manual gearbox	•	•	•	•
6-speed Shiftmatic gearbox	-	•	•	-
Rear wheel drive	•	•	•	•

### Electrics.

Alternator	110A		
Battery	- CR30 and CR35	72Ah (380A)	
	- CR50	100Ah (450A)	

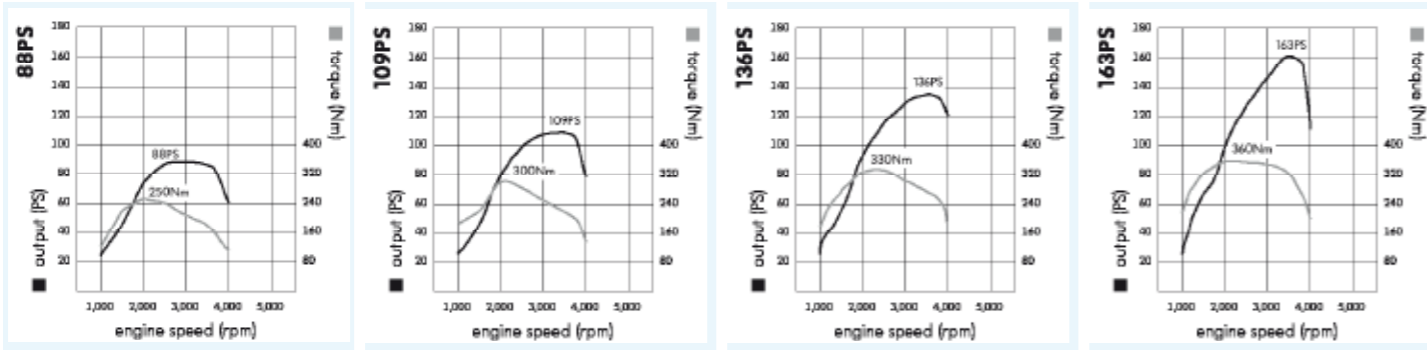

- Available
- Not available
- † Enhanced Environmentally Friendly Vehicle – the emission measure below the maximum limit for EURO V standards.

## Shiftmatic.

This lightweight gearbox combines the functionality of an automatic with the characteristics of a manual.

The Shiftmatic can be operated in either manual or automatic mode. In automatic mode all gears are selected automatically by the gearbox control unit, with a kick-down function for those times where extra acceleration is needed.

In manual mode, the driver pushes the gear lever forwards to change down, or backwards to change up, giving all the benefits of a manual gearbox without the need for a manual clutch – perfect for city driving.



## Chassis and double cab fuel consumption and performance.

Model	Engine	Urban <sup>1</sup> mpg (l/100km)	Extra urban <sup>1</sup> mpg (l/100km)	Combined <sup>1</sup> mpg (l/100km)	Top speed (where the law permits) mph	
<b>Chassis cab with optional dropside. (medium wheelbase and long wheelbase)</b>						
<b>CR35</b>	88PS BlueTDI	2.5 litre	20.6 (13.7)	32.1 (8.8)	26.6 (10.6)	78
	109PS BlueTDI	2.5 litre	22.6 (12.5)	33.6 (8.4)	28.5 (9.9)	84
	109PS BlueTDI Shiftmatic	2.5 litre	26.6 (10.6)	32.5 (8.7)	30.1 (9.4)	86
	136PS BlueTDI	2.5 litre	21.7 (13.0)	32.8 (8.6)	27.7 (10.2)	87
	163PS BlueTDI	2.5 litre	23.0 (12.3)	33.6 (8.4)	28.8 (9.8)	93
<b>CR50</b>	109PS BlueTDI	2.5 litre	TBA	TBA	TBA	56 (78)
	136PS BlueTDI	2.5 litre	TBA	TBA	TBA	56 (80)
	136PS BlueTDI Shiftmatic	2.5 litre	TBA	TBA	TBA	56 (81)
	163PS BlueTDI	2.5 litre	TBA	TBA	TBA	56 (87)
<b>Double cab with optional dropside. (long wheelbase)</b>						
<b>CR35</b>	109PS BlueTDI	2.5 litre	22.6 (12.5)	33.6 (8.4)	28.5 (9.9)	84
	109PS BlueTDI Shiftmatic	2.5 litre	27.2 (10.4)	32.1 (8.8)	30.1 (9.4)	86
	136PS BlueTDI	2.5 litre	21.7 (13.0)	32.8 (8.6)	27.7 (10.2)	87
<b>CR50</b>	109PS BlueTDI	2.5 litre	TBA	TBA	TBA	56 (78)
	109PS BlueTDI Shiftmatic	2.5 litre	TBA	TBA	TBA	56 (77)
	136PS BlueTDI	2.5 litre	TBA	TBA	TBA	56 (80)











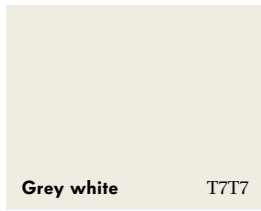



<sup>1</sup> With 50% payload.

Some figures are provisional.  
The figures listed apply to vehicles with manual gearbox, without optional extras.  
Figures in brackets show top speed for vehicles without speed limiter.

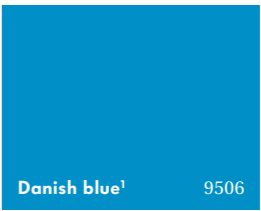

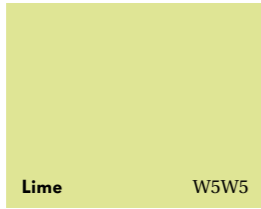
# Paint colours and upholstery.

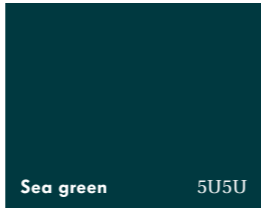
## Solid paint.

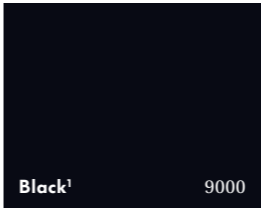



 Grey white T7T7	 Spectral yellow IXIX	 Bright orange E3E3	 Tornado red G2G2	 Paprika red H7H7	 Spanish red H9H9	 Steel blue B6B6	 Indian blue F3F3	 Danish blue <sup>1</sup> 9506	 Flannel grey B9B9
 Stone blue <sup>1</sup> 9544	 Lime W5W5	 Friesen green X8X8	 Sea green 5U5U	 Deep black <sup>1</sup> 3902	 Black <sup>1</sup> 9000				

## Metallic paint<sup>1</sup>

 Shadow blue P6P6	 Raven blue 5Z5Z	 Pine green 9Y9Y	 Off-road grey M3M3	 Fresco green 3P3P	 Wheat beige D1D1	 Oxide silver Q5Q5	 Reflex silver 8E8E
---	---	---	---	---	--	---	--









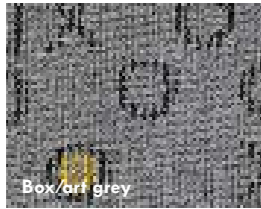

## Pearl effect paint<sup>1</sup>

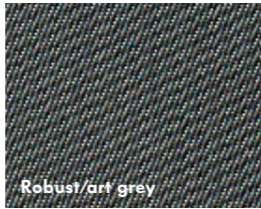
 Berry red 9W9W	 Tibet red 9E9E	 Mistral blue 2E2E	 Night black G6G6	 Diamond black Z4Z4
--	---	--	--	---

-  Available on Transporter.
-  Available on Crafter.
-  Available on Transporter at extra cost.
-  Available on Crafter at extra cost.

**Please note:** Print processes do not allow exact reproduction of the paint and upholstery colours.  
<sup>1</sup> These colours are available at extra cost.  
<sup>2</sup> Box/art grey cloth is only available on Transporter models as part of the optional cab comfort pack.

## Upholstery.

 Inca/art grey	 Box/art grey	 Rhombus/art grey leatherette	 Robust/art grey
  CS BY	  DN <sup>2</sup> CV	  NE MC	 CU

## Accessories.

Our comprehensive range of Volkswagen Commercial Vehicle accessories is constantly evolving to ensure that we can satisfy your every need.

Whether you are looking to increase the flexibility of your vehicle or opting for an aesthetic enhancement, our vast array of accessory products coupled with our dedicated network of Van Centres will help you individualise an already well appointed vehicle.

For the full range of commercial vehicle products and latest additions to the accessories range, visit our website [www.volkswagen-vans.co.uk/accessories](http://www.volkswagen-vans.co.uk/accessories) or pick up a commercial vehicles accessory brochure from your nearest Van Centre.

Our Volkswagen approved accessories come with a **standard 3 years warranty** when purchased with a new vehicle or **2 years warranty** if you purchase an accessory after taking delivery of your vehicle.

### Media.



### Styling.



### Security.

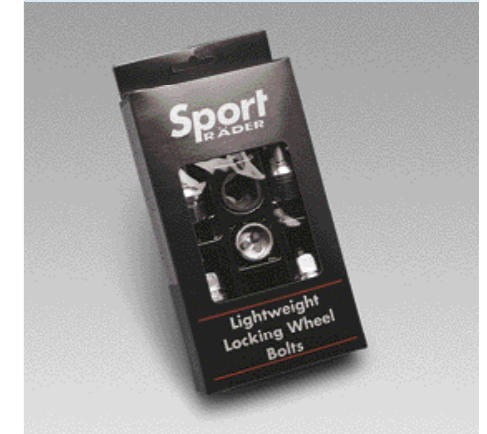

### Protection.

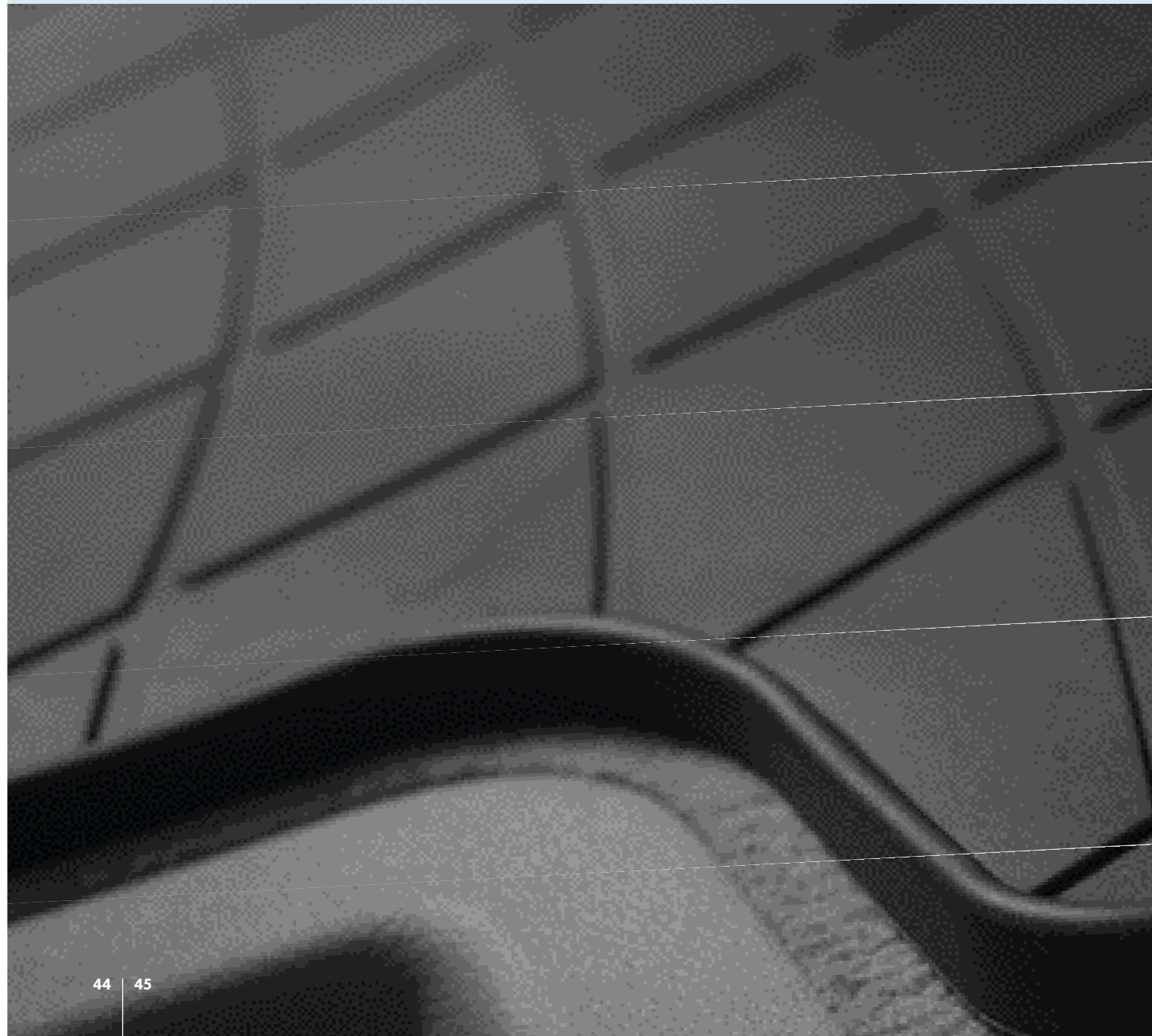

### Van care.



### Protection.

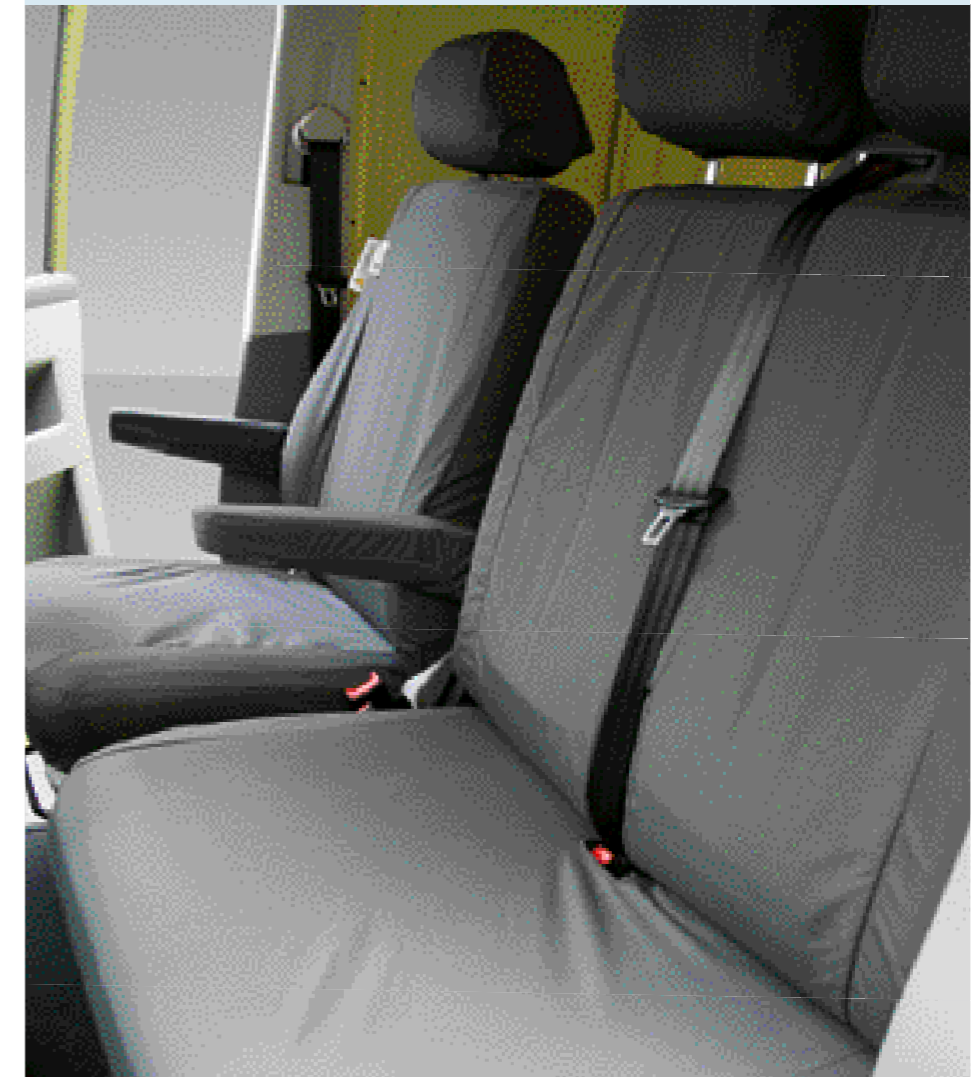

### Towing.









## Glossary.

### **ABS** Anti-lock Braking System.

It can be very challenging to stop a van quickly on a slippery road. ABS helps take a lot of the effort and stress out of a situation. In fact, even an average driver can stop more effectively with ABS than a professional driver without.

The theory is simple, a wheel that's skidding has less traction than a wheel that is not. For example, if you try to pull away too quickly on ice your wheels spin, meaning no traction. Simply, ABS prevents the wheels from skidding whilst you slow down, which means you slow faster and are able to steer while you come to a stop.

### **EDL** Electronic Differential Lock.

Electronic Differential Lock uses the ABS sensors at driven wheels to determine if one of the wheels is spinning faster than the others. It uses the ABS system to momentarily apply braking to balance out the traction to the driven wheels. Front wheel drive vehicles typically have the most recognisable feel, as they make the typical ABS type pulsating sound when activated during wheel spin.

### **ESP** Electronic Stabilisation Programme.

When the vehicle is driving in situations close to its limit ESP makes it easier to control, providing greater directional stability. By applying the brakes on individual wheels it generates forces that help to keep the vehicle moving in the right direction. The system is permanently active and utilises the ABS, EBD, EDL and TCS safety systems. However, the system cannot override the physical limits of the vehicle. If the driver pushes the vehicle beyond its limits ESP will not prevent an accident. On Crafter models, the ESP sensor takes into account any load on board and adjusts its response accordingly.

### **ARP** Active Rollover Protection.

As part of the ESP system, ARP recognises an impending rollover and rapidly applies braking to selective wheels to resist the occurrence of rollover. Especially useful on a vehicle with a high centre of gravity such as a van. ARP detects excessive lateral force, for example driving too fast into a corner, which may result in a rollover.

### **TCS** Traction Control System.

Traction control helps limit tyre slip on slippery surfaces while accelerating, thus helping the driver have greater control. Using sensors at each wheel, the system recognises when traction has been lost and it momentarily applies braking to that wheel to regain the traction.

Traction control does not have the ability to increase traction; it just attempts to prevent a vehicle's wheels from spinning. In some vehicles, TCS is also known as ASR.

### **EBA** Electronic Brake Assist.

The Electronic Brake Assist system helps to shorten stopping distances, especially when fully laden. In an emergency when full brake pressure is required, a sensor recognises this and uses a hydraulic booster to aid the driver.

### **EBD** Electronic Brakeforce Distribution.

EBD helps prevent the rear-end from breaking away under heavy braking by ensuring maximum braking performance at both the front and rear wheels. Brake 'fading', as a result of overheating, is also counteracted.

### **DPF** Diesel Particulate Filter.

A diesel particulate filter is a system for removing particulates from diesel exhausts and is a major step forward in the reduction of particulate contaminants in the environment.

### **Engine Braking Control.**

This system prevents the driven wheels from locking due to the engine braking effect when the accelerator pedal is released suddenly or when the vehicle is braked with a gear engaged.

### **Passive safety.**

Passive safety refers measures that help protect the occupants against injury or help reduce injury severity in the event of an accident. Passive safety measures include the safety belt system, the airbags\*, the rigid occupant cell and the crumple zones at the front of the vehicle. Safety features built-in to the body, front and rear, help dissipate most of the impact energy. All help provide excellent all-around protection.



## Dedicated Van Centre network.



Our network of Van Centres is spread throughout the UK, and forms the backbone of everything we do for you. Week in, week out, our Van Centres provide vital technical support and practical backup for everything that relates to Volkswagen vans. This reservoir of knowledge and array of technical ability is there for you when you need it.

We're constantly improving and extending our range of services, and improving opening hours to meet

your needs. After all, you need your vehicle serviced at the most convenient time, and we understand that down time equals lost income.

And don't forget, having read through this brochure, if you still aren't sure which vehicle is the right one, then your nearest Van Centre staff will be pleased to help.

[www.vw-vancentres.co.uk](http://www.vw-vancentres.co.uk)



# Chassis and double cabs

May 2009

This brochure supersedes all previous publications.  
CVW229CAB

[www.volkswagen-vans.co.uk](http://www.volkswagen-vans.co.uk)