

# E-Class Coupé and Cabriolet

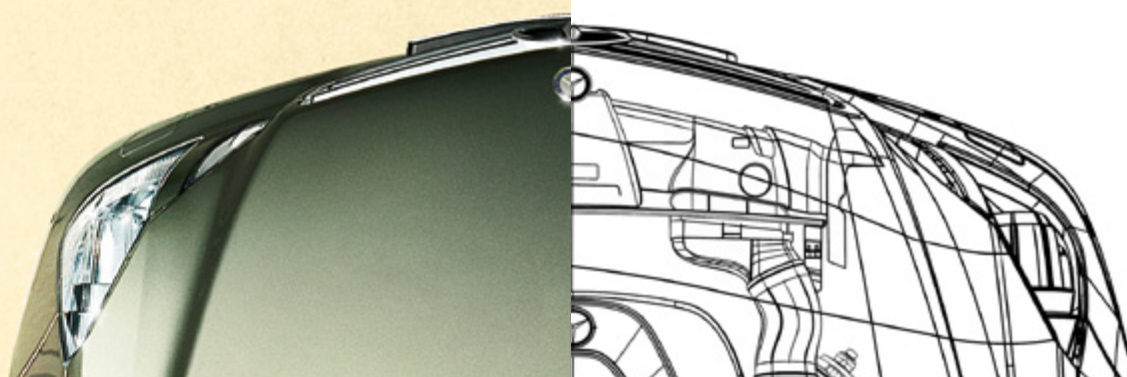

Mercedes-Benz





# The E-Class Coupé and Cabriolet

## First impressions

**Coupé.** Sit back and admire those sleek, striking lines. Picture yourself behind the wheel, enjoying the comfortable and beautifully designed cabin. Imagine yourself revelling in the effortless power and outstanding agility, reassured by the presence of advanced safety technology. And ask yourself: is there a finer way to travel than by Mercedes-Benz coupé?

[Overview](#) | [from page 3](#)   [Insights](#) | [page 11](#)

**Cabriolet.** The E-Class Cabriolet offers beautifully refined open-top motoring for four. Its stylish and aerodynamic exterior helps to minimise wind noise and maximise fuel efficiency, while, under the skin, advanced engineering ensures an effortless and stimulating drive.

[Overview](#) | [from page 12](#)   [Insights](#) | [page 19](#)

## Facts

**Endless enjoyment:** Engines and suspension [from page 22](#)

**Protective instincts:** Safety [from page 29](#)

**Relaxed driving:** Comfort [from page 34](#)

**True individuality:** Equipment [from page 44](#)

**More Mercedes-Benz:** Services [from page 62](#)

**The E-Class Coupé and Cabriolet:** Technical data [from page 65](#)



# Magnetic

## The attraction is physical

Heads turn whenever it takes  
to the road. Cursory glances  
become longing stares.  
Admiration mingles with envy.  
It's the new E-Class Coupé.



# Athletic

## Power meets self-control

It has an engine that delivers efficient power, and a transmission that always knows the right gear. A suspension that smooths the road, and brakes that simplify hill starts. Now all it needs is you. → pages 24–28



E 350 CGI BlueEFFICIENCY: direct petrol injection, Agility Control suspension, Adaptive Brake System with hold function





You're in charge. The multi-function steering wheel puts everything at your fingertips, Linguatronic voice control leaves your hands free for the driving. → page 34

Optional COMAND multimedia system with Linguatronic voice control



# Muscular

Honed for performance



The E-Class Coupé Sport

The body is lithe and athletic, the steering direct and precise.  
Sport is in its genes. → pages 48–53









# Responsive

Sport on demand





Sport mode on, apex approaching fast. The suspension feels tauter, the reactions faster. Bends were made for this.

Dynamic Handling Package with sport mode available as an option (standard on E500)



## A calm ride, however rough the surface

Roads, like seas, are never entirely smooth. But whereas ships benefit from breakwaters that create a calmer surface, cars have to take the tarmac as it comes – potholes, ruts, ridges and all. That's why the Agility Control suspension includes our Selective Damping System. It adjusts the damper settings to suit the road surface, enabling imperfections to be absorbed more effectively, and those on board to travel more comfortably.

If the optional Dynamic Handling Package with sport mode is fitted, firmer damper settings can also be selected manually – by simply pressing the 'sport' button in the centre console.



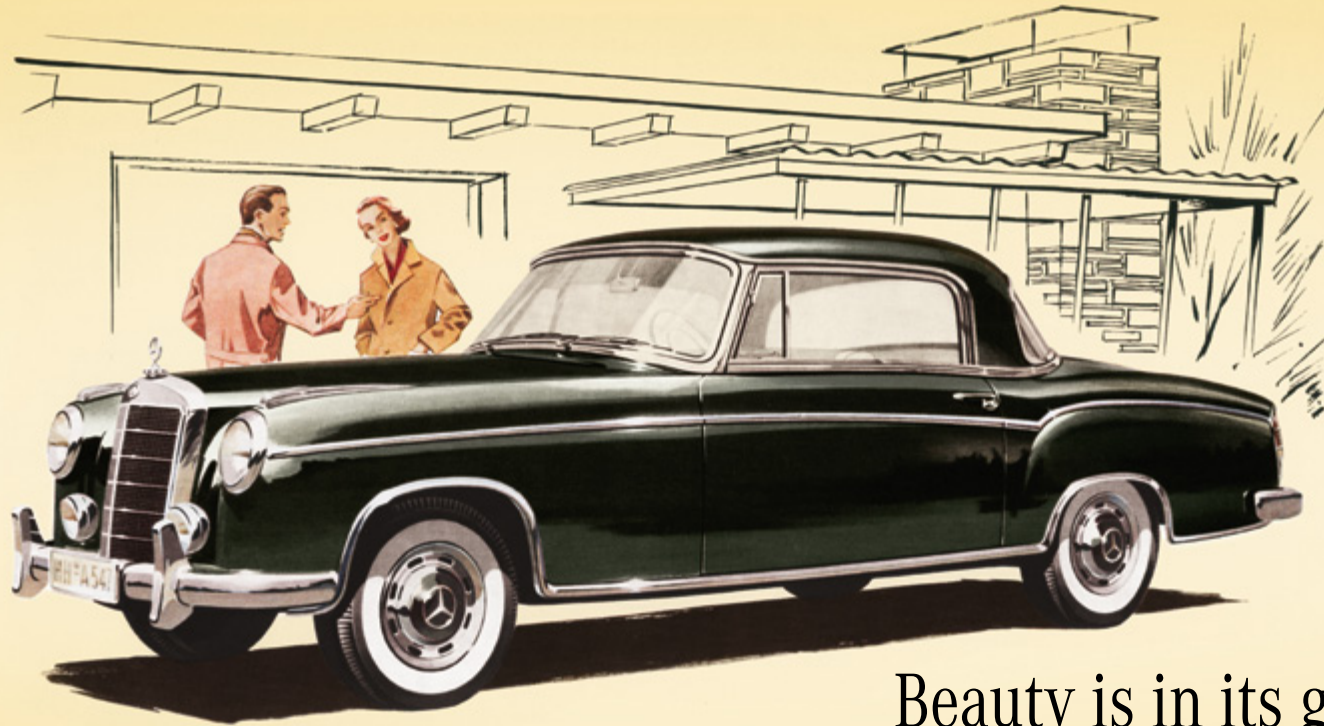

## Beauty is in its genes

Good looks often run in the family – and the E-Class Coupé and Cabriolet illustrate this perfectly. Their exceptionally handsome line stretches back to the 220S Coupé of 1956, a car whose elegant style and innovative technology made it a milestone in motoring history, and provided the template for all Mercedes-Benz coupés to come.

One of the original grand tourers, the 220S Coupé was built for luxurious long-distance travel. As the German magazine Motor Revue put it in 1958: “The 220S offers abundant comfort and performance. The interior appointments can only be described as outstanding”. Were the journalist to review today’s E-Class

Coupé or E-Class Cabriolet, he might well say the same.

Each has all the makings of a modern classic: advanced technology, impressive comfort, and the peerless elegance that sets every Mercedes-Benz coupé and cabriolet apart.



## How to enjoy modern open-top motoring – yet stay true to a great tradition

The arrow-like front end sets a distinctive tone, the rising waist line and muscular rear combine to elegant and athletic effect. A classic soft-top adds the finishing touch – the perfect blend of technology and tradition.



# How to make journeys feel smoother – and summers seem longer

The aerodynamic shape cuts through the air; the Airscarf heating system keeps chills at bay. Agile handling and intelligent safety systems make for a stirring and yet reassuring drive.





# How to feel the wind in your hair...

The unique new Aircap system directs the flow of air over and away from the cabin, meaning all four occupants enjoy a calm, comfortable and relaxing ride, even with the roof down. → page 36





Yet remain thoroughly unruffled



# Why the E-Class Cabriolet stays with you – even after you've arrived

It's an experience that lingers long in the mind. But is it the exceptional open-top comfort that makes it so memorable? Or the effortlessness with which it covers ground? Either way, you'll find the next journey can never come soon enough.



# Why advanced aerodynamics makes for happier passengers

When you see a soap bubble floating by, your first thoughts are probably not of surface tension or light interference. Instead, you'll be admiring its iridescent colours and marveling at its almost ethereal lightness. Similarly, when travelling in a beautiful cabriolet, you're unlikely to concern yourself with complex issues such as air flow speeds, pressure levels and secondary circulation.

Our engineers, on the other hand, have been giving these matters a great deal of thought. The result is the E-Class Cabriolet's innovative Aircap system, an ingenious combination of front wind deflector and special rear draught-stop that directs the flow of air away from the occupants. They might not perhaps appreciate the aerodynamic principles behind it, but they can't fail to feel the benefit: a remarkably calm open-top experience – even for those in the rear.



22 **BlueEFFICIENCY**24 **Diesel engines**

4-cylinder

6-cylinder

25 **Petrol engines**

4-cylinder

6-cylinder

8-cylinder

26 **Exhaust systems**27 **Transmissions**

6-speed manual transmission

5-speed automatic transmission

7G-Tronic automatic transmission

28 **Suspension**

Agility Control suspension

Agility Control sports suspension

Dynamic Handling Package

Adaptive Brake System

29 **Safer driving**

Attention Assist

Intelligent Light System

DISTRONIC Plus

LED tail lights

Adaptive brake lights

31 **Occupant and pedestrian protection**

Pre-Safe® system

Pre-Safe® Brake

Neck-pro head restraints

Active Bonnet

Airbags

32 **Cabriolet safety**

High-strength bodyshell

Roll-over protection

34 **Audio and navigation**

Central display unit and controller

COMAND multimedia system

Surround sound system

35 **Electronic assistants**

Parktronic with Advanced Parking Guidance

Reversing camera

36 **Open-top comfort**

Aircap

Airscarf

Aerodynamics

38 **Soft-top and boot space**

Fully electric soft-top

40 **Climate control systems**

Automatic climate control

Luxury automatic climate control

42 **Seats**

Automatic seat belt hand-over

Easy-Entry system

Sculpted rear seats

## E-Class Coupé and Cabriolet in detail



**44 Lines, upholstery and trim**

SE

Sport

**54 *designo*****56 Standard equipment****57 Optional extras****58 Alloy wheels**

Standard wheels

Optional wheels

AMG wheels

incenio design wheels

**60 Retailer-fit accessories****62 Services**

Roadside Assistance

Mercedes-Benz Finance and Insurance

Test drive

Interactive Owner's Manuals

Finance offers

**66 Technical data**

Technical data for Coupé

Technical data for Cabriolet

**68 Dimensions**

Dimensions for Coupé

Dimensions for Cabriolet

**69 Paint finishes**

# BlueEFFICIENCY – technology for more efficient driving



As the inventor of the motor car, we feel we have a special responsibility for improving its resource efficiency – without compromising on safety, comfort and driving pleasure.

Our comprehensive BlueEFFICIENCY measures have already brought significant cuts in fuel consumption to many current Mercedes-Benz models, helping to lower both their CO<sub>2</sub> emissions and their running costs. What's more, we are continuing to develop new environmentally friendly technologies that will reduce emissions even further and help to make motoring more sustainable in the long term.

**BlueEFFICIENCY – the Mercedes-Benz efficiency drive.** In addition to highly advanced and efficient engines, BlueEFFICIENCY models come with a range of energy-saving measures that enable fuel consumption and CO<sub>2</sub> emissions to be reduced by up to 23%. These measures vary from model to model but can include ECO start/stop, on-demand ancillary components and low-resistance tyres, as well as aerodynamic optimisation and the use of lightweight materials.

**BlueTEC – cleaner diesel power.** BlueTEC is our cleanest diesel technology to date. Its combination of advanced common-rail direct injection, optimised combustion and modular emissions control systems reduces particulate levels by up to 95% and removes up to 90% of nitrogen oxides, leaving little but water, harmless nitrogen and the satisfaction of knowing you've done your bit for the environment.

**HYBRID and BlueTEC HYBRID – the future of internal combustion.** The next stage in our efficiency drive, hybrid drivetrains will bring new levels of fuel efficiency and emissions reduction to tomorrow's Mercedes-Benz passenger cars. The petrol/electric **HYBRID** system allies an economical internal combustion engine to an electric motor that not only assists the engine when accelerating but also recovers kinetic energy during braking. In addition, the system automatically shuts off the engine as the car slows to a standstill, helping to reduce fuel consumption even further.



BlueEFFICIENCY measures substantially reduce fuel consumption and CO<sub>2</sub> emissions





The diesel equivalent, **BlueTEC HYBRID**, combines the benefits of hybrid drive with the clean-burn technology of BlueTEC. It achieves outstanding fuel economy while keeping harmful emissions to a minimum.

#### **BlueZERO – the drivetrains of tomorrow.**

The BlueZERO concept showcases three highly developed electric vehicle variants. The E-CELL is an all-electric system driven solely by the battery, E-CELL PLUS pairs battery power with a range-extending internal combustion engine, while the F-CELL features a hydrogen-based fuel-cell stack.



The HYBRID system lowers fuel consumption by up to 20%

**Design for Environment.** Our environmental philosophy is not just about in-car technologies. It also involves taking the entire lifecycle of each vehicle into account, from its initial planning to its end-of-life recycling. We apply the same approach to the building and maintenance of new factories too, saving energy, avoiding harmful emissions and making increasing use of renewable resources. In addition, Mercedes-Benz is involved in the development of alternative fuels and conducts research in the field of bionics.

For more information about what BlueEFFICIENCY can do for you, please visit [www.mercedes-benz.co.uk/blueefficiency](http://www.mercedes-benz.co.uk/blueefficiency)



## Diesel engines

The E-Class Coupé and Cabriolet are available with our latest-generation diesel engines. They are fitted with particulate filters as standard, meet the strict EU5 emissions standard and are even more efficient, powerful and refined than their predecessors.



The twin-turbo E 220 CDI BlueEFFICIENCY features common-rail diesel technology

**4-cylinder diesel engines.** The E-Class Coupé and Cabriolet offer a choice of two refined, economical and responsive 4-cylinder diesel models. The E 220 CDI BlueEFFICIENCY delivers 170 hp and 400 Nm of torque, while the E 250 CDI BlueEFFICIENCY offers 204 hp and has 500 Nm of torque available from just 1,600 rpm. Despite boasting up to 15% more power than comparable previous-generation models and up to 20% more torque, they also achieve reductions in fuel consumption and CO<sub>2</sub> emissions of up to 18%.

The key to this highly efficient performance is our fourth-generation common-rail system. It allows fuel to be injected at even higher pressures – up to 2,000 bar – and works in conjunction with

the ultra-precise piezo injectors, optimised combustion chambers and twin turbochargers to maximise performance and efficiency across the rev range. Thanks to counter-rotating balancer shafts, both 4-cylinder diesel engines also remain smooth and refined at all speeds.

**6-cylinder diesel engine.** With an output of 231 hp, plus 540 Nm of torque from 1,600 to 2,400 rpm, the E 350 CDI BlueEFFICIENCY offers even deeper reserves of power. It also achieves impressively low fuel consumption and emissions, thanks to the weight-saving construction of its V6 engine, precise piezo-electric technology and injection pressures of up to 1,600 bar.





## Petrol engines

The petrol engines for the E-Class Coupé and Cabriolet prove you can reduce environmental impact and still enjoy your driving. They are powerful and responsive, yet also fuel-efficient and low on CO<sub>2</sub> emissions.



The 4-cylinder petrol engine features high-pressure piezo-electric direct injection

### 4-cylinder direct-injection petrol engines.

The E 200 CGI BlueEFFICIENCY and E 250 CGI BlueEFFICIENCY are each powered by a turbocharged 4-cylinder engine with direct petrol injection. Despite their modest 1.8-litre

displacement, they deliver highly impressive levels of power and torque, while remaining utterly refined at all engine speeds. CGI technology is more efficient than conventional fuel injection, and the engine's weight-saving small size and reduced internal friction help to further reduce fuel consumption. The 4-cylinder direct-injection petrol engines offer the following outputs:

- E 200 CGI BlueEFFICIENCY: 184 hp (135 kW) with 270 Nm
- E 250 CGI BlueEFFICIENCY: 204 hp (150 kW) with 310 Nm

**V6 petrol engine.** The highly refined 6-cylinder E 350 CGI BlueEFFICIENCY benefits from a range of advanced engine technologies, including four valves per cylinder, variable camshaft

control for both intake and exhaust, a two-stage intake manifold and balancer shafts. In addition, it features second-generation direct petrol injection with piezo-electric technology and spray-guided combustion. The result is an output of 292 hp (215 kW) and 365 Nm of torque from 3,000 to 5,100 rpm, plus reduced fuel consumption and emissions.

**V8 petrol engine.** The most powerful model in the E-Class Coupé and Cabriolet range is the 8-cylinder E 500. With an output of 387 hp (285 kW) and maximum torque of 530 Nm from 2,800 to 4,800 rpm, it delivers sports-car performance, accelerating from 0 to 62 mph in 5.2 (Coupé) or 5.3 seconds (Cabriolet) and, where permissible, hitting an electronically governed top speed of 155 mph.



## Exhaust systems

The exhaust systems for the E-Class Coupé and Cabriolet are tailored to the needs of each engine, and fitted with eye-catching single or twin tailpipes.

Three different tailpipe designs are offered on the E-Class Coupé and Cabriolet. Four-cylinder models come with a single oval tailpipe, V6



4-cylinder model with single oval tailpipe

models feature twin oval tailpipes, and the E 500 has striking trapezoidal twin tailpipes integrated into the rear diffuser.



V6 model with twin oval tailpipes

Catalytic converters are, of course, fitted as standard on all petrol models, with particulate filters as standard on the diesels.



E 500 with trapezoidal twin tailpipes



## Transmissions

Manual or automatic, the transmissions for the E-Class Coupé and Cabriolet ensure power is always transferred smoothly and rapidly to the wheels.

**4-cylinder models.** The E 220 CDI, E 250 CDI and E 200 CGI BlueEFFICIENCY come with a 6-speed manual transmission that offers fast gear changes with short, accurate throws.

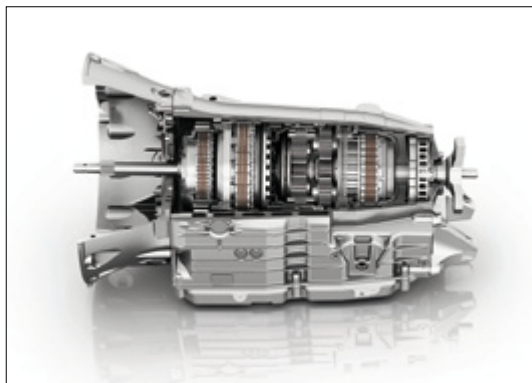

7G-Tronic can skip gears in downshifts for more rapid acceleration

In addition, the engine, gearing and drive ratio are all carefully matched to ensure optimum driving pleasure and comfort. For the petrol-engined E 250 CGI BlueEFFICIENCY, there's a 5-speed automatic transmission as standard (optional on the E 220 CDI, E 250 CDI and E 200 CGI BlueEFFICIENCY). It offers a choice between economy and sport modes, and can also be operated manually by pushing the shift lever to the left or right.

**6- and 8-cylinder models.** V6 and V8 models come with 7G-Tronic automatic transmission. Its seven forward gears ensure the engine is always operating at the ideal speed, helping to reduce fuel consumption. It's also able to change down more than one gear at a time, making for faster overtaking manoeuvres, and comes with manually selectable economy and sport modes.



# Suspension

The E-Class Coupé and Cabriolet are built to give you both agile handling and a relaxing ride. With the Dynamic Handling Package, they also enable you to select a sportier set-up at the touch of a button.

## Agility Control suspension (standard).

The Agility Control suspension includes our Selective Damping System. It adapts automatically to the road and your driving style, increasing damping levels over rougher surfaces, and reducing them for smoother surfaces.

**Agility Control sports suspension with parameter steering** (standard on all V6 and Sport models). The sports version of the Agility Control suspension features firmer springing and damping for reduced body roll and greater stability, especially when pressing on. It's complemented by the more direct parameter steering, which provides even faster responses to your steering inputs.

## Dynamic Handling Package with sport mode

(optional on Sport; standard on E 500 Sport). With the Dynamic Handling Package, you can enhance your driving pleasure at the touch of a button. Simply activate sport mode and the car will instantly switch to sportier settings, giving you firmer damping, faster throttle responses and, on automatic models, a more aggressive shift pattern for optimum acceleration.

## Adaptive Brake System (standard).

In conjunction with anti-lock braking, the Adaptive Brake System ensures optimum braking performance in all situations. It also includes automatic brake drying and priming for faster reactions to the pedal, plus a hold function, activated by pressing the pedal twice, which prevents the car from rolling backwards during hill starts.

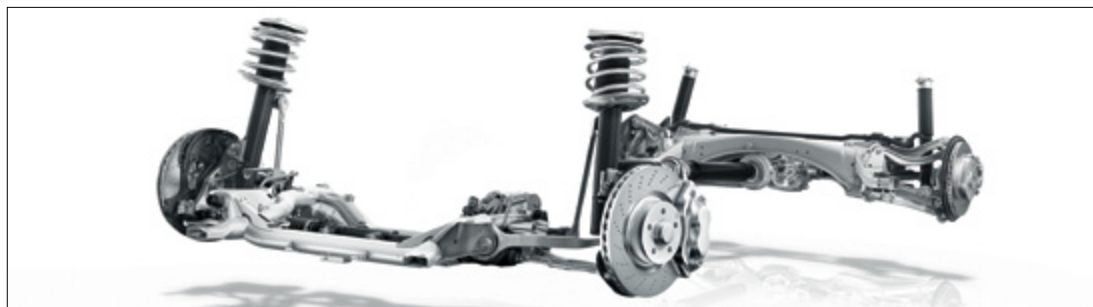

The Dynamic Handling Package with sport mode gives you firmer suspension settings at the touch of a button – for increased agility, optimum control and enhanced high-speed stability



## Safer driving

At Mercedes-Benz, all our safety technology is developed with our vision of accident-free driving in mind. On the E-Class Coupé and Cabriolet, the many electronic driving aids help you to avoid dangerous situations and thus reduce the likelihood of a collision.

**Attention Assist** (standard). Particularly beneficial on long journeys, Attention Assist is a new system for detecting fatigue or inattentiveness. Between speeds of approximately 50 and 110 mph it monitors the driver's behaviour via an array of sensors, and registers unexpected changes that may indicate tiredness or lapses in attention. If it detects such a change, it alerts the driver and recommends taking a break.



If it detects signs of fatigue or inattentiveness, Attention Assist suggests taking a break

**Intelligent Light System** (standard on Sport; optional on SE as part of the Light Package). With its range of automatic headlamp settings, the Intelligent Light System ensures safer night driving on all kinds of roads. Country road mode illuminates the sides of the road more effectively than a conventional headlamp system, for instance, while motorway mode ensures the entire carriageway is evenly lit. In fog mode, the left-hand bi-xenon headlamp swivels outwards

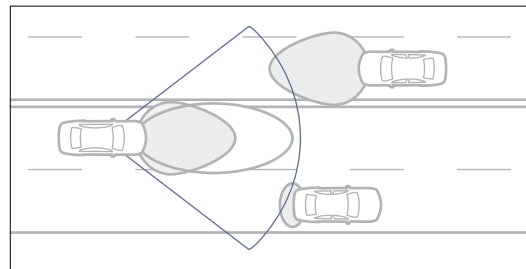

With Adaptive High Beam Assist, the transition between main beam and dipped is almost imperceptible

to improve visibility. Also included is the Active Light System, which enables the headlamps to follow your steering inputs, and Adaptive High Beam Assist, which dips the headlamps only as far as necessary to avoid dazzling other drivers.

**Distronic Plus** (optional). This radar-assisted cruise control system helps you to maintain a safe distance from the vehicle in front. It applies the brakes automatically, bringing the car to a

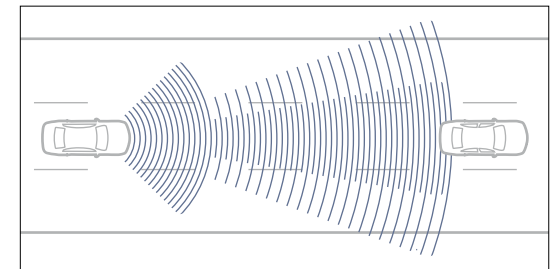

In heavy traffic, Distronic Plus maintains your distance from the vehicle in front and brings the car to a standstill if necessary



standstill if necessary, and accelerates again once the situation allows. DISTRONIC Plus works at between 0 and approximately 125 mph and has a radar range of 0.2 to 200 metres, making it a useful feature in both stop-start and high-speed driving.

**LED tail lights with adaptive brake lights** (standard). The E-Class Coupé and Cabriolet feature LED lamps both for the tail lights and the high-level third brake light. They activate faster than conventional bulbs and also emphasise the sporty looks. In addition, the adaptive brake lights flash during emergency braking to alert those behind to the danger.



Fast-acting LEDs and adaptive brake lights increase safety for you and other drivers



## Occupant and pedestrian protection

The E-Class Coupé and Cabriolet not only offer comprehensive impact protection for all occupants – they also come with a system that can detect an imminent accident and implement a range of anticipatory measures.

**Pre-Safe® system** (standard). If a probable impact is detected, the Pre-Safe® system can take anticipatory measures to protect the occupants, such as activating the reversible seat belt tensioners, moving the front passenger seat to a better position (if fitted with memory seats) and automatically closing the windows and sunroof.

**Pre-Safe® Brake** (optional, included with DISTRONIC PLUS). If the driver in front brakes sharply or you suddenly find yourself on a collision course, the E-Class Coupé and Cabriolet can spot the danger via the DISTRONIC PLUS system's radar sensors. The Pre-Safe® Brake then briefly applies the brakes, and Brake Assist Plus can also intervene to provide emergency braking assistance if necessary.

**Neck-Pro head restraints** (standard). Fitted to both front seats, the Neck-Pro head restraints

automatically move forwards and upwards in the event of a rear-end collision. This enables them to support the head sooner and reduce strain on the spine.

**Active Bonnet** (standard). The E-Class Coupé and Cabriolet come with an innovative Active Bonnet system. In the event of a collision, the rear of the bonnet is raised by 50 mm, helping to reduce the risk of injury to pedestrians and cyclists.

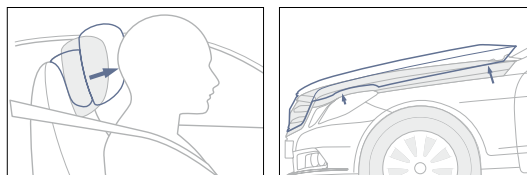

The Neck-Pro head restraints reduce the risk of whiplash in a rear-end collision

Active Bonnet is part of the Mercedes-Benz protection system for more vulnerable road users

**Airbags** (standard/optional). Every E-Class Coupé and Cabriolet is fitted with multi-stage front airbags, front sidebags, pelvisbag and windowbags that provide head protection for all occupants. There's also a standard kneebag that reduces the risk of injury to the driver's legs and knees, plus optional sidebags for the rear.



## Cabriolet safety features

For maximum peace of mind, the E-Class Cabriolet comes with occupant protection systems that are tailored to the needs of open-top motoring – such as a roll-over protection system that meets the highest standards of safety and design.

**High-strength bodyshell** (standard). The E-Class Cabriolet's bodyshell is designed from the outset to provide optimum safety for its occupants. Made largely of particularly high tensile steels, it features additional strengthening for



The airbags are tailored both to the human body shape and the Cabriolet body and offer effective all-round protection

the open-top version, in particular in the floor and sides. The resulting torsional rigidity, combined with the intelligent use of lightweight materials, also helps to ensure exceptionally agile handling.

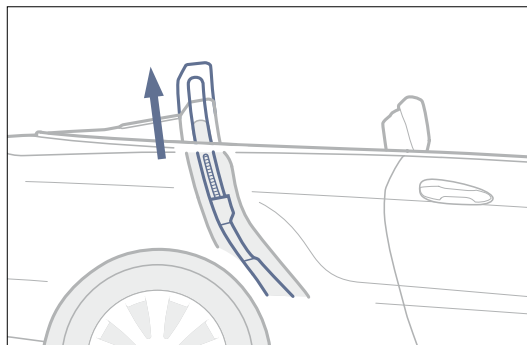

The roll-over bars activate in just 0.3 seconds. They are integrated into the rear seat head restraints, which then move automatically to their highest position

**Roll-over protection** (standard). The windscreen surround and A-pillars have also been strengthened. The latter feature reinforcing tubes that, together with the roll-over bars, ensure effective protection should the car overturn in an accident. The roll-over bars themselves are fully integrated into the rear seat head restraints and anchored to the bodywork behind the rear seat. They can be activated within a split-second of the airbag system's crash sensors detecting a likely accident.







Along with roll-over bars and strengthened A-pillars, the use of different-grade steels in the E-Class Cabriolet's bodywork helps to further increase occupant protection



## Audio and navigation

The E-Class Coupé and Cabriolet come with a choice of high-quality audio and navigation systems. They can be operated easily and ergonomically via the multi-function steering wheel, central controller or optional Linguatronic voice control.

### Central display unit and controller (standard).

On the E-Class Coupé and Cabriolet, the menus for the audio system and optional navigation can be accessed via the controller between the seats and viewed in colour on the central display unit. In addition, many functions can be operated via the multi-function steering wheel.



The ergonomic controller is situated just in front of the centre armrest

**COMAND multimedia system with Media Interface (optional).** COMAND combines navigation, audio and telephone functionality, displaying all information on its 7-inch colour display. The integrated DVD drive plays CDs and MP3 discs as well as video and audio DVDs. Linguatronic voice control enables hands-free operation.



Free updates for your map data for three years (per car, from first registration only)

**Harman Kardon® Logic 7® surround sound system (optional).** With 12 speakers, including one subwoofer, a 450-watt output and Dolby Digital 5.1, the surround sound system brings high-end audio to your E-Class Coupé or Cabriolet. It also comes with speed-sensitive volume adjustment, ensuring an optimum listening experience at all times.



The Harman Kardon® Logic 7® surround sound system turns the cabin into a mobile concert hall



## Electronic assistants

The many electronic assistants fitted to the E-Class Coupé and Cabriolet make for more relaxing driving and easier parking manoeuvres.

**Parktronic with Advanced Parking Guidance** (standard). These intelligent parking aids help you to find a suitably sized gap and manoeuvre safely into it. When driving at low speeds, the ultrasound sensors automatically measure up potential parking spaces. If they find one that fits the bill, the system guides you precisely in, telling you when to turn and when to straighten up.



Advanced Parking Guidance alerts you to suitable parking spaces and guides you expertly in

**Reversing camera** (optional). This rear-mounted camera is useful when parking or reversing. It captures what's immediately behind the car using a wide-angle lens and shows the picture on the central display unit.



The reversing camera shows you the hard-to-see area immediately behind the car



## Open-top comfort

Thanks to innovative cabriolet technology, you can continue to enjoy open-top motoring long after the summer ends. What's more, by reducing turbulence and noise levels, the exceptional aerodynamics and ingenious Aircap system make the E-Class Cabriolet a pleasure for rear seat occupants too.

**Aircap** (standard). A world first, the E-Class Cabriolet's Aircap system is an evolution of the conventional wind deflector. It comprises a deflector on the top edge of the windscreen surround and a small draught-stop between the rear seat head restraints. Together, they force

the air flow upwards, keeping it away from the occupants' heads. This not only increases comfort for those in the rear by minimising turbulence and draughts, it also makes for easier communication between front and rear seat passengers as well as enhancing

the effectiveness of the automatic climate control system. Aircap is switched on and off via a button in the centre console and can be activated or deactivated even at high speeds. Its components also retract automatically during parking.

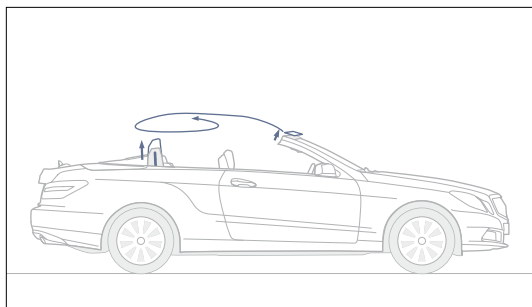

The Aircap system diverts air flowing over the cabin, forcing it upwards and reducing turbulence for those in the rear



Aircap includes an electrically operated wind deflector fitted to the front windscreen surround



Thanks to Aircap's neck-level vents, front seat occupants can enjoy chill-free open-top motoring even in cooler weather



**Airscarf** (optional). Our Airscarf neck-level heating system gives you a longer open-top driving season. At the touch of a button, it sends warm air to the head and neck area via discreetly integrated vents in the front seat head restraints, allowing you to keep the top down even when the temperature drops.

**Aerodynamics.** The E-Class Cabriolet's excellent aerodynamics help to maximise fuel efficiency and minimise noise levels. In E 200 CGI BlueEFFICIENCY guise, it boasts a drag coefficient of just 0.28 Cd (with the roof closed).



With Aircap and Airscarf, the E-Class Cabriolet offers calm and comfortable open-top motoring for four



## Soft-top and boot space

The E-Class Cabriolet's fully electric soft-top offers excellent noise and heat insulation, opens and closes at speeds of up to 25 mph, and leaves you with plenty of luggage space when folded away.

**Fully electric soft-top.** Available in a choice of four colours, the E-Class Cabriolet's soft-top is both technically advanced and thoroughly weatherproof. It is operated by lifting and holding the soft-top release lever situated within the



The soft-top release lever is concealed within the handrest for the central controller

central handrest and can be opened or closed when travelling at speeds of up to approximately 25 mph. It can also be opened remotely using the infrared release on the car key. The fabric construction and electro-hydraulic folding



Thanks to the Aircap system, even those in the rear can enjoy unruffled open-top motoring

mechanism enables the soft-top to fold neatly away, leaving ample boot space even with the roof down (the E-Class Cabriolet has one of the largest boots in its class). As a result, the E-Class Cabriolet offers open-top enjoyment for four.



The E-Class Cabriolet boot offers ample luggage space even with the roof down



The E-Class Cabriolet also scores when it comes to refinement, particularly at speed, thanks to a range of measures that help to minimise the amount of wind noise. These include highly effective seals for the soft-top, the aerodynamic design of exterior features such as the tail lights and radiator blind, and aerodynamic detailing on the bodyshell, external components and trim.



## Climate control systems

A comfortable cabin climate makes for a relaxed, alert driver and contented passengers. With either two or three separate temperature zones, the E-Class Coupé and Cabriolet help to keep everyone happy.

**Automatic climate control** (standard). The two-zone automatic climate control system maintains your chosen temperature and that of your front seat passenger – independently. Besides monitoring the temperature inside and outside the cabin, the system's sensors also measure

the intensity and angle of sunlight, enabling it to compensate accordingly. In addition, a windscreen defroster vent, an air recirculation function and a particulate filter are all fitted as standard.

**Luxury automatic climate control** (optional; standard on E 500). With three-zone luxury automatic climate control, rear seat occupants can set their own preferred temperature too. The system compensates automatically for external factors such as sunlight, air quality and humidity, and lets you choose between three different air flow styles: diffuse, medium and focused.



Luxury automatic climate control allows those in the front and rear to select different temperature settings







## Seats

The seats for the E-Class Coupé and Cabriolet combine comfort, safety and ergonomic support. For extra convenience, they come with automatic seat belt hand-over in the front.



The multi-contour seats adapt to their occupants for optimum ergonomic support

The front seats are ergonomically shaped, highly supportive even in fast cornering, and electrically adjustable for height and backrest angle. In addition, they are fitted with safety-enhancing Neck-Pro head restraints.

With the comfort-ventilated seats option, the driver and front passenger benefit from active heating and cooling. This is available both for the standard SE seats and the Sport's multi-contour front seats, which feature air chambers in the lumbar area, side bolsters and seat cushion. By inflating these chambers electrically, the multi-contour seats can adapt to the shape of each occupant.



**Automatic seat belt hand-over** (standard).

As soon as you turn the key, the seat belt hand-over system automatically brings your seat belt to within easy reach. It can also be activated manually via a button on the upper centre console.



The automatic seat belt hand-over system brings the front seat belts within easy reach

**Easy-Entry system** (standard). The front seats of the E-Class Coupé and Cabriolet slide forward to provide easier rear seat access. If the optional Memory Package is fitted (standard on the E 500), the seat moves to the Easy-Entry position and back electrically.



The Easy-Entry system enables the front seats to slide forward for better access to the rear

**Sculpted rear seats** (standard). Rear passengers benefit from sculpted rear seats with integral head restraints, plus a centre storage compartment and twin cup holders. On the Coupé, the backrest can be folded forward to increase the load capacity.



Comfortable sculpted seats ensure those in the rear enjoy the journey too



## E-Class Coupé SE

The new E-Class Coupé exudes exclusivity inside and out, with daytime running lights, LED tail lights and equipment levels that are generous to a fault. On the SE, heated front seats, partial electric seat adjustment and Speedtronic cruise control are just a few of the many attractive items fitted as standard.



---

### EXTERIOR

---

17" alloy wheels - 5-twin-spoke design

---

Agility Control suspension

---

Front and rear Parktronic with Advanced Parking Guidance

---

Rain-sensing wipers

---

### INTERIOR

---

Leather upholstery

---

Automatic climate control with digital display

---

Audio 20 radio with single CD drive, 5.8" colour display and central controller dial, with aux-in socket located in glove compartment

---

Bluetooth® interface for hands-free telephony

---

Nappa leather-trimmed steering wheel and gear shift lever

---

Heated front seats

---

ISOFIX child seat fixings in rear

---



## E-Class Cabriolet SE

Eye-catching lines and exclusive appointments make the E-Class Cabriolet SE a truly special travelling companion. The traditional soft-top, distinctive twin headlamps and LED tail lights ensure it always stands out from the crowd, while the high-quality interior offers luxurious comfort for four.



---

### EXTERIOR

Fully electric acoustic soft-top in Black, Dark Blue, Dark Beige or Red (Cabriolet only)

Aircap system – front wind deflector and draught stop between rear head restraints (Cabriolet only)

---

### INTERIOR

Operating console for roof functions under centre armrest (Cabriolet only)

Through-loading feature under rear seat centre armrest (Cabriolet only)

---





The SE interior features a black instrument cluster

## SE upholstery and trim

The SE features a tone-on-tone interior with light trim for the A- and C-pillars and roof lining, plus a subtly contrasting colour for the dashboard, steering wheel and gear shift lever.

---

### BLACK

201 Leather

801 Nappa leather

---

### REEF GREY/ALPACA GREY

208 Leather

808 Nappa leather

---

### MOCHA BROWN/ALMOND BEIGE

205 Leather

805 Nappa leather

---

### TRIM

739 Aluminium, brushed<sup>1</sup>

731 Burr Walnut (optional)

H13 Brown Pine (optional)

H21 Black Piano Lacquer<sup>1</sup>

---

<sup>1</sup>Not available in conjunction with Almond Beige upholstery



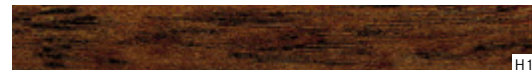
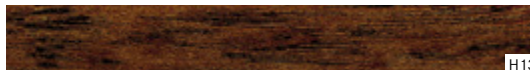
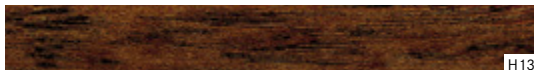
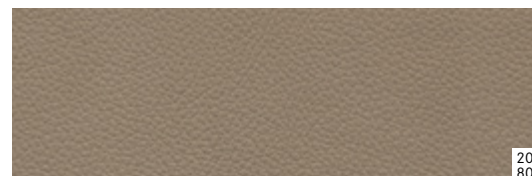
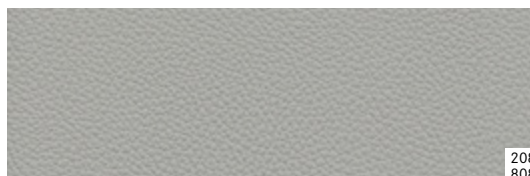
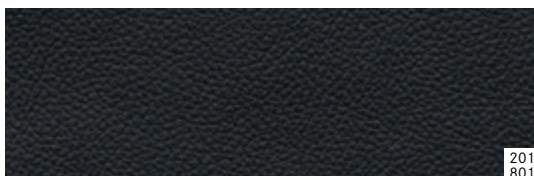

## E-Class Coupé and Cabriolet Sport



The Sport model has a distinctly athletic personality, thanks to all-round AMG body-styling featuring AMG front and rear aprons and side skirts. To match, there are also 18" AMG 6-twin-spoke alloy wheels in polished chrome and large drilled front brake discs plus calipers with visible 'Mercedes-Benz' lettering.

The E-Class Coupé Sport shown above features the optional panoramic sunroof







---

**EXTERIOR**

---

18" AMG 6-twin-spoke alloy wheels

---

Agility Control sports suspension

---

AMG bodystyling comprising front and rear aprons plus side skirts

---

Large drilled front brake discs and brake calipers with  
'Mercedes-Benz' lettering

---

Parameter steering with more direct steering ratio

---

Fully electric acoustic soft-top in Black, Dark Blue, Dark Beige or  
Red (Cabriolet only)

---

Aircap system – front wind deflector and draught stop between  
rear head restraints (Cabriolet only)

---





E500 interior images shown



## Sport interior

The Sport interior picks up where the dynamic-looking exterior leaves off, with multi-contour front seats in Artico artificial leather, a nappa leather-trimmed AMG sports steering wheel, floor mats with 'AMG' lettering and stylish and functional sports pedals in brushed aluminium. As an option, there's full leather upholstery in a choice of Alpaca Grey, Almond Beige, Natural Beige, Flamenco Red or Black, while sumptuous nappa leather is also available – in either Alpaca Grey, Almond Beige or Black.

---

### INTERIOR

---

AMG sports steering wheel in nappa leather

---

Black Artico artificial leather upholstery with contrasting stitching; optional leather or nappa leather upholstery and wood trim

---

Floor mats with 'AMG' lettering

---

Multi-contour front seats

---

Steering wheel shift paddles (automatic transmission only)

---

Sports pedals in brushed stainless steel with rubber studs

---

Operating console for roof functions under the centre armrest (Cabriolet only)

---

Through-loading feature under rear seat centre armrest (Cabriolet only)

---





The Sport interior features a silver-finish instrument cluster

## Sport upholstery and trim

The Sport model seats, door trims and rear side panels come with Black Artico<sup>1</sup> as standard or five choices of optional leather upholsteries. The roof lining and pillar trims are in black.

---

### BLACK/BLACK

101 Artico<sup>1</sup>

251 Leather

851 Nappa leather

---

### BLACK/ALPACA GREY

258 Leather

858 Nappa leather

---

### BLACK/ALMOND BEIGE

255 Leather

855 Nappa leather

---

### BLACK/NATURAL BEIGE

254 Leather

---

### BLACK/FLAMENCO RED

257 Leather

---

### TRIM

739 Aluminium, brushed<sup>2</sup>

736 Black Ash (optional)

H21 Black Piano Lacquer (Cabriolet only)

---

<sup>1</sup>Artificial leather

<sup>2</sup>Not available in conjunction with Almond Beige upholstery



Interiors shown represent colours only, not equipment

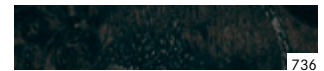
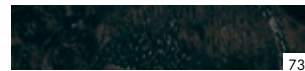
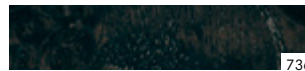
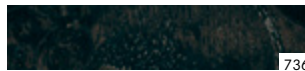
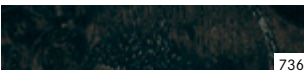
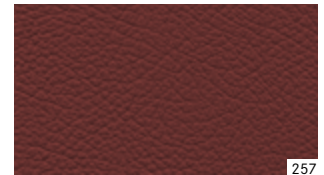
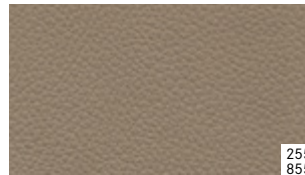
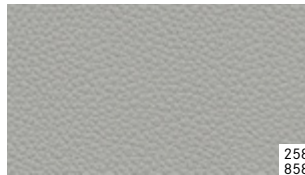
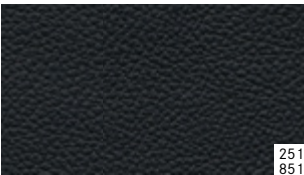
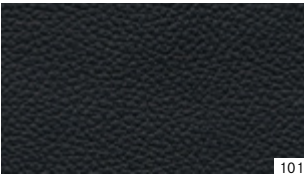

## *designo*

Created to satisfy even the most discerning of drivers, *designo* upholstery and trim lends your E-Class Coupé or Cabriolet an even more exclusive look.

Carefully chosen materials and exceptional craftsmanship make every *designo* interior a masterpiece. For the E-Class Coupé and Cabriolet, the options include two-tone leather upholstery with a special *designo* seat design, plus front and rear door panels in exclusive porcelain *designo* leather. Also available are additional leather appointments that add a further touch of elegance. For more information visit [www.mercedes-benz.co.uk/designo](http://www.mercedes-benz.co.uk/designo)



Shift lever surround in porcelain leather



Porcelain leather seats with metal *designo* badge





## Standard equipment | Selection



Projection-beam headlights, fog lamps and daytime running lights (standard on SE only)



Rain sensor and light sensor for the Active Light System



Soft-top release lever for Cabriolet



Airbag wind deflector for Cabriolet



Tyre pressure loss warning



12-button multi-function steering wheel in nappa leather



Audio 20 CD with single CD



Seat belt hand-over button on centre console





## Optional extras | Selection



Light Package: Intelligent Light System with LED daytime running lights (standard on Sport)

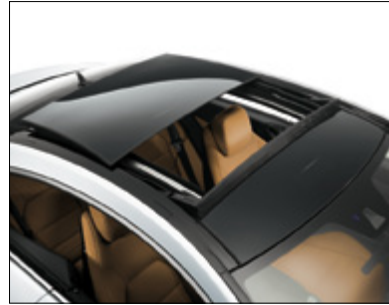

Panoramic glass sunroof for Coupé



Luxury automatic climate control



Airscarf neck-level heating system for Cabriolet



DISTRONIC PLUS radar-assisted cruise control



Linguatronic voice control button on steering wheel (part of COMAND)



COMAND multimedia system with Media Interface



Memory Package



## Alloy wheels



17" 5-twin-spoke alloy wheels (code R11, standard on SE)



18" AMG 6-twin-spoke alloy wheels (code 786, standard on Sport)



17" 9-twin-spoke alloy wheels (code 31R, optional on SE)



18" 5-spoke alloy wheels (code R32, optional on SE – includes sports suspension, code 486)



18" AMG 5-twin-spoke alloy wheels, burnished (code 795, optional on Sport, Cabriolet only)





19" AMG 7-twin-spoke design alloy wheels (code 770, optional)



17" incenio 'Khotrima' 5-twin-spoke design alloy wheels  
(Retailer-fit accessory)



17" 10-twin-spoke alloy wheels (Retailer-fit accessory)



18" incenio 'Shikrio' 5-twin-spoke design alloy wheels  
(Retailer-fit accessory)



## Retailer-fit accessories

Your Mercedes-Benz Retailer offers a range of accessories designed specially for the E-Class Coupé and Cabriolet.

The accessories range includes practical load-carrying solutions such as Alustyle roof bars and 330- or 450-litre roof boxes, or a ski and snowboard rack that holds up to six pairs of skis or four boards.<sup>1</sup> There's also a variety of products for the luggage compartment, such as a protective boot liner made of food-safe

material. For personalised in-car entertainment, the iPod® interface kit enables an iPod® or iPhone® to be integrated with the audio system. It can then be operated via the multi-function steering wheel, with the current playlist displayed in the instrument panel.

For more information about these and other accessories, talk to your Mercedes-Benz Retailer or consult the relevant accessories brochure.



Alustyle roof bars with ski and snowboard rack



The iPod® interface kit



Protective boot liner

<sup>1</sup>Roof bars, racks and boxes available for Coupé only





Alustyle roof bars with roof box



## Following the star

**Roadside Assistance.** Rest assured that should you ever need help, Mercedes-Benz Roadside Assistance is there for you. In the unlikely event of a technical breakdown<sup>1</sup> you can rely on the Mercedes-Benz Roadside Assistance Team – anywhere in Europe. Simply phone our Customer Assistance Centre on 00800 1 777 7777,<sup>2</sup> where our specialists will organise assistance for you. Also standard is the Mercedes-Benz mobility package.<sup>3</sup> Whether you lose your key, run out of fuel or if your vehicle is damaged due to an accident or vandalism, Mobilo ensures that you still reach your destination. Often the problem can be rectified on the spot, but if this is not possible, we will naturally ensure that your vehicle is taken to the nearest Mercedes-Benz Official Workshop to get you back on the road as quickly as possible.

<sup>1</sup>Technical breakdown cover is initially valid for your vehicle for four years from the date of first registration. This can be extended from the fifth year, up to a maximum of 30 years, on completion of each scheduled maintenance service, providing that this service is carried out by a Mercedes-Benz Official Workshop

**Mercedes-Benz Finance.** At Mercedes-Benz Finance, our single-minded aim is to provide optimum financial solutions for all those who share the Mercedes-Benz philosophy of absolute commitment to quality. Whether you are a private customer or a business user, our finance and leasing packages can be tailored to meet your individual needs. And since our name is synonymous with reliability, who better to trust with your insurance? For further information on Mercedes-Benz Finance, please contact your local Mercedes-Benz Retailer.

<sup>2</sup>In non-affiliated European countries: +49 20 7975 7077

<sup>3</sup>This cover can be retained from the fifth year. Your Mercedes-Benz Official Workshop will provide details of how to renew this cover once your initial four year term has expired

**Mercedes-Benz Insurance** offers a fully comprehensive 5 star<sup>4</sup> motor insurance policy specifically designed to give you the cover you would expect from Mercedes-Benz. For a quotation, please call 0845 600 2180.<sup>5</sup>



<sup>4</sup>As rated 5 by Defaqto, a leading independent financial research company. Mercedes-Benz Motor Insurance is underwritten by Aviva Insurance UK Limited  
<sup>5</sup>Calls are charged at local rate and may be recorded. Terms and conditions apply. Mercedes-Benz Motor Insurance is underwritten by Aviva Insurance UK Limited



**Test drive.** A Mercedes-Benz is most at home on the road. This is the only way to experience the effortlessly superior driving feel that lends every Mercedes model its inimitable class.

Feel the power of efficient engines with low fuel consumption, and precise steering designed to put you in the mood for driving. And experience what true comfort really feels like. The unique feeling of driving a Mercedes cannot be put into words, however. Which is precisely why we'd like to invite you to take a test drive.

Your Mercedes-Benz Retailer will be happy to make all the necessary arrangements for you. Simply visit [www.mercedes-benz.co.uk](http://www.mercedes-benz.co.uk) to locate the nearest Mercedes-Benz Retailer.

We look forward to seeing you.

**Interactive Owner's Manual.** The website also offers an interactive tour, enabling you to take a closer look at your desired model. This simulation is the ideal way to acquaint yourself with your dream car. You can view key functions in detail, gain an insight into the car's inner workings or look at the benefits of each model.

For further details, visit

[www.mercedes-benz.co.uk/eclasscoupemannual](http://www.mercedes-benz.co.uk/eclasscoupemannual)

[www.mercedes-benz.co.uk/eclasscabrioletmanual](http://www.mercedes-benz.co.uk/eclasscabrioletmanual)



## Mercedes-Benz low rate and deposit contribution finance offers

### Representative example

#### E 350 CDI BlueEFFICIENCY Sport Coupé with metallic paint

|                               |            |
|-------------------------------|------------|
| 36 monthly payments of **     | £509.00    |
| On-the-road price             | £39,410.00 |
| Customer deposit              | £6,779.70  |
| Retailer deposit contribution | £500.00    |
| Duration of agreement         | 36 months  |
| Optional purchase payment†    | £19,150.00 |
| Acceptance fee                | £180.00    |
| Purchase activation fee†      | £95.00     |
| Amount of credit              | £32,130.30 |
| Total amount payable††        | £45,028.70 |
| Representative APR            | 7.4% APR   |
| Fixed interest rate           | 6.84%      |

### Example offers – 7.4% APR Representative

|                                      | Metallic paint | Automatic transmission | Leather | Parktronic | On-the-road price | Retailer deposit contribution | Customer deposit | 36 monthly payments of** |
|--------------------------------------|----------------|------------------------|---------|------------|-------------------|-------------------------------|------------------|--------------------------|
| E 220 CDI BlueEFFICIENCY SE Coupé    | ●              |                        | ●       | ●          | £32,480.00        | £500.00                       | £5,216.28        | £419.00                  |
| E 220 CDI BlueEFFICIENCY Sport Coupé | ●              | ●                      |         | ●          | £36,080.00        | £500.00                       | £6,057.08        | £445.00                  |
| E 350 CDI BlueEFFICIENCY Sport Coupé | ●              | ●                      |         | ●          | £39,410.00        | £500.00                       | £6,779.70        | £509.00                  |

Whilst these offers are only available with Mercedes-Benz Finance, our Mercedes-Benz Retailers do arrange finance on behalf of other finance companies as well

This finance campaign is available on all E-Class Cabriolet models ordered/credit approved between 1 April and 30 June and registered by 30 September 2011 † Payable if you exercise the option to purchase the car †† Includes optional purchase payment, purchase activation fee and retailer deposit contribution \*\* Based on a Mercedes-Benz Agility agreement and 10,000 miles per annum. Excess mileage charges may apply. Quotations available on request for alternative contract lengths and mileages. Guarantees and indemnities may be required. Credit provided subject to status from Mercedes-Benz Financial Services UK Ltd, MK7 8ND † Please speak to your Mercedes-Benz Retailer for payment terms and suitable cover periods

## Mercedes-Benz Service Care

### Add Mercedes-Benz Service Care for £31.00 per month†

- Maintained by Mercedes-Benz Official Workshops
- Mercedes-Benz trained technicians
- Meets requirements of Mercedes-Benz Agility finance agreement

## Mercedes-Benz Motor Insurance

- 24-hour, seven days a week UK accident recovery
- Only genuine Mercedes-Benz parts used
- To qualify for up to 10% discount go to [www.mercedes-benz.co.uk/motorinsurance](http://www.mercedes-benz.co.uk/motorinsurance)
- Alternatively, call Mercedes-Benz Motor Insurance now on **0845 600 2180** for an annual quote

We may decline to quote in some circumstances. Cover not available in Northern Ireland

- Standard and optional equipment included in the price



## Mercedes-Benz low rate and deposit contribution finance offers

### Representative example

#### E 350 CDI BlueEFFICIENCY Sport Cabriolet with metallic paint

|                               |            |
|-------------------------------|------------|
| 36 monthly payments of **     | £5 19.00   |
| On-the-road price             | £42,905.00 |
| Customer deposit              | £7,923.70  |
| Retailer deposit contribution | £0.00      |
| Duration of agreement         | 36 months  |
| Optional purchase payment†    | £22,250.00 |
| Acceptance fee                | £ 180.00   |
| Purchase activation fee†      | £95.00     |
| Amount of credit              | £34,981.30 |
| Total amount payable††        | £49,132.70 |
| Representative APR            | 7.4% APR   |
| Fixed interest rate           | 6.84%      |

### Example offers – 7.4% APR Representative

|  | Metallic paint | Automatic transmission | Leather | Parktronic | On-the-road price | Retailer deposit contribution | Customer deposit | 36 monthly payments of** |
|--|----------------|------------------------|---------|------------|-------------------|-------------------------------|------------------|--------------------------|
| E 220 CDI BlueEFFICIENCY SE Cabriolet    | ●              |                        | ●       | ●          | £35,865.00        | £0.00                         | £6,372.52        | £429.00                  |
| E 220 CDI BlueEFFICIENCY Sport Cabriolet | ●              | ●                      |         | ●          | £39,450.00        | £0.00                         | £7,198.32        | £455.00                  |
| E 350 CDI BlueEFFICIENCY Sport Cabriolet | ●              | ●                      |         | ●          | £42,905.00        | £0.00                         | £7,923.70        | £519.00                  |

Whilst these offers are only available with Mercedes-Benz Finance, our Mercedes-Benz Retailers do arrange finance on behalf of other finance companies as well

This finance campaign is available on all E-Class Cabriolet models ordered/credit approved between 1 April and 30 June and registered by 30 September 2011 † Payable if you exercise the option to purchase the car †† Includes optional purchase payment and purchase activation fee \*\* Based on a Mercedes-Benz Agility agreement and 10,000 miles per annum. Excess mileage charges may apply. Quotations available on request for alternative contract lengths and mileages. Guarantees and indemnities may be required. Credit provided subject to status from Mercedes-Benz Financial Services UK Ltd, MK7 8ND † Please speak to your Mercedes-Benz Retailer for payment terms and suitable cover periods

## Mercedes-Benz Service Care

### Add Mercedes-Benz Service Care for £31.00 per month†

- Maintained by Mercedes-Benz Official Workshops
- Mercedes-Benz trained technicians
- Meets requirements of Mercedes-Benz Agility finance agreement.

## Mercedes-Benz Motor Insurance

- 24-hour, seven days a week UK accident recovery
- Only genuine Mercedes-Benz parts used
- To qualify for up to 10% discount go to [www.mercedes-benz.co.uk/motorinsurance](http://www.mercedes-benz.co.uk/motorinsurance)
- Alternatively, call Mercedes-Benz Motor Insurance now on **0845 600 2180** for an annual quote

We may decline to quote in some circumstances. Cover not available in Northern Ireland

● Standard and optional equipment included in the price

# Technical data:

## Coupé

|   |  |
|---|--|
| No. of cylinders/arrangement  |  |
| Total displacement – cc   |  |
| Rated output <sup>2</sup> – hp (kW) at rpm: man.<br>auto.                       |  |
| Rated torque <sup>2</sup> – Nm at rpm: man.<br>auto.                            |  |
| Compression ratio   |  |
| Acceleration from 0–62 – sec. (auto.)   |  |
| Top speed approx. – mph (auto.)   |  |
| Tyre size – front<br>rear   |  |
| Fuel consumption <sup>4</sup> – mpg (auto.)<br>urban<br>extra-urban<br>combined |  |
| CO <sub>2</sub> emissions, <sup>4</sup> combined – g/km (auto.)                 |  |
| Tank capacity/incl. reserve, approx. – l  |  |
| Load capacity – l   |  |
| Turning circle diameter – m   |  |
| Kerb weight <sup>5</sup> – kg (auto.)   |  |
| Perm. GVW – kg (auto.)  |  |

### DIESEL ENGINES

| E 220 CDI BE <sup>1</sup> | E 250 CDI BE <sup>1</sup> | E 350 CDI BE <sup>1</sup> |
|---------------------------|---------------------------|---------------------------|
| 4/in-line                 | 4/in-line                 | 6/V                       |
| 2,143                     | 2,143                     | 2,987                     |
| 170 (125)/3,000           | 204 (150)/4,200           | –                         |
| 170 (125)/3,000           | 204 (150)/4,200           | 231 (170)/3,800           |
| 400/1,400–2,800           | 500/1,600–1,800           | –                         |
| 400/1,400–2,800           | 500/1,600–1,800           | 540/1,600–2,400           |
| 16.2:1                    | 16.2:1                    | 15.5:1                    |
| 8.5 (8.5)                 | 7.4 (7.4)                 | – (6.7)                   |
| 146 (145)                 | 155 <sup>3</sup> (153)    | – (155 <sup>3</sup> )     |
| 235/45 R 17               | 235/45 R 17               | 235/45 R 17               |
| 235/45 R 17               | 235/45 R 17               | 235/45 R 17               |
| 42.2 (34.4)               | 40.4 (34.4)               | – (31.7)                  |
| 64.2 (62.8)               | 62.8 (62.8)               | – (50.4)                  |
| 53.3 (47.9)               | 52.3 (47.9)               | – (41.5)                  |
| 139 (155)                 | 143 (155)                 | 179                       |
| 66/8                      | 66/8                      | 66/8                      |
| 450                       | 450                       | 450                       |
| 10.95                     | 10.95                     | 10.95                     |
| 1,660 (1,670)             | 1,695 (1,690)             | – (1,730)                 |
| 2,130 (2,140)             | 2,165 (2,160)             | – (2,180)                 |

### PETROL ENGINES

| E 200 CGI BE <sup>1</sup> | E 250 CGI BE <sup>1</sup> | E 350 CGI BE <sup>1</sup> | E 500                 |
|---------------------------|---------------------------|---------------------------|-----------------------|
| 4/in-line                 | 4/in-line                 | 6/V                       | 8/V                   |
| 1,796                     | 1,796                     | 3,498                     | 5,461                 |
| 184 (135)/5,250           | –                         | –                         | –                     |
| 184 (135)/5,250           | 204 (150)/5,500           | 292 (215)/6,400           | 387 (285)/6,000       |
| 270/1,800–4,600           | –                         | –                         | –                     |
| 270/1,800–4,600           | 310/2,000–4,300           | 365/3,000–5,100           | 530/2,800–4,800       |
| 9.3:1                     | 9.3:1                     | 12.2:1                    | 10.7:1                |
| 8.5 (8.3)                 | – (7.4)                   | – (6.3)                   | – (5.2)               |
| 149 (147)                 | – (155 <sup>3</sup> )     | – (155 <sup>3</sup> )     | – (155 <sup>3</sup> ) |
| 235/45 R 17               | 235/45 R 17               | 235/45 R 17               | 235/40 R 18           |
| 235/45 R 17               | 235/45 R 17               | 235/45 R 17               | 255/35 R 18           |
| 28.5 (26.6)               | – (25.9)                  | – (23.0)                  | – (17.5)              |
| 49.6 (47.9)               | – (47.1)                  | – (44.1)                  | – (36.2)              |
| 38.7 (36.7)               | – (36.2)                  | – (32.8)                  | – (25.9)              |
| 168 (179)                 | – (180)                   | – (200)                   | – (254)               |
| 66/8                      | 66/8                      | 66/8                      | 66/8                  |
| 450                       | 450                       | 450                       | 450                   |
| 10.95                     | 10.95                     | 10.95                     | 10.95                 |
| 1,560 (1,560)             | – (1,575)                 | – (1,670)                 | – (1,715)             |
| 2,030 (2,030)             | – (2,045)                 | – (2,140)                 | – (2,180)             |

<sup>1</sup>BlueEFFICIENCY <sup>2</sup>Figures according to Directive 80/1269/EEC in the currently applicable version <sup>3</sup>Electronically limited <sup>4</sup>The figures shown were obtained in accordance with the prescribed measuring process (Directive 80/1268/EEC in the currently applicable version). The figures are not based on an individual vehicle and do not constitute part of the product offer; they are provided solely for purposes of comparison between different vehicle models and are subject to change. Please check with your local Retailer for the latest figures <sup>5</sup>Figures according to Directive 92/21/EC, version 95/48/EC (kerb weight with fuel tank 90% full, driver, 68 kg, and luggage, 7 kg) for standard specification vehicles. Optional extras and accessories will generally increase this figure and reduce the payload capacity accordingly



# Technical data:

## Cabriolet

|   |  |
|---|--|
| No. of cylinders/arrangement  |  |
| Total displacement – cc   |  |
| Rated output <sup>3</sup> – hp (kW) at rpm: man.<br>auto.                       |  |
| Rated torque <sup>3</sup> – Nm at rpm: man.<br>auto.                            |  |
| Compression ratio   |  |
| Acceleration from 0–62 – sec. (auto.)   |  |
| Top speed approx. – mph (auto.)   |  |
| Tyre size – front<br>rear   |  |
| Fuel consumption <sup>5</sup> – mpg (auto.)<br>urban<br>extra-urban<br>combined |  |
| CO <sub>2</sub> emissions <sup>5</sup> combined – g/km (auto.)                  |  |
| Tank capacity/incl. reserve, approx. – l  |  |
| Load capacity, roof up (roof down) – l  |  |
| Turning circle diameter – m   |  |
| Kerb weight <sup>6</sup> – kg (auto.)   |  |
| Perm. GVW – kg (auto.)  |  |

### DIESEL ENGINES

| E 220 CDI BE <sup>1</sup> | E 250 CDI BE <sup>1</sup> | E 350 CDI BE <sup>1</sup> |
|---------------------------|---------------------------|---------------------------|
| 4/in-line                 | 4/in-line                 | 6/V                       |
| 2,143                     | 2,143                     | 2,987                     |
| 170 (125)/3,000           | 204 (150)/4,200           | –                         |
| 170 (125)/3,000           | 204 (150)/4,200           | 231 (170)/3,800           |
| 400/1,400–2,800           | 500/1,600–1,800           | –                         |
| 400/1,400–2,800           | (500/1,600–1,800)         | 540/1,600–2,400           |
| 16.2:1                    | 16.2:1                    | 15.5:1                    |
| 8.8 (8.9)                 | 7.8 (7.8)                 | – (6.9)                   |
| 144 (143)                 | 152 (151)                 | – (155 <sup>4</sup> )     |
| 235/45 R 17               | 235/45 R 17               | 235/45 R 17               |
| 235/45 R 17               | 235/45 R 17               | 235/45 R 17               |
| 40.9 (34.0)               | 38.7 (34.0)               | – (31.0)                  |
| 61.4 (60.1)               | 60.1 (60.1)               | – (47.9)                  |
| 52.3 (46.3)               | 50.4 (46.3)               | – (40.4)                  |
| 143 (159)                 | 148 (159)                 | – (185)                   |
| 66/8                      | 66/8                      | 66/8                      |
| 390 (300)                 | 390 (300)                 | 390 (300)                 |
| 11.0                      | 11.0                      | 11.0                      |
| 1,785 (1,795)             | 1,815 (1,810)             | – (1,845)                 |
| 2,255 (2,265)             | 2,285 (2,280)             | – (2,295)                 |

### PETROL ENGINES

| E 200 CGI BE <sup>1,2</sup> | E 250 CGI BE <sup>1</sup> | E 350 CGI BE <sup>1</sup> | E 500                 |
|-----------------------------|---------------------------|---------------------------|-----------------------|
| 4/in-line                   | 4/in-line                 | 6/V                       | 8/V                   |
| 1,796                       | 1,796                     | 3,498                     | 5,461                 |
| 184 (135)/5,250             | –                         | –                         | –                     |
| 184 (135)/5,250             | 204 (150)/5,500           | 292 (215)/6,400           | 387 (285)/6,000       |
| 270/1,800–4,600             | –                         | –                         | –                     |
| 270/1,800–4,600             | 310/2,000–4,300           | 365/3,000–5,100           | 530/2,800–4,800       |
| 9.3:1                       | 9.3:1                     | 12.2:1                    | 10.7:1                |
| 8.8 (8.6)                   | – (7.8)                   | – (6.8)                   | – (5.3)               |
| 147 (143)                   | – (155 <sup>4</sup> )     | – (155 <sup>4</sup> )     | – (155 <sup>4</sup> ) |
| 235/45 R 17                 | 235/45 R 17               | 235/45 R 17               | 235/40 R 18           |
| 235/45 R 17                 | 235/45 R 17               | 235/45 R 17               | 255/35 R 18           |
| 28.0 (25.7)                 | – (25.7)                  | – (22.1)                  | – (17.8)              |
| 48.7 (46.3)                 | – (46.3)                  | – (43.5)                  | – (34.4)              |
| 38.2 (35.8)                 | – (35.8)                  | – (32.1)                  | – (25.7)              |
| 172 (185)                   | – (185)                   | – (206)                   | – (257)               |
| 66/8                        | 66/8                      | 66/8                      | 66/8                  |
| 390 (300)                   | 390 (300)                 | 390 (300)                 | 390 (300)             |
| 11.0                        | 11.0                      | 11.0                      | 11.0                  |
| 1,685 (1,685)               | – (1,695)                 | – (1,790)                 | – (1,840)             |
| 2,155 (2,155)               | – (2,165)                 | – (2,260)                 | – (2,295)             |

<sup>1</sup>BlueEFFICIENCY <sup>2</sup>E 200 CGI manual with ECO start/stop will be available from June 2010 <sup>3</sup>Figures according to Directive 80/1269/EEC in the currently applicable version <sup>4</sup>Electronically limited <sup>5</sup>The figures shown were obtained in accordance with the prescribed measuring process (Directive 80/1268/EEC in the currently applicable version). The figures are not based on an individual vehicle and do not constitute part of the product offer; they are provided solely for purposes of comparison between different vehicle models and are subject to change. Please check with your local Retailer for the latest figures <sup>6</sup>Figures according to Directive 92/211/EC, version 95/48/EC (kerb weight with fuel tank 90% full, driver, 68 kg, and luggage, 7 kg) for standard specification vehicles. Optional extras and accessories will generally increase this figure and reduce the payload capacity accordingly

## Dimensions for Coupé

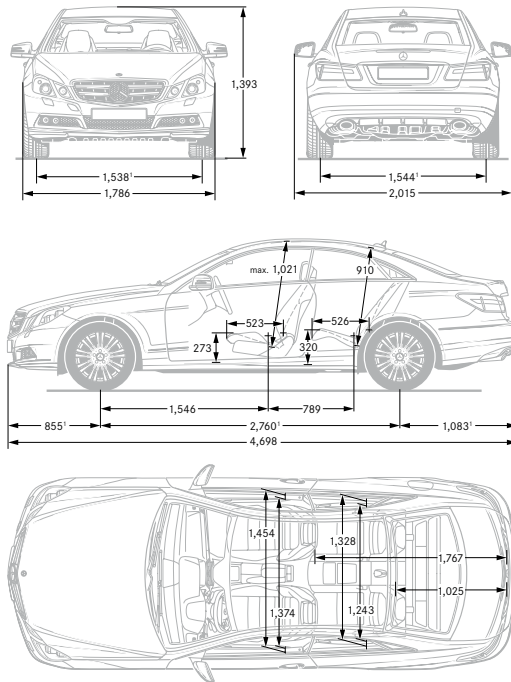

## Dimensions for Cabriolet

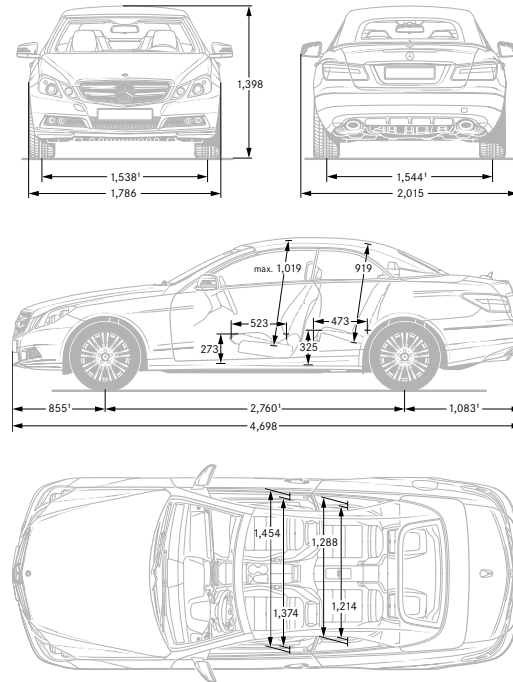

All measurements in millimetres. The dimensions shown are mean values and apply to standard-specification, unladen vehicles  
<sup>1</sup>With load of three persons, each 68 kg



# Paint finishes

The innovative Mercedes-Benz paint system is exceptionally durable and provides a deeper, longer-lasting sheen.

## NON-METALLIC PAINTS (standard)

- 040 Black
- 590 Fire Opal
- 650 Calcite White

## METALLIC PAINTS (optional)

- 197 Obsidian Black
- 230 Indigolite Blue
- 359 Tansanite Blue
- 755 Tenorite Grey
- 775 Iridium Silver
- 792 Palladium Silver
- 798 Sandine Beige
- 799 Diamond White

## SPECIAL METALLIC PAINT (optional)

- 786 Stannite Grey

## SOFT-TOP COLOURS (Cabriolet)

- 740 Black
- 744 Dark Blue
- 745 Dark Beige
- 746 Red

Further individual paint finishes are available from *designo*

## NON-METALLIC PAINTS

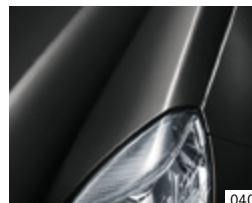

040



230



792



740

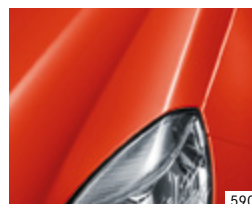

590



359



798



744

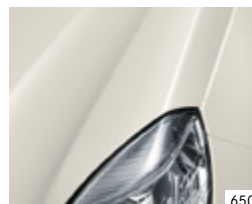

650

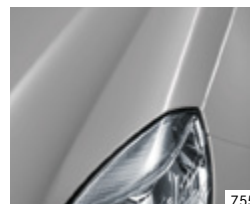

755



799



745

## METALLIC PAINTS

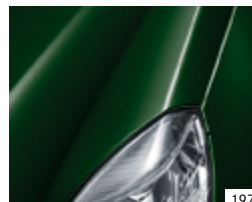

197



775

## SPECIAL METALLIC PAINT

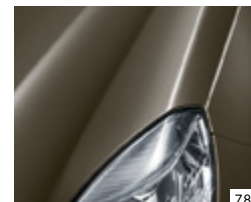

786



746



**Take-back of end-of-life vehicles. Coming full circle.** At the end of its long life, you can return your E-Class to us for environment-friendly disposal in accordance with the EC End-of-Life Vehicle Directive.<sup>1</sup> But that day lies a long way off.

<sup>1</sup>Applies in accordance with national regulations to vehicles up to 3.5 t permissible gross weight. The E-Class has met the statutory regulations governing the suitability of the vehicle's design for reuse and recycling for a number of years now. A network of vehicle take-back depots and dismantlers has been established which will process your vehicle in an environment-friendly manner. The ways in which both vehicles and parts can be recovered are subject to ongoing development and improvement. Consequently, the E-Class will be able to comply with any future increases in the recycling quota within the stipulated time limits. Further information is available at [www.mercedes-benz.co.uk](http://www.mercedes-benz.co.uk) or by calling 0808 156 6606.

**Please note:** this online version of the printed brochure may contain abridged copy or other content changes. The manufacturer reserves the right to make changes to the design, form, colour and specification during the delivery period, provided these changes, while taking into account the interests of the vendor, can be deemed reasonable with respect to the purchaser. Where the vendor or the manufacturer uses symbols or numbers to describe an order or the subject of an order, no rights may be derived solely from these. The illustrations may show accessories and items of optional equipment which are not part of standard specification. Colours may differ slightly from those shown. This brochure provides a general indication of the range of models, features, optional extras and/or colours available in various countries. Some of the models, features, optional extras and/or colours shown may not be available in your country or may only be available in a different specification. Additionally, some models, features, optional extras and/or colours may only be available in combination with others. For current and more specific information in relation to the range of models, features, optional extras and/or colours available in your country, and their pricing, you should contact your nearest authorised Mercedes-Benz Retailer. E&OE.

**Finance offers:** on-the-road costs include VAT, delivery, number plates, first registration fee, 12 months' road fund licence and fuel. Written quotations available on request from your local Mercedes-Benz Retailer. We reserve the right not to allow these subsidised interest rates to be used in conjunction with any other offer. Credit provided subject to status from Mercedes-Benz Financial Services UK Ltd. Guarantees and indemnities may be required. Offers are subject to availability. Mercedes-Benz Finance is a trading name of Mercedes-Benz Financial Services UK Limited. Registered in England No. 2472364. A Daimler Company. Registered Office: Burystead Court, Caldecotte Lake Drive, Caldecotte, Milton Keynes MK7 8ND. Tel. 0870 840 5000. Fax 0870 840 9000. [www.mercedes-benz.co.uk](http://www.mercedes-benz.co.uk)

