



GL-Class



Mercedes-Benz





First impressions

On or off the road, it's hard to find a Mercedes-Benz that is as versatile and as proficient in disciplines like driving dynamics, comfort, safety and individual styling. Advanced smart technology and a beautifully appointed interior provide the key to its unique strength. The new GL-Class is built to meet the highest demands in automotive technology, and of course, the highest demands of

the driver. The result is a heady mix of complete relaxation and control where a perfect day is measured by the miles travelled. Its size commands responsibility, offering a bold defence against the forces of nature. Discover the power of serenity in the new GL-Class.

[Overview](#) | [from page 4](#) [Insight](#) | [from page 13](#)

Featured models:
GL 350 BlueTEC AMG Sport Iridium Silver metallic front cover and from page 2 AMG bodystyling, AMG alloy wheels in 5-twin-spoke design, Black / Tobacco Brown leather upholstery and Brown Open-pore Ash wood trim
GL 350 BlueTEC AMG Sport with <i>designo</i> interior page 10 Optional <i>designo</i> Exclusive Porcelain leather upholstery (diamond design for GL 350 BlueTEC AMG Sport only), optional Anthracite Poplar wood trim
GL 63 AMG Cavansite Blue metallic from page 11 AMG bodystyling, AMG alloy wheels in 5-twin-spoke design

Specifications shown may include optional equipment and accessories

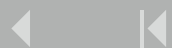

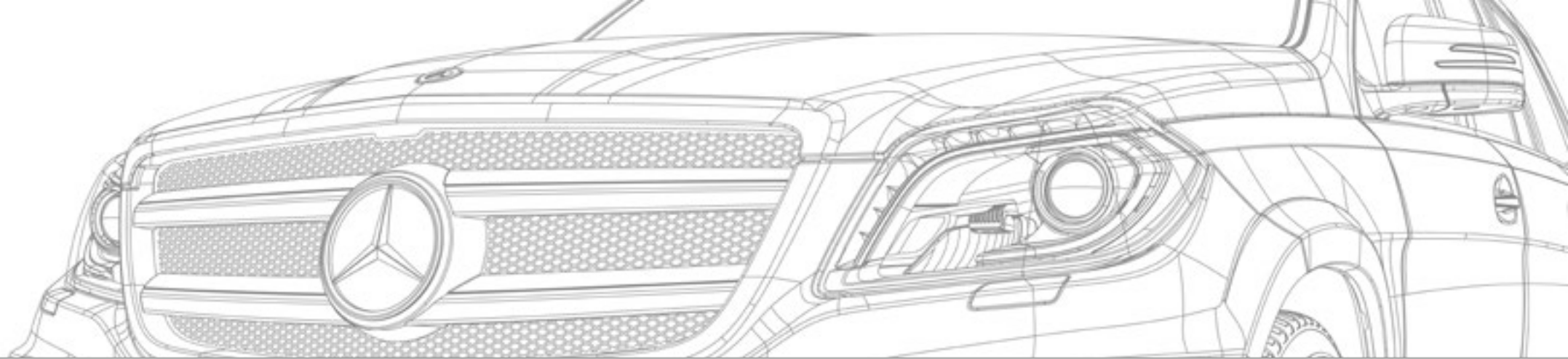

Facts

Obstacle-free serenity, full of responsibility:

Mercedes-Benz Intelligent Drive, BlueEFFICIENCY, AMG V8 petrol engine, transmission and suspension.

Engines and suspension | from page 16

Integrated safety in the GL-Class: safer driving, anticipating danger, protecting occupants and post-crash safety.

Safety | from page 26

Generous freedom – for complete relaxation:

climate control, three rows of seats, load compartment management, lighting, as well as multimedia and electronic assistants.

Comfort | from page 30

Exclusive performance for seven: GL 63 AMG exterior and interior.

AMG | from page 38

Individuality and inspiration: standard equipment and optional extras, upholstery and trim, alloy wheels and Retailer-fit accessories.

Equipment | from page 42

More Mercedes-Benz: test drive, Mercedes-Benz Finance and Insurance, Interactive Owner's Manual, Roadside Assistance and Accident Management, Service Care, and Mercedes-Benz World.

Services | from page 60

The GL in figures: dimensions, paint finishes, load compartment management and technical data.

Facts and finishes | from page 62

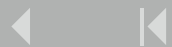

A trailblazer is always miles ahead



There is sophisticated driving, and then there is perfection. The latter requires a much greater leap. It prompts the question: How do you create a car that sets new standards? How do you define luxury, technology and safety today? Find the answer in the new GL-Class. It's in a class of its own, yet firmly in your league.



For a perfectionist, the sound experience
begins with the tyres



Every journey in the GL-Class turns into a symphony of select and truly electrifying impressions. Thanks to the car's unique noise insulation you can savour each nuance of every moment on the road. That's what we call true driving pleasure.





A leader, moving in exemplary fashion
on every terrain

The new GL-Class' refinement is full of ambition: powerful engines, serene handling, supported by countless innovative electronic assistants. The moment you hit the accelerator, a whole new world of driving dynamics presents itself. It's a new sense of elevation.



Protector. Its own sensitivity is its strength



Even in difficult road situations the new GL-Class helps you stay focused, and ahead of the game, thanks to the new standard Crosswind Assist. The most comprehensive standard safety equipment in its class provides a lot more than optimum protection: it exudes pure confidence. → Pages 22, 26–29





A beacon of style

The new GL-Class is a master of attraction. Instinctively the eye is drawn towards the striking lines of the exterior, from the characteristic front grille with the striking bi-xenon headlamps and the muscular side skirts to the powerful rear section. There is authority in its stance, just as there is in its performance.





A true individual.
Turns the smallest detail into a grand celebration

In the GL-Class, the extraordinary becomes ordinary, even the smallest detail is elevated to a special status. As if by magic the front passengers are seated in their individual position courtesy of the fully automatic front seat adjustment. The sophisticated rear seat entertainment system ensures even the longest journey is as enjoyable as possible. So wherever you are in the new GL-Class, whether you travel on or off road, it meets the highest demands. → Pages 30, 35

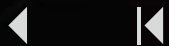

The image shows the front interior of a Mercedes-Benz GL-Class. The driver's seat is in the foreground, featuring beige leather with a perforated pattern and diamond stitching. The center console has a gear shifter and handbrake. The dashboard and door panels are dark with wood trim. The steering wheel is visible in the background. The car is parked outdoors, with a building and sky visible through the windows.

Personality in every detail

The new GL-Class is designed to grant your every wish. While luxury comes as standard, there are plenty of additional options to suit your individual needs. Whether it's the convenient access, the comfortable high seating position, luxury automatic climate control or Anthracite Poplar wood trim (shown here), you'll experience maximum comfort and wellbeing from start to finish. → Pages 30, 31



Iconic status.
A brilliant impression that never fades



Mature, responsible, yet full of excitement

Top impression, low emissions – the new GL-Class knows how to combine a thrilling performance with sustainable thinking. Economical engines, improved aerodynamics and an efficient 7G-Tronic Plus automatic transmission all play their part.

→ Pages 20–21

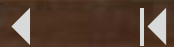

A great equaliser tames the meanest spirits

Imagine being thrown against a wall at 180mph, and enjoying it. Plough through a dried-up river bed, and call it a massage? Blast through a great canyon at scorching temperatures and think of it as a walk in the park? This ruffian simply loves causing a stir: the wilder the setting, the better. It's part of its *raison d'être*. It snatches newspapers out of your hands, turns umbrellas into ragged antennae or tears off roofs when in a particularly rotten mood.

Then again, this wayward behaviour runs in the family, with opposing parental forces applying immense pressures on their offspring. Just imagine this supernatural battle of the titans where unimaginable powers clash, throwing our rebel out of its cradle.

Let's be honest: aren't you glad your Crosswind Assist keeps this evil spirit at bay?

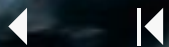

16 Mercedes-Benz Intelligent Drive**17 BlueEFFICIENCY in the GL-Class****18 Diesel engine**

6-cylinder engine

19 Petrol engine

AMG V8 engine

20 Transmission

7G-Tronic Plus automatic transmission

Direct Select

22 Suspension

Crosswind Assist

Trailer Stability Assist

Active Curve System

AirMATIC air suspension

Direct Steering

Permanent four-wheel drive

Off-road switch

On- & Off-Road Package

Downhill Speed Regulation (DSR)

26 Integrated safety concept

Attention Assist

Active Lane-Keeping Assist

Active Blind Spot Assist

Night View Assist Plus

Distronic Plus

Pre-Safe® anticipatory safety system

Collision Prevention Assist

Pre-Safe® Brake and BAS Plus

Active Bonnet

Restraint systems

Mercedes-Benz Emergency Call System

Rescue assistance

30 Seats

Electrically adjustable seats

Memory Package

31 Climate control

Automatic climate control

Luxury automatic climate control

Heated multi-function steering wheel

Temperature-controlled cup holder

32 Load compartment

Through-loading feature

Easy-Entry system

Easy-Pack powered tailgate

34 Lighting

Intelligent Light System

Fibre optic LED rear tail lights

Ambient lighting

35 Multimedia systems

COMAND Online system

Harman Kardon® Logic 7®

surround sound system

Bang & Olufsen BeoSound AMG

surround sound system

Rear seat entertainment system

36 Electronic assistants

Parking Package

Parktronic with Active Park Assist

Reversing camera

Speed Limit Assist



38 GL 63 AMG

Exterior
Interior

42 Standard equipment**43 Optional extras****44 GL 350 BlueTEC AMG Sport**

Exterior
Interior

48 *designo* Exclusive upholstery**50 Upholstery and trim****56 Alloy wheels**

Standard wheels
Optional wheels
Retailer-fit wheels

58 Retailer-fit accessories**60 Services**

Test drive
Mercedes-Benz Finance and Insurance
Interactive Owner's Manual
Roadside Assistance and
Accident Management
Service Care
Mercedes-Benz World

62 Dimensions**63 Load compartment****64 Technical data****65 Paint finishes**

Mercedes-Benz Intelligent Drive – a new era in mobility

Our engineers focus on the future every day in order to make innovative technology a reality. This aspiration has resulted in developments with a lasting impact on automotive engineering. In other words, our work ensures that a Mercedes-Benz will always be ahead of its time.

We have developed one groundbreaking solution after another to get closer to realising our vision of safe and accident-free driving. Innovative technologies such as the Pre-Safe® anticipatory safety system and Distronic Plus radar-assisted cruise control first made it onto the road in a Mercedes-Benz, setting new standards in vehicle safety. It marked the first time active and passive systems were combined – for even better protection and ride comfort.

Mercedes-Benz Intelligent Drive takes things a step further by intelligently combining sensors with safety systems and electronic assistants. For us, it's a logical progression as the traffic situation has changed. There are more vehicles on the road, the driver's job is becoming more complex and distractions are increasing.

Once again, we have revolutionised the car to provide even more assistance and to help deal with road situations effectively: today, a Mercedes-Benz has an even greater spatial awareness. It has a better view of the road and other road users, and it can react to what it sees.

We have developed a stereo camera system that is capable of capturing three dimensions. Together with further sensors, this produces a 360° view – a precise image of the surroundings. If the safety systems and electronic assistants detect danger, they can respond within a fraction of a second to provide the driver with the right assistance for the situation in hand. For example, by performing an emergency braking manoeuvre in dangerous situations, or by dimming part of the main beam for the benefit of oncoming traffic.

Pioneer of innovation – Mercedes-Benz Intelligent Drive once again underlines our leading ambition and points the way ahead to accident-free and autonomous driving. The following pages include further information about our safety and comfort systems. They are available as standard equipment or optional extras for the GL-Class, depending on the model specification. Further details can be found on pages 34–37, 42–43, and 58–59.



BlueEFFICIENCY – fast forward to tomorrow

Pure comfort, complete peace of mind: the GL-Class demonstrates that efficiency and SUV driving can go hand in hand by lowering both emissions and fuel consumption.

Mercedes-Benz is quicker at getting future technologies to where they matter most: on the road. With ever more efficient vehicles and a production process that wastes fewer and fewer resources. We call this comprehensive approach BlueEFFICIENCY. By way of example, BlueTEC technology for the diesel engine reduces nitrogen oxide

emissions by up to 90%. Our Hybrid models featuring an intelligent combination of internal combustion engine and electric drive can reduce fuel consumption significantly, while the SLS AMG Coupé Electric Drive takes electric mobility to a new level.



- 1 Air-conditioning compressor feature
- 2 New generation direct injection petrol engine and diesel engine with BlueTEC technology
- 3 Adjustable radiator shutters for intelligent cooling management
- 4 Optimised 7G-Tronic Plus automatic transmission
- 5 Energy-saving ancillaries (petrol pump and Direct Steering)
- 6 Optimised aerodynamics featuring best drag coefficient in its segment of 0.35 (underbody guard, roof spoiler, exterior mirror housing, wheel spoiler)
- 7 Driver information for fuel-efficient driving
- 8 ECO start/stop function
- 9 Intelligent alternator management with brake energy recovery
- 10 EU5 emissions standard for petrol engine, EU6 for BlueTEC diesel engine
- 11 Reduced kerb weight despite increased equipment
- 12 Tyres with lower rolling resistance, aerodynamic wheels

Diesel engine

Powerful, clean and efficient: the BlueTEC diesel engine in the new GL-Class offers the best of both worlds.

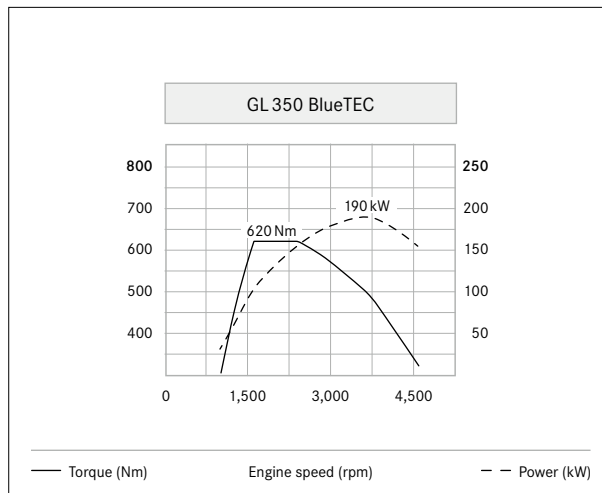

The GL 350 BlueTEC's maximum 620 Nm torque is available from 1,600 to 2,400 rpm

6-cylinder diesel engine. The third-generation common-rail system provides the key to the V6 diesel engine's efficiency, producing 190 kW (258 hp). Precise and fast piezo injectors, increased pressures of 1,600 bar and a turbocharger with variable turbine geometry help generate a mighty 620 Nm of torque.

The diesel engine already meets the EU6 emissions regulations thanks to further improved BlueTEC technology and diesel particulate filters that clean and treat the exhaust gases. In addition, the ECO start/stop function which temporarily switches off the engine at a traffic light or in a traffic jam, helps reduce fuel consumption. The standard ECO display keeps the driver informed about efficiency and encourages an economic driving style.

An intelligent alternator enables kinetic energy to be recovered during coasting and braking whilst a radiator shutter reduces drag when the engine requires less cooling. Also, low-resistance tyres, intelligent on-demand ancillaries as well as improved aerodynamics all contribute to further increase the efficiency of the GL-Class.



Petrol engine

Here's how to create the perfect balance between driving pleasure and efficiency in an SUV. Our newly-developed petrol engine offers plenty of pulling power whilst reducing fuel and emission levels.



The GL 63 AMG ensures great response and pulling power in every situation

8-cylinder petrol engine. The AMG 5.5-litre biturbo V8 offers high-powered SUV driving at its best, delivering 557 hp (410 kW) plus a maximum 760 Nm of torque. The GL 63 AMG sprints from 0 to 62 mph in just 4.9 seconds and goes on to an electronically-limited top speed of 155 mph. The GL 63 AMG offers the first chance to enjoy motor racing technology in the GL-Class, complete with characteristic sound. Its impressive efficiency is achieved by spray-guided direct petrol injection, twin turbochargers, variable camshaft control and ECO start/stop.



Transmission

The improved 7-speed 7G-Tronic Plus automatic transmission is carefully matched to the GL-Class BlueTEC engine, automatically adapting to different conditions and individual driving styles. The Direct Select steering column gear shift lever further enhances convenience.

7G-Tronic Plus. The new GL 350 BlueTEC AMG Sport is fitted with 7-speed automatic transmission and a Direct Select steering column gear shift lever as standard. The seven forward gears allow for ideally spaced ratios and ensure noticeably lower fuel consumption. Especially when driving in urban traffic, the ECO start/stop function which automatically switches off the engine when at a standstill, helps to save fuel. In kickdown, 7G-Tronic Plus can also skip individual gears for a more rapid response, jumping from seventh to fifth when overtaking for instance, while the extremely short shift times help to further enhance performance, giving you better off-roading, climbing and towing ability.

Direct Select. The GL-Class comes with our intuitive and ergonomic Direct Select steering column gear shift lever. Just tap the lever to switch between P, N, R and D and your input is transmitted electronically to the automatic transmission. Or, if you'd prefer to determine the shift points yourself, simply use the steering wheel gear shift paddles.



Transmission operation with the Direct Select lever: you can also control gear changes via the gear shift paddles on the steering wheel



7G-Tronic Plus: over 18 million automatic transmissions have found their way into a Mercedes-Benz in more than 50 years



Suspension

Designed for an engaging driving experience, the GL features permanent four-wheel drive ensuring excellent traction and stability on difficult surfaces on or off-road.

Crosswind Assist (standard). The GL-Class is the first model in its segment to be fitted with Crosswind Assist as standard. It automatically reduces the effects of sudden gusts of crosswind. A braking manoeuvre on the side of the car facing the wind helps to keep the car in lane. The Adaptive Brake system uses data supplied by sensors of the Electronic Stability Programme (ESP®), the AirMATIC air suspension as well as the Electronic Power Steering (EPS®).

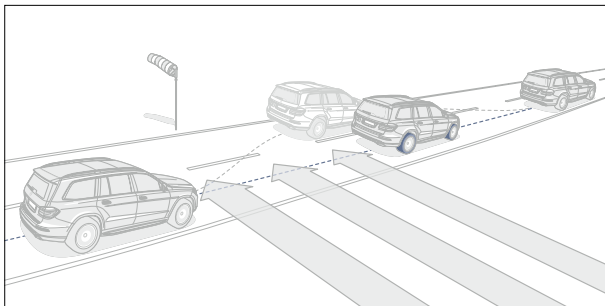

A great asset when overtaking lorries or crossing bridges: Crosswind Assist initiates braking manoeuvres to improve driving performance when required

Trailer Stability Assist (standard with optional tow bar). The ESP® sensors provide further assistance in difficult driving situations, including tow bar stabilisation when combined with the tow bar. The system detects if the trailer starts to sway and initiates short braking manoeuvres to quickly stabilise the trailer.

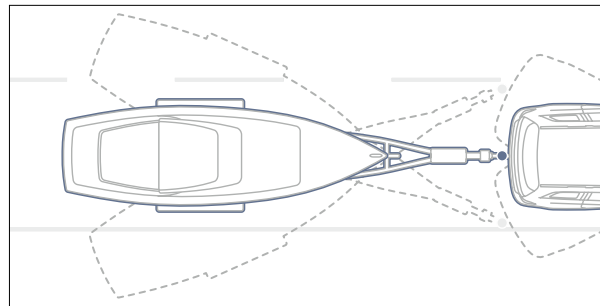

Trailer Stability Assist improves driving conditions in conjunction with ESP® sensors

Active Curve System (optional; standard on GL 63 AMG). With its active suspension stabilisers, the Active Curve System minimises body roll when cornering and off-roading. This helps to improve off-road ability, whilst enhancing enjoyment and comfort on country roads and increasing straight-line stability at motorway speeds. When driving off-road, Active Curve System also improves traction thanks to a higher degree of axle articulation.

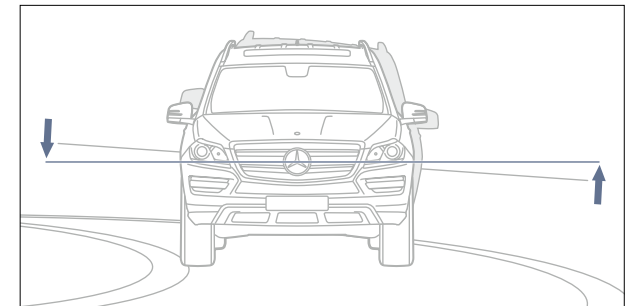

The Active Curve System reduces body roll whilst enhancing driving comfort, agility and safety



AirMATIC air suspension (standard). By adjusting the damping to suit the road surface, driving style and vehicle load, the Adaptive Damping System provides even greater ride comfort and safety on and off-road. AirMATIC air suspension allows the driver to switch manually between sporty and comfort-biased settings and, thanks to independent self-levelling, ensures the car's ride height is unaffected by heavy loads. At high speeds, the ride height is lowered by 15 mm, increasing stability, reducing drag

and thus improving fuel efficiency. Once your speed drops below 50 mph, the standard ride height is automatically reinstated. AirMATIC air suspension can also give you extra ground clearance at the touch of a button, allowing you to increase the ride height by 75 mm (or to 105 mm if the optional On- & Off-Road Package is fitted) when tackling rough terrain; and allows a clearing of up to 500 mm in the highest off-road mode (600 mm with the optional On- & Off-Road Package).

Direct Steering (standard). By adopting a more direct steering ratio in tight turns or when parking, Direct Steering significantly reduces the amount of steering input required. As your speed increases, the level of assistance decreases, helping to maximise straight-line stability in faster driving, while giving you more feel and greater precision.

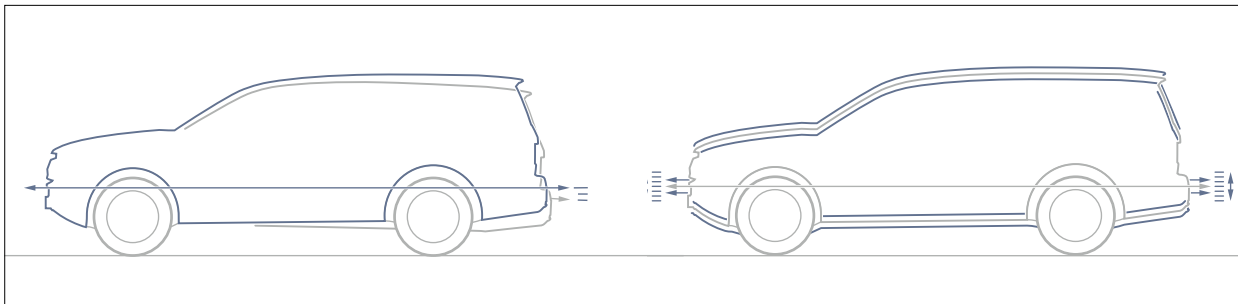

The independent self-levelling ensures the ride height is unaffected by heavy loads

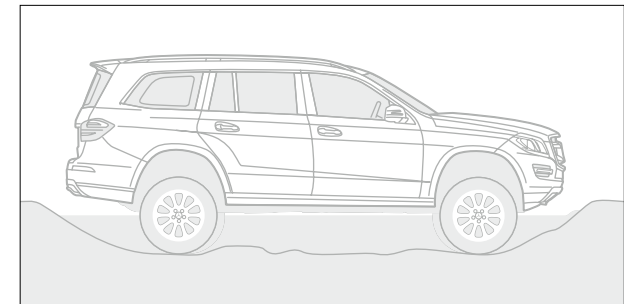

With a fording depth of 500 mm (600 mm with the optional On- & Off-Road Package), the GL-Class masters river beds and rocky terrain beautifully

Suspension

Together with permanent all-wheel drive, the chassis of the new GL-Class provides the best possible traction and enhanced driving stability even in poor road conditions and during off-road driving.

Permanent four-wheel drive (standard). On- or off-road, the permanent four-wheel drive system offers dynamic handling and optimum stability. Being always on, it is able to respond almost instantaneously in the wet or on ice or snow. It is ably assisted by the Electronic Stability Programme (ESP®) and the Four-Wheel Electronic Traction System (4ETS), which incorporates the anti-lock braking system (ABS) and Acceleration Skid Control (ASR). 4ETS directs the torque away from any spinning wheels and towards those with better traction, allowing the car to pull away more smoothly and accelerate more powerfully, especially on poor surfaces.

Off-road switch (standard; not available on GL 63 AMG). The off-road switch further enhances the off-road ability of your GL-Class, making changes to the engine management and automatic transmission as well as to safety systems such as ABS, ESP® and 4ETS. It can be activated simply by pressing a button in the centre console.

On- & Off-Road Package (optional; not available for GL 63 AMG). With the On- & Off-Road Package, you can tailor the car's set-up to suit the surface and situation by selecting one of six driving modes: 'Auto' (standard mode), 'Off-Road 1' (for sandy or less challenging

terrain), 'Off-Road 2' (for rougher terrain), 'Sport', 'Snow' and 'Towing'. These preprogrammed modes alter the ESP®, 4ETS and ASR parameters, as well as the engine management, transmission and steering systems, and also adjust the air suspension, damping levels and ground clearance as required. The various modes are selected via a rotary switch in the centre console, with the current mode indicated on the COMAND Online display, along with animations showing the gradient and angle of inclination. The package also includes 100% centre differential locks, a front underguard for the engine, and a reinforced guard for the entire underbody, which provides

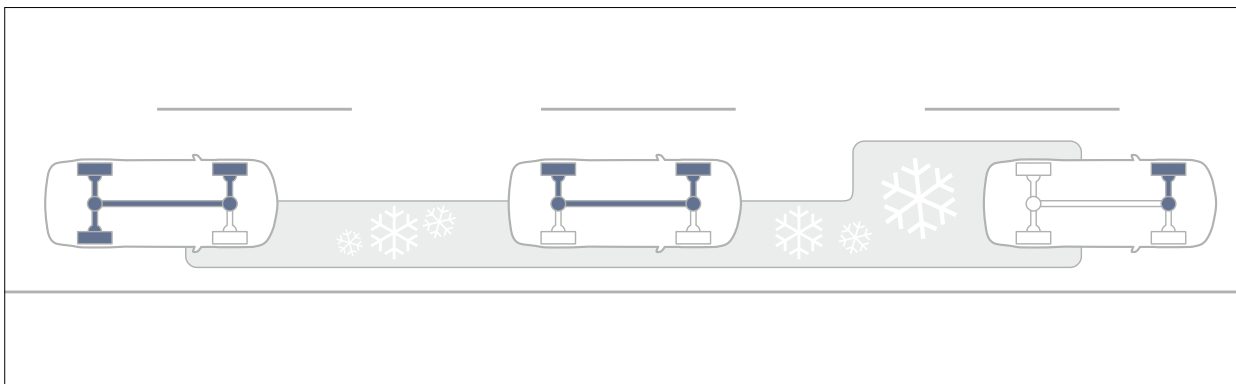

The Electronic Traction System (4ETS) automatically directs torque towards the wheels with the best traction

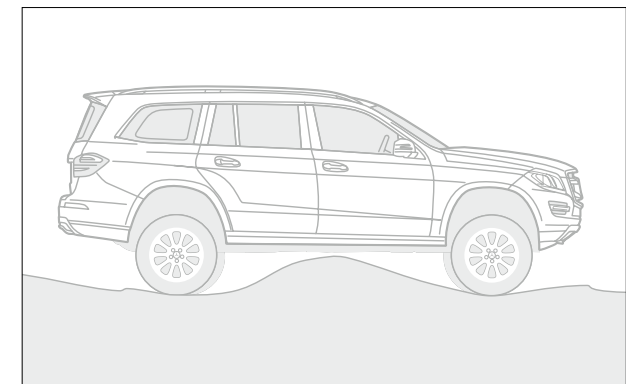

Choose your preferred driving mode via the rotary switch in the centre console

extra protection when off-roading. Other functions that can help to optimise off-road ability include a low-range ratio that enhances power, traction and stability when tackling unmade surfaces and the 7G-Tronic Plus transmission's manual mode. There are also three additional off-road modes to choose from enabling you to increase the ground clearance by 30, 60 or 90 mm with a maximum fording depth of 600 mm.

Downhill Speed Regulation (DSR) (standard). When the vehicle is negotiating steep downhill gradients, Downhill Speed Regulation allows the driver to set a speed of between 1.25 mph (2 km/h) and 11 mph (18 km/h). As far as is physically possible, the system then maintains the preset speed using the engine and transmission management and by applying the brakes as required. In this way, DSR makes for more relaxed descents and enhanced active safety in off-road driving.



Choose your preferred driving mode via the rotary switch in the centre console



The chosen mode is indicated on the COMAND Online display



Integrated safety concept

Like all our passenger cars, the GL-Class is built according to an integrated safety concept. It ensures the many passive and active protection systems work together to enhance safety in every situation – helping to bring our vision of accident-free driving another step closer.

As the inventor of the motor car, we feel a particular responsibility towards road safety. That's why we were the first manufacturer to develop an integrated safety concept that seamlessly combines a car's active and passive safety features, thus ensuring optimum all-round protection. This concept covers four different areas – safer driving, anticipating danger, protecting occupants and post-crash safety – and incorporates measures designed to maximise safety in every situation, by helping you to stay safe, alerting you to danger, and assisting you wherever possible. In addition, our unique Pre-Safe® anticipatory safety system recognises likely accident scenarios and takes steps that help to further enhance occupant protection. If a collision can't be avoided, intelligent passive safety systems help to provide protection where it's needed, while solutions that can minimise the consequences of an accident and facilitate emergency assistance are also a key part of this safety concept.

A selection of these technologies for the phases 'safer driving', 'anticipating danger', 'protecting occupants' and 'post-crash safety' are presented on the following pages.

Safer driving: Attention Assist (standard). If it detects signs of tiredness, Attention Assist alerts the driver via visual and acoustic warnings and recommends taking a break. Between speeds of approximately 50 and 110 mph, it assesses the driver's behaviour via an array of sensors and registers unexpected changes that may indicate tiredness or concentration lapses, such as involuntary movements of the steering wheel.



Particularly beneficial on long journeys, Attention Assist is an innovative system for detecting fatigue

Safer driving: Active Lane-Keeping Assist (as part of the optional Driving Assistance Package). This package comprises a range of intelligent safety technologies. Active Lane-Keeping Assist draws the driver's attention to unintended lane changes, gently vibrating the steering wheel if the car wanders across lane markings. If the driver doesn't react to the warning, the system is able to intervene in order to correct the car's course.



Active Lane-Keeping Assist alerts to inadvertent lane changes and corrects the car's course if no action is taken

Safer driving: Active Blind Spot Assist (as part of the optional Driving Assistance Package) makes intentional lane changes safer too, using twin radar sensors to watch over the areas not visible in your exterior mirrors. If the sensors spot a vehicle in one of these blind spots, a flashing red triangle appears in the corresponding mirror, accompanied by an acoustic warning from the instrument panel. Should the driver nevertheless proceed to change lanes, the system can intervene and help prevent a collision by automatically applying the brakes on the appropriate side.

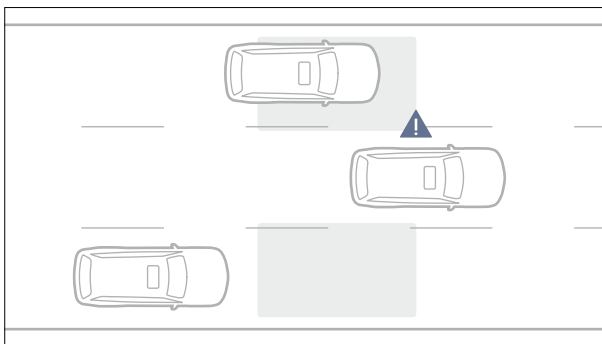

Active Blind Spot Assist alerts the driver and applies the brakes if necessary should the system detect a vehicle during lane changes

Safe driving: Night View Assist Plus (optional). The COMAND display highlights the entire area normally covered by main beam, as recorded by the Night View Assist system's infrared camera, in the form of a greyscale image. This makes it easier for drivers to get their bearings in situations where main beam cannot be switched on and allows them to react quicker to people detected on or next to the road. What's more, pedestrians detected by the system are designated on the display by the special pedestrian recognition function.



To ensure better driver awareness, Night View Assist Plus highlights pedestrians on the display

Safer driving: Distronic Plus (as part of the optional Driving Assistance Package). This radar-assisted cruise control enables the car to automatically maintain a preset distance from the vehicle in front, both in high-speed driving and in stop/start traffic. It works with the Pre-Safe® Brake system which initiates an emergency brake 0.6 seconds before an unavoidable collision, thus lessening the impact. Meanwhile, Brake Assist (BAS Plus) provides the brake force to suit the situation.

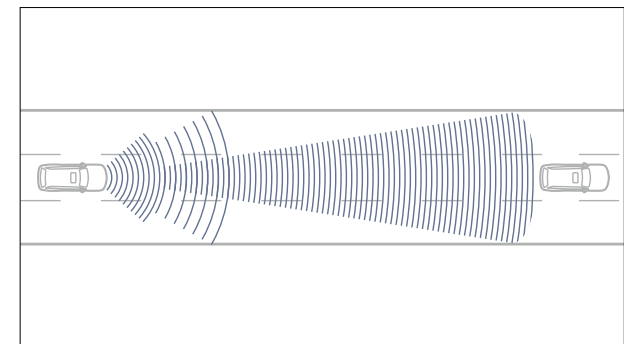

Distronic Plus helps reduce the speed in slow traffic to a standstill and automatically accelerates to resume the journey

Anticipating danger: Pre-Safe® system (standard). If it detects a probable accident scenario, Pre-Safe® anticipatory safety system can take a range of anticipatory measures to protect the occupants. These can include activating the front seat belt tensioners and automatically closing the windows and sunroof (if fitted), ensuring maximum protection from airbags and seat belts should an impact then occur. In addition, the optional memory function enables the front passenger seat to be moved to a safer position in an accident. If a collision is avoided, the seat belt tension is released, all other components can

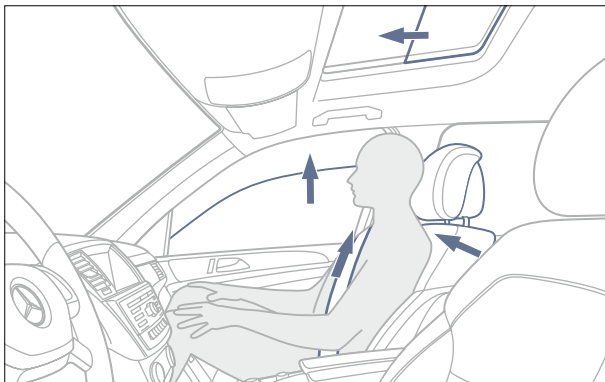

Pre-Safe® anticipates dangerous situations and takes appropriate measures to protect the occupants

be returned to the desired positions, and the Pre-Safe® system reverts to standby.

Anticipating danger: Collision Prevention Assist

(standard). Collision Prevention Assist can alert the driver if the distance to the vehicle in front decreases with unusual rapidity, thereby helping to avoid front-end shunts. The radar-assisted warning system works from speeds around 20 mph. When the brakes are then applied, the Adaptive Brake Assist function can automatically increase the brake force if necessary, ensuring the available stopping

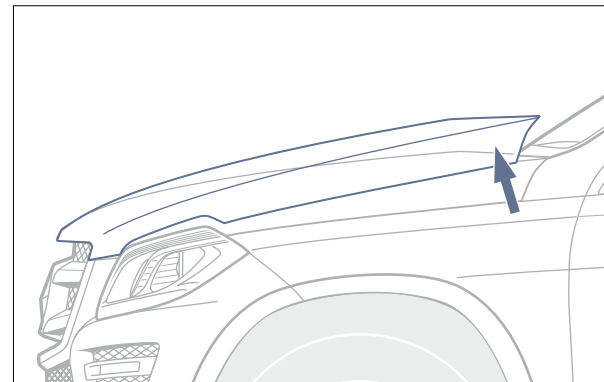

Active Bonnet helps reduce the risk of injury to pedestrians and cyclists in a collision

distance is exploited to the full and thereby increasing the chances of avoiding an impact.

Anticipating danger: Pre-Safe® Brake and BAS Plus

(as part of the optional Driving Assistance Package). If the Pre-Safe® Brake detects a probable collision, it alerts the driver with visual and acoustic warnings, whilst BAS Plus calculates the required brake force to avert an accident. If the driver's action is not sufficient, the system increases the brake force automatically. Should the driver fail to react to the acoustic warning, the system initiates a short brake autonomously to warn the driver. If there is still no reaction from the driver, the system automatically performs an emergency brake.

Protecting occupants: Active Bonnet (standard; not available for GL 63 AMG). The Active Bonnet system can reduce the risk of injury to pedestrians and cyclists in a collision. If sensors in the front bumper detect an impact, they trigger a spring mechanism that raises the bonnet slightly. The extra space this creates between the comparatively soft bonnet and the hard components beneath can help to absorb some of the impact energy and thereby reduce the risk of severe injuries.

Protecting occupants: restraint systems (standard).

The GL-Class is fitted with seven airbags to ensure optimum occupant protection, with dual-stage airbags for the front seats, sidebags (combined thorax/pelvisbags) for driver and front passenger, windowbags over both rows of seats and a kneebag for the driver. Sidebags for the second row are available as an option.

Post-crash safety: Mercedes-Benz Emergency

Call System (part of COMAND Online system). The system can automatically send an emergency call via an operational telephone connected to the vehicle, as soon as the restraint system detects a crash. The GPS position data and information about the car are sent to the Mercedes-Benz emergency call centre and a speech connection is then set up. The emergency call can also be triggered manually.

Post-crash safety: rescue assistance. Mercedes-Benz has developed a range of measures that help to minimise the secondary consequences of an accident and facilitate occupant rescue. These include automatic engine cut-off, self-activating hazard lights and emergency cabin lighting. In addition, the central locking system is automatically released in the event of an accident, and there are special crash joints between the front doors and wings that make it easier to open the doors after frontal collisions. In addition, Mercedes-Benz provides a rescue guide for emergency services that can be downloaded from the Internet at www.mercedes-benz.co.uk/rescueguide

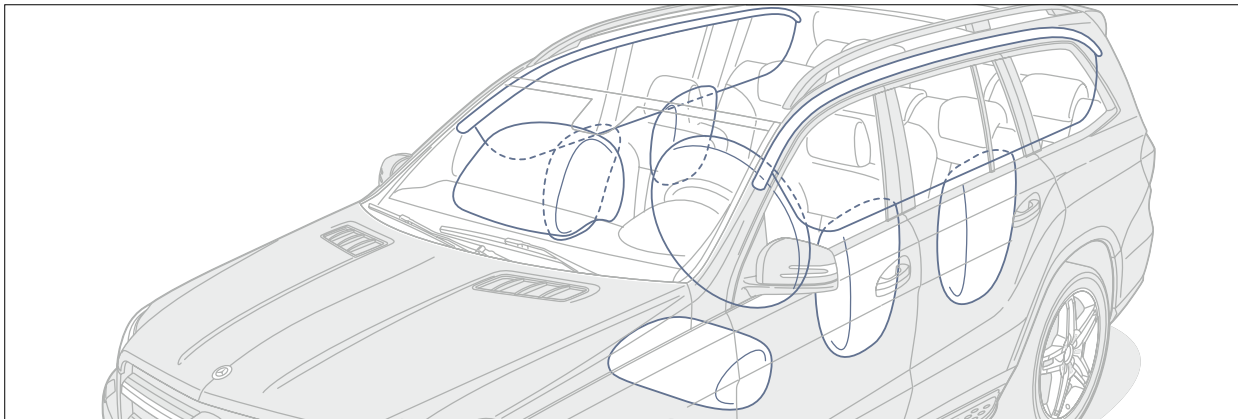

Seven airbags help to significantly reduce the risk of injury in a collision

Seats

Expect long-distance comfort and premium interior atmosphere from rows one to three in the new GL-Class.



Electrically adjustable seats (standard). Up to seven passengers enjoy the highest level of comfort thanks to the spacious interior and the highly ergonomic seats which offer excellent support. The driver and the front passenger seat feature full electric adjustment, with intuitive and conveniently positioned controls in the door panels. Both front seats are heated, whilst the second row seats are heated as an option (standard on GL 63 AMG). For additional convenience, the GL-Class front seats can be fitted with comfort ventilation in conjunction with leather upholstery. The GL 63 AMG also offers multi-contour front seats with massage function, luxury head restraints and seat cushion depth adjustment as standard.

Memory Package (optional; standard on GL 63 AMG). For luxurious seating comfort, individual settings for front seats, front head restraints, steering column and exterior door mirrors can be electrically adjusted and stored. The package also includes four-way electric lumbar support for the front passenger seat.

In the GL-Class, you are welcomed by premium materials and expert craftsmanship



Climate control

A relaxed driver is a better driver. Which is why the GL-Class offers a wide range of climate options to suit individual needs

Automatic climate control (standard on GL 350 BlueTEC AMG Sport). Automatic climate control allows the driver and front seat passenger to select separate temperature and blower settings and maintains these automatically. It also includes an air recirculation function, a chilled glove compartment, twin air vents for the rear passenger compartment, and a cabin air filter that captures particulates.

Luxury automatic climate control (optional; standard on GL 63 AMG). With luxury automatic climate control, the

driver, front passenger and rear seat passengers can set separate temperatures for each of the three cabin zones. The system features separate controls and air vents and a booster blower for rear seat passengers, plus additional vents in the B-pillars, and offers individually adjustable settings even in automatic mode. Luxury automatic climate control is also optionally available for the rear seats. It offers separate heating and ventilating controls via four additional air vents for the best climate control throughout all three rows.

Heated multi-function steering wheel (optional). The rim of this steering wheel will heat up to a temperature of 35°C, making it a pleasure to hold even in cold weather.

Temperature-controlled cup holders (optional). This feature keeps drinks at their desired temperature for longer, whether hot or cold. The cupholders offer a temperature range of between 8 and 55°C, for maximum enjoyment whatever the season.



Intuitive, effective and easy to use, the quiet luxury automatic climate control system responds rapidly for optimum heating and ventilation



The temperature-controlled cup holders keep hot drinks warm and cold drinks chilled, while also holding them securely in place

Load compartment

The new GL-Class seats up to seven occupants comfortably. Ample loading space and flexible load management make this SUV a truly generous vehicle.

Even with seven occupants on board, the GL-Class still offers 295 litres of luggage capacity (measured up to top edge of rear backrest) or 390 litres if loaded to roof height. Should you require more space, folding the second rear seat forward gives you a total luggage capacity of 680 litres loaded to the edge of the rear seat and 1,320 if loaded to roof height. For added versatility, the second row rear seat splits $\frac{1}{3}:\frac{2}{3}$ and folds forward.



The GL-Class load capacity can be managed according to your needs

With all rear seats folded, 2,300 litres of luggage space with an almost completely flat cargo area are available to you. The maximum load length of around two metres offers plenty of options, while loose or awkward-shaped items can be secured with six rings on the load compartment floor. There is also a foldable bag hook on the side, while clothes hooks are situated on the inside of the tailgate and on the handles above the rear side windows.



Room for four occupants, and a two-metre load capacity

The tailgate itself lifts to an impressive 1.95 metres from the ground, helping to avoid knocks to the head when loading and unloading. Additionally, the Easy-Pack load compartment cover protects your cargo against UV rays and unwanted attention.



The load compartment of the new GL-Class is among the largest in its class



Through-loading facility (optional). The rear centre armrest can be fitted with an optional through-loading facility that is particularly useful for transporting skis. This quick and easy to use feature allows two rear seat passengers to travel in comfort even with skis onboard.



The rear centre armrest with handy through-loading facility¹

Easy-Entry system (standard). For easier third row rear seat access on either side, the seats in the second row feature Easy-Entry system. The 1/3:2/3 split second row seats can simply be folded forward by applying a lever on the side. For added convenience, an optional Easy-Entry system feature performs the folding electrically at the touch of a button: the headrests move down, the back rests fold down and the seats fold forward.

Easy-Pack powered tailgate (standard). The Easy-Pack powered tailgate can be operated remotely either via the switch in the driver's door or the remote control. It can also be opened by simply touching the tailgate handle, or manually using the external tailgate release, and closed by pushing a button on the inside of the tailgate. In addition, the tailgate can be stopped at any position, to prevent it from hitting a low garage ceiling for instance, and features an obstruction sensor which automatically reverses the direction of travel if it detects an obstacle.

¹Image shows optional *designo* Exclusive leather upholstery (diamond design for GL 350 BlueTEC AMG Sport only)



Lighting

To see and be seen: in the GL-Class that's not just a question of safety, but also a question of striking design.

Intelligent Light System (standard). The Intelligent Light System features bi-xenon headlamps with five modes and functions to suit different road situations: country mode, motorway mode, fog mode, cornering light function and the Active Light System for better visibility in bends. It also includes LED daytime running lights and Adaptive High Beam Assist, which maximises the headlamps' range when no other road users are within sight, then automatically dips the beams if the lights of an oncoming vehicle are detected.



The Adaptive High Beam Assist automatically maximises the headlamps' range to suit the road situation

Fibre optic LED rear tail lights (standard). The fibre optic LED rear tail lights emphasise the striking rear section of the new GL-Class. They are significantly robust, energy efficient and long-lasting. Whilst the tail-light and the side marker light come with LED fibre optic technology, the indicator features LEDs, and the brake light, reversing and fog lamp are fitted with conventional bulb technology.



Truly outstanding: rear lights with fibre optic LED technology

Ambient lighting (optional). The instrument panel and door panels can be fitted with interior lighting to create a unique and warm atmosphere at night. The interior lighting features three colour settings, neutral (white), solar (amber) and polar (blue), which can be dimmed seamlessly to suit your individual taste.



The interior lighting creates a stylish atmosphere and aids orientation on board at night



Multimedia systems

The new GL-Class can be fitted with a wide range of entertainment and navigation options – from COMAND Online through to rear seat entertainment system.

COMAND Online system (standard). The multimedia system plays your audio and video DVDs, your CDs and even your MP3 files. It features a single CD player as well as a tuner, an equaliser with speed-sensitive volume adjustment, an SD card slot, USB port, aux-in socket, iPod® connectivity, Bluetooth® and a 10 GB music register that can be operated using a separate remote control. Also included are hard disk-based navigation with optimised map graphics and free European map updates for three years (for the one vehicle from its first registration) and in-car Internet access (Internet mobile phone needed). COMAND Online is operated via an intuitive and easy-to-reach controller in the centre console, buttons on the multi-function steering wheel or Linguatronic voice control – with all the functions and information shown on the central 7-inch display.

Harman Kardon® Logic 7® surround sound system (optional). With 14 high-performance speakers and an 830-watt output, the surround sound system brings high-end audio to your GL-Class. It also comes with speed-sensitive volume adjustment, ensuring the best listening experience at all times.

Bang & Olufsen BeoSound AMG surround sound system (optional). Perfect acoustics meets pure style – courtesy of the Danish sound specialist: This high-end sound system offers 14 high-performance speakers with a total output of 1,200 watts and combines it with exclusive design. The grilles of the subwoofer in the parcel shelf and the mid-range and tweeter units in the front and rear doors are of solid brushed aluminium.



The multimedia system can be managed via the central 7-inch colour display

Rear seat entertainment system (optional). The rear seat entertainment system gives rear seat passengers everything they need to watch films or use a games console without disturbing the driver. It comprises a DVD player, two 8-inch TFT colour displays that attach to the backs of the electric front seat head restraints and can be used independently of one another, two sets of wireless headphones, a remote control and twin aux-in sockets. A TV tuner that brings broadcast television to the GL-Class can be fitted as a separate option.



The rear seat entertainment system colour displays are attached to the backs of the head restraints

Electronic assistants

The GL-Class offers a wide range of helpful assistants for more effortless and safer driving.



The bird's eye view offers a 360° image of your immediate surroundings to help you manoeuvre your GL-Class

Parking Package (optional). The Parking Package combines Parktronic with Active Park Assist and a 360° camera. Four cameras capture a 360° bird's eye view of the car's immediate surroundings and relay it to the centre console display. The cameras are situated on the front grille, in the wing mirrors and on the tailgate, covering an area of up to three metres surrounding the car. Obstacles below the beltline are shown in the display to help navigate near the kerb, when reversing; guiding lines are also displayed. As a result, overall vision is highly improved off-road, and when parking and manoeuvring your GL-Class. The system alerts the driver with visual and acoustic warnings. It also allows you to choose and separately display images of the individual cameras.



Parktronic with Active Park Assist (standard). With Active Park Assist, your GL-Class can identify suitable parking spaces and even manoeuvre itself into them. Once you've come to a standstill, accepted the proposed space and engaged reverse, the system steers you in automatically, leaving you to simply operate the accelerator and brakes as required. The system evaluates signals from Parktronic's ten ultrasonic sensors, using them to measure the distance to the vehicles in front and behind and thus calculates the ideal entry angle.



Active Park Assist completes the parking manoeuvre in a maximum of five moves

Reversing camera (optional). This wide-angle camera makes for safer and easier parking manoeuvres, capturing the area immediately behind the car and displaying the image on the COMAND Online display. The camera is activated automatically as soon as the driver engages reverse.



The COMAND Online system's centre console display shows the area behind the GL-Class when reversing

Speed Limit Assist (standard, part of COMAND Online system). Thanks to a windscreen-mounted camera that permanently scans the car's surroundings, Speed Limit Assist can recognise speed limits and display them in the instrument panel. Particularly useful in areas where the legal limit varies or when passing through roadworks, the system is also able to compare speed limit signs with data from the navigation system.



Speed Limit Assist alerts you to the current legal limit on the instrument panel and in COMAND Online's central display

GL 63 AMG Exterior

There are many ways to maximise power. The GL 63 AMG shows how it's done. It features AMG bodystyling as well as AMG door sill panels, AMG sports exhaust system, 21" AMG 5-twin-spoke alloy wheels in Titanium Grey, and 'V8 BITURBO' lettering on the front wings. The V8-model also features a wide range of electronic assistants, including Active Curve System with AirMATIC air suspension, Intelligent Light System, Mirror Package, and Parktronic with Active Park Assist.



Exterior

Active Curve System and AirMATIC air suspension

Aluminium-finish running boards with rubber studs and LED illumination

AMG bodystyling

AMG high-performance braking system with silver-painted brake calipers

AMG sports exhaust system with two chromed twin tailpipes

Electric glass sunroof

Flared wheel arches with 21" AMG 5-twin-spoke alloy wheels painted Titanium Grey

Intelligent Light System

Mirror Package

Parktronic with Active Park Assist

Privacy glass

'V8 BITURBO' lettering on front wings



Optional *designo* floor mats shown







GL 63 AMG Interior

The V8-model carries the unmistakable AMG signature in all the key places: on the performance steering wheel, the sports seats with leather upholstery and on the floor mats. For the highest level of comfort, the GL 63 AMG features luxury automatic climate control and multi-contour seats with massage function and Memory Package, plus heated front and second row seats.



Interior

AMG brushed stainless steel sports pedals with rubber studs and AMG floor mats

AMG Performance steering wheel – 4-spoke multi-function, trimmed in nappa leather with perforated grip areas, flattened bottom section and silver-coloured gear shift paddles

AMG sports seats with AMG-specific seat design upholstered in leather

COMAND Online system with single-disc changer and Media Interface

Front and second row seats heated

Luxury automatic climate control

Memory Package and multi-contour front seats with massage function

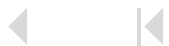

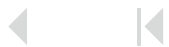

Standard equipment | Selection



LED daytime running lights



Aluminium finish, LED-illuminated running boards



Intelligent Light System



Easy-Entry system – third seat row, left and right¹



Electric glass sunroof, chrome-effect roof rails



Electrically-adjustable front seats



Parktronic with Active Park Assist



COMAND Online with Media Interface



Optional extras | Selection



Panoramic glass sunroof¹



On- & Off-Road Package²



Rear seat entertainment system¹



Luxury automatic climate control³



Keyless-Go³



Temperature-controlled cup holder



Harman Kardon[®] Logic 7[®] surround sound system



Bang & Olufsen surround sound system

¹Optional *designo* Exclusive leather upholstery shown (diamond design on GL 350 BlueTEC AMG Sport only) ²GL 350 BlueTEC AMG Sport only ³Standard on GL 63 AMG



GL 350 BlueTEC AMG Sport Exterior

If you're looking for sophistication, the GL 350 BlueTEC AMG Sport is the answer. The exterior makes a strong impression with AMG bodystyling, metallic paint and 21" AMG 5-twin-spoke alloy wheels. Chrome-effect roof rails, aluminium-finish running boards with rubber studs and LED illumination complete the sporty appearance. An electric glass sunroof is also part of this striking model. Of course, this GL-Class has plenty of room for smart technology: AirMATIC air suspension, Intelligent Light System as well as Parktronic with Active Park Assist are all standard on this diesel model.

Exterior

19" sports brakes with perforated front discs and brake caliper covers with 'Mercedes-Benz' lettering

AirMATIC air suspension

Aluminium-finish running boards with rubber studs and LED illumination

AMG bodystyling

Electric glass sunroof

Flared wheel arches with 21" AMG 5-twin-spoke alloy wheels

Intelligent Light System

Mirror Package

Parktronic with Active Park Assist

Privacy glass



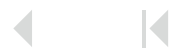



GL 350 BlueTEC AMG Sport Interior

The GL 350 BlueTEC Sport AMG welcomes you on-board with Artico¹ upholstery in Black, Almond Beige or Alpaca Grey, and brushed light aluminium trim. Automatic climate control and heated front seats complete your sense of well-being, while COMAND Online provides all the multimedia options you could wish for. The 4-spoke multi-function sports steering wheel reminds you that you're in a truly athletic SUV, and the rear seats with flexible folding options ensure the GL-Class can effortlessly accommodate up to seven occupants and plenty of luggage.



Interior

Automatic climate control

COMAND Online system with Media Interface

DAB digital radio tuner

Heated front seats

Rear seats – second seat row – split folding $\frac{1}{3}:\frac{2}{3}$

Seven seats with Easy-Entry system – left and right for third seat row

Sports steering wheel – 4-spoke multi-function, trimmed in nappa leather with perforated grip areas²

Third seat row electrically folding and raising

¹Artificial leather ²Sports steering wheel only in conjunction with light brushed aluminium trim for GL 350 BlueTEC AMG Sport







designo Exclusive upholstery

To provide the GL-Class with an even greater sense of style and individuality, opt for the *designo* Exclusive upholstery. It features leather in your chosen *designo* colour (Black, Marron or Porcelain) complete with *designo* badges in front and rear seat backrests (AMG badges on GL 63 AMG). The diamond seat design is reserved for the GL 350 BlueTEC AMG Sport. The dashboard and door beltlines are trimmed in Black nappa leather (Marron with Marron *designo* Exclusive upholstery). Floor mats with *designo* Black leather edging and *designo* metal badges, plus roof lining in black Dinamica microfibre complete the *designo* package.



Interior

Armrests in doors and centre console and handrest in chosen *designo* leather colour

Dashboard and door beltlines trimmed in Black nappa leather (Marron nappa leather with code X06)

designo Exclusive leather upholstery

designo badges in front and rear seat backrests (AMG badges for GL 63 AMG)

Floor mats with edging in *designo* Black leather and *designo* metal badges

Roof lining in black Dinamica microfibre

Seat and door centre panels in chosen *designo* leather colour (with diamond design for GL 350 BlueTEC AMG Sport only)

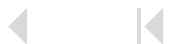



Upholstery and trim



The Black interior scheme features either Black Artico¹ (standard on GL 350 BlueTEC AMG Sport) or Black leather upholstery (standard on GL 63 AMG) for the seats and matching Black for the door centre panels, dashboard, carpets and steering wheel trim. The roof lining is in contrasting Alpaca Grey. Brushed light aluminium interior trim comes as standard (combined with a sports steering wheel on the GL 350 BlueTEC AMG Sport) while a variety of optional trims are also available.

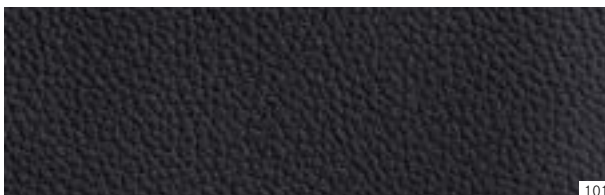

101

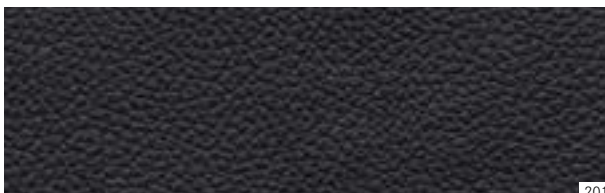

201



739



H09



734



729



731



W69

Black

101² | 201^{3,4} Artico¹/leather

Trim

739	Brushed light aluminium ^{5,6}
H09	Brown Open-pore Ash wood ^{4,7}
734	Brown Eucalyptus wood, gloss ^{4,7,8}
729	Anthracite Poplar wood, gloss ^{4,7}
731	Brown Burr Walnut wood, gloss ^{4,7}
W69	<i>designo</i> Black Piano Lacquer ^{4,7}

¹Artificial leather ²Standard on GL 350 BlueTEC AMG Sport ³Standard on GL 63 AMG
⁴Optional ⁵Standard ⁶Includes sports steering wheel on GL 350 BlueTEC AMG Sport only
⁷Sports steering wheel is replaced on GL 350 BlueTEC AMG Sport only
⁸Optional on GL 350 BlueTEC AMG Sport only





The Almond Beige interior scheme features either Almond Beige Artico¹ (standard on the GL 350 BlueTEC AMG Sport) or Almond Beige leather upholstery (standard on the GL 63 AMG) for the seats and features matching Almond Beige for the door centre panels, carpets and roof lining. The upper dashboard trim and steering wheel are in contrasting Mocha Brown. Brushed light aluminium interior trim comes as standard (combined with a sports steering wheel on the GL 350 BlueTEC AMG Sport) while a variety of optional trims are also available.

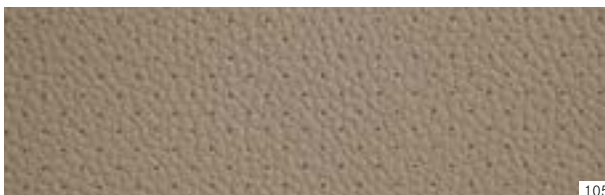

105

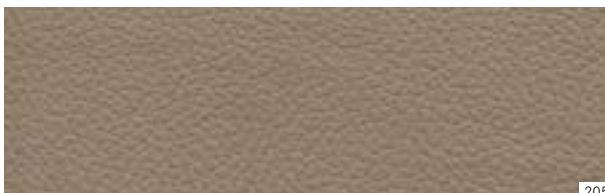

205



739



H09



734



729



731



W69

Almond Beige

105² | 205^{3,4} Artico¹/leather

Trim

739	Brushed light aluminium ^{5,6}
H09	Brown Open-pore Ash wood ^{4,7}
734	Brown Eucalyptus wood, gloss ^{4,7,8}
729	Anthracite Poplar wood, gloss ^{4,7}
731	Brown Burr Walnut wood, gloss ^{4,7}
W69	<i>designo</i> Black Piano Lacquer ^{4,7}

¹Artificial leather ²Standard on GL 350 BlueTEC AMG Sport ³Standard on GL 63 AMG
⁴Optional ⁵Standard ⁶Includes sports steering wheel on GL 350 BlueTEC AMG Sport only
⁷Sports steering wheel is replaced on GL 350 BlueTEC AMG Sport only
⁸Optional on GL 350 BlueTEC AMG Sport only





The Alpaca Grey interior scheme features either Alpaca Grey Artico¹ (standard on GL 350 BlueTEC AMG Sport) or Alpaca Grey leather upholstery (standard on GL 63 AMG) for the seats and matching Alpaca Grey for the door centre panels and roof lining. The carpets, upper dashboard trim and steering wheel are in contrasting Dark Basalt Grey. Brushed light aluminium interior trim comes as standard (combined with a sports steering wheel on the GL 350 BlueTEC AMG Sport) while a variety of optional trims are also available.



108

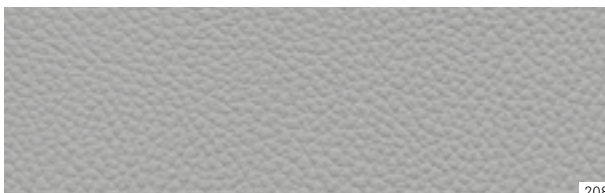

208



739



H09



734



729



731



W69

Alpaca Grey

108² | 208^{3,4} Artico¹/leather

Trim

739	Brushed light aluminium ^{5,6}
H09	Brown Open-pore Ash wood ^{4,7}
734	Brown Eucalyptus wood, gloss ^{4,7,8}
729	Anthracite Poplar wood, gloss ^{4,7}
731	Brown Burr Walnut wood, gloss ^{4,7}
W69	<i>designo</i> Black Piano Lacquer ^{4,7}

¹Artificial leather ²Standard on GL 350 BlueTEC AMG Sport ³Standard on GL 63 AMG
⁴Optional ⁵Standard ⁶Includes sports steering wheel on GL 350 BlueTEC AMG Sport only
⁷Sports steering wheel is replaced on GL 350 BlueTEC AMG Sport only
⁸Optional on GL 350 BlueTEC AMG Sport only





The optional Black/Tobacco Brown interior scheme comes with Tobacco Brown and Marron leather upholstery for the seats and features Marron door centre panels and armrests. The carpets, roof lining, upper and lower dashboard trim and steering wheel are in contrasting black. Brushed light aluminium interior trim comes as standard (combined with a sports steering wheel for the GL 350 BlueTEC AMG Sport) while a variety of optional trims are also available.

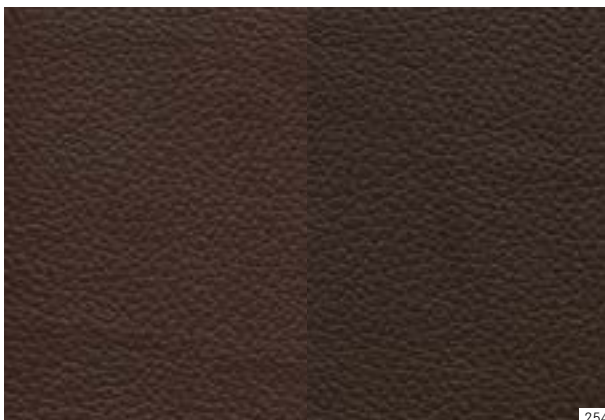

254



739



H09



734



729



731



W69

Black/Tobacco Brown

254¹ Leather

Trim

739 Brushed light aluminium^{2,3}

H09 Brown Open-pore Ash wood^{1,4}

734 Brown Eucalyptus wood, gloss^{1,4,5}

729 Anthracite Poplar wood, gloss^{1,4}

731 Brown Burr Walnut wood, gloss^{1,4}

W69 *designo* Black Piano Lacquer^{1,4}

¹Optional ²Standard ³Includes sports steering wheel on GL 350 BlueTEC AMG Sport only

⁴Sports steering wheel is replaced on GL 350 BlueTEC AMG Sport only

⁵Optional on GL 350 BlueTEC AMG Sport only





The optional Black/Almond Beige interior scheme comes with Almond Beige leather upholstery for the seats and features matching Almond Beige door centre panels. The carpets, roof lining, upper and lower dashboard trim and steering wheel are in contrasting Black. Brushed light aluminium interior trim comes as standard (combined with a sports steering wheel for the GL 350 BlueTEC AMG Sport) while a variety of optional trims are also available.

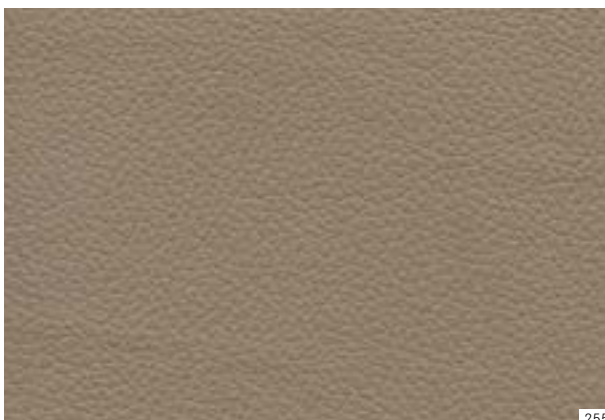

255



Black/Almond Beige

255¹ Leather

Trim

739 Brushed light aluminium^{2,3}

H09 Brown Open-pore Ash wood^{1,4}

734 Brown Eucalyptus wood, gloss^{1,4,5}

729 Anthracite Poplar wood, gloss^{1,4}

731 Brown Burr Walnut wood, gloss^{1,4}

W69 *designo* Black Piano Lacquer^{1,4}

¹Optional ²Standard ³Includes sports steering wheel on GL 350 BlueTEC AMG Sport only

⁴Sports steering wheel is replaced on GL 350 BlueTEC AMG Sport only

⁵Optional on GL 350 BlueTEC AMG Sport only





The optional Black/Alpaca Grey interior scheme comes with Alpaca Grey leather upholstery for the seats and features matching Alpaca Grey door centre panels. The carpets, roof lining, upper and lower dashboard trim are in contrasting Black. Brushed light aluminium interior trim comes as standard (combined with a sports steering wheel for the GL 350 BlueTEC AMG Sport) while a variety of optional trims are also available.

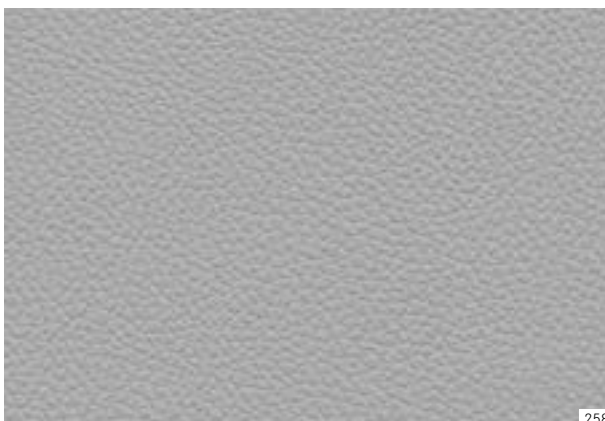

258



739



H09



734



729



731



W69

Black/Alpaca Grey

258¹ Leather

Trim

739 Brushed light aluminium^{2,3}

H09 Brown Open-pore Ash wood^{1,4}

734 Brown Eucalyptus wood, gloss^{1,4,5}

729 Anthracite Poplar wood, gloss^{1,4}

731 Brown Burr Walnut wood, gloss^{1,4}

W69 *designo* Black Piano Lacquer^{1,4}

¹Optional ²Standard ³Includes sports steering wheel on GL 350 BlueTEC AMG Sport only

⁴Sports steering wheel is replaced on GL 350 BlueTEC AMG Sport only

⁵Optional on GL 350 BlueTEC AMG Sport only



Alloy wheels



21" AMG 5-twin-spoke alloy wheel with 295/40 R21 tyres, with a high-shine finish (standard for GL 350 BlueTEC AMG Sport, code 757)





21" AMG 5-twin-spoke alloy wheel with 295/40 R 21 tyres, painted in Titanium Grey and with a high-sheen finish (standard for GL 63 AMG; code 798)



21" AMG 5-spoke alloy wheel with 295/40 R 21 tyres, painted in Titanium Grey and with a high-sheen finish (optional for GL 63 AMG, code 777)



19" 5-twin-spoke alloy wheel with 275/55 R 19 tyres, painted in Titanium Silver (Retailer-fit accessory¹)



18" 7-spoke alloy wheel with 265/60 R 18 tyres, painted in Titanium Silver (Retailer-fit accessory¹)

¹Retailer-fit accessory wheels are supplied without tyres, hubcaps or wheel bolts. Availability depends on engine type and selected equipment. For further information please contact your Retailer



Retailer-fit accessories

A Mercedes-Benz is not just a car, it's a travel companion that can be tailored to your needs – with our wide range of Retailer-fit accessories.

→ www.mercedes-benz.co.uk/accessories

Generous, flexible, practical – the new GL-Class is perfectly suited to an active lifestyle. The range of Retailer-fit accessories allows you to broaden its potential: choose between aluminium style Easy-Fix II roof rail carriers to suit the standard chrome-effect roof rails – ideal for your skis or snowboards, or the versatile Mercedes-Benz roof boxes. These robust roof boxes are available in a range of colours and sizes; their aerodynamic design matches the striking GL-Class exterior.



The roof boxes combine extra storage space with elegant, aerodynamic lines

The bright chrome fins are a distinctive addition to the bonnet of the new GL-Class and blend harmoniously with its chrome exterior trim. Designed specifically for the GL-Class bonnet vents, they come in a six-piece set that is quick and easy to fit.

The iPad® docking station enables those in the rear to use Apple tablets as safely and comfortably as possible. Not only does it allow media stored on the iPad® to be

enjoyed during the journey, it also charges the battery at the same time (available for iPad®, iPad 2 and iPad 3). What's more, with the Retailer-fit InCar Hotspot, even non-3G tablets can be connected to the Internet.



Eye-catcher: the bright chrome bonnet fins are easy to fit





The rear seat docking station allows passengers to use and charge an iPad® at the same time



Services

Test drive. Words can only do so much. Some things have to be experienced to be truly appreciated. Which is why we'd like to invite you for a test drive. Feel the power of efficient engines that offer impressive fuel consumption. Feel exhilarated by precise steering, designed to connect the driver with the road and enjoy sumptuous levels of comfort. Your Mercedes-Benz Retailer will be happy to make arrangements for you to experience the things that set a Mercedes-Benz apart. Alternatively, to request a test drive online simply visit www.mercedes-benz.co.uk/testdrive We look forward to seeing you.

Mercedes-Benz Finance. At Mercedes-Benz Finance, our single-minded aim is to provide optimum financial solutions for all those who share the Mercedes-Benz philosophy of absolute commitment to quality. Whether you are a private customer or a business user, our finance and leasing packages can be tailored to meet your individual needs. For further information on Mercedes-Benz Finance, please contact your local Mercedes-Benz Retailer.



Mercedes-Benz Insurance offers a fully comprehensive 5-star-rated¹ Motor Insurance policy specifically designed to provide the cover you would expect from Mercedes-Benz. For a quotation, please call 0845 600 2180²

Interactive Owner's Manual. The website also offers an interactive tour, enabling you to take a closer look at your desired model. This simulation is the ideal way to acquaint yourself with your dream car. You can view key functions in detail, gain an insight into the car's inner workings or look at the benefits of each model. For further details, visit www.mercedes-benz.co.uk/glclassmanual



Roadside Assistance and Accident Management. Rest assured that should you ever need help, Mercedes-Benz Roadside Assistance is there for you. In the unlikely event of a technical breakdown³ you can rely on the Mercedes-Benz Roadside Assistance Team – anywhere in Europe. Mercedes-Benz will also assist you in the unfortunate event of an accident, from recovering your car and delivering it to your preferred Mercedes-Benz Retailer right through to managing your insurance claim in full, you will be looked after by the experts who built your Mercedes-Benz.⁴ Minor mishaps are also covered. Whether you lose your key, run out of fuel, or your vehicle is damaged due to vandalism, Mercedes-Benz ensures that you still reach your destination. Often the problem can be rectified on the spot, but if this is not possible, we will naturally ensure that your vehicle is taken to the nearest Mercedes-Benz Retailer to get you back on the road as quickly as possible.

¹As rated by Defaqto, a leading UK independent financial research company

²Mercedes-Benz Motor Insurance is underwritten by Aviva Insurance Limited. Calls are charged at local rate and may be recorded. We may decline to quote in some circumstances

Simply phone our Customer Assistance Centre on 00800 1 777 7777,⁵ where our specialists will organise assistance for you.

Service Care. To keep a tight grip on costs, Mercedes-Benz offers service plans to cover the costs of an annual service, for two, three and four years. Plans can be paid monthly with interest-free instalments or alternatively, if you pay upfront, should you sell your vehicle any remaining services will be transferred to the new owner. All routine maintenance and additional items are covered. To find out more, please contact your local Retailer or visit www.mercedes-benz.co.uk/servicecare

³Cover is initially valid for your vehicle for four years from the date of first registration. This can be extended from the fifth year, up to a maximum of 30 years, on completion of each scheduled maintenance service, providing that this service is carried out by a Mercedes-Benz

Mercedes-Benz World at Brooklands. Discover Mercedes-Benz racing heritage, from its connections to the famous Brooklands circuit through to present-day Formula 1™ brought to life in the most sensational way at Mercedes-Benz World in Surrey. View, touch and sit in every car from the Mercedes-Benz range, and encounter automotive legends like the ‘Gullwing’ and many other classic icons, in the UK’s largest Mercedes-Benz showcase. Then set your pulse racing by booking one of our thrilling Driving Experiences. Relax and refuel in Cafe 1886, or for something more enjoy the delicious menu and elegant surroundings of the Gullwing Restaurant. For more information, visit www.mercedes-benzworld.co.uk

Retailer. Minor mishap cover is provided at the absolute discretion of Mercedes-Benz

⁴Management of claims for non-fault accidents only

⁵In non-affiliated European countries: +44 20 7975 7077



Dimensions

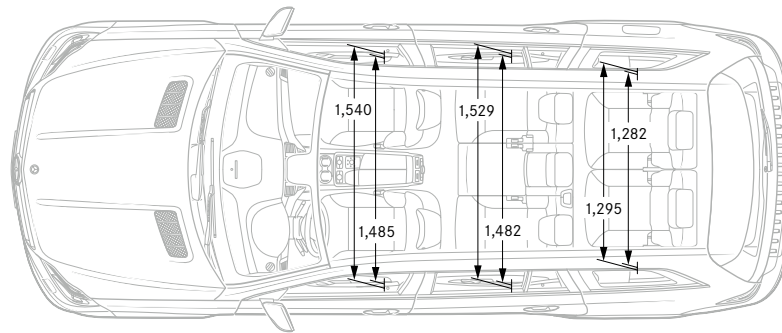
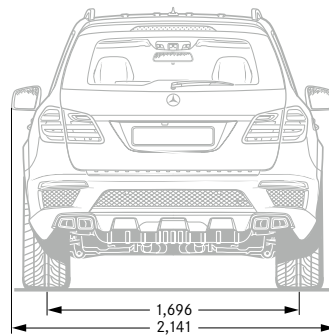
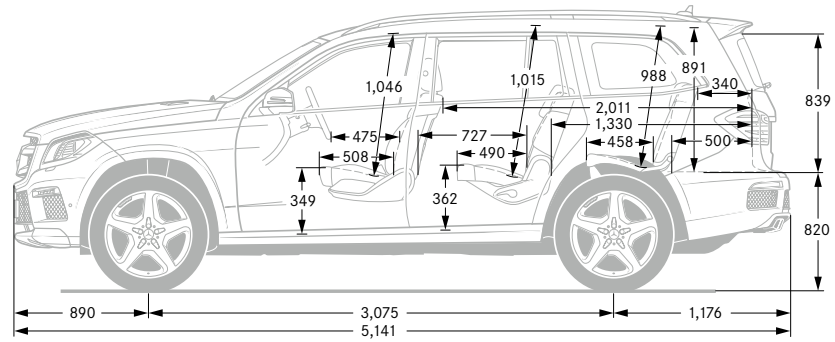
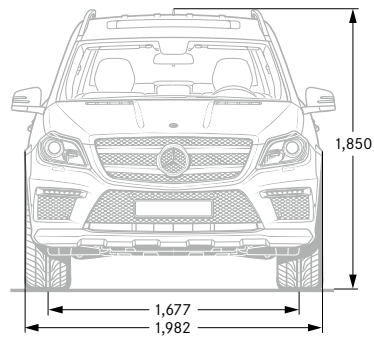

The luggage capacity is 680 litres, up to a maximum of 2,300 litres, and the payload 795 kg
 All measurements in millimetres. The dimensions shown are mean values and apply to standard-specification, unladen vehicles



Load compartment

Whatever your plans, the new GL-Class offers plenty of individual storage solutions. The load area of the 7-seater can be increased by simply folding the rear seats to suit your requirements. As a 2-seater, the GL-Class reaches its maximum loading capacity with a loading length of just

over 2 metres, a width of one metre (between the wheel housings) and a maximum load capacity of 2,300 litres when loaded to the roof. But that's not all. The largest object can measure $1,830 \times 900 \times 760$ millimetres or take up a volume of 1,252 litres, making it ideal for larger,

awkwardly-shaped objects. Normally these talents would be expected of a van, proving once more that the new GL-Class is much more than a luxurious SUV.

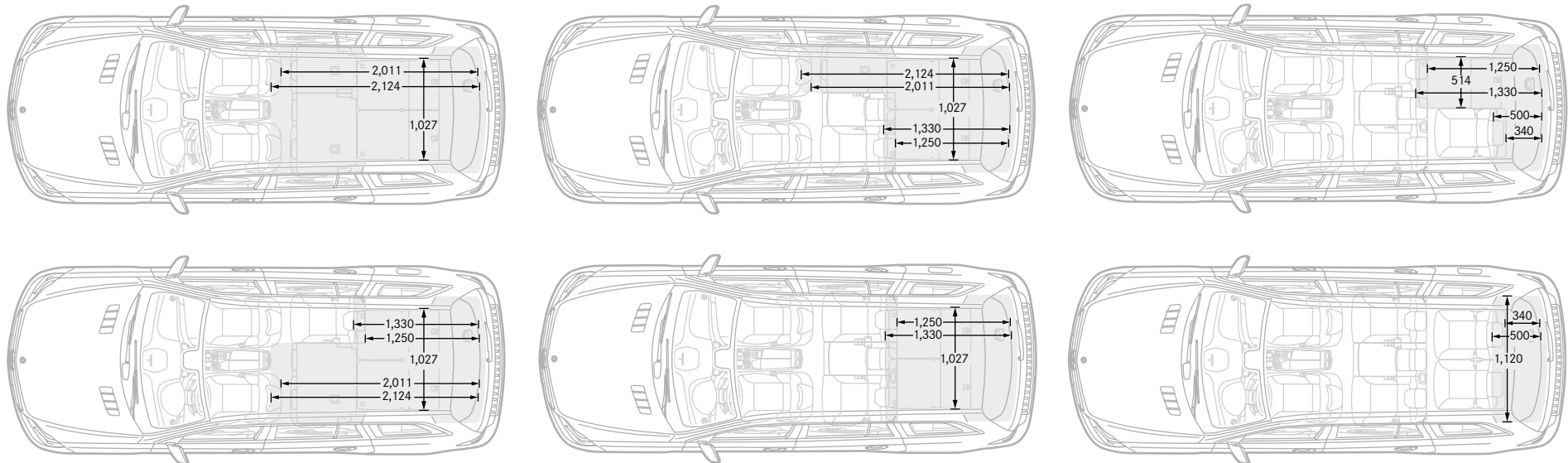

Load space length and width of the new GL-Class when used as a 2-, 3-, 4-, 5-, 6- and 7-seater (from top left to bottom right). All measurements in millimetres



Technical data

	Diesel engine	Petrol engine
	GL 350 BlueTEC AMG Sport	GL 63 AMG
Arrangement/cylinders/valves	V/6/24	V/8/32
Transmission	7G-Tronic Plus automatic	AMG Speedshift Plus 7G-Tronic automatic
Total displacement – cc	2,987	5,461
Rated output ¹ – hp (kW) at rpm	258 (190)/3,600	557 (410)/5,250–5,750
Rated torque ¹ – Nm at rpm	620/1,600–2,400	760/2,000–5,000
Acceleration 0–62 mph – sec	7.9	4.9
Top speed, approx. – mph	137	155 ²
Tyre size	295/40 R 21	295/40 R 21
Fuel consumption ³ – mpg		
Urban	31.7	17.9
Extra-urban	37.7	27.4
Combined	35.3	23.0
CO ₂ emissions, combined ³ – g/km	209	288
Emissions standard	EU6	EU5
Fuel tank capacity/reserve (approx.) – l	100/12,0	100/14,0
Boot capacity ⁴ – l	680–2,300	680–2,300
Turning circle – m	12.45	12.45
Kerb weight ⁵ /gross vehicle weight – kg	2,455/3,250	2,580/3,250
Towing capacity unbraked/braked – kg	750/3,500	750/3,250

¹ Figures in accordance with Directive 80/1269/EEC in the currently applicable version ² Electronically limited ³ The figures shown were obtained in accordance with the prescribed measuring process (Regulation [EC] 715/2007 in the currently applicable version).

The figures are not based on an individual model and do not constitute part of the product offer; they are provided solely for purposes of comparison between different vehicle models ⁴ Figures in accordance with Directive 70/156/EEC as amended by 2000/40/EC.

⁵ Figures in accordance with Directive 92/21/EC, version 95/48/EC (kerb weight with fuel tank 90% full, driver, 68 kg, and luggage, 7 kg) for standard-specification vehicles. Optional extras and accessories will generally increase this figure and reduce the payload capacity accordingly
For further technical data, please visit www.mercedes-benz.co.uk

Paint finishes

The paint system developed by Mercedes-Benz includes one of the best clearcoats on the automotive market and is a key factor behind the car's excellent value retention.

Non-metallic paint



149

Metallic paints

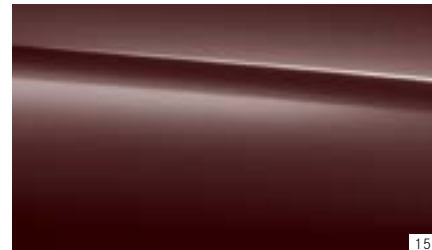

151

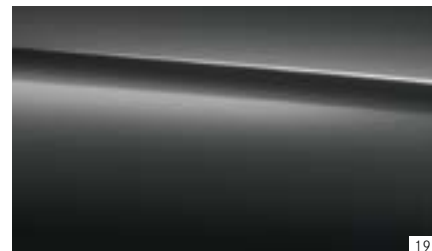

775

799¹

197



792



890



755



796

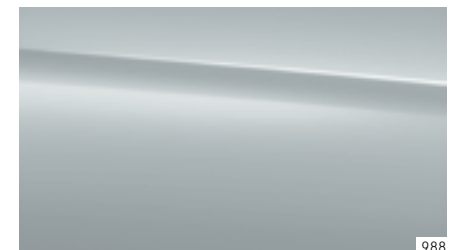

988

Non-metallic paint (no-cost option)

149 Polar White

Metallic paints (standard)

151 Cinnabar Red

197 Obsidian Black

755 Tenorite Grey

775 Iridium Silver

792 Palladium Silver

796 Citrine Brown

799 Diamond White¹

890 Cavansite Blue

988 Diamond Silver

¹Additional-cost option



Take-back of end-of-life vehicles. Coming full circle. At the end of its long life, you can return your GL-Class to us for environment-friendly disposal in accordance with the EC End-of-Life Vehicle Directive.¹ But that day lies a long way off.

¹Applies in accordance with national regulations to vehicles up to 3.5 t permissible gross weight. The GL-Class has met the statutory regulations governing the suitability of the vehicle's design for reuse and recycling for a number of years now. A network of vehicle take-back depots and dismantlers has been established which will process your vehicle in an environment-friendly manner. The ways in which both vehicles and parts can be recovered are subject to ongoing development and improvement. Consequently, the GL-Class will be able to comply with any future increases in the recycling quota within the stipulated time limits. Further information is available at www.mercedes-benz.co.uk or by calling 0808 156 6606.

Please note: this online version of the printed brochure may contain abridged copy or other content changes. The manufacturer reserves the right to make changes to the design, form, colour and specification during the delivery period, provided these changes, while taking into account the interests of the vendor, can be deemed reasonable with respect to the purchaser. Where the vendor or the manufacturer uses symbols or numbers to describe an order or the subject of an order, no rights may be derived solely from these. The illustrations may show accessories and items of optional equipment which are not part of standard specification. Colours may differ slightly from those shown. This brochure provides a general indication of the range of models, features, optional extras and/or colours available in various countries. Some of the models, features, optional extras and/or colours shown may not be available in your country or may only be available in a different specification. Additionally, some models, features, optional extras and/or colours may only be available in combination with others. For current and more specific information in relation to the range of models, features, optional extras and/or colours available in your country, and their pricing, you should contact your nearest authorised Mercedes-Benz Retailer. E&OE. www.mercedes-benz.co.uk

