



> View price list



> View offers



> SOUND WITH POWER



> Mercedes-Benz Magazine

SL-Class



Mercedes-Benz





> View price list



> View offers



> SOUND WITH POWER



> Mercedes-Benz Magazine

Athlete. Aesthete. The SL-Class

Tradition and innovation, exhilaration and safety, efficiency and performance: the SL is a consummate blend of contrasting qualities. The classic roadster lines hark back to its legendary predecessors, yet have a style that is unmistakably modern. The many intelligent assistants help you to steer clear of danger, and the adaptive suspension systems mean you can tailor the drive to your needs.

The cabin, too, leaves nothing to be desired, offering the kind of comfort that lets you just keep on driving, while the optional panoramic glass vario-roof with Magic Sky Control gives you views of the heavens even when closed, and switchable transparency to boot. What's more, the SL benefits from Frontbass, the first in-car speaker system to be integrated with the bodyshell. Pioneering technology that helps it to redefine roadster driving – again.





> View price list



> View offers



> SOUND WITH POWER



> Mercedes-Benz Magazine



Featured models at a glance:

**4 | Mercedes-Benz SL 500 AMG Sport
Palladium Silver**

AMG bodystyling, AMG 5-spoke alloy wheels, Black leather upholstery and brushed aluminium trim

**8 | Mercedes-Benz SL 350 AMG Sport
Hyacinth Red**

AMG bodystyling, AMG 5-spoke alloy wheels, Porcelain nappa leather upholstery and Black Ash wood trim

**12 | Mercedes-Benz SL 63 AMG
designo Magno Allanite Grey**

AMG 10-spoke alloy wheels, Black Exclusive Nappa leather upholstery and brushed aluminium trim

Equipment options at a glance:

16 | Engines and suspension

22 | Safety

24 | Comfort

36 | AMG

46 | Equipment

60 | Services

62 | Facts and finishes

Images may show accessories or items of optional equipment which are not part of standard specification





> View price list



> View offers



> SOUND WITH POWER



> Mercedes-Benz Magazine

Overview 4



The stuff of legends: exhilaration

More than 60 years ago, a roadster was born that would go on to be named 'sports car of the century'. It was, of course, the legendary 300 SL, the first in a long line of unforgettable Mercedes-Benz sports cars. The present incarnation is here to continue that tradition – and ensure the SL legend lives on.





> View price list



> View offers



> SOUND WITH POWER



> Mercedes-Benz Magazine

Your private jet for the road

5



Piloting the SL is a sensation that's hard to capture in words. Suffice to say the body is made almost entirely of aluminium, the suspension blends agility and comfort, and the engines are more powerful than ever. An SL is so much more than just the sum of these parts. It's a drive that has to be experienced to be believed. → Pages 18-21

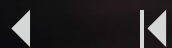



> View price list



> View offers



> SOUND WITH POWER



> Mercedes-Benz Magazine



Proves you have nothing left to prove

Surpassing oneself again and again is perhaps the greatest challenge of all. Yet the SL masters this effortlessly. The innovative BlueDIRECT technology is more powerful and efficient than ever, thanks to innovative and lightweight construction. Proof that reduced engine capacity can achieve greater performance and higher efficiency. Meaning the SL outdoes itself at petrol pumps too. → Page 17

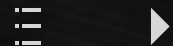



> View price list



> View offers



> SOUND WITH POWER



> Mercedes-Benz Magazine



Its loss is your gain

Sometimes doing without leads to greater rewards. That's why there are certain things you won't find on the SL: bass speakers in the doors, for instance. Instead, in a world first, it uses hollow structural members behind the footwell as resonance chambers. The result? A body that sounds every bit as good as it looks. → Pages 24-25





> View price list



> View offers



> SOUND WITH POWER



> Mercedes-Benz Magazine



A dream that never lets you drift off

The SL is an ever vigilant companion. Its many electronic assistants ensure you are equally alert, even recognising signs of tiredness, and its extensive network of safety systems make it one of the safest cars on the road. But then what else would you expect? It is, after all, the Mercedes-Benz among roadsters. → Pages 22–23





> View price list



> View offers



> SOUND WITH POWER



> Mercedes-Benz Magazine



Elation on demand

Roof down, accelerator floored – there's no finer way to release happiness hormones. In fact, euphoria is practically a permanent state in the SL. Its looks never fail to stir the soul; its performance is a joy that never wanes.

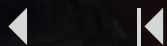



> View price list



> View offers



> SOUND WITH POWER



> Mercedes-Benz Magazine

Harnessed but never tamed

The acceleration leaves you breathless, but adaptive suspension and Direct Steering ensure you are the one in control. And should the horsepower suddenly need reining in, there are four-piston fixed-caliper front brakes that bring you rapidly to a standstill.

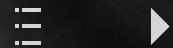



> View price list



> View offers



> SOUND WITH POWER



> Mercedes-Benz Magazine



Open the SL's panoramic glass vario-roof and sunshine isn't all you'll be basking in. Admiration is guaranteed too, with a cabin that's both sporty and supremely stylish. You can even leave it to soak up the rays without risk of the upholstery overheating, thanks to solar-reflective leather surfaces. An SL is not just for summer though: the panoramic glass vario-roof also gives you views of the heavens with the roof closed, while the optional Magic Sky Control goes from transparent to tinted at the touch of a button. → Pages 30-31

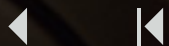



> View price list



> View offers



> SOUND WITH POWER



> Mercedes-Benz Magazine



Proof: the best can get better

What happens when you raise the bar? The SL 63 AMG. Unrivalled blend of power and efficiency meets the highest torque of any twin-turbocharged production V8. → Pages 36-39





> View price list



> View offers



> SOUND WITH POWER



> Mercedes-Benz Magazine

Your biturbo adrenalin boost awaits

Combine SL and AMG and you'd expect the results to be exhilarating. But the SL 63 AMG surpasses even the highest expectations. Superlative performance, breathtaking handling, Mercedes-Benz comfort: it's everything you could want in an SL – and then some.





> View price list



> View offers



> SOUND WITH POWER



> Mercedes-Benz Magazine



With a drive like this,
who wants to arrive?





The SL-Class in detail

Engines and suspension

- 16 | Mercedes-Benz Intelligent Drive and Mercedes-Benz Connect
- 17 | BlueEFFICIENCY
- 18 | Petrol engines
- 20 | Transmission
- 21 | Suspension

Safety

- 22 | Integrated safety concept

Comfort

- 24 | Multimedia systems
- 26 | Electronics assistants
- 28 | Open-top comfort
- 30 | Roof and space
- 32 | Air conditioning and lighting
- 34 | Seats

AMG

- 36 | SL 63 AMG
- 38 | SL 63 AMG technology
- 40 | SL 65 AMG
- 42 | SL 65 AMG technology
- 44 | AMG Performance Studio

Equipment

- 46 | Standard equipment
- 47 | Optional extras
- 48 | SL AMG Sport exterior
- 50 | SL AMG Sport interior
- 52 | Upholstery and trim
- 56 | Alloy wheels
- 58 | Retailer-fit accessories

Services

- 60 | Services

Facts and finishes

- 62 | Dimensions
- 63 | Technical data
- 65 | Paint finishes

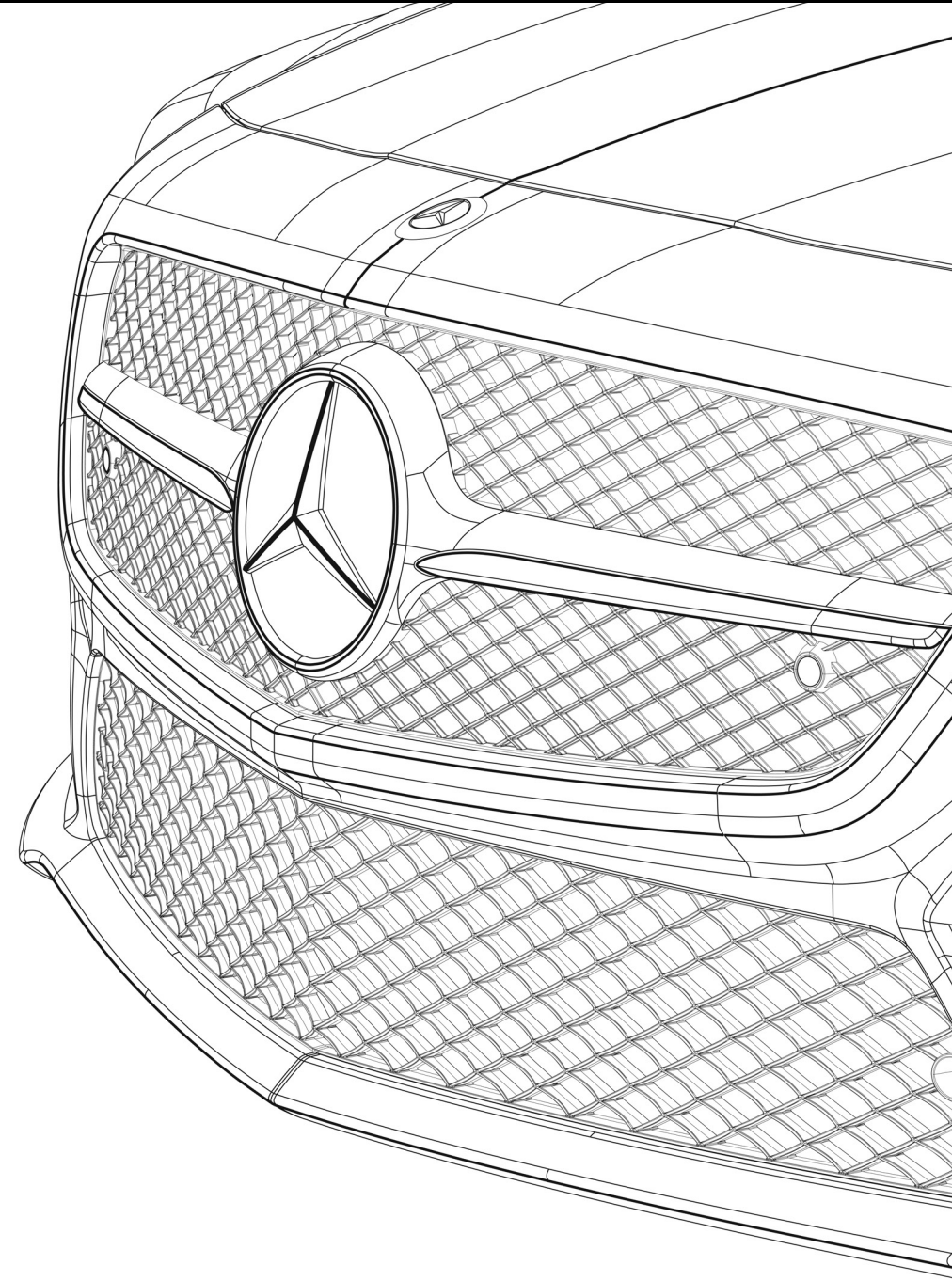



Connected with all the senses

With Mercedes-Benz Intelligent Drive and Mercedes-Benz Connect, we have taught our cars to think. It takes us one step closer to our vision of accident-free driving.

Our engineers live in the future, constantly aiming to turn innovative thinking into everyday solutions. This aspiration has resulted in many developments with a lasting impact on automotive engineering. In other words, our work ensures that a Mercedes-Benz is always ahead of its time.

Innovative technologies such as the Pre-Safe® anticipatory safety system and Distronic Plus radar-assisted cruise control first made it onto the road in a Mercedes-Benz, setting new standards in vehicle safety. It marked the first time active and passive systems were combined – for even better protection and ride comfort. Time and time again we have pioneered solutions to get closer to realising our vision of accident-free driving.

Mercedes-Benz Intelligent Drive takes things a step further by intelligently combining sensors with safety systems and electronic assistants. For us, it's a logical progression as the traffic situation has changed. There are more vehicles on the road, the driver's job is becoming more complex and distractions are increasing.

Radar-assisted Cruise Control with Steering Assist and Stop & Go Pilot marks another important step towards autonomous driving. Steering Assist provides lateral assistance to keep the car in lane. It works with a stereo camera capturing road markings and vehicles driving ahead at low speeds. The system brakes if necessary and accelerates to a preset speed when possible. As a result, your driving comfort is significantly enhanced, especially on long journeys or in slow-moving traffic jams.

Mercedes-Benz Connect. Serving as a smart interface between car and Internet, Mercedes-Benz Connect offers a whole range of services for your comfort, safety and information. It's an effortless, highly efficient way to keep the driver connected with the digital world when on the move. The system can be paired with COMAND Online, live traffic information, the Mercedes-Benz Emergency Call System and with many individual Mercedes-Benz apps. While your car remembers your preferences and adapts accordingly, it can even advise you to take specific actions and interact with your social networks. Mercedes-Benz Connect turns our vision of seamlessly connected mobility into reality. In the future, the way we drive will change dramatically, making it more comfortable, more efficient and safer as a result.

A Mercedes-Benz can monitor the road situation, alert you to possible dangers, and if necessary, act independently. Our cars are becoming increasingly intelligent, too. That is why a Mercedes-Benz takes you beyond a specific destination – it takes you straight to the future.





BlueEFFICIENCY – technology for more efficient driving

Mercedes-Benz is quicker at getting future technologies to where they matter most: on the road. With ever more efficient vehicles and a production process that wastes fewer and fewer resources. We call this comprehensive approach BlueEFFICIENCY. By way of example, BlueTEC technology for the diesel engine reduces nitrogen oxide

emissions by up to 90%. Our Hybrid models featuring an intelligent combination of internal combustion engine and electric drive can reduce fuel consumption significantly, while the SLS AMG Coupé Electric Drive takes electric mobility to a new level.



- 1 Lightweight construction with aluminium body and other weight-saving measures
- 2 Up to 29% lower fuel consumption thanks to BlueDIRECT engines (SL 350 and SL 500)
- 3 Aerodynamic optimisation (exterior mirrors, underbody guard)
- 4 Tyres designed for lower rolling resistance
- 5 Air-conditioning compressor only active on demand
- 6 Adjustable radiator shutter
- 7 ECO start/stop function
- 8 Current fuel consumption display
- 9 On-demand alternator
- 10 7G-Tronic Plus 7-speed automatic transmission
- 11 Energy-saving ancillary systems (on-demand fuel, oil and power steering pumps)
- 12 All engines meet EU5 emissions standards





Petrol engines

The SL is a sports car through and through, not least thanks to torquey and powerful engines that deliver performance on demand.

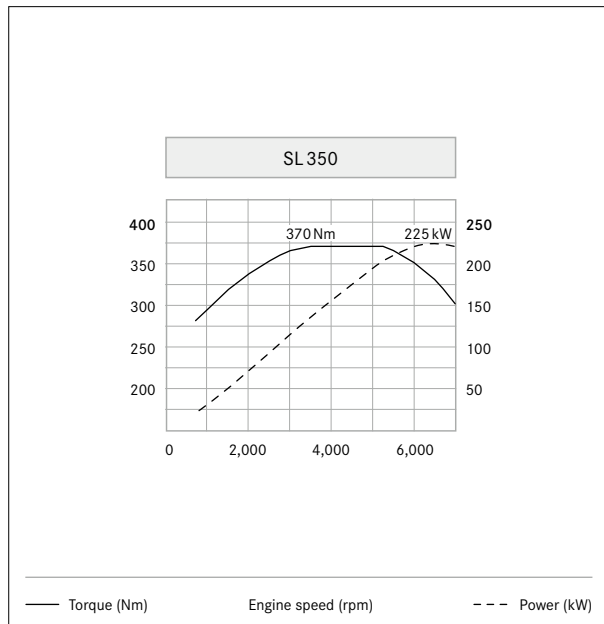

With an output of 306 hp (225 kW), the SL 350 delivers impressively dynamic performance

V6 petrol engine. The SL 350's innovative BlueDIRECT V6 engine features extensive use of lightweight materials and a range of advanced engine technologies. These include spray-guided direct petrol injection via piezo injectors, four valves per cylinder, and variable camshaft control for the intake and exhaust valves. The result is improved performance, combined with up to 29% reduction in fuel consumption and up to 22% reduction in CO₂ emissions. In addition, fuel consumption is further improved by the all-new air intake and exhaust system, on-demand ancillaries and intelligent alternator management. With an output of 306 hp (225 kW), the SL 350 offers powerful acceleration even at low engine speeds and excellent refinement across the rev range, while a special resonance intake manifold makes for a muscular engine sound.

V8 petrol engine. The SL 500's BlueDIRECT V8 offers a maximum output of 435 hp (320 kW) and some 700 Nm from 1,800 to 3,500 rpm. On the road, that means effortless performance whatever the speed or situation. Thanks to its lightweight construction, lower 4.7-litre displacement, direct petrol injection via ultra-precise piezo injectors and innovative BlueEFFICIENCY technologies, this engine succeeds in combining a significant increase in output and torque with a reduction in fuel consumption of up to 22%. The intercooled twin turbochargers, meanwhile, ensure instant pulling power is available at all times.





> View price list



> View offers



> SOUND WITH POWER



> Mercedes-Benz Magazine





Transmission

Innovative transmission technology ensures the power of the SL's free-revving engines is transferred effortlessly to the road.

7G-Tronic Plus (standard). The SL features our high-tech 7G-Tronic Plus 7-speed automatic transmission and comes with steering wheel shift paddles as standard. The seven forward gears allow for a wider spread between the lowest and highest gear, as well as more closely spaced ratios that make for almost imperceptible shifts. As a result, 7G-Tronic Plus improves acceleration, helps to optimise fuel efficiency and enables the ideal engine speed to be maintained at all times. It can also skip gears in downshifts for more rapid overtaking.

In the SL, the transmission benefits from a torque converter that makes for even faster responses, further reducing noise. Furthermore, fuel efficiency is significantly improved by ECO start/stop, which cuts the engine automatically at lights and in traffic jams.

The manual mode allows even more dynamic driving, whilst displaying the best gear choice for optimum fuel efficiency in the instrument cluster display. Following a predetermined interval, the transmission then returns to

the optimum automatic transmission mode. If preferred, the driver can choose the manual mode at all times.

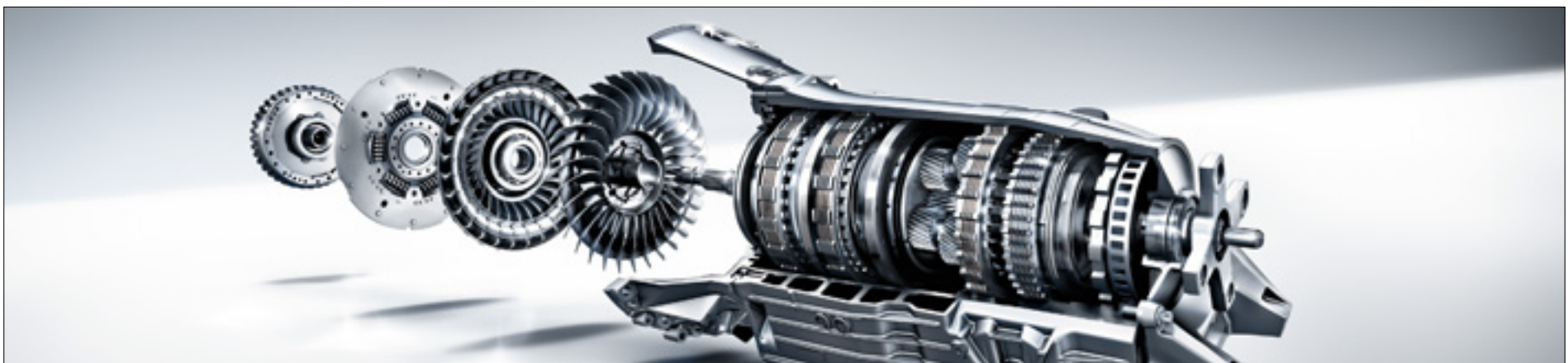

7G-Tronic Plus: the result of more than 50 years' experience in automatic transmission technology





Suspension

Thanks to intelligent electronics and individually selectable settings, the SL offers both exceptional cruising comfort and dynamic handling.

Active Body Control ABC (optional). Active Body Control (ABC) combines maximum ride comfort with enhanced dynamics, thanks to a combination of active suspension and passive damping. It helps to minimise pitching and diving under acceleration or sharp braking and also significantly reduces body roll when cornering. The driver can switch between 'Comfort' and 'Sport' settings at the touch of a button, with the chosen setting shown on the COMAND display.

Adaptive Damping System (standard). Via constant and seamless adjustments to each wheel's damping, this electronically controlled damping system adapts automatically to the situation and surface, giving you greater stability at all speeds. The system also features a 'Sport' mode that can be activated manually.

Direct Steering (standard). This variable-ratio steering system makes for more effortless manoeuvring with smaller inputs, as well as more agile cornering.

In addition, the electro-mechanical power assistance helps to reduce fuel consumption.

ESP® Dynamic Cornering Assist (standard). The system helps improve stability when cornering at high speeds. It intervenes by lightly applying the brakes on the rear wheel closest to the corner. The effect is an improved distribution of propelling forces to the rear wheels and further enhanced driving dynamics.



The standard suspension's Adaptive Damping System offers an ideal blend of agility and comfort





Integrated safety concept

Like all our passenger cars, the SL is built according to an integrated safety concept. It combines comprehensive occupant protection with intelligent systems that can help to prevent accidents from occurring.

As the inventor of the motor car, we feel a particular responsibility towards road safety. That's why we were the first manufacturer to develop an integrated safety concept that seamlessly combines a car's active and passive safety features, thus ensuring optimum all-round protection. This concept incorporates measures designed to maximise safety in every situation, by helping you to stay safe, alerting you to danger, and assisting you wherever possible. In addition, our unique Pre-Safe® anticipatory safety system recognises likely accident scenarios and takes steps that help to further enhance occupant protection. If a collision can't be avoided, intelligent passive safety systems help to provide protection where it's needed, while solutions that can minimise the consequences of an accident and facilitate emergency assistance are, of course, also included.

Our integrated safety concept spans four distinct phases: safer driving, anticipating danger, protecting occupants and post-crash safety. The following pages present some of the key features for each phase.

Safer driving: Attention Assist (standard). Particularly beneficial on long journeys, Attention Assist is an innovative system for detecting fatigue. Between speeds of approximately 50 and 110 mph, it assesses the driver's behaviour via an array of sensors and registers unexpected changes that may indicate tiredness or concentration lapses, such as involuntary movements of the steering wheel.

Safer driving: Intelligent Light System (standard). The Intelligent Light System offers a variety of modes and functions that optimise visibility for different types of driving, helping you to see the line of the road more clearly and spot potential hazards earlier. In country mode, the side of the road is illuminated more effectively, while motorway mode widens the beams to cover the entire carriageway. Fog mode improves visibility in bad weather, while cornering light and the Active Light System respond to steering inputs for better visibility in turns and bends. Also included is Adaptive High Beam Assist, a system that automatically adjusts the headlamps' range as required, dipping them whenever it spots the lights of an oncoming vehicle, then switching to

full beam as soon as the road is clear.

Safer driving: Magic Vision Control (standard). This adaptive windscreen wash system squirts the screenwash onto the windscreen via channels in the wiper blade. This improves visibility during washing, reduces the amount of fluid used and lessens the likelihood of spray entering the cabin when driving with the roof open. The Magic Vision Control system is also heated, along with the screenwash reservoir and pipes, helping to prevent them from icing over in cold weather.

Safer driving: Adaptive High Beam Assist (standard). Automatically maximises the headlamps' range then lowers them again as soon as the lights of an oncoming vehicle are detected. The system also takes into account the traffic conditions and adapts the lighting range accordingly.

Safer driving: Night View Assist Plus (optional). Using two LED-infrared headlamps and a thermal imaging camera, this further improved system captures pedestrians, animals or objects within a range of up to 520 metres ahead of the car. The Night View image is





automatically activated when the situation demands it and only switched off when the car has passed the hazardous area. The captured pedestrians or animals are highlighted in colour.

Safer driving: Driving Assistance Package (optional; standard on SL 65 AMG). For even greater levels of active safety, this option package adds DISTRONIC PLUS radar-assisted cruise control, Active Blind Spot Assist, Active Lane-Keeping Assist, Brake Assist (BAS) and Pre-Safe® Brake.

Anticipating danger: Pre-Safe® Brake and BAS Plus (part of optional Driving Assistance Package). If it detects the risk of a collision, Pre-Safe® Brake alerts the driver via visual and audible warnings. At the same time, BAS Plus assesses the brake force required in order to avoid an impact. If the driver applies the brakes but uses insufficient force, BAS Plus automatically raises the braking pressure to a level that exploits the remaining stopping distance to the full. Should the driver fail to

react to Pre-Safe® Brake's warning signals, the system applies the brakes automatically. If the driver still fails to respond, it then initiates autonomous emergency braking, enabling the speed and severity of any impact to be significantly reduced.

Anticipating danger: Pre-Safe® anticipatory safety system (standard). If it detects a probable accident scenario, Pre-Safe® can take anticipatory measures in order to protect the occupants, such as activating the seat belt tensioners, automatically closing the windows and moving the passenger seat to a safer position for an impact.

Protecting occupants: restraint systems (standard). The SL's 3-point seat belts, seat belt tensioners, belt force limiters and airbags work together to keep injuries to a minimum, activating as the type and severity of the accident requires. The dual-stage front airbags protect the head and upper body and also help to hold the body in place, while the standard headbags and sidebags

can reduce the risk of injury from side-on collisions. If the crash sensors detect an impact, the seat belts are instantly tensed, helping to ensure the occupants remain firmly in their seats, with the belt force limiter relaxing the belt as the situation allows in order to prevent undue force being applied to the rib cage.

Post-crash safety: Mercedes-Benz Emergency Call System (part of COMAND Online). Should the restraint systems' sensors detect an accident, the emergency call system can use a mobile phone to automatically contact the emergency services (if the phone is switched on and connected to the vehicle). In addition, it simultaneously sends GPS data and other vehicle information to the Mercedes-Benz emergency call centre, where an operator will attempt to make contact with you by phone.



Multimedia systems

The SL offers a range of first-class audio and navigation systems. Frontbass ensures exceptional acoustics, while the COMAND Online system combines audio and video entertainment with hard drive navigation.

Bang & Olufsen BeoSound AMG (optional on SL 63 AMG; standard on SL 65 AMG). With Frontbass, 12 high-performance speakers and a 900-watt output, this high-end surround sound system turns your SL into an open-topped concert hall. The bass speaker's resonant volume is integrated into the body shell, plus the combination of tweeters featuring acoustic lens technology results in the most brilliant sound stage - even with the hood down.

Harman Kardon® Logic 7® surround sound system (optional). The 600-watt Logic 7® surround sound system with Frontbass and Dolby Digital 5.1 makes every journey a listening experience to remember. Its 14 high-performance speakers and MOST amplifier with digital sound processing deliver three-dimensional sound, while speed-sensitive volume control ensures optimum enjoyment at all times.

COMAND Online system (standard). The system combines hard disk drive (HDD) navigation with a high-resolution 7-inch colour display for 3D map viewing. Multimedia functions include radio, speed-sensitive volume control, music register with 10 GB of storage for audio files, free European map data updates¹ and live traffic information,¹ which provides precise, up-to-date traffic data for improved route planning and more accurately estimated time of arrival. A USB connection, SD memory card slot, Bluetooth® interface for hands-free access and the Media Interface allow connection to external data storage media. The DVD drive can play video and audio DVDs as well as CDs and MP3 files. The online feature allows access to the Internet and Mercedes-Benz apps via an Internet-enabled mobile phone, including Facebook, Internet radio, parking space search, special destination searches via Google Street View or sending routes from Google™ maps to the vehicle, and hotel finder as well as news and weather reports. You can operate the system via the COMAND controller and the multi-function steering wheel, or simply use Linguatronic voice control.

¹Free of charge for the first three years



Aesthetic audio: acoustic lenses make for enhanced sound and an exclusive look





> View price list



> View offers



> SOUND WITH POWER



> Mercedes-Benz Magazine

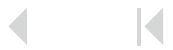
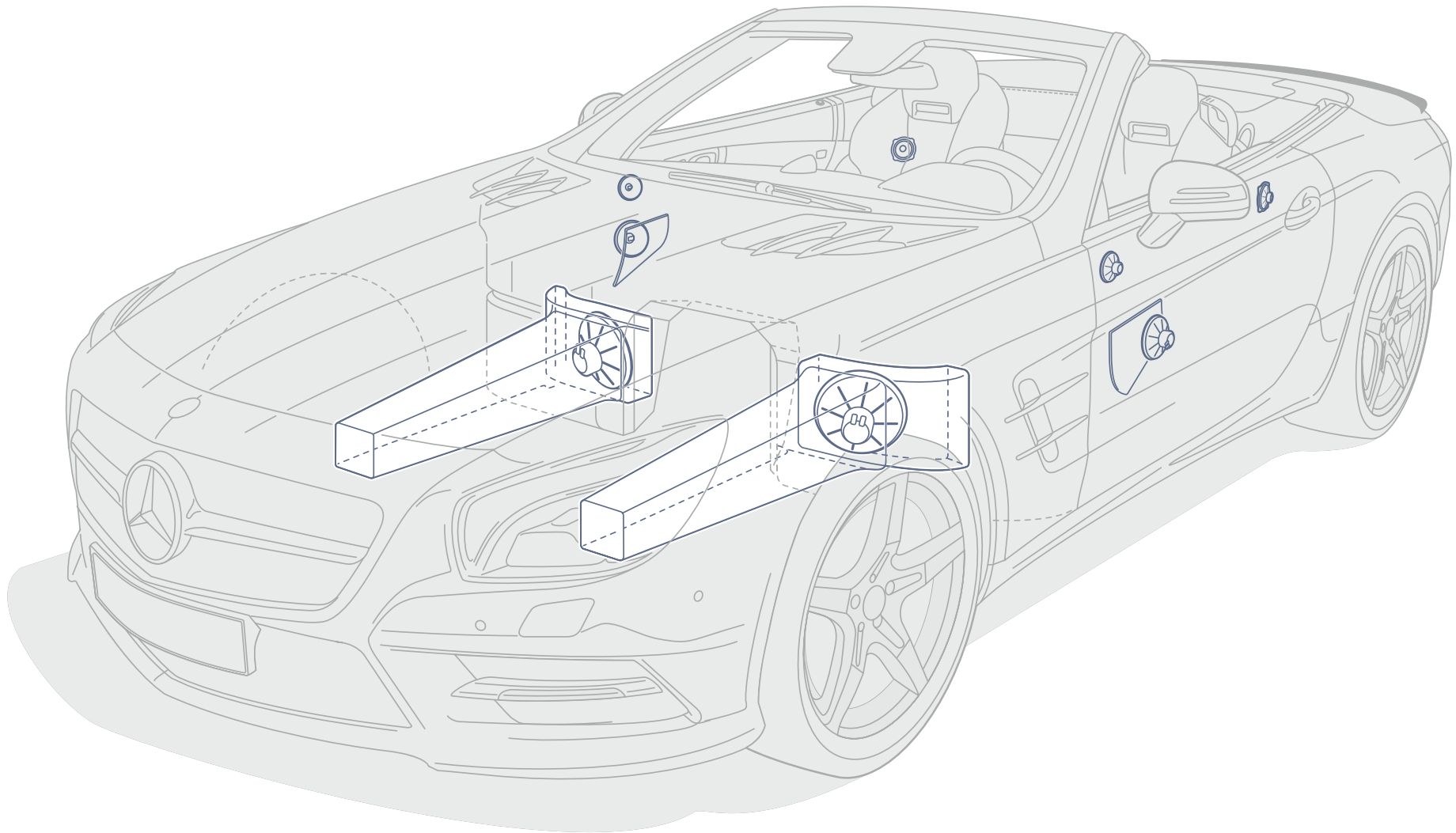



> View price list



> View offers



> SOUND WITH POWER



> Mercedes-Benz Magazine

Electronic assistants

The SL offers a range of helpful assistants that make for more effortless driving and manoeuvring, helping to ensure your journey is as relaxing as possible.





Speed Limit Assist (part of the standard COMAND Online system). Thanks to a windscreen-mounted camera that permanently scans the car's surroundings, Speed Limit Assist can recognise speed limits and display them in the instrument panel. Particularly useful in areas where the limit varies or when passing through roadworks, it helps to make sure the driver is aware of the legal limit for the current road or situation.



Speed Limit Assist shows you the current legal limit on the instrument panel and in COMAND Online's central display

Parktronic with Active Park Assist (standard). At low speeds, Active Park Assist looks for parking spaces automatically and, if it finds a suitable space, alerts the driver via a 'P' and an arrow in the instrument panel. If the driver then accepts the proposed space and engages reverse, the system steers you in automatically, leaving you to simply operate the accelerator, transmission and brakes as required. The manoeuvre takes a maximum of five moves and can be interrupted or corrected manually at any time. If Active Park Assist is not used, the



Active Park Assist identifies suitable parking spaces and can even steer you in automatically

Parktronic parking aid watches over the front and rear when manoeuvring at speeds of up to 10 mph and warns you should you get too close to another vehicle or object.



Open-top comfort

The SL is roadster driving at its most refined – in any season and almost any kind of weather.

Airscarf (optional; standard on SL 65 AMG). Developed in-house at Mercedes-Benz, Airscarf is a heating system that lets you extend the open-top season. Thanks to subtly integrated vents in the head restraints, it can send a stream of warming air towards the head and neck of each occupant, enabling you to keep the roof down even in cooler weather.

Electric wind deflector (optional). The electric wind deflector keeps the cabin almost entirely free of draughts when driving with the roof open. It comprises a textile mesh within a trapezoidal frame that can be raised electrically at the touch of a button located in the centre console.

Solar-reflective leather (standard in conjunction with leather, nappa leather or Exclusive Nappa leather upholstery; not available with *designo* leather). The SL is available with solar-reflective leather upholstery. In bright sunshine, its special coating helps the seat surfaces to stay cooler, ensuring optimum comfort even on the hottest of days.



The Airscarf neck-level heating system lets you enjoy open-top driving even in cooler weather



The electric wind deflector keeps draughts to a minimum in open-top driving





> View price list



> View offers



> SOUND WITH POWER



> Mercedes-Benz Magazine





Roof and space

The SL leads the way in roadster comfort. Its panoramic glass vario-roof provides all-weather protection and generous luggage space, while the Magic Sky Control version offers switchable transparency with the roof closed.

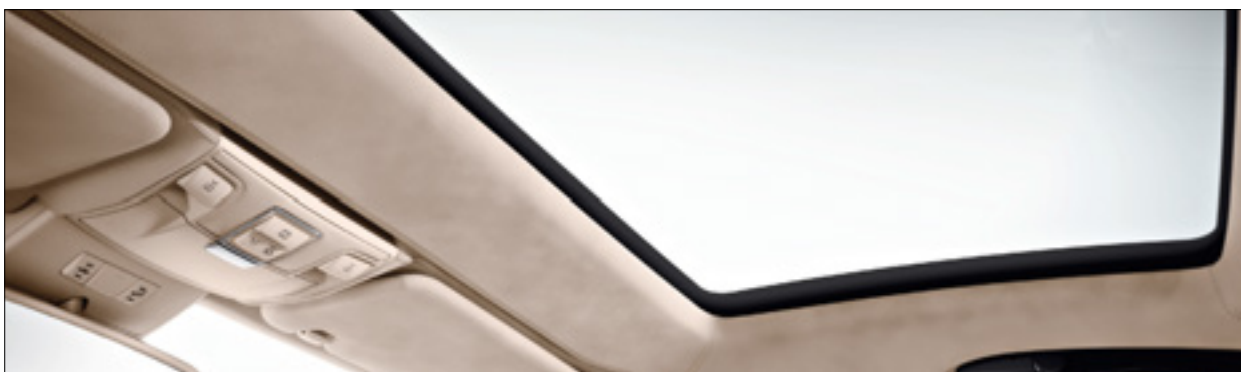

Panoramic glass vario-roof with Magic Sky Control (optional). Available for the panoramic vario-roof, Magic Sky Control can switch from transparent to tinted at the touch of a button, allowing you to choose between maximum light or effective protection from glare. With the roof closed, Magic Sky Control's tinted mode also makes for a significantly cooler cabin on hot days. Magic Sky Control is a Mercedes-Benz innovation.

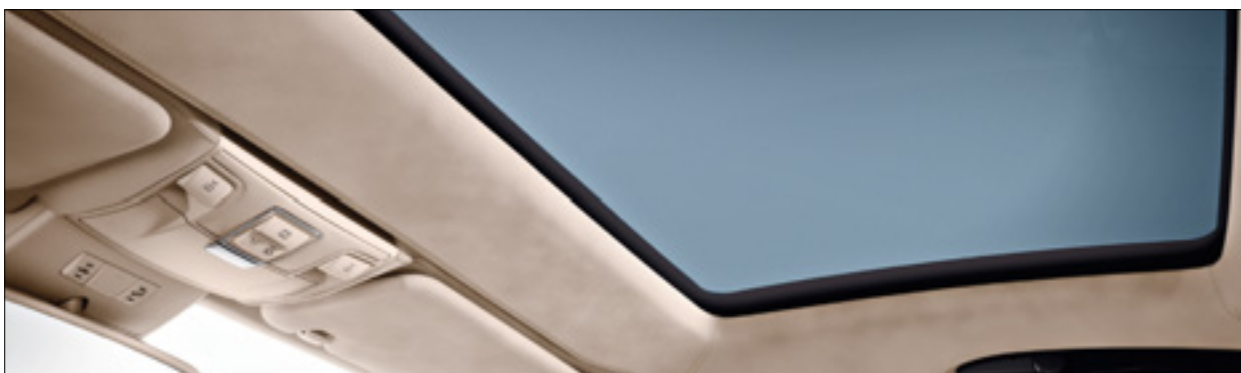

Roof lining in Dinamica microfibre (available for SL 63 AMG and SL 65 AMG only)





Panoramic glass vario-roof with blind (standard). The electro-hydraulic panoramic glass vario-roof makes the SL a genuine all-season roadster, transforming it from a two-seater coupé into an open-top roadster in less than 20 seconds. Its large tinted glass surface affords clear views of the sky above, while a manually operated blind offers shade in bright sunshine. The panoramic glass vario-roof folds neatly away into the boot, leaving up to 364 litres of luggage capacity, and can be raised

again just as quickly. It can also be opened and closed remotely via an infra-red enabled car key.

Easy-Pack function (standard). By allowing the folded roof to be lifted electrically, the convenient Easy-Pack function gives you easier access to your luggage when the roof is stowed. Pressing the button on the boot lid returns the roof to its original position and closes the boot lid.

Keyless-Go Comfort Package with hands-free boot access (optional; standard on SL 65 AMG). Keyless-Go allows you to open and start the car without needing to reach for the car key. As long as you have the Keyless-Go remote on you, you simply touch the door handle to unlock the car. Once settled into your seat, just press the start/stop button to bring the engine to life. The package also includes a hands-free boot access function: simply place your foot beneath the rear and the sensor-controlled boot lid will be released or closed automatically.



The SL's boot offers ample luggage space even with the roof open



The panoramic glass vario-roof offers clear views of the sky even when closed



Climate control and interior lighting

The right cabin climate makes for a relaxed, alert driver and a contented passenger. Which is why the SL lets each choose their own individual temperature settings.

Luxury automatic climate control (standard). The two-zone luxury automatic climate control system maintains separate preset temperatures for each side of the cabin, compensating automatically for external influences such as sunlight, air quality and humidity in the process. The system also includes a combined dust and activated

charcoal filter that captures particulates and improves air quality. By allowing driver and passenger to tailor the cabin climate to their needs, it ensures both enjoy optimum comfort and helps the driver to stay relaxed and alert at all times. There is even a choice of three individual climate settings: Diffuse, Medium and Focus.

Ambient interior lighting (optional; standard on SL 63 AMG and SL 65 AMG). The ambient interior lighting further enhances the cabin's sporty feel when driving at night. Comprising distinctive ambient lighting on the dashboard, in the doors and behind the seats, it is activated and deactivated when the headlamps are switched on or off and also comes on when the door is opened, ensuring a warm welcome every time you return to the car. There are three colour settings to choose from – Solar, Solar Orange and Solar Red – each of which can be dimmed to achieve the desired brightness.



The automatic climate control system helps you maintain a pleasant cabin temperature in all weathers





> View price list



> View offers



> SOUND WITH POWER



> Mercedes-Benz Magazine

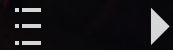



> View price list



> View offers



> SOUND WITH POWER



> Mercedes-Benz Magazine

Seats

The sports seats for the SL are designed for the very highest standards of comfort and safety.

The SL's electrically heated sports seats offer excellent ergonomics and come with high side bolsters that ensure optimum support and a firm hold even in fast cornering. The seats are heated independently of each other, with a choice of three settings, and their warmth can be felt even before the cabin begins to heat up. You can even have different temperature settings for seat cushion and backrest. The seats come with full electric adjustment including electro-pneumatic four-way lumbar adjustment and a memory function that enables you to store and recall the positions of the driver and passenger seat, the steering wheel and the exterior mirrors.

As well as supple, solar-reflective leather upholsteries that help you to stay cool in hot weather, the options include comfort-ventilated seats with perforated leather and fans

within the seats. The tiny perforations allow cooling air to pass through the seat surfaces, helping to prevent them from getting hot even under prolonged exposure to bright sunshine. Standard for the SL 63 AMG and SL 65 AMG are multi-contour seats that help to reduce the load on the spine and can be tailored to suit different body shapes. The air pressure in the adjustable chambers of the side bolsters in the backrests, can be adjusted according to the needs of each occupant, as can the curvature of the backrest in the lumbar and shoulder area. The dynamic multi-contour seats in the optional Active Multi-Contour Seat Package offer all this and more: they also constantly adapt to changes in the car's lateral acceleration, help to reduce the risk of injuries in an accident, and can even massage your back while you drive.



The standard electric seat adjustment with memory function





> View price list



> View offers



> SOUND WITH POWER



> Mercedes-Benz Magazine



Comfort 35

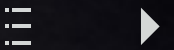



> View price list



> View offers



> SOUND WITH POWER



> Mercedes-Benz Magazine

SL 63 AMG

With its dramatic styling and race-honed technology, the SL 63 AMG is a roadster that's guaranteed to thrill. → www.mercedes-benz.co.uk/amg



The SL 63 AMG combines exceptional performance and remarkable efficiency





The SL 63 AMG says performance even at a standstill. Its muscular AMG bodystyling comprises side skirts, a front apron with side air vents and a rear apron with a body-colour diffuser-style insert, while AMG 5-twin-spoke alloy wheels further add to the dynamic look. The front apron's cross-bar, the bonnet and side fins, the two-bar AMG grille and the AMG-specific LED daytime running lights boast silver chrome trim and there are 'V8 BITURBO' badges on the front wings. At the rear, an AMG boot lid spoiler and an AMG sports exhaust system with two sets of chromed twin tailpipes complete the picture.

Climb inside and the racing feel is unmistakable, thanks to the combination of nappa leather-trimmed AMG Performance steering wheel with aluminium gear shift paddles, AMG Drive Unit with E-Select shift lever and AMG instrument panel with AMG start-up screen and Racetimer function for recording lap times. The nappa leather AMG sports seats feature model-specific stitching and are complemented by AMG carbon fibre interior trim and a black roof lining. The generous standard specification also includes Parktronic with Active Park Assist and a panoramic glass vario-roof with blind. Other eye-catching touches include an IWC-design analogue

clock, ambient interior lighting and white-backlit AMG door sill panels in brushed stainless steel.



AMG sports seats in nappa leather



Centre console with AMG Drive Unit



AMG sports exhaust system with two sets of twin chromed tailpipes





SL 63 AMG technology

AMG 5.5-litre biturbo V8, AMG Speedshift MCT 7-speed sports transmission and AMG sports suspension: the SL 63 AMG is designed to thrill.

AMG 5.5-litre biturbo V8. The SL 63 AMG is designed to maximise performance without sacrificing fuel efficiency. It delivers an exhilarating sound and truly breathtaking acceleration, thanks to an output of 537 hp (395 kW) plus 800 Nm torque (564 hp [415 kW] and 900 Nm with the optional AMG Performance Package). The improvement in performance and efficiency are the result of innovative technology such as direct petrol injection, twin turbochargers and ECO start/stop function.

For similarly impressive stopping power coupled with precise control, there are AMG high-performance composite brakes with internally ventilated, cross-drilled discs. The front discs are 390 × 36 mm; those at the rear measure 360 × 26 mm.

AMG Speedshift MCT 7-speed sports transmission. This high-tech system combines the involvement and directness of a manual transmission with the comfort

and convenience of an automatic. With its choice of 'Controlled Efficiency', 'Sport', 'Sport Plus' and 'Manual' modes plus Racestart function, it lets you tailor the gear shifts to your mood and needs.

AMG sports suspension. Based on the Active Body Control (ABC) system, the AMG sports suspension can be set to either 'Comfort' or 'Sport' mode, with the settings of the AMG sports parameter steering also reflecting your chosen mode. Together the AMG sports suspension and steering systems deliver exceptional accuracy, agility and feedback, ensuring cornering is always a thrill.



The AMG 5.5-litre biturbo V8 produces up to 564 hp (415 kW) and 900 Nm



The AMG Speedshift MCT 7-speed sports transmission offers smooth and rapid gear changes





> View price list



> View offers



> SOUND WITH POWER



> Mercedes-Benz Magazine

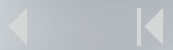
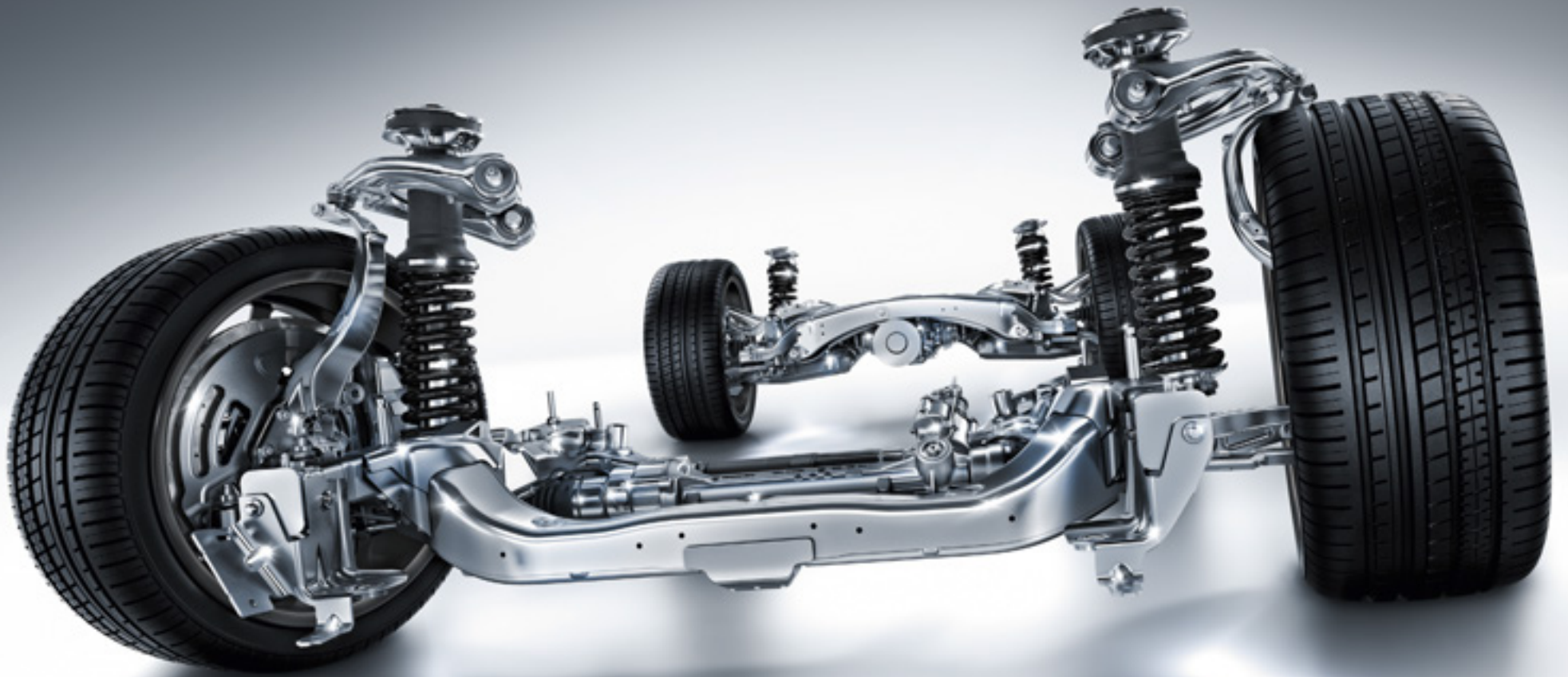



> View price list



> View offers



> SOUND WITH POWER



> Mercedes-Benz Magazine

SL 65 AMG

The SL 65 AMG is the epitome of luxury, exclusivity and power.



The SL 65 AMG combines exhilarating performance and exclusive luxury





In addition to the SL 63 AMG's muscular AMG bodystyling, the SL 65 AMG features differentiating details such as model-specific chromed twin tailpipes, 'V12 BITURBO' badges on the front wings and the front apron's high gloss chromed cross-bar. The two-bar AMG grille, bonnet and side fins are also finished in high gloss chrome, and there are 19" AMG 5-spoke alloy wheels as standard.

Inside, there's an unmistakable air of luxury, thanks to comfort-ventilated multi-contour seats, Exclusive Nappa leather upholstery with embossed 'AMG' backrest badges

and diamond-pattern stitching, and a Black *designo* leather roof lining. High sheen chrome AMG door sill panels with white backlighting guarantee an eye-catching welcome, while the Bang & Olufsen BeoSound AMG surround sound system provides a suitably high-end acoustic backdrop.

The SL 65 AMG's high-performance character, meanwhile, is further underlined by the nappa leather-trimmed AMG Performance steering wheel with aluminium shift paddles, the AMG Drive Unit and E-Select shift lever

with embossed 'AMG' badge, and the AMG carbon fibre interior trim.

The generous standard specification also includes telephone pre-wiring, Keyless-Go Comfort Package, Parktronic with Active Park Assist, Airscarf neck-level heating and a panoramic glass vario-roof with blind.



AMG sports seats in Exclusive Nappa leather with model-specific stitching



AMG instrument panel



AMG sports exhaust system with model-specific twin tailpipes





SL 65 AMG technology

Under the skin, the top-of-the-range SL roadster boasts an AMG 6-litre biturbo V12, AMG Speedshift Plus 7G-Tronic automatic transmission and AMG sports suspension.

AMG 6-litre biturbo V12. This high-performance V12 offers breathtaking performance allied to outstanding refinement. It delivers 630 hp (463 kW), gives you a mighty 1,000 Nm of torque all the way from 2,300 to 4,300 rpm and comes with ECO start/stop for enhanced fuel efficiency. Like the SL 63 AMG, the SL 65 AMG also features AMG high-performance composite brakes for impressive braking performance.

AMG Speedshift Plus 7G-Tronic automatic transmission. This four-mode transmission offers exceptionally dynamic gear shifts plus high levels of efficiency, while allowing you to tailor the shift characteristics to your needs via a rotary switch. It also offers automatic throttle-blipping during downshifts, which makes for a satisfyingly sporty sound and helps to reduce load transfer, especially when braking into bends.

AMG rear-axle limited slip differential. The SL 65 AMG is fitted with a tailor-made AMG rear-axle limited slip differential lock for optimum road holding. It helps reduce slip on the wheel closest to a corner, allowing a quicker acceleration out of bends. It also keeps the vehicle stable during short braking manoeuvres and at high speeds.

AMG sports suspension. Like the SL 63 AMG, the SL 65 AMG features an AMG sports suspension based on Active Body Control (ABC) as well as AMG sports parameter steering.

Electronic Stability Programme (ESP®). The SL 63 AMG and SL 65 AMG both benefit from a selectable ESP® system that gives you added control over the handling characteristics. A special 'Sport Handling' mode can be activated via the ESP® button. Additionally, optional ESP® Cornering Dynamics Assist ensures greater traction and safety thanks to a targeted distribution of the propelling forces to the wheels.



The SL 65 AMG is the first V12 Mercedes-Benz to feature AMG Speedshift Plus 7G-Tronic automatic transmission



AMG rear axle locking differential with 40% locking effect





> View price list



> View offers



> SOUND WITH POWER



> Mercedes-Benz Magazine

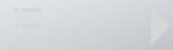



AMG Performance Studio

With options from the AMG Performance Studio, you can add extra individuality to your AMG SL.

Available for the SL 63 AMG, the AMG Performance Package features an engine upgrade that boosts the output by 27 hp (20 kW)¹ and increases maximum torque by 100 Nm as well as an increase in the electronically limited top speed and an improved 0-60 mph time.¹ It also adds a black nappa leather/Dinamica microfibre AMG Performance steering wheel, a carbon fibre rear spoiler and engine cover, red brake calipers and an AMG rear axle limited slip differential. Whilst the AMG Driver's

Package is equally included, it can also be ordered as an optional equipment for both SL 63 AMG and SL 65 AMG. It features an electronically limited top speed of 186 mph (and a Driver Training as part of the AMG Driving Academy). Other AMG Performance Studio options include striking 19"/20" AMG 10-spoke forged alloy wheels in either burnished Titanium Grey or matt black and AMG Performance suspension for the SL 63 AMG. The optional high-performance AMG ceramic composite

braking system, meanwhile, not only delivers enhanced stopping power and greater durability, it also improves agility and ride comfort by reducing unsprung mass. The AMG Performance Studio in Affalterbach can cater for many individual requirements and even create a unique tailor-made SL.

¹Output: 564 hp (415 kW); max. torque: 900 Nm; acceleration 0-62 mph: 4.2 s; top speed: 186 mph



SL 63 AMG with AMG Performance Package



AMG 10-spoke forged alloy wheels



High-performance AMG ceramic composite brakes





> View price list



> View offers



> SOUND WITH POWER



> Mercedes-Benz Magazine





> View price list



> View offers



> SOUND WITH POWER



> Mercedes-Benz Magazine

Standard equipment | Selection



Magic Vision Control, the world's first adaptive windscreen wash system



COMAND Online system with single-disc CD/DVD changer



Intelligent Light System



Adaptive Damping System (ADS) with 'Sport' and 'Comfort' modes



Direct Select gear selector in the centre console



Multi-function sports steering wheel with nappa leather trim and gear shift paddles





> View price list



> View offers



> SOUND WITH POWER



> Mercedes-Benz Magazine

Optional extras | Selection



Keyless-Go Comfort Package with hands-free boot access



Electric wind deflector



Airscarf neck-level heating system



Ambient lighting



Bang & Olufsen BeoSound AMG surround sound system. Available on SL 63 AMG and SL 65 AMG models only



Panoramic glass vario-roof with Magic Sky Control





SL AMG Sport exterior

The SL AMG Sport combines athletic looks with dynamic handling.

The AMG Sport features muscular AMG bodystyling comprising front and rear aprons and side skirts, as well as a boot lid spoiler in body colour. 19" AMG 5-spoke alloy wheels further enhance the striking looks. The 7G-Tronic Plus transmission comes with an 'S' mode featuring modified shift points for a more dynamic drive, and the

10-millimetre lower sports suspension offers firmer spring and damper settings (not available in conjunction with ABC). The uprated brakes, meanwhile, feature drilled discs front and rear with grey calipers featuring 'Mercedes-Benz' lettering. The AMG Sport comes in a choice of two engines: the SL 350 and the SL 500. The generous standard

specification also includes Parktronic with Active Park Assist and a panoramic glass vario-roof with blind.



The AMG Sport with its eye-catching rear apron and boot lid spoiler. Model shown with optional Hyacinth Red metallic paint¹



Burnished AMG 5-spoke alloy wheels

¹Please check with your Retailer for availability





> View price list



> View offers



> SOUND WITH POWER



> Mercedes-Benz Magazine





SL AMG Sport interior

The SL AMG Sport is as striking inside as out, thanks to a host of exclusive interior features.

The SL AMG Sport shines with a host of eye-catching details to the interior too. They include a chequered flag-design instrument cluster, a flat-bottomed sports steering wheel with silver gear shift paddles and perforated leather in the grip area, plus light brushed aluminium trim, and AMG floor mats. The sports seats feature Black perforated leather

with vertical fluting and have *designo* Platinum White Pearl piping on the seat side bolsters, head restraints, centre console and armrests.¹ (Nappa leather in either Bengal Red or Porcelain are available as options.)



Chequered flag instruments



Black leather sports seats with *designo* Platinum White Pearl piping

¹ Standard with Black leather (code 211). Not included with alternative upholstery choices (codes 807 and 815)





> View price list



> View offers



> SOUND WITH POWER



> Mercedes-Benz Magazine





Upholstery and trim



The black interior scheme features Black perforated leather with *designo* Platinum White Pearl piping as standard. For the SL 63 AMG there is perforated nappa leather as standard and perforated Exclusive Nappa leather as standard for the SL 65 AMG with Black top stitching and dark Alpaca Grey piping.

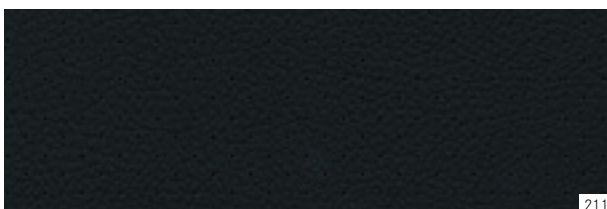

211



739



H73



H76

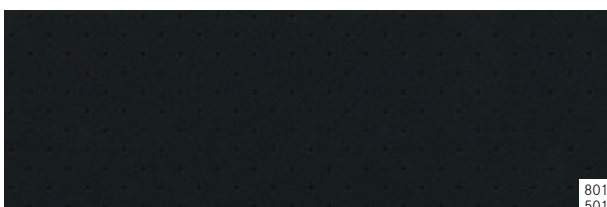

801
501



736



736



729

731

Black

- 211 Leather¹
- 801 Nappa leather^{2,3}
- 501 Exclusive Nappa leather^{4,5}

Trim

- 739 Light brushed aluminium^{1,6}
- H73 AMG carbon fibre^{2,5}
- H76 Dark brushed aluminium⁶
- 736 Black Ash wood, high gloss^{3,6}
- 729 Light Brown Poplar wood, satin finish⁶
- 731 Dark Brown Burr Walnut wood, high gloss⁶

¹Standard on SL 350 and SL 500 ²Standard on SL 63 AMG ³Optional on SL 350 and SL 500 ⁴Optional on SL 63 AMG ⁵Standard on SL 65 AMG ⁶No-cost option on the SL 63 AMG and SL 65 AMG only

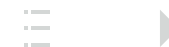



> View price list



> View offers



> SOUND WITH POWER



> Mercedes-Benz Magazine



The Ginger Beige/Espresso Brown interior scheme available for the SL 63 AMG and the SL 65 AMG only features perforated nappa leather or perforated Exclusive Nappa leather upholstery in Ginger Beige with Como Beige contrast stitching and Espresso Brown piping. For the SL 63 AMG there is nappa leather as standard, whereas Exclusive Nappa leather is standard for the SL 65 AMG and optional for the SL 63 AMG.

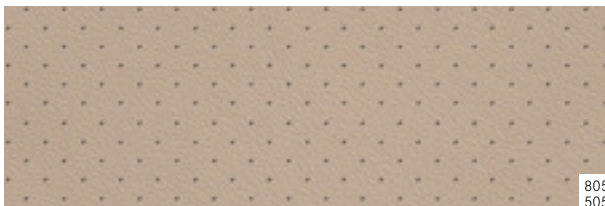

805
505

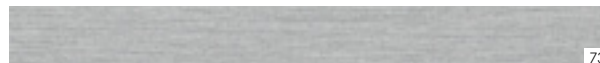

739

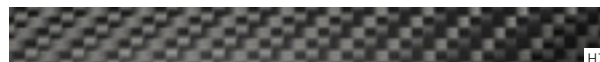

H73



H76



736



729



731

Ginger Beige/Espresso Brown

805 Nappa leather¹

505 Exclusive Nappa leather^{2,3}

Trim

739 Light brushed aluminium⁴

H73 AMG carbon fibre^{1,2}

H76 Dark brushed aluminium⁴

736 Black Ash wood, high gloss⁴

729 Light Brown Poplar wood, satin finish⁴

731 Dark Brown Burr Walnut wood, high gloss⁴

¹Standard on SL 63 AMG ²Standard on SL 65 AMG ³Optional on SL 63 AMG ⁴No-cost option on the SL 63 AMG and SL 65 AMG





> View price list



> View offers



> SOUND WITH POWER



> Mercedes-Benz Magazine



The Porcelain interior scheme features either nappa leather or Exclusive Nappa leather upholstery in Porcelain. The seats have Black piping with Porcelain top-stitching. For the SL 63 AMG there is perforated nappa leather as standard, and perforated Exclusive Nappa leather as standard for the SL 65 AMG.

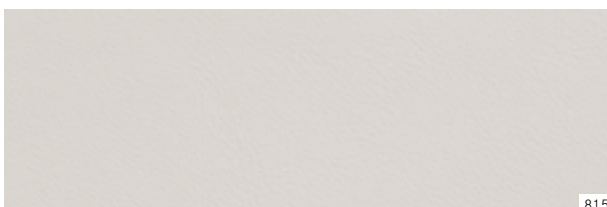

815

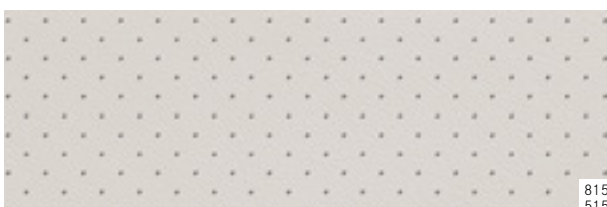

515



739

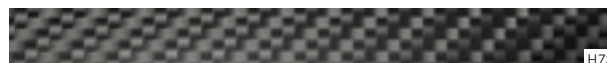

H73



H76



736



729



731

Porcelain

815¹ Nappa leather^{2,3}

515 Exclusive Nappa leather^{4,5}

Trim

739 Light brushed aluminium^{6,7}

H73 AMG carbon fibre^{2,4}

H76 Dark brushed aluminium⁷

736 Black Ash wood, high gloss^{3,7}

729 Light Brown Poplar wood, satin finish⁷

731 Dark Brown Burr Walnut wood, high gloss⁷

¹Non-perforated for SL 350 and SL 500 only ²Standard on SL 63 AMG ³Optional on SL 350 and SL 500 ⁴Standard on SL 65 AMG ⁵Optional on SL 63 AMG ⁶Standard on SL 350 and SL 500 ⁷No-cost option on the SL 63 AMG and SL 65 AMG only





> View price list



> View offers



> SOUND WITH POWER



> Mercedes-Benz Magazine



The Bengal Red interior scheme features nappa leather or Exclusive Nappa leather upholstery in Bengal Red with Black contrast stitching with Black piping. For the SL 63 AMG there is perforated nappa leather as standard, and perforated Exclusive Nappa leather as standard for the SL 65 AMG.

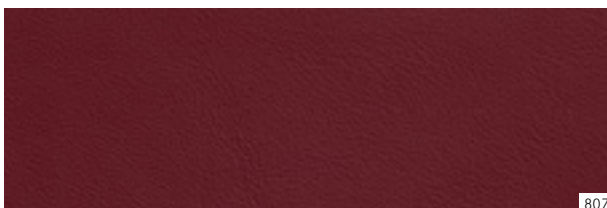

807

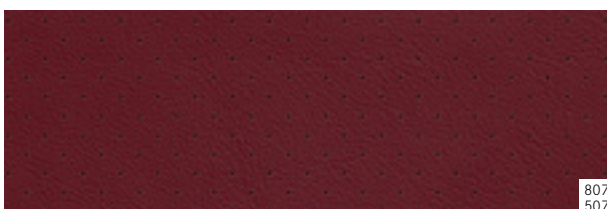

807
507



739



H73



H76



736



729



731

Bengal Red

807¹ Nappa leather^{2,3}

507 Exclusive Nappa leather^{4,5}

Trim

739 Light brushed aluminium^{6,7}

H73 AMG carbon fibre^{2,4}

H76 Dark brushed aluminium⁷

736 Black Ash wood, high gloss^{3,7}

729 Light Brown Poplar wood, satin finish⁷

731 Dark Brown Burr Walnut wood, high gloss⁷

¹Non-perforated for SL 350 and SL 500 only ²Standard on SL 63 AMG ³Optional on SL 350 and SL 500 ⁴Standard on SL 65 AMG ⁵Optional on SL 63 AMG ⁶Standard on SL 350 and SL 500 ⁷No-cost option on the SL 63 AMG and SL 65 AMG only





> View price list



> View offers



> SOUND WITH POWER



> Mercedes-Benz Magazine

Alloy wheels



19" AMG 5-spoke alloy wheels, burnished finish (standard on SL 350 and SL 500, code 770)





19" AMG 7-twin-spoke alloy wheels, painted in Titanium Grey with high sheen finish (optional on SL 350 and SL 500, code 785)



19" AMG 5-twin-spoke alloy wheels, painted in Titanium Grey (standard on SL 63 AMG, code 793)



19"/20" forged AMG 10-spoke alloy wheels, polished Titanium Grey finish (optional on AMG models, code 766)



19" AMG 7-twin-spoke alloy wheels, painted in black with high sheen finish (optional on SL 350 and SL 500, code 662)



19" AMG 5-spoke alloy wheels, burnished Titanium Grey finish (standard on SL 65 AMG, code 797)



19"/20" forged AMG 10-spoke alloy wheels, matt black finish with burnished rims (optional on AMG models, code 767)





> View price list



> View offers



> SOUND WITH POWER



> Mercedes-Benz Magazine

Retailer-fit accessories

Custom-designed for the SL, our Retailer-fit accessories are the perfect way to make your roadster sportier and even more practical.

→ www.mercedes-benz.co.uk/accessories



Eye-catching Retailer-fit 18" 5-spoke alloy wheels





Give your SL a truly individual look – with styling accessories such as Retailer-fit alloy wheels – or enhance its comfort and convenience with practical extras such as the iPhone® console. In conjunction with the telephone pre-wiring option it automatically connects your phone to the car’s hands-free facility, enabling you to operate your iPhone® via the car’s controls, while offering optimum reception, charging the battery and giving you access to files stored on the phone. Consoles are also available for a range of other popular handsets.

For the whole in-car communications experience, there’s the Mercedes-Benz telephone module with Bluetooth® (SAP) and 3G capability. It connects directly to the car’s external aerial, providing a fast, stable and secure Internet connection for the COMAND Online system. It also enables you to make calls, use Mercedes-Benz apps via COMAND Online and have your text messages read out to you. The telephone works in conjunction with the optional telephone pre-wiring concealed within the centre armrest.

The practical shallow boot tub is precision-tailored to the load area of the SL. It is easy to clean, has a studded surface to prevent loads from sliding around and is made of food-safe material.

All our Retailer-fit accessories offer the very highest standards of quality and safety. For more details, please see the relevant brochure or speak to your local Mercedes-Benz Retailer.



iPhone® console



Food-safe shallow boot tub



Services

Test drive. You've seen the pictures, you've read the facts. Now all that's missing is to experience your dream Mercedes in the flesh. Which is why we invite you to take it for a spin. See it with your own eyes. Rev up the engine, and feel how your chosen Mercedes hugs the road. Relax in style or play with a whole host of exciting onboard technology. Contact your Mercedes-Benz Retailer for a test drive, or simply go online and visit www.mercedes-benz.co.uk/testdrive. We can't wait to see you in the driving seat.

Mercedes-Benz Finance. At Mercedes-Benz Finance, our single-minded aim is to provide optimum financial solutions for all those who share the Mercedes-Benz philosophy of absolute commitment to quality. Whether you are a private customer or a business user, our finance and leasing packages can be tailored to meet your individual needs. For further information on Mercedes-Benz Finance, please contact your local Mercedes-Benz Retailer.



Mercedes-Benz Insurance offers a fully comprehensive 5-star-rated¹ Motor Insurance policy specifically designed to provide the cover you would expect from Mercedes-Benz. For a quotation, please call 0845 600 2180²

Interactive Owner's Manual. The website also offers an interactive tour, enabling you to take a closer look at your desired model. This simulation is the ideal way to acquaint yourself with your dream car. You can view key functions in detail, gain an insight into the car's inner workings or look at the benefits of each model. For further details, visit www.mercedes-benz.co.uk/slclassmanual



Roadside Assistance and Accident Management. Rest assured that should you ever need help, Mercedes-Benz Roadside Assistance is there for you. In the unlikely event of a technical breakdown³ you can rely on the Mercedes-Benz Roadside Assistance Team – anywhere in Europe. Mercedes-Benz will also assist you in the unfortunate event of an accident, from recovering your car and delivering it to your preferred Mercedes-Benz Retailer right through to managing your insurance claim in full, you will be looked after by the experts who built your Mercedes-Benz.⁴ Minor mishaps are also covered. Whether you lose your key, run out of fuel, or your vehicle is damaged due to vandalism, Mercedes-Benz ensures that you still reach your destination. Often the problem can be rectified on the spot, but if this is not possible, we will naturally ensure that your vehicle is taken to the nearest Mercedes-Benz Retailer to get you back on the road as quickly as possible.

¹As rated by Defaqto, a leading UK independent financial research company
²Mercedes-Benz Motor Insurance is underwritten by Aviva Insurance Limited. For joint protection, calls may be recorded and/or monitored. All calls are charged at local rate. We may decline to quote in some circumstances

Simply phone our Customer Assistance Centre on 00800 1 777 7777,⁵ where our specialists will organise assistance for you.

Service Care. To keep a tight grip on costs, Mercedes-Benz offers service plans to cover the costs of an annual service, for two, three and four years. Plans can be paid monthly with interest-free instalments or alternatively, if you pay upfront, should you sell your vehicle any remaining services will be transferred to the new owner. All routine maintenance and additional items are covered. To find out more, please contact your local Retailer or visit www.mercedes-benz.co.uk/servicecare

³Cover is initially valid for your vehicle for four years from the date of first registration. This can be extended from the fifth year, up to a maximum of 30 years, on completion of each scheduled maintenance service, providing that this service is carried out by a Mercedes-Benz Retailer. Minor mishap cover is provided at the absolute discretion of Mercedes-Benz

Mercedes-Benz World at Brooklands. Discover Mercedes-Benz racing heritage, from its connections to the famous Brooklands circuit through to present-day Formula 1™ brought to life in the most sensational way at Mercedes-Benz World in Surrey. View, touch and sit in every car from the Mercedes-Benz range, and encounter automotive legends like the ‘Gullwing’ and many other classic icons, in the UK’s largest Mercedes-Benz showcase. Then set your pulse racing by booking one of our thrilling AMG or 4×4 Driving Experiences. Relax and refuel in Café 1886, or enjoy the delicious menu and elegant surroundings of the Gullwing Bistro. For more information, visit www.mercedes-benzworld.co.uk

⁴Management of claims for non-fault accidents only
⁵In non-affiliated European countries: +44 20 7975 7077





Dimensions

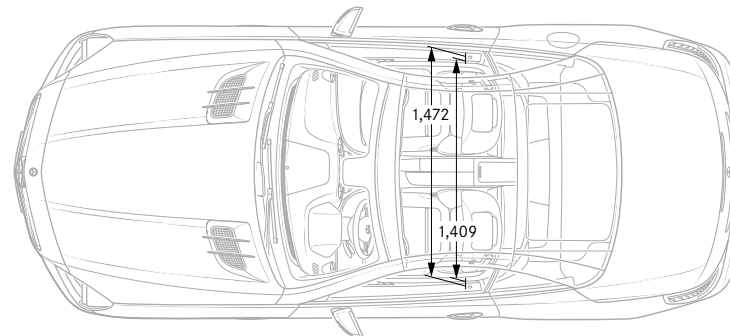
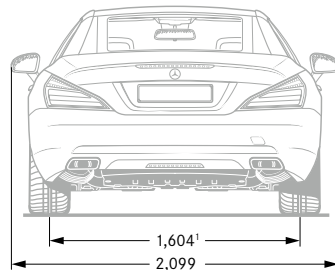
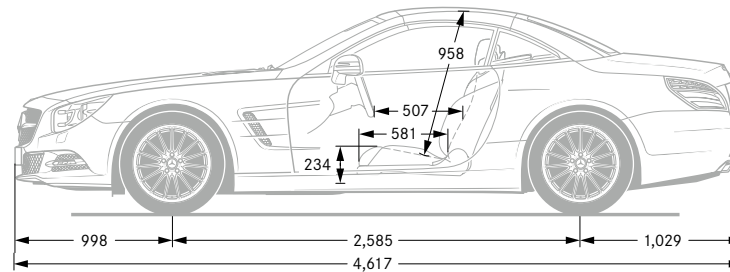
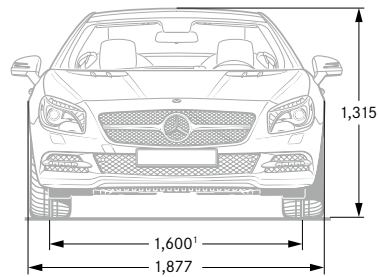

All measurements in millimetres. The dimensions shown are mean values and apply to standard-specification, unladen vehicles
¹With two occupants of 68 kg each





Technical data

	Petrol engines	
	SL 350	SL 500
Arrangement/cylinders/valves	V/6/24	V/8/32
Total displacement – cc	3,498	4,663
Rated output ¹ – hp (kW) at rpm	306 (255)/6,500	435 (320)/5,250
Rated torque ¹ – Nm at rpm	370/3,500–5,250	700/1,800–3,500
Acceleration 0–62 mph – sec	5.9	4.6
Top speed, approx. – mph	155 ³	155 ³
Fuel consumption ⁴ – mpg		
Urban	29.7	22.2
Extra-urban	47.9	40.4
Combined	39.2	31.0
CO ₂ emissions, combined ⁴ – g/km	169	212
EU emissions standard	EU5	EU5
Fuel tank capacity/of which reserve – l	65/8.0	65/8.0
Boot capacity – l		
with roof closed	504	504
with roof open	364	364
Turning circle – m	11.04	11.04
Kerb weight ⁵ – kg	1,685	1,785
Perm. GVW – kg	2,065	2,165

¹Figures in accordance with Directive 80/1269/EEC in the currently applicable version ²Figures in square brackets relate to AMG Performance Package ³Electronically limited

⁴The figures shown were obtained in accordance with the prescribed measuring process (Regulation [EC] 715/2007 in the currently applicable version). The figures are not based on an individual model and do not constitute part of the product offer; they are provided solely for purposes of comparison between different vehicle models

⁵Figures according to Directive 92/21/EC, version 95/48/EC (kerb weight with fuel tank 90% full, driver, 68 kg, and luggage, 7 kg) for standard-specification vehicles. Optional extras and accessories will generally increase this figure and reduce the payload capacity accordingly

⁶In conjunction with AMG Driver's Package

For further technical data, please visit www.mercedes-benz.co.uk





	Petrol engines	
	SL 63 AMG	SL 65 AMG
Arrangement/cylinders/valves	V/8/32	V/12/36
Total displacement – cc	5,461	5,980
Rated output ¹ – hp (kW) at rpm	537 (395)/5,500 [564 (415)/5,500 ²]	630 (463)/4,800
Rated torque ¹ – Nm at rpm	800/2,000–4,500 [900/2,250–3,750 ²]	1,000/2,300–4,300
Acceleration 0–62 mph – sec	4.3 [4.2 ²]	4.0
Top speed, approx. – mph	155 ³ [186 ^{2,4}]	155 ³ (186 ⁴)
Fuel consumption ² – mpg		
Urban	20.3	16.6
Extra-urban	37.2	33.6
Combined	28.5	24.4
CO ₂ emissions, combined ⁴ – g/km	231–231	270–270
EU emissions standard	EU5	EU5
Fuel tank capacity/of which reserve – l	75/14	75/14
Boot capacity – l		
with roof closed	504	504
with roof open	364	364
Turning circle – m	11.1	11.1
Kerb weight ⁵ – kg	1,845	1,950
Perm. GVW – kg	2,180	2,210

¹Figures in accordance with Directive 80/1269/EEC in the currently applicable version ²Figures in square brackets relate to AMG Performance Package ³Electronically limited

⁴The figures shown were obtained in accordance with the prescribed measuring process (Regulation [EC] 715/2007 in the currently applicable version). The figures are not based on an individual model and do not constitute part of the product offer; they are provided solely for purposes of comparison between different vehicle models

⁵Figures according to Directive 92/21/EC, version 95/48/EC (kerb weight with fuel tank 90% full, driver, 68 kg, and luggage, 7 kg) for standard-specification vehicles. Optional extras and accessories will generally increase this figure and reduce the payload capacity accordingly

⁶In conjunction with AMG Driver's Package

For further technical data, please visit www.mercedes-benz.co.uk





Paint finishes

The highly durable nature of the Mercedes-Benz paint system makes it one of the best clear coats available in the automotive industry. A highly dense molecular structure provides the key to the extremely resilient paint, regardless whether it's non-metallic or metallic, giving the surface a longer lasting, more intense shine.

Non-metallic paints (no-cost option)



149

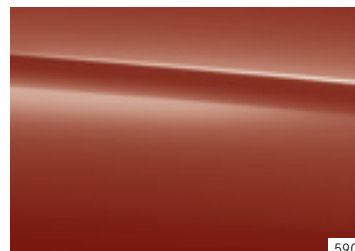

590

Non-metallic paints (no-cost option)

- 149 Polar White
- 590 Fire Opal

Metallic paints (standard)

- 183 Magnetite Black²
- 197 Obsidian Black
- 281 Cerussite Grey (matt finish)^{2,3}
- 526 Dolomite Brown²
- 755 Tenorite Grey²
- 775 Iridium Silver
- 792 Palladium Silver
- 799 Diamond White³
- 890 Cavansite Blue
- 996 Hyacinth Red^{3,4}

Metallic paints (standard)

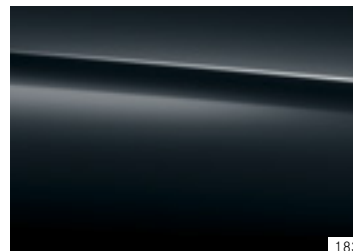

183²

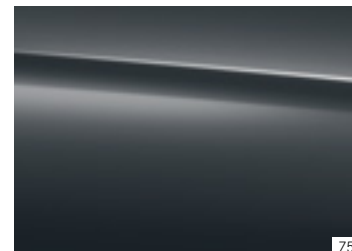

755²

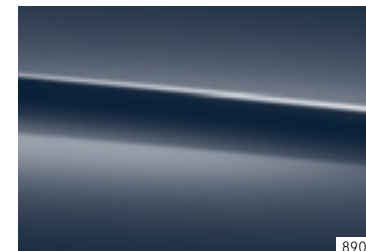

890

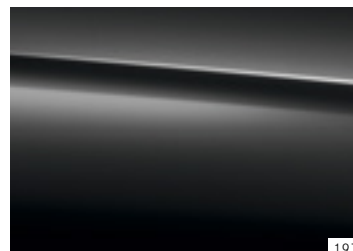

197

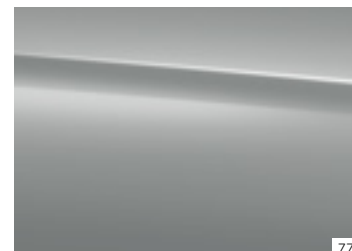

775

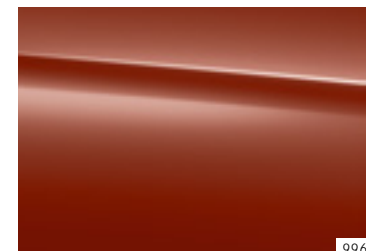

996^{3,4}

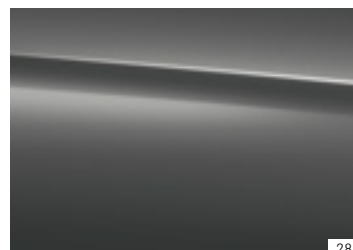

281^{2,3}

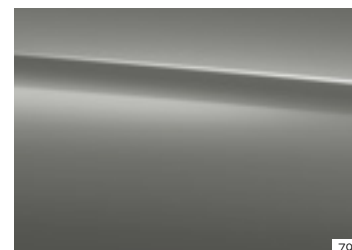

792

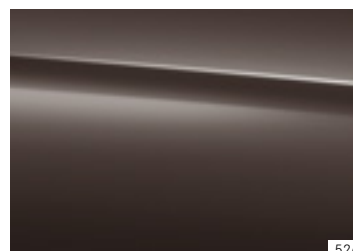

526²



799³

Other finishes available from the *designo* options range
²Available for SL 63 AMG and SL 65 AMG only
³Additional cost option
⁴Please check with your Retailer regarding availability





> View price list



> View offers



> SOUND WITH POWER



> Mercedes-Benz Magazine

Take-back of end-of-life vehicles. Coming full circle. At the end of its long life, you can return your SL-Class to us for environment-friendly disposal in accordance with the EC End-of-Life Vehicle Directive.¹ But that day lies a long way off.

¹Applies in accordance with national regulations to vehicles up to 3.5 t permissible gross weight. The SL-Class has met the statutory regulations governing the suitability of the vehicle's design for reuse and recycling for a number of years now. A network of vehicle take-back depots and dismantlers has been established which will process your vehicle in an environment-friendly manner. The ways in which both vehicles and parts can be recovered are subject to ongoing development and improvement. Consequently, the SL-Class will be able to comply with any future increases in the recycling quota within the stipulated time limits. Further information is available at www.mercedes-benz.co.uk or by calling 0808 156 6606.

Please note: this online version of the printed brochure may contain abridged copy or other content changes. The manufacturer reserves the right to make changes to the design, form, colour and specification during the delivery period, provided these changes, while taking into account the interests of the vendor, can be deemed reasonable with respect to the purchaser. Where the vendor or the manufacturer uses symbols or numbers to describe an order or the subject of an order, no rights may be derived solely from these. The illustrations may show accessories and items of optional equipment which are not part of standard specification. Colours may differ slightly from those shown. This brochure provides a general indication of the range of models, features, optional extras and/or colours available in various countries. Some of the models, features, optional extras and/or colours shown may not be available in your country or may only be available in a different specification. Additionally, some models, features, optional extras and/or colours may only be available in combination with others. For current and more specific information in relation to the range of models, features, optional extras and/or colours available in your country, and their pricing, you should contact your nearest authorised Mercedes-Benz Retailer. E&OE. www.mercedes-benz.co.uk

