



# The Atego. The Antos.

Distribution. 6.5-44 tonnes gcw.



Mercedes-Benz  
Trucks you can trust

# RoadStars: Come aboard – it's worth it.

**RoadStars.** RoadStars is the new, interactive communications platform from Mercedes-Benz for drivers, business owners and truck enthusiasts. You too can play an active part in the huge RoadStars community! Registered users are kept up to date with the latest information on a regular basis. You also have the opportunity to get more involved, for example by commenting, uploading pictures, chatting or sharing content.

As a member you can join in exclusive events, offers and experiences at Mercedes-Benz Trucks. Whether you're on a smartphone, tablet, laptop or desktop computer, RoadStars is there for you anytime, anywhere – all you need is an internet connection. Join in now and become a genuine RoadStar:  
[www.roadstars.mercedes-benz.com](http://www.roadstars.mercedes-benz.com)

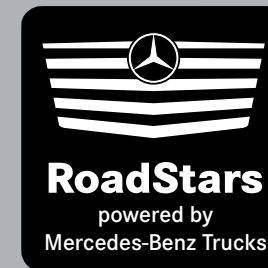

# Contents.

<b>Mercedes-Benz distribution transportation</b>	<b>4–5</b>	<b>Technical data Antos</b>	<b>42–47</b>
		Cab variants	42–43
		Tank variants	44
<b>The Atego 6.5–16 t</b>	<b>6–19</b>	Engine performance data frame, overhangs, end cross members	45
Cab, equipment	10–15	Model overview	46–47
Engines, transmissions, gearshift	16–17		
Driving comfort, body-mounting ability	18–19	<b>Content common to both model series</b>	<b>48–71</b>
<b>Technical data Atego</b>	<b>20–23</b>	<b>Efficiency in distribution transport operations</b>	<b>48–67</b>
Cab variants	20–21	Investment	50–55
Model overview	22–23	Consumption	56–61
		Service	62–65
<b>The Antos 18–44 t</b>	<b>24–41</b>	Residual value	66–67
Cab, equipment	28–33		
Engines, transmissions, gearshift	34–35	<b>Assistance and safety systems</b>	<b>68–69</b>
Frame, chassis, suspension	36–37		
Sector-specific vehicle concepts	38–39	<b>Genuine accessories</b>	<b>70–71</b>
Antos Loader	40		
Antos Volumer	41		









# Mercedes-Benz distribution transportation.

**Distribution transportation has its very own set of rules.** This is why we have created the Atego, for distribution transportation from 6.5 to 16 t, and the Antos, for distribution transportation from 18 t, to ensure that you are ideally placed to meet the challenges facing this sector.

With the Atego you have the perfect vehicle for the demands associated with activities such as landscaping, furniture transport, refrigerated transport or general cargo distribution. And with the Antos, you can work extremely efficiently in the fields of grocery and refrigerated transport, general cargo and drinks distribution, in the tanker and dry-bulk haulage sector or wherever there is a need for high-volume transport.

Both model series impress not only with a comfortable driver workplace, but also with precisely coordinated, job-matched vehicle configurations, fuel-saving, efficient technology and attractive service offers which can increase the overall cost-effectiveness further still.

Get aboard – and experience Mercedes-Benz in the distribution sector.





# The easy way to stay ahead. The Atego from 6.5–16 t.

**Value.** At first glance – and after thousands of kilometres: The Atego impresses in every respect. Because it has the attributes that make all the difference: these include its high quality, its outstanding reliability and its durability. The high level of driving comfort and the design optimised for convenience in the course of everyday work, the efficient, environmentally sound drive technology and the very good body-mounting ability are further advantages. These underline the value of the Atego and make it the first choice in the field of light distribution operations.

**At work.** To enable the Atego to be tailored as closely as possible to its field of work, it is available with four cabs and three cockpit variants. All the cabs offer well thought-out ergonomics, a high level of comfort and convenience and make working in and with Atego particularly easy.

When it comes to the drive system, too, the Atego has a number of essential advantages: economical, high-torque Euro VI engines and the Mercedes PowerShift 3 automated gearshift system whose different driving programs help optimise it in line with the requirements of its field of operation. A wide range of transmission and axle combinations completes the picture. Plus, there is the safe, superior handling which you can count on to help you cope safely with challenging driving situations and manoeuvres. Further advantages offered by the Atego: Long maintenance intervals, the repair and maintenance-friendly vehicle concept and the very good body-mounting ability. As you can see – with the Atego you are ideally equipped for light distribution operations. Climb aboard!





# Tailor-made – for working in light distribution operations.

The best possible way to prepare for operating in the 6.5–16 t distribution sector: an ideally designed driver workplace with impressive ergonomics and comfort. What's more, high-torque Euro VI engines, the Mercedes PowerShift 3 automated gearshift and effortlessly assured handling make it particularly enjoyable, too.

**At work.** In the Atego you have a truck with a wealth of job-matched features designed to make light work of distribution transport operations.

Apart from lending the Atego a striking, distinctive appearance, the four 2,300 mm wide cabs come up trumps on the inside, too: To enable the Atego to be tailored more specifically to the particular type of work involved, it is available with three different cockpit variants which provide for a high standard of driving comfort and ergonomic quality in conjunction with the instrument cluster, the multifunction steering wheel and the comfortable seats. All the controls and stowage facilities are positioned for maximum convenience and enable simple handling inside the vehicle.

The strengths of the Atego also become apparent as soon as the vehicle takes to the road. Highlights here include the precise steering and rear axle guide, the Mercedes PowerShift 3 automated gearshift system and the high-torque yet fuel-saving 4 and 6-cylinder in-line engines.

Mindful that distribution transport operations involve many different types of applications for vehicles, the Atego also offers a level of body-mounting ability designed to cover virtually any need. This is ensured by a wide range of factors, including its electrics and electronics concept and an extremely diverse array of factory-fitted pre-installations.

All in all: with the Atego you are outstandingly well prepared for daily operations in the distribution transport sector from 6.5–16 t. Today and tomorrow.

<sup>1)</sup> Availability dependent on gross vehicle weight.



**Low entrance.** The low entrance is typical of the way in which the Atego accommodates operational needs: one or two steps<sup>1)</sup>, wide-opening doors and grab handles on both sides afford easy, safe and convenient access to the cab.

# A motivating working environment that's well-matched to the job. The Atego cabs.

At first glance and in every detail – the four cabs for the Atego embody all the qualities required for success in the distribution sector up to 16 t: three cockpit variants, well thought-out ergonomics, a high standard of driving comfort and convenience as well as a wealth of practical details.

**ClassicSpace L-cab.** Thanks to its spacious interior and the comfort bunk, the cab also offers plenty of comfort and freedom of movement for long runs lasting more than one day. The very spacious interior makes the driver's task easier while the bottom comfort bunk makes for pleasant rest periods. Numerous stowage facilities and compartments make it easy to keep the cab tidy.

**ClassicSpace S-cab, extended.** The cab offers a comfortable workplace with a well-organised layout and compact exterior dimensions. Additional space is provided as the rear wall has been moved back by 180 mm.

**ClassicSpace S-cab.** Thanks to its dimensions, the ClassicSpace S-cab reconciles a comfortable workplace with a well-organised layout and a full-length body.



ClassicSpace S-cab

**BigSpace L-cab.** Thanks to its interior height of 1,910 mm, the cab also offers plenty of comfort and freedom of movement for long runs lasting more than one day.



BigSpace L-cab.



**Cockpit variants.** The different cockpit variants for the Atego are also tailored closely to operational needs. All three are notable for the ergonomic layout of all the controls and a practical array of stowage facilities, with a 320 mm engine tunnel making access easy.

**Standard cockpit.** From the cupholder within reach of the driver to the power socket: everything in the cab is designed to make the job of the driver in the distribution sector easier and more pleasant.

**Comfort in detail.** The Atego provides you with a wide range of practical and comfort-enhancing functions. The line-up includes convenient brief turn signals, for example, a warning

**Classic cockpit.** This cockpit variant is outstandingly well suited for use in the distribution sector thanks to its convenient through-cab access and numerous stowage facilities. Everything is arranged ergonomically and within the driver's reach. Soft surfaces create an ambience of high quality.

tone for parking brake and lights, cruise control operation using the buttons on the multifunction steering wheel and “follow me home” lights. In short, a host of functions to make everyday life with the vehicle more pleasant.

**Pre-installation for reversing camera.** The reversing camera offers greater safety and comfort – when manoeuvring, for example. The pre-installation allows it to be retrofitted. The image is displayed in the instrument cluster.

**Comfort cockpit.** With its projecting stowage unit below the instrument support, this cockpit offers additional stowage space to complement the already generous array of stowage facilities. This means that there is a place to stow everything, even on the longest trips.



**Workplace Atego.** The workplace in the Atego provides a relaxed work environment conducive to good concentration. This is the result of a number of factors: from the comfortable seats to the multifunction steering wheel and on-board computer with integrated departure check to the ergonomic layout of all the stowage facilities and controls.

**10.4 cm instrument cluster.** With its numerous new functions and displays, the on-board computer presents all the key information quickly, comprehensively and clearly.



**Multifunction steering wheel.** With eight control buttons on both the right and left, it is possible to control many functions. For example, telephone calls can be answered, assistance systems can be operated and radio settings can be adjusted.

**Mercedes PowerShift 3.** Superior dynamic response, simple handling and low fuel consumption: The 6 or 8-speed automated transmission ensures precise gear selection, short shift times, high driving comfort and optimal economy.



**12.7 cm instrument cluster with video function.** For even greater convenience and safety, this instrument cluster is prepared for use with a reversing camera. This allows the driver to see the area behind the vehicle.



**Radios.** For good entertainment the Atego can be fitted with a CD radio, a CD radio with Bluetooth® or the CD radio Comfort with Bluetooth®. All are provided with a USB and Aux-in socket.



**Manual gearshift.** As well as the automated transmission, a manual gearshift with pneumatic shift force assistance is available. It features outstanding ergonomics and extremely precise shifting while requiring only a low shift force.

**Seats.** All the seats impress with a high level of comfort. The controls are arranged intuitively, the seat cushions are particularly wide and the adjustment range particularly large: lengthwise up to 250 mm, for height up to 120 mm.

**Driver's suspension seat, standard.** The air-suspended seat features a high level of seating comfort, numerous adjustment options and a flat-weave fabric cover.

**Air-conditioned suspension seat.** The air-suspended, climatised driver's suspension seat provides pleasant seating conditions and a high level of comfort. The integral armrests and the seat heating also contribute to this.



**Comfort suspension seat.** The air-suspended seat can be adjusted to meet the needs of the individual driver and offers very good ergonomics as well as a high level of comfort. The integrated seat heating system also contributes to this.

**Heating and ventilation system.** The Atego is equipped with a powerful and fast-acting air-controlled heating and ventilation system.

**Hot-air auxiliary heating.** The auxiliary heating system is available to complement the heating system in the cab. It can be operated as a stationary heater or to reinforce the vehicle's heating system.



**Pre-installation for multimedia use.** The universal pre-installation allows mobile phones, MP3 players or commercially available navigation systems to be integrated easily; speech output is routed through the vehicle loudspeakers.



**Diffuser nozzle.** It prevents the side windows from misting or freezing in winter and can provide the driver with a cool airflow in summer.



**Stowage facilities and compartments.** The stowage concept meets the most diverse requirements, making it easier to keep the cab tidy and so maintain a high level of organisation and efficiency. From the large shelf on the instrument support to the stowage facilities in the cockpit, on the engine tunnel and in the door lining – all are optimised for the items to be accommodated. For example, for sunglasses, drinks, delivery documents and oddments such as pens.

**ClassicSpace L-cab stowage compartments.** In addition to the stowage facilities in the cockpit, in the doors and on the engine tunnel, the ClassicSpace L-cab is equipped with stowage compartments above the windscreen and under the bunk.

**Stowage facility above windscreen, 2 compartments.** The two compartments are situated above the windscreen and can be reached easily from the driver's and co-driver's seat. In conjunction with FleetBoard<sup>11</sup> the compartment closest to the driver is occupied.

**Stowage tray, low.** Can be fitted on the engine tunnel between the driver's and co-driver's seats and is equipped with two cupholders and an ashtray receptacle.



**Coolbox on engine tunnel.** Bottles and food can be stored separately in the coolbox fitted on the engine tunnel. The lid also serves as a document holder and as a step for accessing the top bunk.



**BigSpace stowage compartments.** The three large stowage compartments above the windscreen in the BigSpace L-cab have interior lighting, an anti-slip felt lining and can be equipped with hinged flaps. The open stowage facilities directly beneath them round off the available stowage space, ensuring that things can be kept even tidier.



**Stowage facility, high.** With a capacity of 15 l, it provides space for items required in the course of everyday work and so helps keep the cab tidy. Furthermore, it enables safe access to the upper bed.

**Seat/bunk combination.** The flexible seat/bunk combination can be configured to offer either sleeping accommodation for one person or seating with a continuous backrest for up to four people.

**Comfort bed, top, wide, with levelling control.** Very high levels of comfort for relaxing and sleeping are offered by the upper comfort bed with its 5-zone cold foam mattress.

**Bottom bed.** In the extended S-cab, the bottom 750 mm wide bed with a 70 mm thick cold foam mattress provides a high degree of comfort when resting or sleeping.

**Mattresses.** Restful sleep is assured by the 7-zone cold-foam comfort mattress. Even greater comfort is provided by the PremiumComfort multizone mattress which is available for both the upper and the lower bed.

**Stowage net on rear wall.** This additional stowage facility increases the amount of stowage space in the cab.

<sup>1)</sup> Available as an option.



**Comfort bed, bottom.** A one-piece, high-quality, 110 mm thick cold foam mattress with 7 zones and a sprung base provides individual support for the different parts of the body while also ensuring efficient under-mattress ventilation.

- i** At work/Cab, equipment – advantages at a glance.
- Four cabs and three cockpit variants for trucks tailored specifically to operational needs
  - Ergonomically designed workplace
  - Clearly legible instrument cluster with 10.4 cm TFT colour display or instrument cluster with 12.7 cm TFT colour display, video function as well as pre-installation for a reversing camera
  - On-board computer with departure check
  - Multifunction steering wheel which can be operated intuitively
  - Mercedes PowerShift 3 automated gearshift for better handling or manual shifting<sup>1)</sup> with shift force assistance
  - Comprehensive line-up of wide, comfortable seats with a wide adjustment range
  - Air-controlled heating and ventilation system
  - Air conditioning system as well as hot-air auxiliary heating
  - Comprehensive stowage concept
  - Wide range of radios as well as multimedia interface
  - Comfortable beds in ClassicSpace and BigSpace L-cab

# A winning team. On every trip.

Our efficient 4 and 6-cylinder engines have high output and low fuel consumption – and you can continue to benefit from these qualities in the most demanding situations with the help of the Mercedes PowerShift 3 automated gearshift.

**Engine and exhaust technology.** Powerful, reliable, economical – the Atego’s Euro VI engines are characterised by responsiveness, pulling power and very smooth running. The high environmental compatibility of the Euro VI in-line engines stems from features such as the highly efficient fuel combustion with a low level of soot particles and the cooled exhaust gas recirculation.

**Engine brake.** The three-stage braking system with up to **235 kW** of braking power reduces wear on the service brake while increasing safety and vehicle control. The three-stage auxiliary brake with up to **300 kW** of braking power<sup>1)</sup> is available for even greater safety.

**Transmission variants.** The Atego is available with a choice of 6, 8 or 9-speed transmissions, enabling the vehicle to be tailored effectively to its intended field of deployment. In conjunction with the perfectly matched rear-axle ratios, it offers an economical drive.

**Mercedes PowerShift 3.** Superior dynamic response, simple handling and low fuel consumption: The 6 or 8-speed automated transmission ensures precise gear selection, short shift times, high driving comfort and optimal economy. The “economy” transmission mode supports a particularly economical driving style. In the “power” transmission mode, the speed for all shift operations is increased by 100 rpm so that the engine output is available for longer.

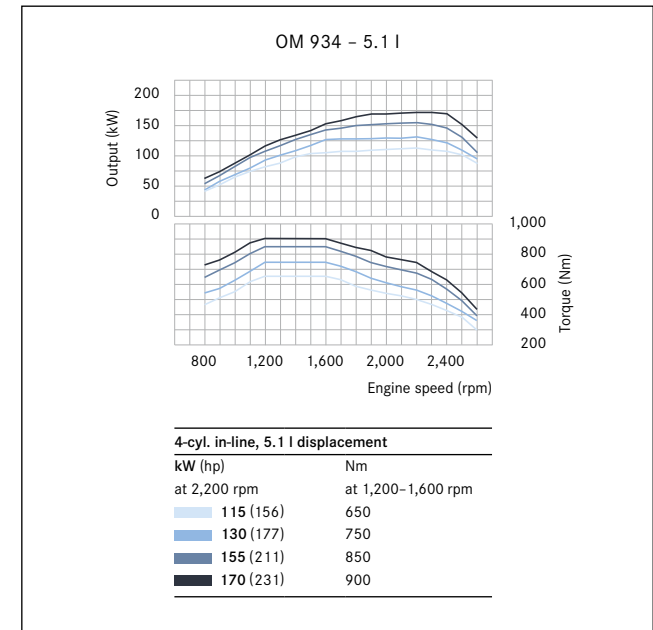

**Reduced displacement, increased power.** With an output of up to **170 kW** (231 hp) and maximum torque of 900 Nm, the Atego’s 4-cylinder in-line engines boast performance data which were previously the reserve of 6-cylinder engines.



**Economy driving program.** The driving program can be activated selectively and supports a particularly economical driving style. It is a functional addition to the “standard” transmission mode.

**Power driving program<sup>2)</sup>.** The driving program supports an agile driving style in challenging terrain. In “power” transmission mode, the engine speed for all shift operations is increased by 100 rpm compared with “standard”. This makes the full engine output available for longer.

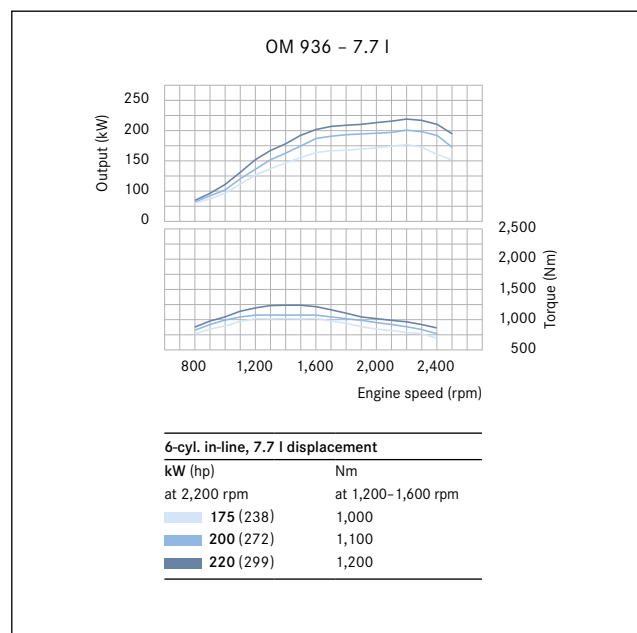

**More power, more torque.** With an output of up to **220 kW (299 hp)** and maximum torque of 1,200 Nm, the 6-cylinder in-line engines in the Atego provide just the power you need for your operations.

**Additional functions.** With Mercedes PowerShift 3, additional functions, such as direct shifting from “forward” to “reverse” as well as high-ratio reverse gears make for easy manoeuvring. The crawler function is particularly convenient when moving off.

Driving program	power			
	economy			
Transmiss. mode	economy	standard	manual	power
	No kickdown possible EcoRoll cannot be deactivated Top speed <sup>3)</sup> 85 km/h	Kickdown possible EcoRoll can be deactivated Top speed 89.8 km/h	No kickdown possible EcoRoll can be deactivated Top speed 89.8 km/h	Kickdown possible EcoRoll deactivated Top speed 89.8 km/h

**Atego driving programs.** The Atego is available with the two driving programs “economy” or “power”, one of which you can select at the time of purchase. Different transmission modes enhance driving comfort and efficiency.

**i** At work/Engines, transmissions – advantages at a glance.

- More fuel-efficient, reliable 4- and 6-cylinder in-line engines with high torque at low engine speeds
- Two displacement classes, seven power variants from 115 kW (156 hp) to 220 kW (299 hp)
- Powerful engine brake or High Performance Engine Brake
- Choice of 6, 8 and 9-speed transmissions for drive systems geared specifically to the intended area of application
- Mercedes PowerShift 3 automated gearshift with “economy” or “power” driving programs as well as selectable transmission modes and additional functions

<sup>1)</sup> Depending on engine variant.

<sup>2)</sup> Alternative at no extra cost.

<sup>3)</sup> Top speed of 89.8 km/h possible using the accelerator.



# Efficient working, effortless driving. The Atego has what it takes.

The Atego has a whole range of practical advantages in store: it helps you work efficiently, it handles extremely well and has very good body-mounting ability. Qualities which represent pretty much everything you need in a distribution vehicle. And which you won't want to do without once you've tried it.

**Ride comfort.** The Atego provides a very pleasing, superior driving feel. This is based on Stability Control Assist, the cab suspension, the rear-axle guide and the vehicle suspension, all of which work together perfectly.

**Suspension variants.** The Atego is equipped with weight-optimised single- or multi-leaf parabolic springs. For enhanced ride comfort, a combination of steel and air suspension is also available while models over 12 t are available with full air suspension.

**Cab suspension, rear, reinforced.** The cab suspension with reinforced coil springs at the rear contributes to the suspension comfort offered cabs with steel suspension if the cab is equipped with a seat/bunk combination, for example.



**Precise steering.** The responsive steering of the Atego provides for simple, exact handling during manoeuvring and for reliable straight-line stability and high directional stability at high speeds – thus requiring less corrective action on the part of the driver.



**Atego rear axle guide.** For superior handling, air-sprung Ategos up to 10.5 t and 12 t with low frame as well as all Ategos with steel suspension are fitted with a rear-axle guide that reduces roll understeer.

**Air-suspended front axle.** The air-suspended front axle increases the driving comfort as the vehicle level is automatically adjusted to compensate for an unevenly distributed load. When loading, it also adjusts to the height of the ramp.

**Atego – good body-mounting ability.** An important factor in the very good body-mounting ability is the parameterisable special module, which greatly simplifies the connection, integration and subsequent operation of mounted bodies. Furthermore, a whole range of measures – from the optimised positioning of all components on the frame to numerous factory-fitted pre-installations – helps to ensure that the Atego is back in your hands and therefore back in operation more quickly.



**Stabiliser, rear axle.** The robust stabiliser reduces vehicle roll and thus offers greater safety and comfort. It is situated under the frame at the rear axle.

**Tail lift package.** The tail lift package comprises all the pre-installation measures necessary for retrofitting a tail lift.

**Engine power take-off, front, pre-installation for AW30 refrigeration generator.** The pre-installation allows retrofitting of the AW30 generator to supply the electricity required by an on-board refrigeration system.



**Parameterisable special module.** The optional parameterisable special module (PSM) ensures perfect information processing and a smooth exchange of data between vehicle and body.



**At work/Driving comfort, body-mounting ability – advantages at a glance.**

- Superior driving comfort, very good body-mounting ability
- Stability Control Assist
- 4-point cab suspension
- Low roll understeer thanks to optimised rear axle guide<sup>1)</sup>
- Direct, responsive steering for high directional stability and low requirement for corrective action on the part of the driver
- Suspension variants tailored to different types of application: steel, steel/air or all-air suspension for high driving comfort and load protection
- Excellent body connection facilities and body integration
- Cost-saving ex factory pre-installation solutions

<sup>1)</sup> For air-suspended Atego up to 10.5 t and 12 t with low frame as well as all Ategos with steel suspension.





## The Atego – cab variants

### S-cab

#### ClassicSpace S-cab

Exterior width: 2,295 mm

Exterior length: 1,650 mm

Interior width: 2,000 mm

Interior height: 1,510 mm

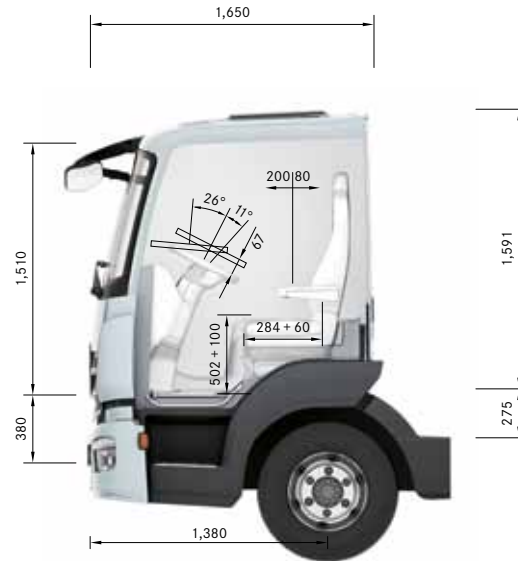

ClassicSpace S-cab



ClassicSpace S-cab

#### ClassicSpace S-cab, extended

Exterior width: 2,295 mm

Exterior length: 1,830 mm

Interior width: 2,000 mm

Interior height: 1,510 mm

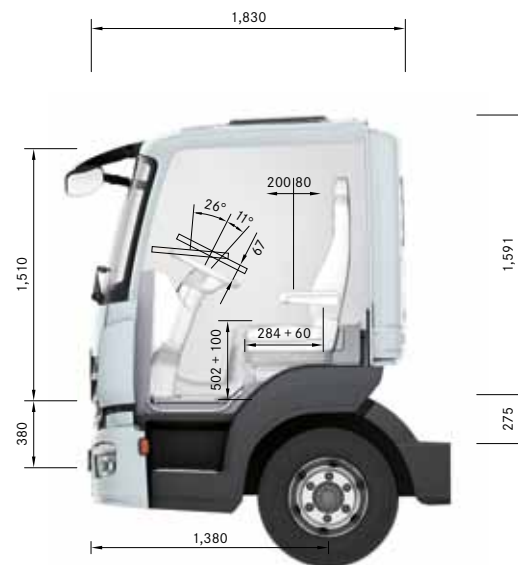

ClassicSpace S-cab, extended



ClassicSpace S-cab, extended

## L-cab

### ClassicSpace L-cab

Exterior width: 2,295 mm  
 Exterior length: 2,250 mm  
 Interior width: 2,000 mm  
 Interior height: 1,510 mm

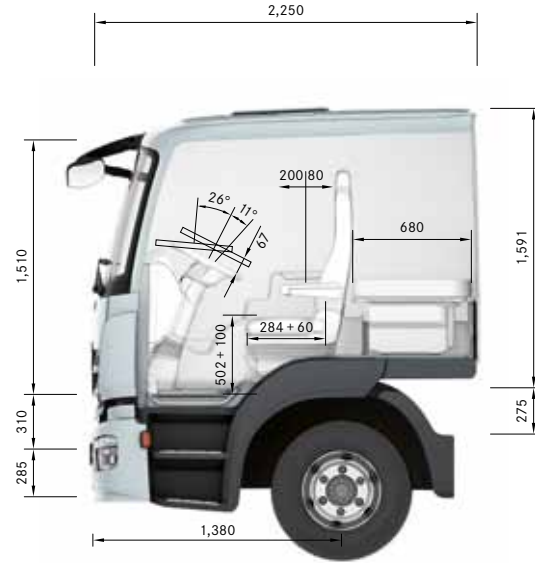

ClassicSpace L-cab



ClassicSpace L-cab

### BigSpace L-cab

Exterior width: 2,295 mm  
 Exterior length: 2,250 mm  
 Interior width: 2,000 mm  
 Interior height: 1,910 mm

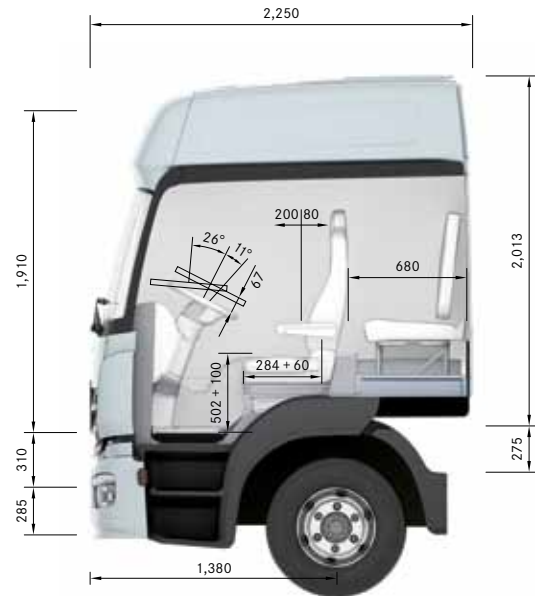

BigSpace L-cab



BigSpace L-cab

The Atego – model overview									
Gross vehicle weight	6.5	7.49	7.99	9.5	10.5	11.99 <sup>1)</sup>	13.5	15	
Wheel configuration	4x2	4x2	4x2	4x2	4x2	4x2	4x2	4x2	4x2
Suspension	Steel	Steel	Steel	Steel	Steel	Steel	Steel	Steel	Steel
<b>Engines</b>									
<b>OM 934</b>									
115 kW (156 hp)	x	x	x	x	x	x <sup>2)</sup>	–	–	–
130 kW (177 hp)	–	x	x	x	x	x	x	x	x
155 kW (211 hp)	–	x	x	x	x	x	x	x	x
170 kW (231 hp)	–	x	x	x	x	x	x	x	x
<b>OM 936</b>									
175 kW (238 hp)	–	–	x	x	x	x	x	x	x
200 kW (272 hp)	–	–	–	–	–	x <sup>3)</sup>	x	x	x
220 kW (299 hp)	–	–	–	–	–	x <sup>3)</sup>	x	x	x
<b>Wheelbase</b>									
3,020 mm	x	x	x	x	x	–	–	–	–
3,320 mm	x	x	x	x	x	–	–	–	–
3,560 mm	–	–	–	–	–	x <sup>3)</sup>	x	x	x
3,620 mm	x	x	x	x	x	x <sup>2)</sup>	–	–	–
4,160 mm	–	–	–	–	–	x <sup>3)</sup>	x	x	x
4,220 mm	x	x	x	x	x	x <sup>2)</sup>	–	–	–
4,760 mm	–	–	–	–	–	x <sup>3)</sup>	x	x	x
4,820 mm	–	x	x	x	x	x <sup>2)</sup>	–	–	–
5,360 mm	–	–	–	–	–	x <sup>3)</sup>	x	x	x
5,420 mm	–	–	–	–	–	x <sup>2)</sup>	–	–	–
5,960 mm	–	–	–	–	–	x <sup>3)</sup>	–	–	–
6,260 mm	–	–	–	–	–	x <sup>3)</sup>	x	–	–
<b>Cab variants</b>									
ClassicSpace S-cab	x	x	x	x	x	x	x	x	x
ClassicSpace S-cab, extended	x	x	x	x	x	x	x	x	x
ClassicSpace L-cab	x	x	x	x	x	x	x	x	x
BigSpace L-cab	x	x	x	x	x	x	x	x	x







# Heavy-duty distribution made easy. The Antos from 18-44 t.

**Handling.** The Antos has been specially developed for distribution work from 18 t upwards, in order to meet all your requirements in such fields as grocery and refrigerated transport or in the tanker and dry-bulk haulage sector: A wide choice of cab variants means that the product line-up is able to meet practically any requirement with regard to body length, payload, interior space and the driver's overall view. What's more, the ergonomic driver workplace with its comfortable seats which maintain driver fitness, its multifunction steering wheel and its clearly legible instrument cluster enables simple, precise operation and handling. Mercedes PowerShift 3, responsive Euro VI engines, application-matched transmission and axle combinations as well as the finely tuned chassis make it a pleasure to drive.

**Industry-specific vehicle concepts.** When it comes to particularly cost-effective transport in sectors where payload and load volume are all-important, the Antos Loader and Volumer have all the answers. The Antos Loader has been systematically designed as a payload-focused vehicle – it is simply built to carry more. It doesn't matter whether you are transporting grain or gas. The Antos Volumer stands for a huge transport capacity – allowing, for example, supplier parts for the automotive industry or white goods, such as refrigerators or washing machines, to be transported particularly efficiently.





# Perfect handling: time, load and vehicle – all under control.

The Antos has practically everything necessary to make your daily work in the distribution sector from 18 t more pleasant: a comfortable, practical work environment, a dynamic drive system with fast response times and impressive handling performance.

**Handling.** The ClassicSpace S, ClassicSpace M and the CompactSpace M cabs have the ideal credentials to enable you to meet the ever-growing challenges of day-to-day operation quickly, easily and comfortably. This is because they are systematically geared towards the specific application, allowing them to offer an excellent balance between body length, payload capacity and a comfortable, practical workstation. The standardised width of 2,300 mm provides an optimum overall view for the driver, while the low, stair-like entrance takes the strain out of getting in. The comfortable driver's seat and the asymmetrically designed cockpit that is angled towards the driver instantly give you a feeling of complete control. In short, Well thought-out ergonomics, intuitive controls as well as practical stowage facilities together form a harmonious overall concept, which simply makes your job easy.

The highly responsive, dynamic drive in the Antos also makes a winning impression from the word go. Working in unison with the Mercedes PowerShift 3 automated gearshift and the application-matched transmissions and rear-axle ratios, the high-torque Euro VI engines are able to deliver a tangible sense of dynamism and economical driving pleasure in virtually any driving situation. Besides this, the direct and responsive steering, the wide frame, the 4-bellows air suspension and the rear-axle guide<sup>1)</sup> work together in perfect harmony to produce a particularly assured and solid driving feel. Just as much on a country road as in the city or when manoeuvring. Furthermore, the driver is supported by an extremely diverse array of safety and assistance systems. For noticeably better handling. On every trip.

<sup>1)</sup> Only available for 4x2 model variants.



**The easy way to get in.** The ergonomic, stair-like arrangement of the non-slip steps allows for convenient access to the cab without any great exertion and is just one example of how the Antos makes the driver's task easier.

# Instead of compromises: six cab variants that impress – and delight.

Fine-tuned to the requirements of drivers and their companies, with no compromises: the three cabs for the Antos, each of which can be specified with an engine tunnel height of 170 mm or 320 mm, have been honed to perfection to meet the demands of their respective fields of application. So you can benefit from their efficient operation and straightforward handling. From morning to night. On every trip.

**ClassicSpace S-cab.** Measuring 2,300 mm in width and 1,700 mm in length, and shown here with a 320 mm engine tunnel, the cab is designed to meet all the requirements associated with one-person operation in the distribution, short-range transport and construction sectors.



ClassicSpace S-cab

**ClassicSpace M-cab.** Measuring 2,300 mm in width and 2,000 mm in length, shown here with a 170 mm engine tunnel, the cab is suited to almost every application. The bunk also offers greater comfort, even during one-day runs.



ClassicSpace M-cab

**CompactSpace M-cab.** Measuring 2,300 mm in width and with a flat roof, the cab is designed to meet all the requirements associated with one-person operation in the distribution sector where low overall height is essential.



CompactSpace M-cab



**Workplace Antos.** The Antos has a practical and comfortable driver's workplace which also serves as an information and command centre at the same time. The optimal cockpit is centred around the driver and is designed for optimum usability in all situations: the main vehicle functions can be controlled conveniently and safely using the multifunction steering wheel. The automated gearshift is operated by means of the right-hand steering-column lever. Similarly, all the other control elements, the radio, as well as the handy stowage facilities are positioned ergonomically within the driver's reach. In short, it's the ideal environment for focused working, relaxed driving and precise operation. Furthermore, the Antos can be matched even more closely to your individual requirements by means of one of the three Comfort Packs which are available ex factory.

**Multifunction key.** It offers all the functions of an extended central locking system and allows the tyre pressure and lighting checks to be carried out. The optional key also serves as a remote control for features such as the radio and the auxiliary heating.

**Two remote-control keys.** Two remote-control keys can prevent delays because of a mislaid key or allow two drivers to access the vehicle independently of each other.



**Engine start/stop button.** One finger is all it takes to start and stop the engine: just press the engine start/stop button – that's all there is to it.

**Mirror with manoeuvring function.** The co-driver's mirror with manoeuvring function is matched to the requirements of the job and is extremely user-friendly. It makes it easier to view the semitrailer or trailer when it matters most – when manoeuvring the vehicle.



**10.4 cm instrument cluster.** With its numerous new functions and displays, the on-board computer presents all the key information quickly, comprehensively and clearly.

**Leather steering wheel.** The optional high-quality 4-spoke leather steering wheel with a diameter of 450 mm contributes to the comfort of the vehicle interior and gives it an individual touch.

**CD radio.** The combined radio/CD player with a single-line display provides entertainment en route and is easy to operate. It is integrated in the instrument support and designed to run on the vehicle's 24-volt electrical system.



**Bluetooth® Radio Navigation System.** Equipped with a 17.4 cm colour display as well as Bluetooth® and convenience features, the system leaves nothing to be desired when it comes to support for the driver and entertainment.



**Instrument cluster with additional displays.** The 10.4 or 12.7 cm instrument cluster with TFT colour display provides a detailed presentation of all vehicle functions. It impresses with its clearly legible, non-reflective display and intuitive user interface.



**Multifunction steering wheel.** With eight control buttons on both the right and left, it is possible to control many functions. For example, telephone calls can be answered, assistance systems can be operated and radio settings can be adjusted.



**Adjustment range.** Thanks to the large adjustment range, the multifunction steering wheel can be tilted to an almost vertical position. This means that it is easier to get in and out of the cab and that interior space can be freed up during breaks.

**Seats.** All the seats impress with a high level of comfort. The controls are arranged intuitively, the seat cushions are particularly wide and the adjustment range particularly large: lengthwise up to 250 mm, for height up to 120 mm.

**Driver's suspension seat, standard.** The air-suspended seat features a high level of seating comfort, numerous adjustment options and a flat-weave fabric cover.

**Fold-up co-driver's seat.** The spacious, 540 mm wide seat cushion can be folded up manually and locked. In this way, the driver has more space during breaks as well as convenient through-cab access to the co-driver's door.

**Air-conditioned suspension seat.** The air-suspended, climatized driver's suspension seat provides pleasant seating conditions and a high level of comfort. The integral armrests and the seat heating also contribute to this. The active ventilation system in the backrest and cushion of the climatized suspension seat reduces heat and moisture build-up. The numerous individual adjustment options make for optimal ergonomics.

**Centre seat<sup>1)</sup>.** Thanks to the additional seat between the driver's workplace and the co-driver's seat, more people can be carried in the vehicle. It has an adjustable backrest as well as an integral head restraint and an integral 3-point seat belt. The centre seat with seatbelt is fitted on the engine tunnel.

<sup>1)</sup> Available for the ClassicSpace S-cab and M-cab.



**Comfort suspension seat.** The air-suspended seat can be adjusted to meet the needs of the individual driver and offers very good ergonomics as well as a high level of comfort. The integrated seat heating system also contributes to this. As well as being pneumatically adjustable for height, cushion inclination and depth, the comfort suspension seat is equipped with an integral head restraint and an integral, height-adjustable 3-point automatic seat belt.

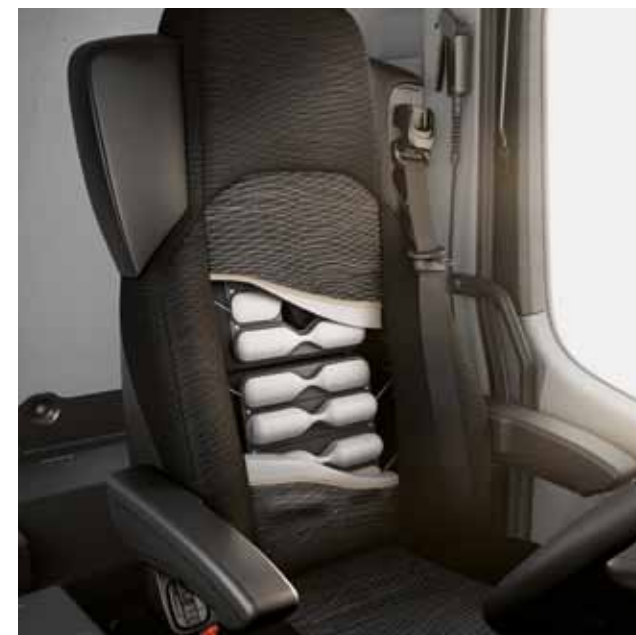

**Massage function for driver's seat.** The comfort features prevent the driver from suffering from muscular tension problems. So their comfort is maintained for longer.



**Handy stowage facilities for everything.** As well as keeping the cab tidy and easy to manage, the stowage concept in the Antos can be adjusted to meet the individual driver's requirements. From the large shelf on the instrument support to the stowage facilities in the cockpit and in the door lining as well as the low or high stowage facility on the engine tunnel, not forgetting the options of enclosed stowage box with an integral litter bin, a stowage pocket for the rear wall and a CD holder for up to 6 CDs – all the stowage facilities in the Antos are optimised for the items to be accommodated. The coat hooks mean you always have somewhere to hang up your jacket.

**Stowage space behind the seats.** With a capacity of 230 litres, the stowage compartments behind the seats of the M-cabs offer plenty of space. Especially practical: the stowage compartment on the driver's side is accessible from the interior and the exterior.

**Hot-water auxiliary heating.** The heating system is fitted in the engine compartment. This reduces the noise level and creates more space in the cab. The heater allows the windows to be defrosted before the start of the journey.

**Bottom bunk.** Available for M-cabs, the bottom bunk provides a high level of comfort when resting or sleeping, whether in the course of all-day trips or overnight stops.



**Door compartment.** The stowage bins in the interior door trim offer space for items such as work gloves which should be kept within easy reach without having to climb into the cab. Each one also incorporates a bottle holder large enough for a 1.5 l bottle.



**Table, on co-driver's side.** The optional folding table is integrated in the instrument support and can be folded out and in again quickly for working or eating.



**Heating, ventilation, climate.** The Antos is equipped with a fast-acting air-controlled heating system. For even greater ease of use and comfort, an air conditioning system or an automatic climate control system can be specified. What's more, the residual engine heat utilisation system or various versions of the hot-water auxiliary heating system can maintain a pleasantly warm temperature during breaks, for example.



**Exterior storage compartment.** Also accessible from the interior, the exterior storage compartment on the driver's side of the M-cab is able to hold tools and other items essential in the course of heavy-duty distribution work.



**Refrigerator on engine tunnel.** The coolbox provides the driver with cold drinks and food. It can be reached easily from the driver's seat and makes the driver less dependent on service areas.



**Storage flaps above windscreen.** The flaps prevent objects from falling out of the storage compartments and protect the contents from prying eyes. The storage compartment interior lighting, which is included as standard, is switched on automatically when the storage compartments are opened.

**i** Handling/Working – advantages at a glance.

- Excellent handling thanks to ergonomically designed driver workplace
- Intuitively controllable multifunction steering wheel with large adjustment range
- Clearly legible instrument cluster with 10.4 cm or 12.7 cm TFT colour display
- Comprehensive range of comfortable seats with particularly large cushion area and scope for adjustment
- Extensive radio and multimedia range including truck navigation
- Air-controlled heating and ventilation system with residual engine heat utilisation, air conditioning or climate control system, hot-water auxiliary heating for engine and cab
- Extensive storage concept with plenty of handy storage features that are within easy reach of the driver's seat
- Additional equipment:  
e. g. coolbox with approx. 25 l capacity, folding table on co-driver's side, centre seat, comfortable bunk in M-cab
- Comfort Pack

# Responsive, precise, efficient.

## When it comes to drive power, we've really shifted up a gear.

Euro VI engines with up to **460 kW** (625 hp) output, Mercedes PowerShift 3 and a wide selection of precision-matched transmission and axle combinations – you can feel how the inner strength of the Antos is transferred responsively, precisely and efficiently to the road. Prepare to be thrilled.

**Antos drive system.** The efficient, high-torque 6-cylinder in-line engines operate with X-Pulse common-rail high-pressure injection<sup>1)</sup> and an injection pressure of up to 2,100 bar. This saves fuel and reduces the burden on the environment. The durable, reliable design, the excellent responsiveness and the very smooth running characteristics are further advantages of the Euro VI engines used in the Antos. In conjunction with the Mercedes PowerShift 3 automated gearshift, the drive axles which are matched perfectly to it and the wide range of ratio variants, the Antos offers a dynamic, responsive drive configuration for practically every heavy-duty distribution transport task imaginable. Plus, of course, loads of driving pleasure.

**Mercedes PowerShift 3.** Superior dynamic response, simple handling and low fuel consumption: The 8, 12 and 16-speed automated transmissions ensure precise gear selection, short shift times, high driving comfort and optimal economy.

**Fleet driving program.** The fuel-saving variant of the Mercedes PowerShift automated transmission was developed for fleet customers.

**Economy driving program.** The driving program can be activated selectively and supports a particularly economical driving style. It is a functional addition to the “standard” transmission mode.

**Power driving program<sup>2)</sup>.** The driving program supports an agile driving style in challenging terrain. In “power” transmission mode, the engine speed for all shift operations is increased by 100 rpm compared with “standard”. This makes the full engine output available for longer.



**Antos engines.** With a total of 16 power ratings from **175 kW** (238 hp) up to **460 kW** (625 hp), the Antos boasts a wide range of high-torque Euro VI engines which stand out with their noticeably dynamic feel and low fuel consumption.

**Additional functions.** With Mercedes PowerShift 3, additional functions, such as direct shifting from “forward” to “reverse” as well as high-ratio reverse gears make for easy manoeuvring. The crawler function is particularly convenient when moving off.



**Information centre.** The current transmission mode and selected gear are displayed in the instrument cluster at all times – the selectable transmission modes and auxiliary functions further enhance usability and efficiency.



**Antos transmissions.** The Antos offers the right automatic transmission for practically every transport job. Along with a range of four 12-speed transmissions and a 16-speed unit, the line-up also includes a compact 8-speed transmission.

Driving program	fleet			
			power	
	economy			
Transmiss. mode	economy	standard	manual	power
	No kickdown possible	Kickdown possible	No kickdown possible	Kickdown possible
	EcoRoll cannot be deactivated	EcoRoll can be deactivated	EcoRoll can be deactivated	EcoRoll deactivated
	Top speed <sup>3)</sup> 85 km/h	Top speed 89.8 km/h	Top speed 89.8 km/h	Top speed 89.8 km/h

**Antos driving programs.** When you purchase the Antos, you can choose one of the three driving programs fleet, economy or power. Different transmission modes enhance driving comfort and efficiency.

<sup>1)</sup> X-Pulse is not available with the OM 936 engine.

<sup>2)</sup> Alternative at no extra cost.

<sup>3)</sup> Top speed of 89.8 km/h possible using the accelerator.

**i Handling/Drive – advantages at a glance.**

- Dynamic drive with responsive engines and perfectly matched powertrain configurations
- Low-consumption 6-cylinder in-line engines with X-Pulse<sup>1)</sup> common-rail high-pressure injection
- Four displacement classes: 7.7 l, 10.7 l, 12.8 l, 15.6 l
- Comprehensive range of Euro VI engines with 16 power ratings from 175 kW (238 hp) up to 460 kW (625 hp)
- Mercedes PowerShift 3 automated gearshift with individually selectable driving programs as well as driving modes and additional functions which can be selected as required
- Automated transmission conveniently operated via the steering-column lever
- Six different, application-matched transmission variants with 8, 12 and 16 speeds
- Two weight-optimised hypoid rear axles designed to suit the end application with a comprehensive choice of ratio variants





# For a superior driving feel. From the first metre to the last.

In the Antos, the frame, chassis, suspension and steering work together in perfect harmony. For easy, precise handling when driving and manoeuvring. And for an unrivalled experience at the wheel.

**Antos handling.** The Antos has particularly good roadholding and provides a superior, safe driving feel: Factors contributing to this include the wide, rigid frame, the 4-bellows air suspension, the innovative rear-axle guide<sup>1)</sup> and the direct, responsive steering.



**Precise steering.** The direct and particularly sensitive steering has speed-sensitive power assistance. This makes manoeuvring particularly straightforward, effortless and safe. And at high speeds the system supports reliable straight ahead running and the best possible directional stability. A high level of steering accuracy and very good understeer/oversteer characteristics are further advantages which contribute to more safety and outstanding capability.

**Innovative rear axle guide.** The innovative rear-axle guide<sup>1)</sup> makes for high lateral stability, low body roll, excellent understeer/oversteer characteristics and necessitates fewer steering corrections.



**Air suspension.** Mounted on the far outside, the bellows on the 4-bellows air suspension work in conjunction with the innovative rear-axle guide<sup>1)</sup> to provide an optimum roll response and minimise the roll angle when cornering.



**Antos frame.** Besides its excellent roadholding and supreme driving qualities, the Antos frame also offers outstanding corrosion protection – thanks to cathodic dip priming – and straightforward body mounting. Further benefits include the wide selection of wheelbases, factory-fitted frame overhangs and end cross members.



#### Handling/Driving – advantages at a glance.

- Perfectly harmonised chassis components for a tremendously assured and superior driving feel
- Optimised rear axle guide<sup>1)</sup> for high lateral stability and good understeer/oversteer characteristics
- 4-bellows air suspension system for impressive suspension comfort, cargo protection and reduced roll characteristics
- Direct steering with sensitive response for high steering precision
- Variable power assistance depending on the road speed
- Wide, rigid frame and therefore a wide track for excellent roadholding
- Comprehensive line-up of wheelbases, selectable frame overhangs and end cross members

<sup>1)</sup> Only available for 4x2 model variants.





# Simply more capacity: Antos Loader and Antos Volumer.

If you are looking for extra payload capacity or load space; we have the answer: the Antos Loader and the Antos Volumer – two real specialists that simply built to carry more.

**Industry-specific vehicle concepts.** The Antos is the particularly efficient solution in the distribution sector from 18 t. And so that the same can be said for high-payload and high-volume haulage too, we have developed the Antos Loader and the Antos Volumer. Because: Specialised tasks call for specialised equipment – in this case, specialised vehicles.

The Antos Loader line-up comprises payload-optimised rigids and tractor units which are among the lightest in the heavy-duty distribution sector. With powerful, economical Euro VI engines, cabs matched to the jobs they have to do and the same high standard of safety.

The Antos Volumer also makes it possible to operate even more efficiently. The rigids boast a low frame height and the tractor units stand out with their particularly low coupling point height, making them real high-volume haulage specialists. In practice, this means: the load area can be put to

optimum use. In addition to the high load capacity, powertrain configurations which are particularly economical with fuel and factors such as the large fuel tank capacity of the Antos Volumer all contribute to greater efficiency too.

In short, with the Antos Loader and the Antos Volumer, Mercedes-Benz is able to offer you vehicle configurations which are optimised for their task and which simply allow you to operate more profitably wherever there is a requirement for high-payload and high-volume haulage.

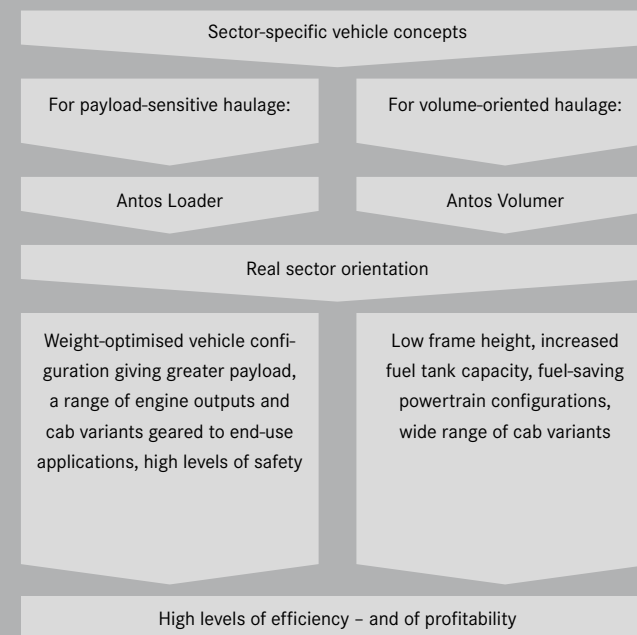



# The Antos Loader: for those who want more payload.

Less tare weight, more payload – from the radiator grille to the end cross-member. The Antos Loader was designed specifically for the requirements in industries with high payload needs. That’s why it is among the lightest vehicles in long-distance transport. Regardless of whether as a tractor unit or a rigid truck. The Antos Loader can simply carry more load. And that pays off. On every trip.

**Loader.** These are payload-optimised rigid vehicles and tractor units, which, despite the heavy Euro VI technology, weigh as little as 6,000 kg, depending on the equipment fitted. This is made possible by weight-reducing measures which enable you to carry more payload. The Antos Loader models are offered as both tractor unit and rigid, with a wide range of frugal engine options – 7.7 l or 10.8 l from **200 kW** (272 hp) up to **315 kW** (428 hp), all with 8 or 12-speed Mercedes PowerShift 3 transmissions and aluminium wheels as standard. Like all Antos models, the Loader can be specified with the full range of available safety systems.

1	Roof hatch omitted	6	Weight-optimised windscreen
2	Weight-optimised end cross member <sup>1)</sup>	7	Rear axle guide, weight-optimised (wishbone, enclosed) <sup>1)</sup>
3	Combination tank (300 l diesel and 25 l AdBlue <sup>®</sup> ) <sup>1)</sup>	8	Aluminium step brackets
4	140 Ah batteries	9	Weight-optimised floor covering
5	Dust undershield omitted	10	Radiator shutter omitted



■ Deselectable items      ■ Non-deselectable items

**Weight-reducing measures.** Many components and features of the Antos Loader have been systematically designed for use in sectors where payload is a crucial factor. To give you maximum flexibility in configuring the vehicle some measures can also be “deselected”. In short: you decide for yourself whether you wish to fully exploit the payload potential of the Loader and minimise its unladen weight.

# The Antos Volumer: for anyone needing lots of space.

Huge transportation capacity, fuel-saving powertrain configurations, a high operating range and perfectly tailored to the intended application – the Antos Volumer shows how rigid trucks and tractor units should be built today to make high-volume haulage especially profitable.



**Volumer details.** With its low frame/coupling point height, the Antos Volumer comes with the ideal credentials for economical high-volume haulage. The low frame, the comprehensive range of wheelbases, the choice of frame overhangs available ex factory and the application-matched powertrain configurations all help to give an additional boost to efficiency.

**Volumer.** As a true high-volume haulage specialist, the Antos Volumer as a platform truck offers the ability to stack three standard crates on top of each other. A wide range of tanks is available for an enormous operating range and a high level of task orientation. The mission-optimised powertrain configurations also ensure exemplary efficiency. The wide range of rear-axle ratios available means that the Antos Volumer can always be fitted with a direct-drive transmission<sup>2)</sup>. This saves up to 1% fuel compared with an overdrive transmission. In short, the Antos Volumer unites three decisive strengths in one vehicle: huge transportation capacity, flexible configuration and exceptional efficiency.

<sup>1)</sup> For 4x2 tractor units.

<sup>2)</sup> Not in conjunction with **375 kW** (510 hp) engine.

## The Antos – cab variants

**Antos cab variants.** With six variants, the Antos is able to offer just the right cab to enable efficient working and easy handling in the distribution sector from 18 t. If the full body length is required, the ClassicSpace S-cab is the top choice. The ClassicSpace M-cab is suited to longer, full-day runs, for example, while the CompactSpace M-cab makes an ideal car transporter. A good overall view and high payload capacity are common to all.

ClassicSpace S-cab

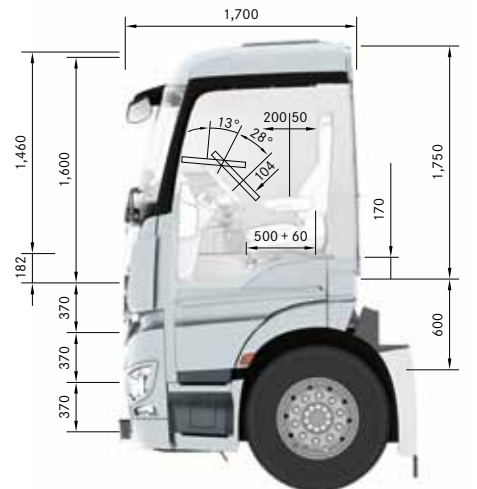

Engine tunnel: 170 mm  
Headroom over engine tunnel: 1,460 mm

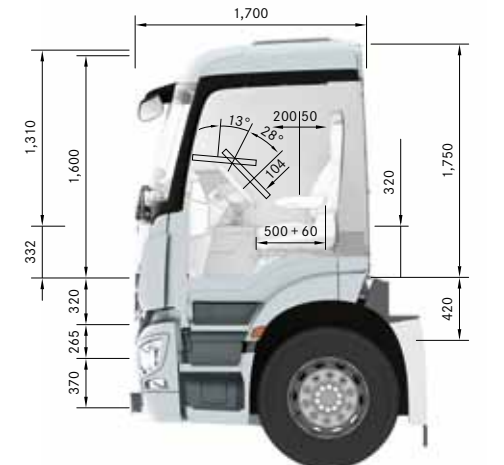

Engine tunnel: 320 mm  
Headroom over engine tunnel: 1,310 mm

### General technical data

Exterior width of all cabs: 2,300 mm

Exterior length

ClassicSpace S-cab: 1,700 mm

ClassicSpace  
and CompactSpace M-cab: 2,000 mm

Headroom in front of seats

ClassicSpace S-cab: 1,600 mm

ClassicSpace M-cab: 1,600 mm

CompactSpace M-cab: 1,400 mm



Variant with centre seat

### ClassicSpace M-cab

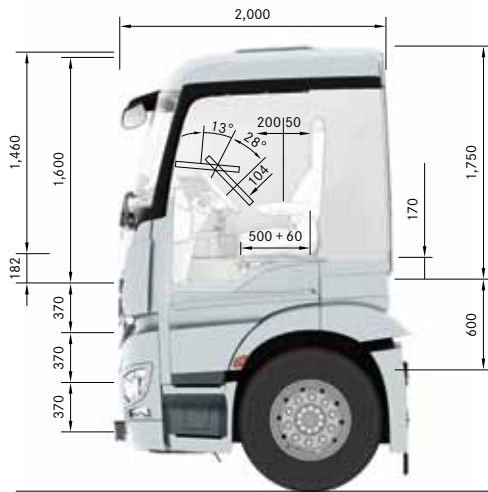

Engine tunnel: 170 mm  
Headroom over engine tunnel: 1,460 mm

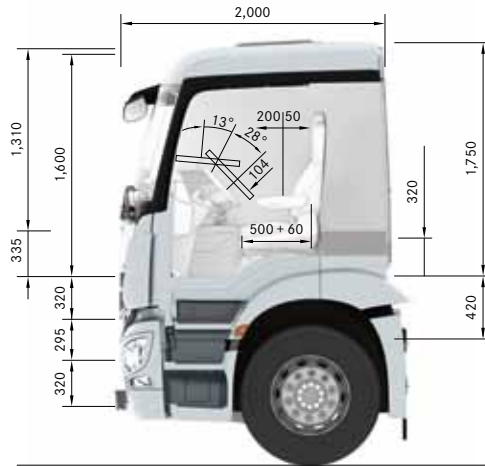

Engine tunnel: 320 mm  
Headroom over engine tunnel: 1,310 mm

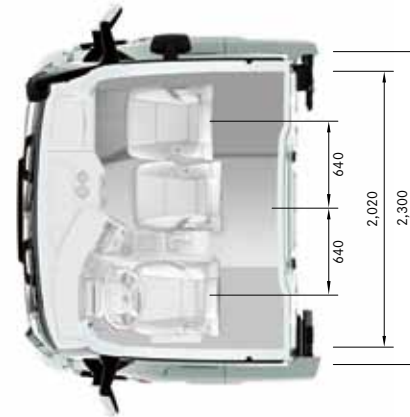

Variant with centre seat



Variant with bunk

### CompactSpace M-cab

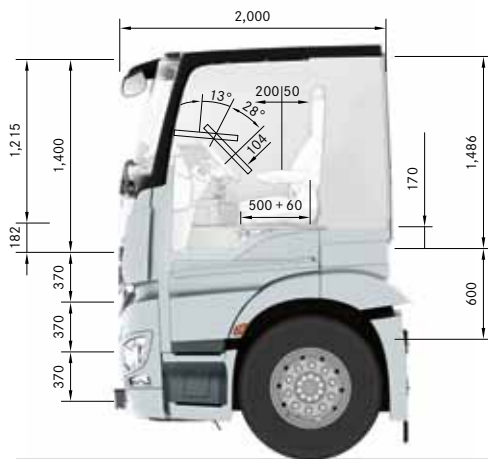

Engine tunnel: 170 mm  
Headroom over engine tunnel: 1,215 mm

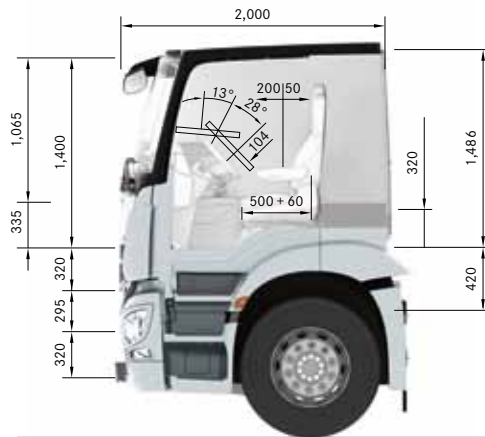

Engine tunnel: 320 mm  
Headroom over engine tunnel: 1,065 mm

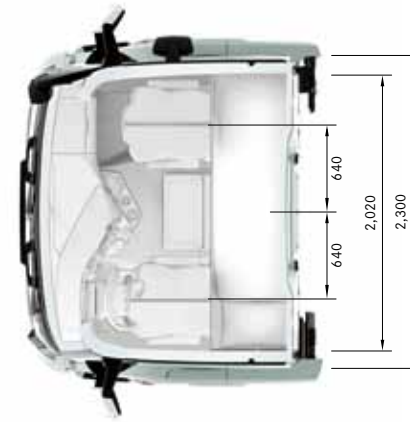

Variant with bunk



## The Antos – tank variants

**Antos tank variants.** Flexible combination options: within the same tank cross-section, different tank volumes can be combined on the left and right-hand sides. This applies to diesel and AdBlue® tanks as well as to combination tanks. The illustrations show two possible variants for a rigid vehicle and tractor unit respectively.



**Modular system for tanks.** So that it can be geared exactly to the operating profile, the new Antos can be equipped with tanks of varying heights and widths.

Example tank variant for Antos rigid vehicle

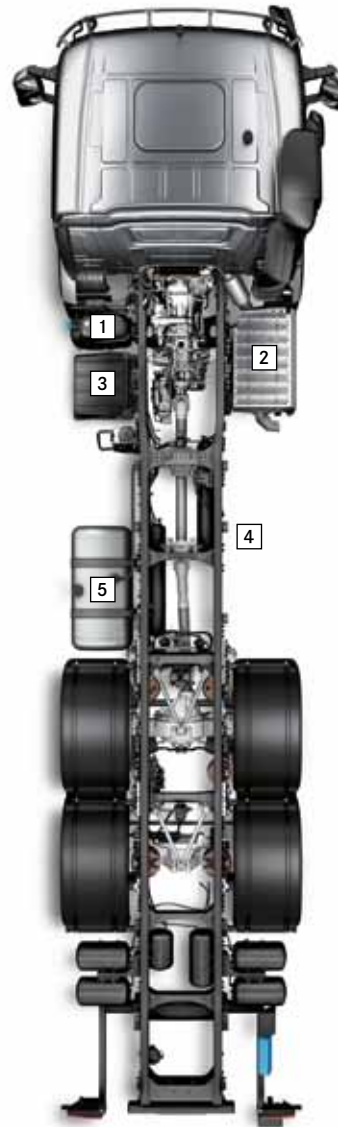

- 1 AdBlue® 60 l
- 2 Exhaust gas aftertreatment system
- 3 Battery
- 4 Installation space e.g. for attachments
- 5 Tank narrow/low 390 l

Example tank variant for Antos tractor unit



- 1 AdBlue® 60 l
- 2 Exhaust gas aftertreatment system
- 3 Space e.g. for second tank
- 4 Tank narrow/high 390 l
- 5 Space e.g. for hydraulic fluid tank

## The Antos – engine performance data

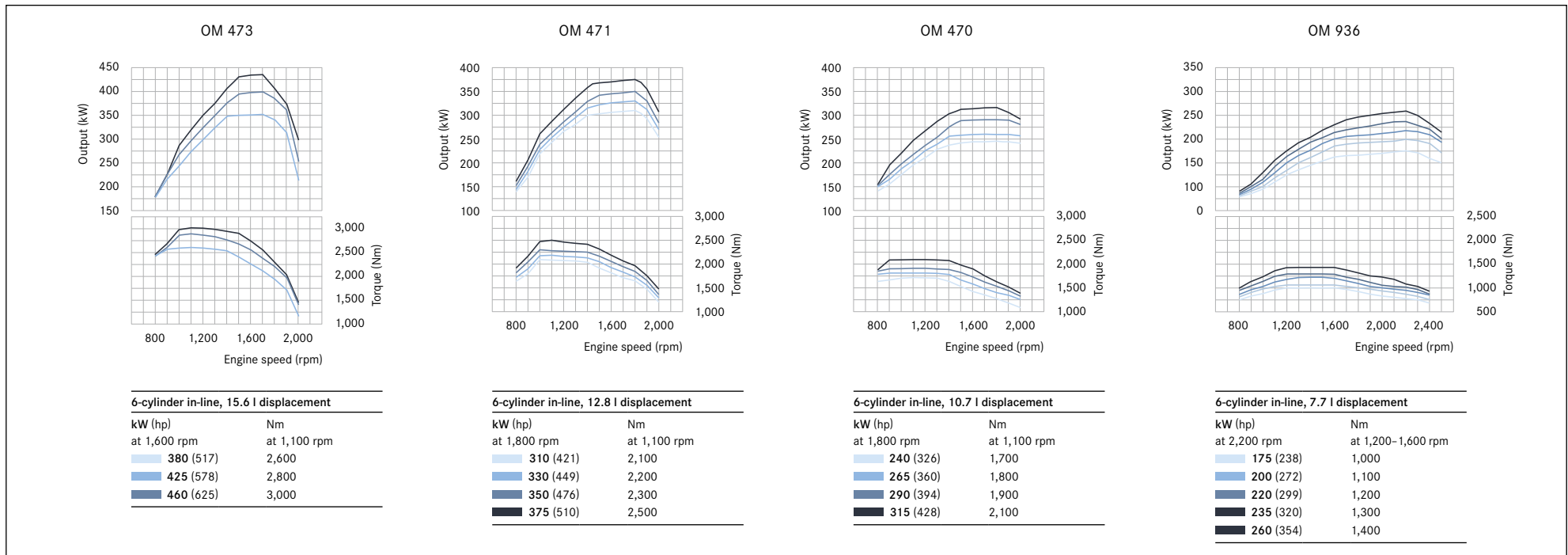

The Antos Euro VI engines: future-oriented technology, up to **460 kW** (625 hp) and a maximum torque of 3,000 Nm.

## The Antos – variability of frame overhangs and end cross members



Frame overhangs can be set at 300 mm increments

50 mm increments for end cross member

Factory-fitted frame overhangs which can be selected in 300 mm increments and the end cross member which can be moved in 50 mm increments (up to a maximum of 150 mm overall) increase ease of body mounting and reduce mounting costs.

Antos rigid - model overview						
Model designation	18xx <sup>5)</sup>	18xx (Volumer)	25xx <sup>2)</sup>	25xx (Volumer)	26xx	26xx
Wheel configuration	4x2	4x2	6x2 ENA	6x2 ENA	6x4	6x2 DNA
Rear axle suspension	Air	Air <sup>1)</sup>	Air	Air <sup>1)</sup>	Air <sup>9)</sup>	Air
<b>Engines</b>						
<b>OM 936</b>						
175 kW (238 hp)	x <sup>3)</sup>	x	x <sup>3)</sup>	-	x	x
200 kW (272 hp)	x <sup>3)</sup>	x	x <sup>3)</sup>	x	x	x
220 kW (299 hp)	x <sup>3)</sup>	x	x <sup>3)</sup>	x	x	x
235 kW (320 hp)	x <sup>3)</sup>	x	x <sup>3)</sup>	x	x	x
260 kW (354 hp)	x <sup>3)</sup>	x	x <sup>3)</sup>	x	x	x
<b>OM 470</b>						
240 kW (326 hp)	x <sup>3)</sup>	x	x <sup>3)</sup>	x	x	x
265 kW (360 hp)	x <sup>3)</sup>	x	x <sup>3)</sup>	x	x	x
290 kW (394 hp)	x <sup>3)</sup>	x	x <sup>3)</sup>	x	x	x
315 kW (428 hp)	x <sup>3)</sup>	x	x <sup>3)</sup>	x	x	x
<b>OM 471</b>						
310 kW (421 hp)	x	x	x	x	x	x
330 kW (449 hp)	x	x	x	x	x	x
350 kW (476 hp)	x	x	x	x	x	x
375 kW (510 hp)	x	-	x	x	x	x
<b>OM 473</b>						
380 kW (517 hp)	x	-	x	-	x	x
425 kW (578 hp)	x	-	x	-	x	x
460 kW (625 hp)	x	-	x	-	x	x
<b>Wheelbase</b>						
3,700 mm	x	-	-	-	x	-
4,000 mm	x	-	x	x	x	x
4,300 mm	x	-	x	x	x	x
4,600 mm	x	-	x	x	x	x
4,900 mm	x	x	x	x	x	x
5,200 mm	x	-	x	x	x	x
5,500 mm	x	x <sup>4)</sup>	x	x	x	x
5,800 mm	x	x <sup>4)</sup>	x	x	x	x
6,100 mm	x	-	x	-	-	x
6,400 mm	x	-	-	-	-	-
6,700 mm	x	x	-	-	-	-
<b>Cab variants</b>						
ClassicSpace S-cab, Tunnel 170 mm	x	x	x	x	x	x
ClassicSpace S-cab, Tunnel 320 mm	x	x	x	x	x	x
ClassicSpace M-cab, Tunnel 170 mm	x	x	x	x	x	x
ClassicSpace M-cab, Tunnel 320 mm	x	x	x	x	x	x
CompactSpace M-cab, Tunnel 170 mm	x	x	x	x	x	x
CompactSpace M-cab, Tunnel 320 mm	x	x	x	x	x	x

x Available    - Not available    <sup>1)</sup> Full air suspension as standard.    <sup>2)</sup> Also available as 6x2/4 mid-steer version, with wheelbases from 3,550 mm to 4,150 mm.    <sup>3)</sup> Also available as Antos Loader model.  
<sup>4)</sup> Also available as Car Transporter model (LnRA).    <sup>5)</sup> Also available as heavy duty version.

Antos tractor units – model overview							
Model designation	18xx <sup>3)</sup>	18xx (Volumer)	24xx	25xx	25xx	26xx <sup>3)</sup>	26xx
Wheel configuration	4x2	4x2	6x2/2	6x2 ENA	6x2/2 <sup>2)</sup>	6x4	6x2 DNA
Rear axle suspension	Air	Air	Air	Air	Air	Air	Air
<b>Engines</b>							
<b>OM 936</b>							
175 kW (238 hp)	x	x	x	x	x	x	x
200 kW (272 hp)	x	x	x	x	x	x	x
220 kW (299 hp)	x	x	x	x	x	x	x
235 kW (320 hp)	x <sup>1)</sup>	x	x <sup>1)</sup>	x	x <sup>1)</sup>	x	x
260 kW (354 hp)	x <sup>1)</sup>	x	x <sup>1)</sup>	x	x <sup>1)</sup>	x	x
<b>OM 470</b>							
240 kW (326 hp)	x <sup>1)</sup>	x	x <sup>1)</sup>	x	x <sup>1)</sup>	x	x
265 kW (360 hp)	x <sup>1)</sup>	x	x <sup>1)</sup>	x	x <sup>1)</sup>	x	x
290 kW (394 hp)	x <sup>1)</sup>	x	x <sup>1)</sup>	x	x <sup>1)</sup>	x	x
315 kW (428 hp)	x <sup>1)</sup>	x	x <sup>1)</sup>	x	x <sup>1)</sup>	x	x
<b>OM 471</b>							
310 kW (421 hp)	x	x	x	x	x	x	x
330 kW (449 hp)	x	x	x	x	x	x	x
350 kW (476 hp)	x	x	x	x	x	x	x
375 kW (510 hp)	x	-	x	x	x	x	x
<b>OM 473</b>							
380 kW (517 hp)	x	-	x	x	x	x	x
425 kW (578 hp)	x	-	x	x	x	x	x
460 kW (625 hp)	x	-	x	x	x	x	x
<b>Wheelbase</b>							
2,650 mm	-	-	-	-	x	-	-
2,990 mm	-	-	x	-	-	-	-
3,250 mm	-	-	-	x	-	x	x
3,400 mm	-	-	-	x	-	x	x
3,550 mm	x	-	-	x	-	x	x
3,700 mm	x	x	-	-	-	-	-
3,850 mm	x	-	-	-	-	-	-
4,000 mm	x	-	-	-	-	x	-
<b>Cab variants</b>							
ClassicSpace S-cab, Tunnel 170 mm	x	x	x	x	x	x	x
ClassicSpace S-cab, Tunnel 320 mm	x	x	x	x	x	x	x
ClassicSpace M-cab, Tunnel 170 mm	x	x	x	x	x	x	x
ClassicSpace M-cab, Tunnel 320 mm	x	x	x	x	x	x	x
CompactSpace M-cab, Tunnel 170 mm	x	x	x	x	x	x	x
CompactSpace M-cab, Tunnel 320 mm	x	-	x	x	x	x	x

x Available    - Not available

<sup>1)</sup> Also available as Antos Loader model.

<sup>2)</sup> Also available as 6x2/4 mid-steer version.

<sup>3)</sup> Also available as heavy duty version.

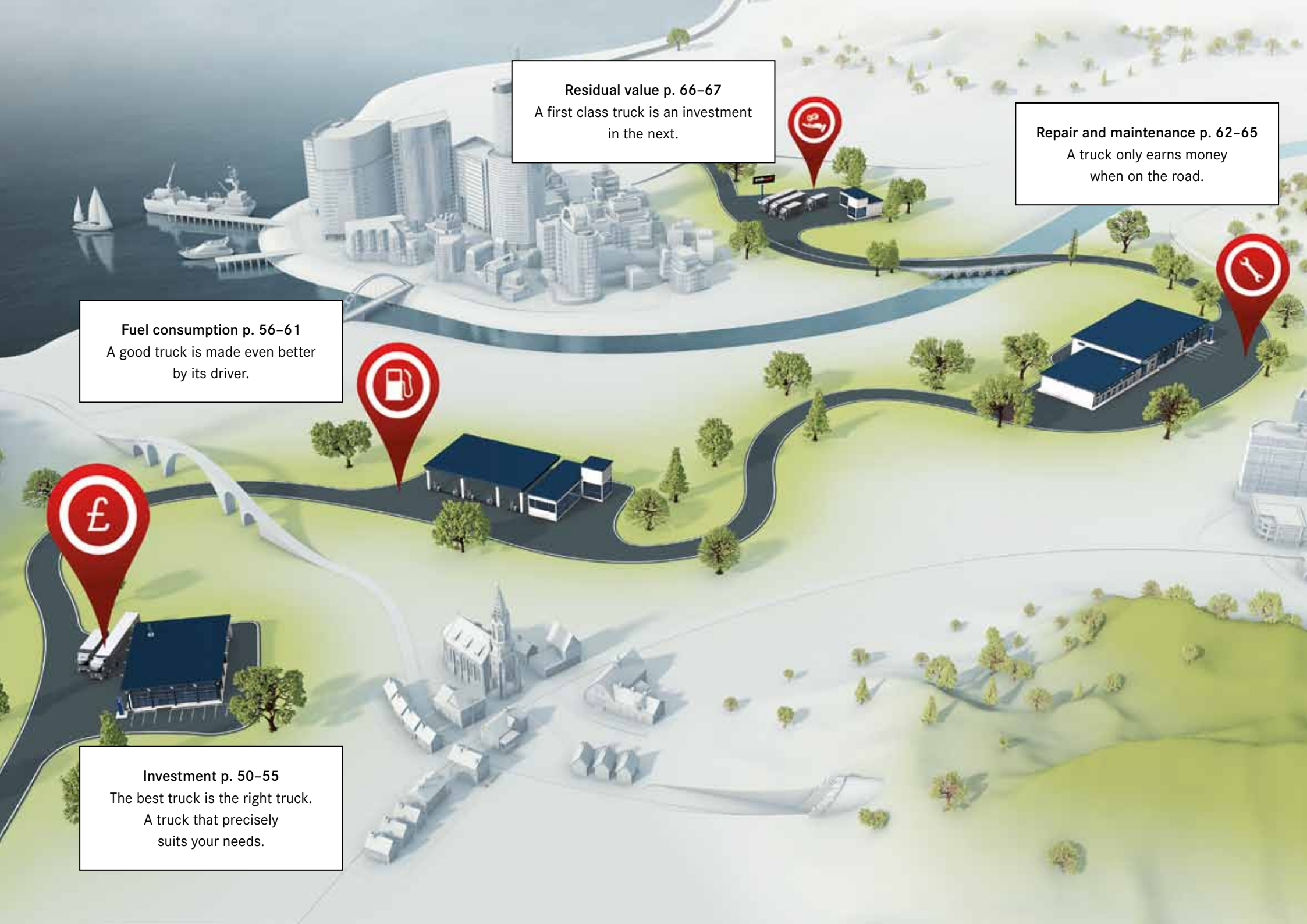

An aerial 3D rendering of a city and its surroundings. A winding road leads from a city center with modern buildings and a harbor with ships, through a green landscape with trees, to a large industrial or warehouse building. Several red location pins with white icons are placed along the road: a pound sign (£), a fuel pump, a truck, and a wrench. Five white text boxes with black borders are overlaid on the scene, each containing text related to truck ownership and operation.

**Residual value p. 66–67**  
A first class truck is an investment  
in the next.

**Repair and maintenance p. 62–65**  
A truck only earns money  
when on the road.

**Fuel consumption p. 56–61**  
A good truck is made even better  
by its driver.

**Investment p. 50–55**  
The best truck is the right truck.  
A truck that precisely  
suits your needs.

# An overall solution for greater economy.

More profitable transport: we offer not only economical, future-oriented vehicle engineering and technology, but also services tailored precisely to your needs. For more efficiency. From day one.

## An all-round solution for greater economic efficiency.

The overall economy of a truck is determined by many factors. While it is not possible to influence all costs – such as insurance and tax – there is plenty that can be done to make a truck more economical. Mercedes-Benz helps to achieve an additional significant increase in the profitability of long distance and distribution transport by reducing key cost factors, such as fuel consumption – as well as repair and maintenance. The basis is provided by innovative vehicle technology and services tailored perfectly to individual needs, which enable even more effective exploitation of the vast potential for boosting profitability which is offered by the Mercedes-Benz truck range. Find out on the following pages what we can do for you in the areas of investment, fuel consumption, maintenance, repair and residual value to minimise these costs. To make your transport operations more economical overall.

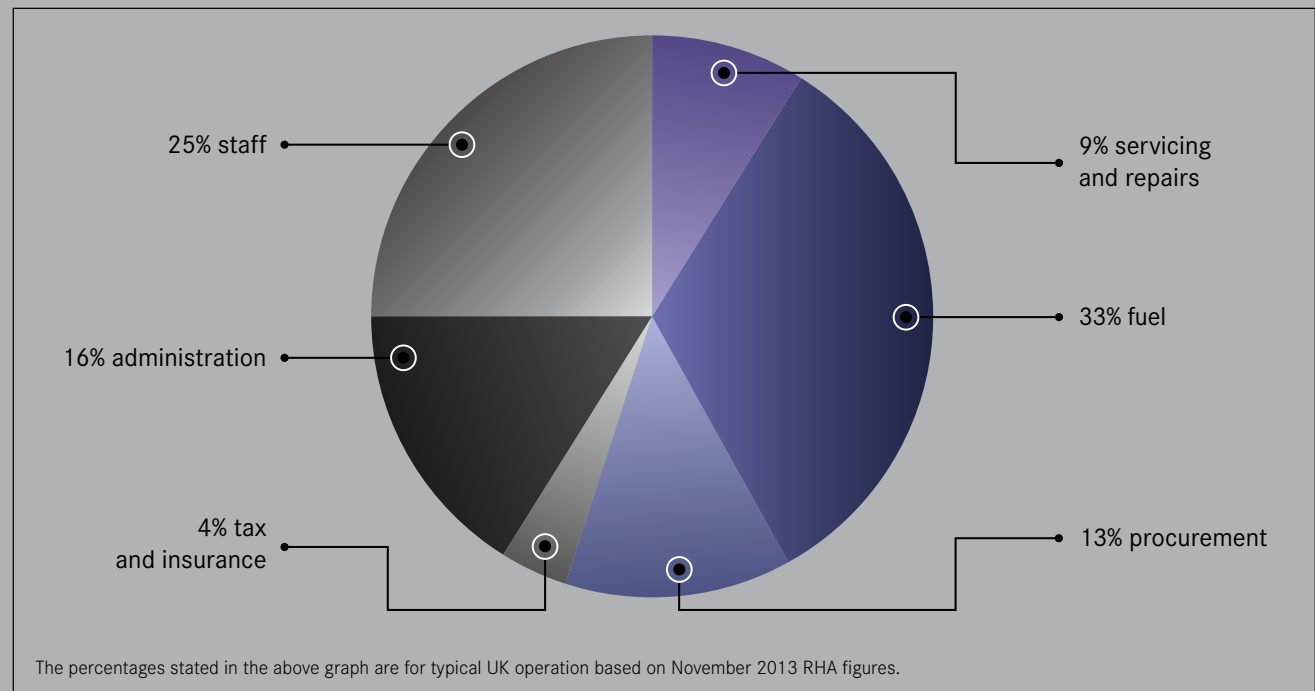

**Cost structure.** For truck operation we make a distinction between vehicle-related costs such as procurement, fuel consumption, maintenance and repair and operating costs such as tax and insurance. In addition, staff and administration costs are incurred. We are able to influence most of these cost types. On the following pages we will focus on the vehicle-related costs which we as a manufacturer are best able to influence.

# The best investment: a truck that produces savings, rather than costs.



Greater cost-effectiveness right from the start and during the entire period of use. Through vehicles with innovative technology and services which pay right from day one. Because they are precisely tailored to your distribution transportation requirements. After all, the right investment is the best investment. An investment which suits you perfectly.

**Distribution vehicles.** A good investment must meet all your requirements. Like the Atego and the Antos in the light and heavy distribution sectors respectively. With their innovative vehicle technology and excellent body-mounting ability, they are ideally placed to enable you to operate particularly cost-effectively. The line-up of economical Euro VI engines ranges from **115 kW** (156 hp) to **220 kW** (299 hp) for the Atego and from **175 kW** (238 hp) to **460 kW** (625 hp) for the Antos. The potential of these engines is maximised by the precisely tuned powertrain configurations as well as the sophisticated aerodynamics. For applications where a high payload or large load capacity are the decisive factors we have developed the Antos Loader and Antos Volumer. See pages 38–41 for more information.





**Application Information Centre (BIC).** The Application Information Centre in Würth offers a permanent display of around 180 industry-specific complete vehicles with body solutions from over 70 manufacturers. All the vehicles and body solutions can be test-driven, demonstrated, tried out and directly compared with each other in real-life conditions so that the optimal transport solution can be found quickly and easily. We also offer sector-specific events with driving experiences.

**Mercedes-Benz Custom Tailored Trucks.** Made-to-measure trucks. Mercedes-Benz Custom Tailored Trucks (CTT) extends our wide portfolio and meets your special requirements with products which embody proven Mercedes-Benz quality: From the detailed consultation stage and definition of the conversion specification, through the design engineering, simulation and testing phases all the way to delivery, we are your single point of contact for the entire project. Supported by selected partners, CTT is able to meet individual customer requirements – for complex axle and chassis modifications for special bodies or the repositioning of components, for example. In short, Mercedes-Benz Custom Tailored Trucks provides the precise solution you need for your application.



**Investment (1) – advantages at a glance.**

- Application-matched vehicles for light and heavy distribution work
- Comprehensive Euro VI engine range: Atego: seven power variants from 115 kW (156 hp) to 220 kW (299 hp)  
Antos: 16 power variants from 175 kW (238 hp) to 460 kW (625 hp)
- Sector-specific vehicle concepts – Antos Loader and Antos Volumer
- Application Information Centre in Würth with approx. 180 practical, sector-specific solutions providing hands-on access, to test, compare and test drive. Sector-specific events with driving experiences
- Mercedes-Benz Custom Tailored Trucks for tailored body building





# FleetBoard: Greater efficiency through enhanced transparency.



FleetBoard stands for telematics-based vehicle, driver and transport management which contributes to greater cost-effectiveness. At the same time, FleetBoard forms the basis of a large number of services which increase efficiency and therefore ensures that you are able to operate even more efficiently and cost-effectively.

**FleetBoard.** These are telematics-based internet services which are central to leading-edge vehicle, fleet and transport management and which can enhance the cost-effectiveness of your fleet in various ways. They are based on the FleetBoard TiiRec vehicle computer which is available ex factory.

**FleetBoard Transport Management.** FleetBoard Transport Management stands for greater efficiency in logistics processes and can be integrated flexibly into a company's own systems. The DispoPilot.guide supports efficient communications, transparent processes and the easy exchange of information between driver and headquarters. With the new DispoPilot.app<sup>1</sup>, it is now possible for subcontractors to be integrated quickly and easily in transport processes.



**Greater efficiency.** FleetBoard Transport Management offers efficient communication with the driver. All order and route details are sent directly to the DispoPilot.mobile to avoid circuitous routes and misunderstandings. Other advantages include the integrated barcode scanner which allows the driver to perform a target/actual comparison of packages when delivering goods. The customer's digital signature can also be recorded on the DispoPilot.mobile screen and transferred directly to dispatch.

**FleetBoard Time Management.** FleetBoard Time Management ensures that you can always keep track of your drivers' driving time and rest periods – an ideal basis for optimal resource and trip planning. Furthermore, you comply with all the statutory regulations regarding the archiving of driving times and rest periods – in fact, this practically takes care of itself. This saves money and reduces administrative effort.

**FleetBoard App.** With the FleetBoard app for iPhone®, iPad® and Android devices, you are kept informed about whether journeys are running according to schedule wherever you are, any time of day or night.

**More information.** Details of further advantages of FleetBoard are also available at [www.fleetboard.com](http://www.fleetboard.com) or direct from your authorised Mercedes-Benz Dealer.



**FleetBoard TiiRec.** The FleetBoard TiiRec vehicle computer forms the basis for using the FleetBoard services and the various Mercedes-Benz services to increase efficiency.



**DispoPilot.guide.** The quick and easy way to your destination: once the job data have been transmitted, information such as the delivery or pick-up address can be transferred directly to the integrated navigation system.

**i** Investment (2) – advantages at a glance.

- FleetBoard – telematics for greater cost-effectiveness
- FleetBoard Logistics Management for efficient logistics processes
- FleetBoard Time Management for optimal resource and trip planning as well as easy compliance with statutory regulations and reduction of the documentation workload
- FleetBoard app for mobile access to the fleet

<sup>1)</sup> Expected to be available from 4/2015.



# Invest in powerful support services that give you a competitive edge.



Buy? Lease? Or start by renting for now? Whichever method you decide on, your finance provider Mercedes-Benz Finance is able to offer the appropriate comprehensive solution to meet your needs for vehicle procurement with mobility assurance and a reduced administrative workload. And, through Mercedes-Benz Finance, attractive leasing and financing products matched to the profile of your business.

**Mercedes-Benz Finance solutions.** Geared to attractive overall costs, Mercedes-Benz Finance offers efficient and economical transport solutions when they are needed most: in risk protection, in ensuring the best possible vehicle availability and in transparent cost calculation.

**Mercedes-Benz Finance products.** The most widely-used finance arrangement for Commercial Vehicles is Contract Hire and there are many other options available to suit your requirements. If you're considering ownership, you can select Hire Purchase or our Agility scheme. Or perhaps a lease would be more suitable. We can also provide Service Contracts which are designed to help you keep your vehicles running with maximum cost-efficiency.



**Mercedes-Benz Finance.** Contract Hire can be seen as a combination of an operating lease, plus repair and maintenance agreement, all arranged into one simple monthly payment. The products have been designed to offer optimum cover for the requirements of every fleet. How you benefit: costs can be planned, risks reduced to a minimum and optimal vehicle availability can be ensured. Consult your authorised Mercedes-Benz Dealer for more information.

**Mercedes-Benz Finance.** With Mercedes-Benz Finance, you can count on an expert and dedicated partner with attractive finance and leasing products.

**Flexible financial products.** Matched to the specific requirements of your business: Available from Mercedes-Benz Finance, Agility for example, works where you are given a Guaranteed Future Value which is equal to the Optional Purchase Payment – but you don't have to decide whether to make this payment and keep the vehicle until the end of the agreement. In the meantime, you simply choose

how long you want to keep the vehicle, how much you'd like to pay as an initial deposit and the monthly payments that suit you best. When the agreement comes to an end you can either purchase, return or part-exchange the vehicle.



Everything from a single source – as a specialist in financing and leasing, Mercedes-Benz Finance offers you individual solutions for vehicle procurement that are optimally tailored to your company's needs – with especially interesting terms and conditions.



#### Investment (3) – advantages at a glance.

- Mercedes-Benz Finance for vehicle procurement, transport assurance and a reduced administrative workload
- Rental offers for high flexibility without any capital tie-up
- Mercedes-Benz Finance service products
- All can be coupled with leasing agreement to create individual service leasing products
- Easy control of planning/costs through instalments precisely determined beforehand
- Mercedes-Benz Finance for individual leasing and financing products





# Our tip for low fuel consumption costs: Top technology, top services and a top driving style.



In the Antos and Atego you have vehicles which use fuel extremely efficiently. What's more: through the combination of vehicle technology and services, such as our driver training, further significant reductions in fuel costs are possible. An accomplished driver can make a good truck even better.

**Engines with reduced fuel consumption.** For particularly efficient distribution transport operations, the 4 and 6-cylinder in-line engines used in the Atego achieve fuel savings of up to 5%<sup>1)</sup> compared with the predecessor model. In the Antos, the X-Pulse common-rail high-pressure injection system is one of the factors which helps to operate particularly efficiently. AdBlue<sup>®</sup> injection without compressed air and the cooled exhaust gas recirculation help to make further fuel savings. A further advantage of the system: AdBlue<sup>®</sup> consumption is reduced by up to 40%. The bottom line here is: these vehicles are ideally placed to enable you to operate particularly economically in the distribution sector. And lower fuel consumption also means considerably lower CO<sub>2</sub> emissions as well as reduced particulate and nitrogen oxide emissions.

Additional auxiliary braking – up to **475 kW** depending on engine – is also available for even greater safety, and helps to encourage a fuel-efficient driving style.

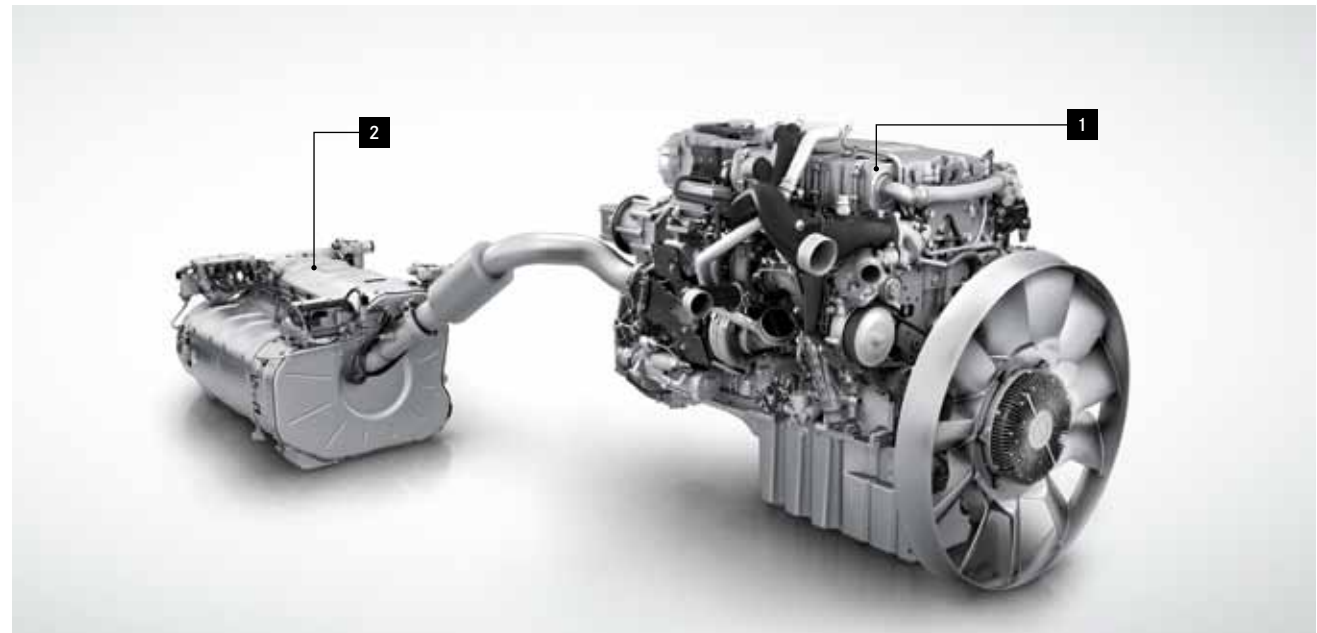

**Antos Euro VI emissions technology.** 1. Reduced nitrogen oxide production during fuel combustion thanks to cooled exhaust-gas recirculation 2. The Euro VI engines' exhaust system is fitted with a highly effective diesel particulate filter. The AdBlue<sup>®</sup> is injected into the exhaust gas flow without air through the optimised metering unit. The nitrogen oxides are completely converted into water and nitrogen in the SCR catalytic converter.

**Axles, transmissions, ancillaries.** A wide choice of rear axle ratios and transmissions matched to various operating profiles also plays a role in keeping fuel consumption low. What's more, short shift times and the "economy" or "fleet"<sup>2)</sup> driving programs also support an economical driving style. Economical ancillary consumers, such as the on-demand compressed-air control system and the power steering pump also contribute to low fuel consumption.

**Low drag and rolling resistance.** The design of the Atego and Antos has been optimised right down to the smallest detail in order to reduce wind resistance. From the bumper through the corner panels to the roof – everything contributes to reduced drag and so to lower fuel consumption.

Aerodynamic detachable body parts also play a role in cutting consumption. Along with the tyre pressure monitoring system, super-wide single tyres<sup>3)</sup> are available on the drive axle to reduce rolling resistance and fuel consumption, too.

<sup>1)</sup> Fuel savings are slightly lower in urban traffic than for inter-urban or motorway driving.

<sup>2)</sup> Only for Antos.

<sup>3)</sup> Single tyres not suitable for maximum-weight operation on 3-axle vehicles.



**Two-stage air compressor.** This contributes to the truck's low fuel consumption. Low weight and high reliability are additional benefits.



**Sophisticated aerodynamics.** When designing the Antos, we tested every individual part extensively. In the wind tunnel and over many millions of test kilometres – for extremely low wind resistance and low fuel consumption.



**Tyre pressure monitoring system<sup>2)</sup>.** The wireless pressure monitoring system for the front and rear axles continuously monitors the air pressure in all the tyres of the tractor unit as well as those of the semitrailer or trailer.

**FleetBoard Driving Analysis.** The FleetBoard driving analysis contributes to a driving style which reduces fuel consumption and wear. To this end, the telematics system records and analyses technical data from the truck. Furthermore, FleetBoard driving analysis now also shows how intensively Predictive Powertrain Control is being used. The driver's style of driving is assessed on the basis of these data and a corresponding mark is awarded. This enables an objective assessment of the driving style and allows the training to be tailored to the individual driver. What's more, the combination of FleetBoard driving analysis and FleetBoard EcoSupport also ensures that the fuel-saving driving style which the driver is taught during Mercedes-Benz EcoTraining is maintained over the long term. Overall, long-term fuel savings of up to 15% can be achieved in this way.

**FleetBoard EcoSupport.** The system assists the driver in a fuel-saving driving style. To this end it displays tips while on the road that provide an opportunity to further optimise the individual driving style and reduce fuel consumption.

**EcoTraining.** Mercedes-Benz EcoTraining teaches a way of driving that allows you to make even better use of the technical potential of your truck. This can lead to fuel savings of up to 10%.

This is based on the evaluation of the data from the FleetBoard driving analysis.



**FleetBoard Driver's League.** A contest where drivers can demonstrate their skills. Where saving fuel is fun and is rewarded twice over. Your drivers can win attractive prizes and you reduce your costs. For more information and to register, go to [www.driversleague.com](http://www.driversleague.com)



- i** Low fuel consumption costs – advantages at a glance.
- Low consumption as a result of: economical, efficient engines, short shift times and the “economy” and “fleet” driving programs designed to reduce fuel consumption
  - Application-matched rear-axle ratios and transmissions
  - Ancillary consumers with reduced fuel consumption
  - Sophisticated aerodynamics
  - Low rolling resistance through super-wide tyres and tyre pressure monitoring system
  - Plus: fuel saving of up to 15% through FleetBoard driving analysis, FleetBoard EcoSupport and Mercedes-Benz EcoTraining
  - FleetBoard Driver's-League as an additional motivator for fuel-saving driving





# Predictive Powertrain Control: it knows your route. From start to finish. And provides for additional diesel savings of up to 5%.



Predictive Powertrain Control allows you to operate even more economically. Because the system always knows the route ahead. As a result, it can achieve fuel savings of up to 5% on motorways and highways covered by PPC in Western and Eastern Europe.

**Predictive Powertrain Control.** Optionally available for Antos, the system integrates an additional mode into the automatic transmission system that adapts to the topography of the road ahead and so enables fuel savings of up to 5%. Using satellite-based positioning technology and maps, Predictive Powertrain Control (PPC) identifies the course of the road and any downhill and uphill stretches ahead. The data provide the basis for the optimisation of the shift points, gear steps and the set cruise control speed. The kinetic energy of the vehicle is used as far as possible to avoid unnecessary acceleration, shifting or braking. PPC knows over 295,000 kilometres (95%) of the European trunk road network and can be used at speeds between 25 and 85 km/h.



**Topography-oriented driving style.** Predictive Powertrain Control uses digital 3D road maps and GPS information to generate an electronic horizon which is employed to optimise shift points, gear selection and the set cruise control speed in anticipatory mode. In this way, a driving style adapted to the given topography which will generally be beyond the capabilities even of experienced drivers can be integrated into the automated system, resulting in additional fuel savings of up to 5%.

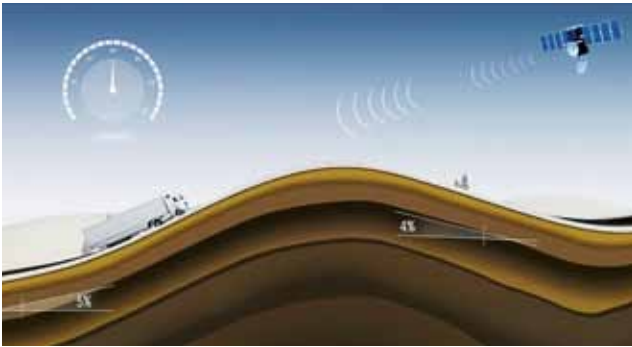

**Driving situation: steep uphill gradient.** In order to avoid shifting on an incline as far as possible, PPC performs the shift – in so far as it is useful – before the start of the climb and/or increases the speed within the upper limit of the hysteresis range. Predictive Powertrain Control additionally provides for an optimised shift sequence, e.g. fewer gear changes and larger gear steps.

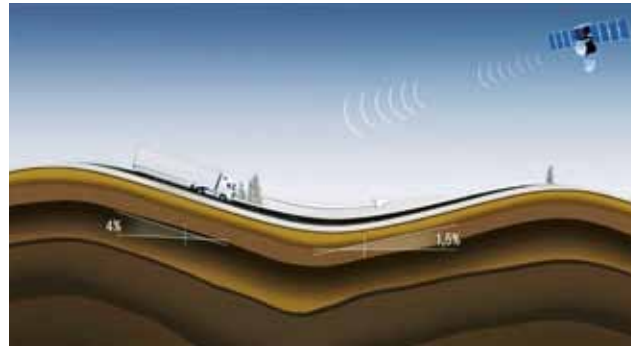

**Driving situation: coasting.** Why accelerate when coasting is sufficient? The kinetic energy of the vehicle is continuously determined. In other words: the vehicle automatically detects if it can attain the set cruise control speed quickly enough by coasting. What's more, EcoRoll can be used to avoid engine drag losses.

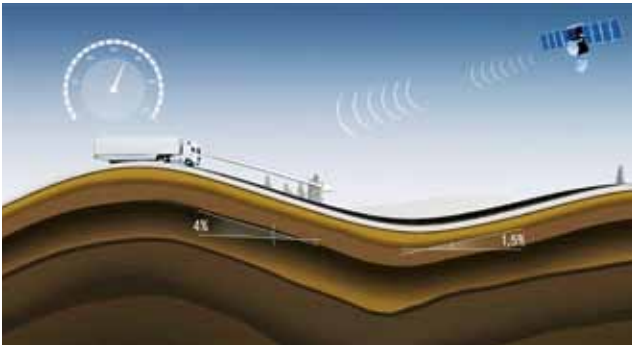

**Driving situation: brow of a hill.** The principle centres on coasting over the brows of hills to avoid braking on downhill stretches. The kinetic energy of the vehicle is continuously determined. This enables the vehicle to assess in good time whether it can coast over the brow of the hill at adequate speed. EcoRoll can be used to reduce engine drag losses.

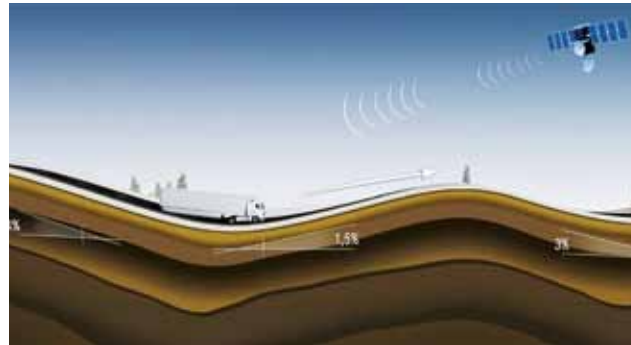

**Driving situation: EcoRoll.** As a result of precise activation, Predictive Powertrain Control is able to make optimum use of EcoRoll phases. This means that, in addition to saving fuel on virtually level stretches, EcoRoll is also activated ahead of the brows of hills and at the end of hill sections below the set speed. This results in markedly longer EcoRoll phases.

**i Predictive Powertrain Control – advantages at a glance.**

- Predictive Powertrain Control: Up to 5% less fuel consumption resulting from driving style adapted to the given topography
- Identification of the course of the road with downhill and uphill sections
- Optimisation of shift points, gear selection and the cruise-control speed setting
- Optimum use of the system via traffic-dependent setting with adjustable upper and lower hysteresis
- Available across Europe on motorways and trunk roads with PPC coverage



# Lower costs, higher efficiency. Also for service.



A truck only earns money when it is on the move. This is why we do all we can to ensure that repair and maintenance costs are kept as low as possible and to increase vehicle availability. For example, with excellent workshop service, Service Contracts and Mercedes-Benz Service24h.

**High cost-effectiveness.** From the very start, the Atego and the Antos were designed with a view to keeping costs particularly low – both in everyday use and with regard to maintenance and repairs. Furthermore, additional cost savings are possible with Service Contracts, for example.

**Ease of repair.** The introduction of the new Euro VI emissions standard brought with it considerable additional technical sophistication. There are many reasons why our trucks can nevertheless be repaired and maintained as inexpensively as comparable predecessor models. Right back at the design stage, care was taken to ensure that all the components are not only particularly robust but can also be replaced or repaired particularly quickly and cost-effectively if necessary. For lower costs and higher efficiency.

**Mercedes-Benz Service.** Throughout Europe some 1,800 Mercedes-Benz service outlets are at your disposal for workshop services, many of which are open late, or even through the night. Furthermore, our trained staff and an extremely efficient parts logistics system enable particularly short

repair times and ensure that your truck is back on the road as quickly as possible.

**Mercedes-Benz Genuine Remanufactured Parts.** As a cost-effective and environmentally friendly alternative, the extensive portfolio of remanufactured parts offers high quality and tested safety. In addition, remanufactured parts are 35% cheaper on average – with the same warranty as a new part.

**Fixed price packages.** With our fixed-price packages, you know in advance what costs will be incurred and how long the maintenance or repair will take. As a result, you can plan with certainty with regard to costs and vehicle availability.



**Mercedes-Benz GenuineParts.** High quality at an affordable price as a basis for value retention and overall economy. The extensive range of parts, efficient logistics and quick availability are further advantages.

**Service Contracts.** Graduated service contracts offer tailor made solutions for predictable monthly service costs and a fleet running to maximum available capacity. Despite the higher complexity resulting from compliance with Euro VI, the Complete full-service contract remains available for the same price as applies to Euro V vehicles.

Service contracts ensure that throughout its life your truck is maintained to the highest standards, by qualified technicians, using Mercedes-Benz GenuineParts. So not only are you managing your finances and avoiding unexpected bills, your truck is kept running at its optimum performance for much less.



**Extended opening hours.** There are about 1,800 Mercedes-Benz service outlets throughout Europe and of these some 300 are open until 10 pm with an increasing number even staying open until midnight. This makes maintenance planning easier and more flexible. What's more: even more major repairs can be carried out within one working day – so that your truck is not at the workshop any longer than absolutely necessary.



**Mercedes-Benz Finance.** Tailor-made mobility solutions which can be combined in accordance with individual requirements and which ensure that you know in advance exactly how much a given vehicle will cost you.



**Service24h.** Keeping your business running 24 hours a day. To deal with any unforeseen incident, the UK network maintains over 150 fully equipped service vans, totally dedicated to providing Service24h roadside assistance. Work will be undertaken by accredited Mercedes-Benz technicians, who have the skills, knowledge and experience to keep your vehicles moving. Throughout the UK and Europe, you can count on us at any time. Our technicians will be with you as quickly as possible. With the right expertise and Mercedes-Benz GenuineParts you will soon be on your way again.

**Tyre pressure monitoring.** With FleetBoard “Service” you can ensure that your vehicle is kept in optimum operating condition. For example, the new tyre pressure monitoring system makes it possible to ensure that your truck’s tyres are inflated correctly. This helps to keep down fuel consumption and tyre wear and to prevent unscheduled downtime because of flat tyres.



**Service24h 00800 5777 7777.** If your mobile phone provider charges for Freephone numbers, please call +44 (0)333 220 6608. A call to the free Europe-wide service hotline is all it takes to receive rapid assistance in case of breakdown. Service24h will then immediately ensure that you can continue your journey – and it is on hand 365 days a year, 7 days a week and 24 hours a day.



**i** Service – advantages at a glance.

- Service-oriented design for lower repair and maintenance costs
- Extensive workshop network with around 1,800 service outlets throughout Europe
- Long workshop opening hours, in many instances until 10 p.m. or midnight
- Mercedes-Benz GenuineParts for high reliability and value retention as well as Genuine Remanufactured Parts as a cost-effective alternative
- Fixed-price packages for highest degree of budgeting certainty
- Service Contracts enable monthly instalment planning as well as increased vehicle availability
- Service24hfast emergency assistance is available around the clock via the free service hotline on 00800 5777 7777

# The higher the residual value, the lower the investment for the next vehicle.



When you choose one of our trucks, you can count on being able to operate particularly economically throughout its entire period of use. At the same time, the expected high residual value lays the foundations for the future. Because a first-rate truck is an investment in the next truck.

**Residual value.** As a result of their innovative vehicle technology and the application matched vehicle configurations, the Mercedes-Benz truck range offers the prospect of a particularly high residual value, whatever the sector. This is an important consideration for every truck operator, as the higher the residual value at the end of its period of service, the lower the acquisition costs for a new truck will be.

**Used Commercial Vehicles.** We have the largest selection of Mercedes-Benz Used Commercial Vehicles in the UK, available from 60 Dealer locations and supported by over 90 Dealer service departments. Only our premium quality trucks qualify to be one of our Approved Trucks.





With used trucks ranging from six months up to 10 years old available to us, and with additional services such as Finance, Repair & Maintenance and Mechanical Breakdown Insurance, we think we can supply the used commercial vehicle you're looking for.

A used vehicle locator is available to help you search for your truck – [www.usedtrucks.mercedes-benz.co.uk](http://www.usedtrucks.mercedes-benz.co.uk)

**Finance with Mercedes-Benz.** At Mercedes-Benz we are able to offer you sound financial advice about the options open to you when buying one of our used trucks.

Our in-house finance department offers financial packages such as Contract Hire, Finance Lease, Operating Lease and Hire Purchase with or without a balloon payment. We are able to offer you a no obligation and confidential quotation to meet your own requirements, and at highly competitive rates.

**Peace of mind with Mercedes-Benz Repair & Maintenance.**

For peace of mind over your running costs, why not take out one of our Repair & Maintenance Contracts, which are available on our full range of used trucks and include 24hr Service and Aftersales Support from over 90 UK Dealer locations.

**Mechanical Breakdown Insurance.** Benefit from an impressive range of products and services and first-class advice: with the finance packages offered by Approved Used Commercial Vehicles we think we can supply the used commercial vehicle you're looking for. Choose between classic financing and leasing arrangements or numerous individual variants and so reduce your capital commitment.



**i** Advantages at a glance.

- The Mercedes-Benz truck range offers particularly high residual values, whatever the sector
- The largest selection of Mercedes-Benz Used Commercial Vehicles in the UK
- Only our premium quality trucks qualify to be one of our Approved Trucks





# You can never have too many guardian angels.

Assistance and safety systems offer the best possible safety on every journey by actively reducing the strain on the driver. They do this by helping the driver to overcome the demands of driving in ever heavier traffic while staying relaxed and poised.

**Safety equipment.** Mercedes-Benz employs many safety and assistance systems to reduce risks and ease the burden on the driver.

Along with the Electronic Braking System with ABS, ASR, Brake Assist and hill holder, Stability Control Assist and a driver airbag also contribute to the high level of safety. Systems such as the rain/light sensor, the co-driver mirror with manoeuvring function<sup>1)</sup>, Lane Keeping Assist<sup>1)</sup>, Roll Control Assist<sup>1)</sup> and the tyre pressure monitoring system<sup>1)</sup> provide additional support for the driver.

**Secondary water retarder.** Wear-free and maintenance-free, the secondary water retarder<sup>1)</sup> offers greater braking power, higher average downhill speeds and lower weight than conventional oil retarders.

**Bi-Xenon headlamps<sup>1)</sup>.** Both the dipped and main beam headlights benefit from the particularly high light output of the bi-xenon lamps which also use less energy than the standard headlights.

**Daytime running lamps.** The additional lighting element contributes to the vehicle's passive safety. What's more, it increases the operating convenience for the driver, as it is impossible to forget to switch on.

**Sensor-controlled fifth-wheel coupling.** The sensor-controlled fifth-wheel coupling<sup>1)</sup> notifies the driver via a display in the instrument cluster whether the fifth-wheel coupling is open or closed. This increases safety and saves on repair costs.

**Safety Packs.** Driver and Safety Packs<sup>1)</sup> increase comfort and safety. Additional discounts for these sought-after packages offer even greater cost-effectiveness.



**Active Brake Assist 3<sup>1)</sup>.** The safety system can recognise stationary obstacles and, by initiating a full brake application in time, can mitigate the consequences of rear-end collisions or even avoid them entirely.



**Tyre pressure monitoring system<sup>1)</sup>.** The wireless pressure monitoring system for the front and rear axles continuously monitors the air pressure in all the tyres of the tractor unit as well as those of the semitrailer or trailer.



**Attention Assist<sup>2)</sup>.** The system can recognise increasing tiredness and recommend the driver takes a break.



**Proximity Control Assist<sup>1)</sup>.** The safety system with stop-and-go function is on hand to support the driver in stressful situations and reduces the risk of rear-end collisions. When approaching an identified vehicle driving ahead, the system reduces the speed and maintains the preset distance.



**Safety – advantages at a glance.**

**Braking safety:**

- Electronic brake system with ABS, ASR, Brake Assist and hill holder
- **Secondary water retarder<sup>1)</sup> with up to 3,500 Nm of braking torque**

**Driving safety:**

- Stability Control Assist
- Active Brake Assist 3<sup>1)</sup>
- Proximity Control Assist<sup>1)</sup> with stop-and-go function
- Attention Assist<sup>2)</sup>
- Lane Keeping Assist<sup>1)</sup>
- Roll Control Assist<sup>1)</sup>
- Tyre pressure monitoring system<sup>1)</sup>

**Lighting and visibility:**

- Bi-xenon headlamps<sup>1)</sup>, front fog lamps, LED daytime running lamps and LED tail lights
- Follow-me-home lighting
- Rain/light sensor

**Additional safety features:**

- Sensed fifth-wheel coupling<sup>1)</sup>
- Safety Packs<sup>1)</sup>

<sup>1)</sup> Only for Antos.

<sup>2)</sup> Only available in conjunction with Lane Keeping Assist.



# Genuine Accessories meeting the highest standards.

With the Atego and the Antos, you are ideally prepared for operations in the distribution haulage sector. And so that both are even better placed to reflect your idea of the perfect distribution truck, a comprehensive range of Mercedes-Benz Genuine Accessories is available to meet countless individual design requirements.

**Chrome-finish mirror covers.** The two-part set for the driver's and co-driver's side adds another highlight which gives your vehicle an even more charismatic and attractive appearance.

**Universal mobile phone charging cradle.** The universal mobile phone charging cradle allows you to conveniently operate your mobile phone using the buttons on the multi-function steering wheel. The charging cradle also holds your phone firmly in place while you are driving, recharges the battery and allows it to link up to the vehicle's exterior aerial.



**Eye-catcher.** The surround of the Mercedes-Benz logo below the windscreen underlines the individual character of your truck - while the Mercedes-Benz entrance emblem is another eye-catching feature that adds a special dimension to the experience of climbing aboard.

**Everything always in view.** Activated automatically when reverse is selected, the reversing camera system provides a view of the area immediately behind the vehicle, thus making for enhanced safety and facilitating accident prevention when manoeuvring.



**Protection and comfort.** The seat covers protect the seats against wear, damage and dirt. Besides their straightforward fitting and non-slip design, they make the seat feel pleasant to sit in too.



**Velour and ribbed floor mats.** The rugged floor mats protect the interior from dirt and damage, fit the shape of the footwell optimally and are coated on the underside to prevent them from slipping out of place.



**Wheel nut caps.** Because every detail counts: The stainless steel wheel nut cap protects the rim and the wheel nuts from damage and helps give the truck an individual look.



**Distinctive detail.** The high-gloss polished stainless steel gills<sup>1)</sup> for the side panels express strength and dynamism – and accentuate the individual character of your Antos.



**Side window wind deflectors.** The aerodynamically optimised tinted or clear side window deflector set for the driver's or co-driver's side protects against the airflow when driving with the windows open.

<sup>1)</sup> For Antos only.



**Please note:** Changes may have been made to the product since going to press (04.11.2014). The manufacturer reserves the right to make changes to the design, form, colour and specification during the delivery period, provided these changes, while taking into account the interests of the vendor, can be deemed reasonable with respect to the purchaser. Where the vendor or the manufacturer uses symbols or numbers to describe an order or the subject of an order, no rights may be derived solely from these. The illustrations and texts may include accessories and optional extras which do not form part of the standard specification. Colours may differ slightly from those shown in the brochure, owing to the limitations of the printing process. This brochure may also contain models and services which are not available in certain countries.

This brochure is distributed internationally. It provides a general indication of the range of models, features, special equipment and/or colours available in various countries. Some of the models, features, special equipment and/or colours may not be available in your country, or may only be available in a different specification. Additionally some models, features, special equipment and/or colours may only be available in combination with others. For current and more specific information relating to the range of models, features, special equipment and/or colours available in your country, and their pricing, you should contact your nearest authorised Mercedes-Benz truck Dealer.

[www.mptrucks.co.uk](http://www.mptrucks.co.uk)